

UNAUTHORIZED USE OF THIS DRAWING IS STRICTLY PROHIBITED

DAR	REV	DESCRIPTION	APPVD	DATE
1074	A	INITIAL RELEASE	TJD	3-06
1101	B	CHANGE AMP BAL FROM 0.65 TO 0.75	TJD	4-06
1123	C	ADD GROUND WRAPS	TJD	5-06
1283	D	CHANGE POWER FROM 200W TO 150W	TJD	4-07
1453	E	REVISE SPECIFICATIONS	DG	6-08
3744	F	SEE DAR	DG	6-12
4673	G	SEE DAR	DG	11-13
5325	H	SEE DAR	DG	1-15

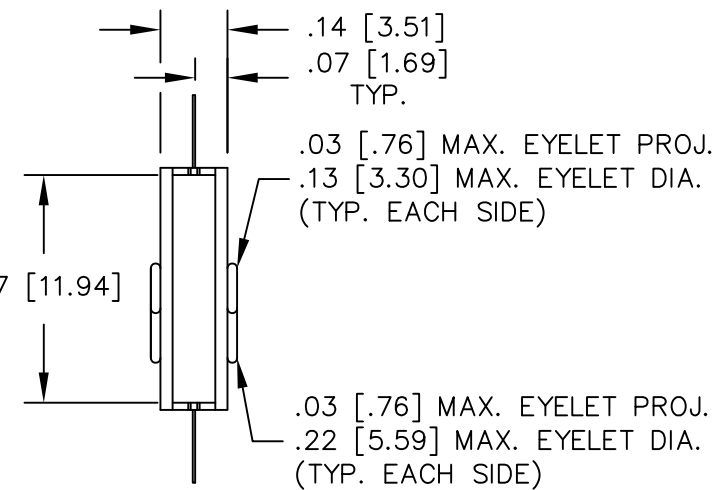
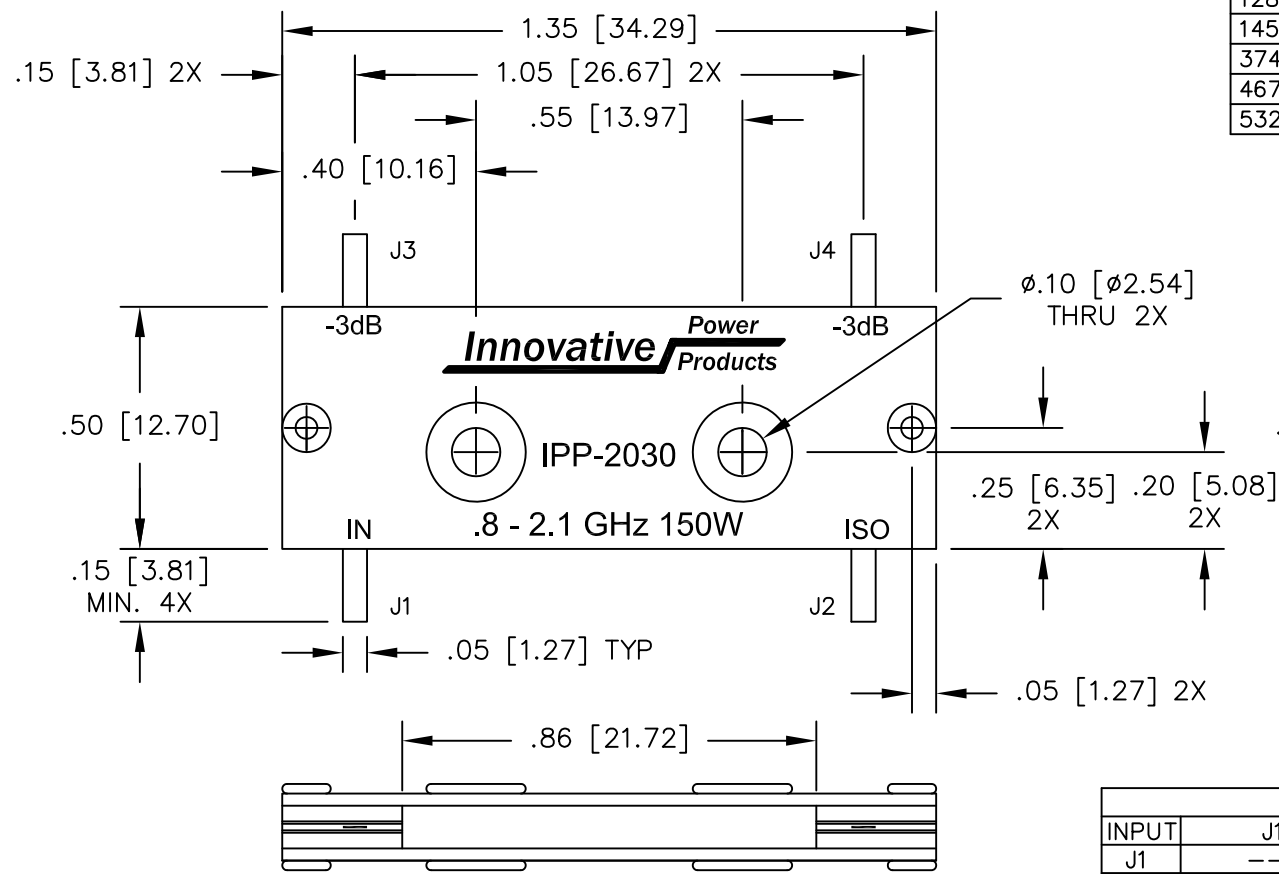

ELECTRICAL SPECIFICATIONS

FREQUENCY:	.8 - 2.1 GHz.
INSERTION LOSS:	< 0.30 dB
VSWR:	< 1.25:1
ISOLATION:	> 18 dB
AMPLITUDE BALANCE:	±0.75 dB
PHASE BALANCE:	±5°
POWER:	150 WATT
TEMPERATURE:	-55°C TO 85°C

- NOTES:**
- LEAD MATERIAL: 99.99% PURE SILVER .005 [.127] THICK.
 - SEE 90° APPLICATION NOTE FOR FURTHER INFORMATION.
 - RoHS COMPLIANT.
 - DATA AND SPECIFICATIONS APPLY WHEN PART IS MOUNTED IN IPP TEST FIXTURE TF-1000. TEST FIXTURE CONFIGURATION/FOOTPRINT AVAILABLE ON REQUEST.

PORT CONFIGURATION				
INPUT	J1	J2	J3	J4
J1	---	ISOLATION	-3dB<0 DEG	-3dB<-90 DEG
J2	ISOLATION	---	-3dB<-90 DEG	-3dB<0 DEG
J3	-3dB<0 DEG	-3dB<-90 DEG	---	ISOLATION
J4	-3dB<-90 DEG	-3dB<0 DEG	ISOLATION	---

MATERIAL	DWN DG	DATE 11/05				
AL. ALLOY, 6061-T6	ENG TJD	DATE 11/05				
FINISH CHEM FILM CLEAR PER MIL-DTL-5541, TYPE 2, REV F, CLASS 3 ROHS COMPLIANT	MANUF TP	DATE 11/05				
TOLERANCE .xx ±.02 [.50] IN [MM] .xxx ±.005 [.127] ANG. ±1/2°	CAGE CODE: 437R2		TITLE OUTLINE, COUP., 90°, .8 - 2.1 GHz. 150W			
	SHEET 1	OF 1	SCALE 4:1	SIZE B	P/N IPP-2030	REV. H