



IGAP-820 / IGAP-820+

Industrial IEEE 802.11 ac/g/n wireless access point with 2x10/100/1000Base-T(X)

Features

- **High Speed Air Connectivity: WLAN interface support up to 1.3Gbps link speed**
- Highly Security Capability: WEP/WPA/WPA-PSK(TKIP,AES)/WPA2/WPA2-PSK(TKIP,AES)/802.1X Authentication supported
- Support **X-Roaming < 60 ms**
- Support **wireless load balance**
- Support MAC Filter
- Support Long Distance Air Connectivity
- Provide Digital Input and Digital Output
- Support AP/Client Mode
- Support Multiple-SSID to 4 SSID
- Switch Mode Supported: Daisy Chain support to reduce usage of switch ports
- Wireless connecting status monitoring
- Secured Management by HTTPS
- Event Warning by Syslog, Email, SNMP Trap, Relay and Beeper
- Rigid IP-30 housing design
- DIN-Rail and Wall-mount enabled



Introduction

IGAP-820 series is a reliable WLAN Access Point with 2 Ethernet Gigabit ports and IEEE 802.11 ac/g/n wireless module. It can be configured to operate in AP/Client mode. You are able to configure IGAP-820 / IGAP-820+ by WEB interface via LAN port or WLAN interface. IGAP-820 series provides dual Ethernet ports in switch mode, so that you can use Daisy Chain to reduce the usage of Ethernet switch ports. In addition, IGAP-820+ also provides P.D. feature on ETH2 port which is fully compliant with IEEE802.3af PoE P.D. specification. Therefore, IGAP-820 series is one of the best communication solutions for wireless applications on the industrial network.

Application

In practical operation of wireless access point, Windows utility (Open-Vision) is supported. This utility is very helpful for you to search and configure IP of access point on the industrial network.

In addition, the wireless access point support various kinds of operation modes include AP/ Client mode. You can build up the wireless network easily

DI/DO Definition

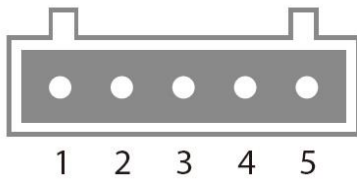

Digital Input Pin Definition

PIN	1	2	3	4	5
Function	DI1	DI2	DI3	DI4	COM

Digital Output Pin Definition

PIN	1	2	3	4	5
Function	DO1	DO2	DO3	DO4	GND

Dimension

Dimension (Unit =mm)

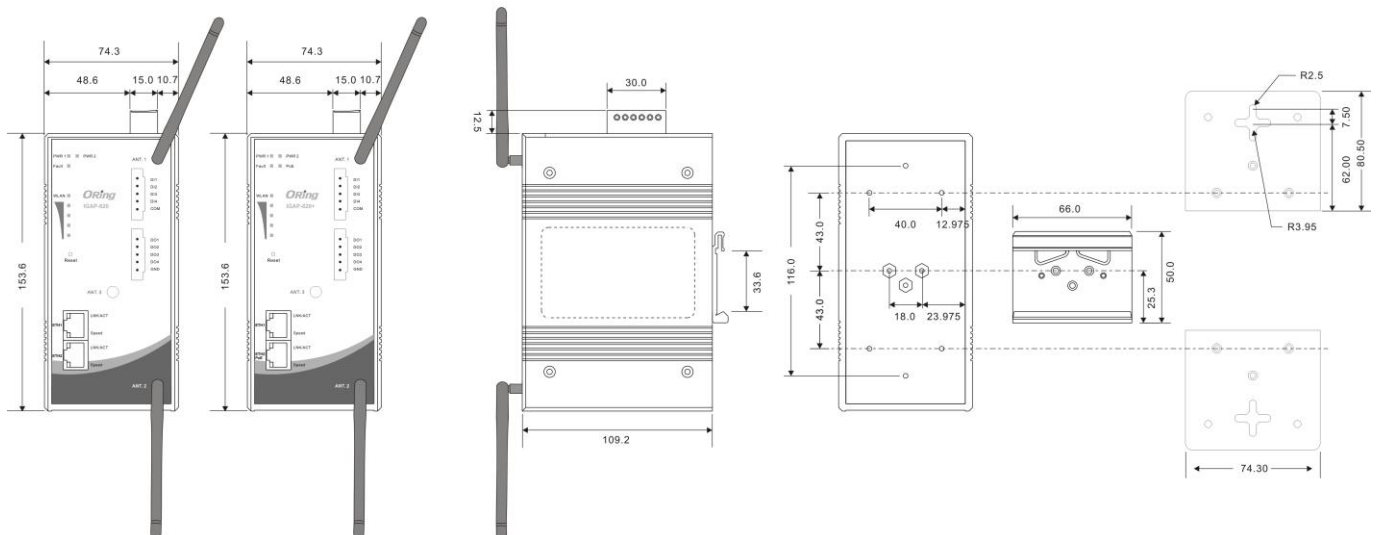

Specifications

ORing WLAN Access Point Model	IGAP-820	IGAP-820+
Physical Ports		
10/100/1000 Base-T(X) Ports in RJ45 Auto MDI/MDIX	2	
5-Pin Terminal Block	2(DI x 4 and DO x 4) : Dry Contact: On: short to GND, Off: open Wet Contact (DI to COM/GND): On: 0 to 3VDC, Off: 10 to 30VDC	
Antenna Connector	3	
PoE P.D Port	-	Present at ETH2 Fully compliant with IEEE 802.3af Power Device specification Over load & short circuit protection Isolation Voltage: 1000 VDC min. Isolation Resistance : 10 ⁸ ohms min
WLAN interface		
Operating Mode	AP/Client	
Antenna Connector	Reverse SMA Female	
Modulation	IEEE802.11a: OFDM IEEE802.11b: CCK/DQPSK/DBPSK IEEE802.11g: OFDM IEEE802.11n: BPSK, QPSK, 16-QAM, 64-QAM IEEE802.11ac: BPSK, QPSK, 16-QAM, 64-QAM, 256-QAM	
Frequency Band	America/FCC: 2.412~2.462 GHz 5.180~5.240 GHz & 5.745~5.825 GHz Europe CE/ETSI: 2.412~2.472 GHz 5.180~5.240 GHz	
Transmission Rate	802.11b: 11, 5.5, 2, 1 Mbps; 802.11g: 54, 48, 36, 24, 18, 12, 9, 6 Mbps 802.11n: up to 450Mbps 802.11ac : up to 1.3Gbps	
Transmit Power	802.11a: 15dBm ± 2dBm@54Mbps 802.11b: 18dBm ± 2dBm@11Mbps 802.11g: 15dBm ± 2dBm@54Mbps 802.11gn HT20: 13dBm ± 2dBm @MCS7 802.11gn HT40: 13dBm ± 2dBm @MCS7 802.11an HT20: 13dBm ± 2dBm @MCS7 802.11an HT40: 12dBm ± 2dBm @MCS7 802.11ac VHT80: 10dBm ± 2dBm @MCS9	
Receiver Sensitivity	802.11a : -65dBm ± 2dBm@54Mbps 802.11b : -76dBm ± 2dBm@11Mbps 802.11g : -65dBm ± 2dBm@54Mbps 802.11gn HT20:-64dBm ± 2dBm@MCS7 802.11gn HT40:-61dBm ± 2dBm@MCS7 802.11an HT20:-64dBm ± 2dBm@MCS7 802.11an HT40:-61dBm ± 2dBm@MCS7 802.11ac VHT80:-51dBm ± 2dBm@MCS9	
Encryption Security	WEP: (64-bit ,128-bit key) WPA/WPA2 PSK :TKIP and AES encryption (802.11i) 802.1X/RADIUS Authentication supported	
Wireless Security	SSID broadcast disable and enable	
Protocol Support		
Protocol	ARP,BOOTP, DHCP, DNS, HTTP, IP, ICMP, SNTP, TCP, UDP, RADIUS, SNMP, STP, RSTP	
LED Indicators		
Power Indicator	3 x LEDs, PWR1(2)(PoE)/Ready: Red On : Power is on and booting up Green On : Power is on and functioning Normal	

10/100/1000Base-T(X) RJ45 Port Indicator	2 x LEDs, Green for port Link/Act at 1000Mbps Amber for port Link/Act at 100Mbps.	
WLAN LED	Green Solid On: RF on, Blink: data transmitting Green for WLAN Strength: 1<25%, 2<50%, 3<75%, 4<100%	
Fault	1 x LED, Red for Ethernet link down or power down indicator	
Fault contact		
Relay	Relay output to carry capacity of 1A at 24VDC	
Power		
Redundant Input Power	Dual DC inputs. 12~48VDC on 6-pin terminal block	
Power Consumption (Typ.)	7.5W	8.5W
Overload Current Protection	Present	
Reverse Polarity Protection	Present on terminal block	
Physical Characteristic		
Enclosure	IP-30	
Dimension (W x D x H)	74.3(W) x 109.2(D) x 153.6(H) mm (2.93 x 4.3 x 6.05 inch.)	
Weight (g)	1150	1155
Environmental		
Storage Temperature	-40 to 85°C (-40 to 185°F)	
Operating Temperature	-25 to 70°C (-13 to 158°F)	
Operating Humidity	5% to 95% Non-condensing	
Regulatory Approvals		
EMI	FCC Part 15, CISPR (EN55022) class A	
EMS	EN61000-4-2 (ESD), EN61000-4-3 (RS), EN61000-4-4 (EFT), EN61000-4-5 (Surge), EN61000-4-6 (CS), EN61000-4-8, EN61000-4-11	
Shock	IEC60068-2-27	
Free Fall	IEC60068-2-32	
Vibration	IEC60068-2-6	
Safety	EN60950-1	
Warranty	5 years	

Ordering Information

IGAP-ABOC

Code Definition	Wireless Mode	10/100/1000Base-T(X) Port Number	PoE Identification
Option	- 1: 802.11 b/g - 2: 802.11 a - 3: 802.11 a/b/g - 4: 802.11 b/g/n - 5: 802.11 a/n - 6: 802.11 a/b/g/n - 8: 802.11 ac/g/n	- "2": 2 ports	- " +": PoE P.D. present at ETH2
Available Model	Model Name	Description	
	IGAP-820_US	Industrial IEEE 802.11 ac/g/n wireless access point with 2x10/100/1000 Base-T(X), US band	

IGAP-820_EU	Industrial IEEE 802.11 ac/g/n wireless access point with 2x10/100/1000 Base-T(X), EU band
IGAP-820+_US	Industrial IEEE 802.11 ac/g/n wireless access point with 2x10/100/1000 Base-T(X), 1-port PoE P.D, US band
IGAP-820+_EU	Industrial IEEE 802.11 ac/g/n wireless access point with 2x10/100/1000 Base-T(X), 1-port PoE P.D, EU band

Packing List

- **IGAP-820/IGAP-820+ x 1**
- **Antenna x 3**
- **6-Pin Terminal Block x 1**
- **CD x 1**
- **Din-Rail Kit x 1**
- **5-Pin Terminal Block x 2**
- **Quick Installation Guide x 1**
- **Wall-Mount Kit x 2**
- **Dust Cover x 2**

Optional Accessories

- **DR-45 series : 45 Watts power supply**
- **DR-120 series : 120 Watts power supply**
- **RF Antenna Base (Magnetic) series**
- **DR-75 series : 75 Watts power supply**
- **WLAN RF Antenna (Omni-directional) series**
- **RF Cable series**