

CONTACT CONFIGURATION  
TIMING (BBM) NON-SHORTING

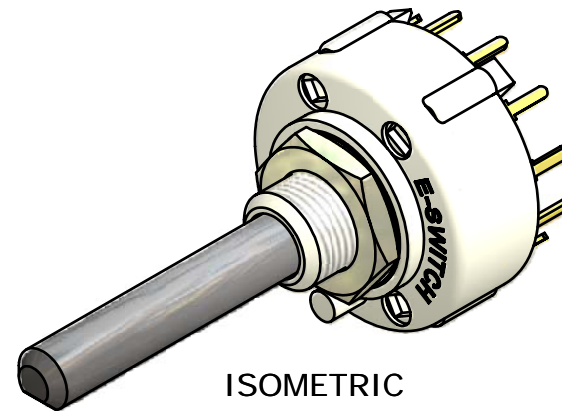

ISOMETRIC

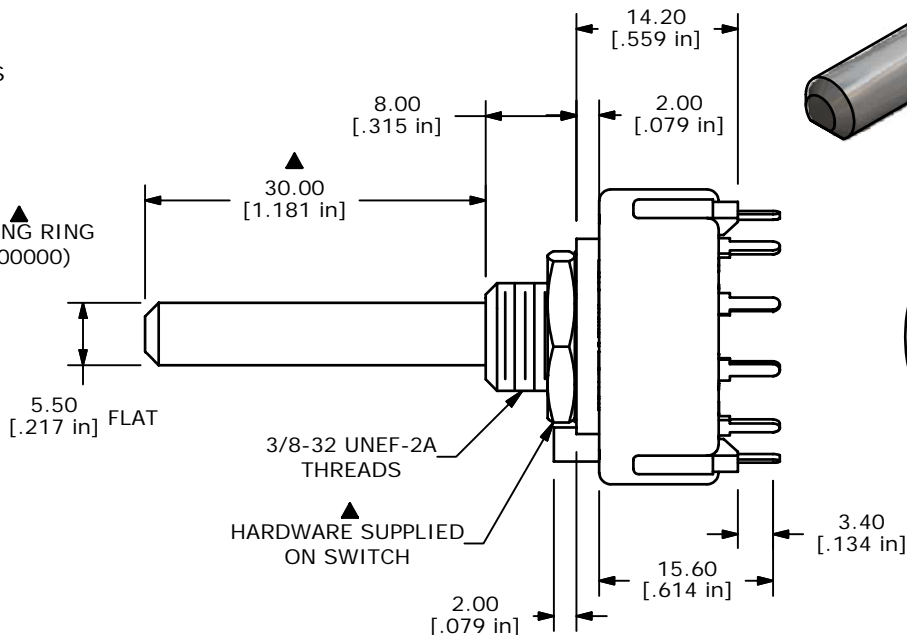
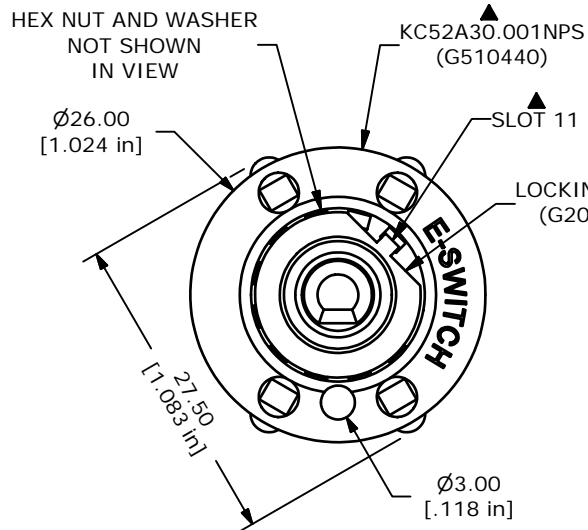
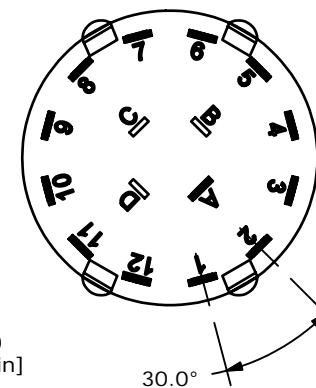

NOTE:

1. ALL DIMENSIONS IN MM[INCH].
2. GENERAL TOLERANCE: X.X=±0.4  
X.XX=±0.25
3. TERM. NOS. FOR REFERENCE ONLY.
- ▲4. CONTACT MATERIAL: SILVER
5. CONTACT RATING: 150MILLIAMP, 250VAC/DC  
350MILLIAMP, 110VAC/DC
6. CONTACT RATING (NON-SWITCHING) 5A
7. OPERATING FORCE 425±100CM/STANDARD
8. OPERATING TEMP: -30°C TO 85°C
- ▲9. CIRCUIT SP: 12 POSITION 30° INDEX.
10. DIELECTRIC STRENGTH: 1000V RMS MIN.@ SEA LEVEL.
- ▲11. HARDWARE SUPPLIED ON SWITCH:  
LOCKWASHER, HEXNUT, STOP RING (TAB IN POSITION 11)
12. ▲ DENOTES CRITICAL PARAMETER.
13. 2002/95/EC (ROHS) COMPLIANT



B	17333	FIXED NOTE 9, TOOK OUT NO STOP	5/25/07	TN
A	17189	RELEASED FOR PRODUCTION	4/17/07	TN
REV	PCR NO	DESCRIPTION	DATE	BY

TITLE KC52A30.001NPS W/LOCKRING				
SCALE	DATE	DR	DWG	REV
1.5:1	5/25/2007	TN	XG0005P	B

THE INFORMATION CONTAINED IN THIS DOCUMENT IS PROPRIETARY TO E-SWITCH AND IS NOT TO BE COPIED OR TRANSFERRED