



HIGH CONTRAST T-1 $\frac{3}{4}$ SOLID STATE LAMPS

HIGH EFFICIENCY RED (ORANGE) MV6151
YELLOW MV6351

HIGH EFFICIENCY GREEN MV6451
AlGaAs RED MV6951

PACKAGE DIMENSIONS

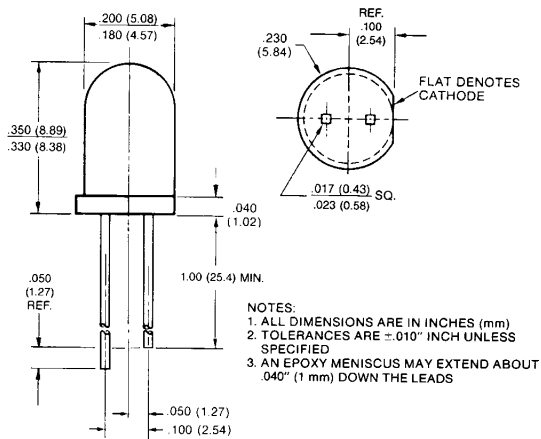

C1062F

DESCRIPTION

This White Diffused family of T-1 $\frac{3}{4}$ lamps gives maximum ON/OFF contrast in high ambient lighting levels. The family features Orange, AlGaAs Red (Dark Red), Yellow and High Efficiency Green as well as High Efficiency Red, which here is Orange. The family exhibits wide viewing angle intended for direct view.

FEATURES

- Excellent ON/OFF contrast
- Pale tint, diffused
- AlGaAs Red plus 3 bright colors: High Efficiency Red/Orange, Yellow and Green
- Alternative for popular MV6X53 family
- Snap-in grommet MP52 available as separate order item

PHYSICAL CHARACTERISTICS

TYPE	SOURCE COLOR	LENS COLOR	LENS EFFECT	APPLICATION
MV6151	High Efficiency Red	Pale Orange Diffused	Orange Diffused	Direct View
MV6351	Yellow	Pale Yellow Diffused	Yellow Diffused	Direct View
MV6451	High Efficiency Green	Pale Green Diffused	Green Diffused	Direct View
MV6951	AlGaAs Red	Pale Pink Diffused	Red Diffused	Direct View



HIGH CONTRAST T-1 3/4 SOLID STATE LAMPS

ELECTRO-OPTICAL CHARACTERISTICS ($T_A=25^\circ\text{C}$ Unless Otherwise Specified)									
PARAMETER		SYMBOL	MV6151	MV6351	MV6451	MV6951	UNITS	TEST COND.	NOTES
Luminous Intensity	min.	I_v	3.0	3.0	3.0	3.0	mcd	$I_f=20\text{ mA}$	
	typ.		12	12	12	12	mcd	$I_f=20\text{ mA}$	
Forward voltage	max.	V_f	3.0	3.0	3.0	3.0	V	$I_f=20\text{ mA}$	
	typ.		2.1	2.2	2.3	2.4	V	$I_f=20\text{ mA}$	
Peak wavelength	typ.	λ_p	635	585	565	650	nm	$I_f=20\text{ mA}$	
Reverse breakdown voltage	min.	V_{BR}	5	5	5	5	V	$I_f=100\mu\text{A}$	
Total viewing angle between half luminous points	typ.	$2\theta_{1/2}$	70	70	70	70	degrees	$I_f=20\text{ mA}$	

ABSOLUTE MAXIMUM RATINGS ($T_A=25^\circ\text{C}$ Unless Otherwise Specified)						
PARAMETER	YELLOW	HI EFF. RED RED	GREEN	UNITS	NOTES	
Power dissipation	85	120	120	mW	1	
Continuous forward current	20	35	30	mA		
Peak forward current (1 μs , 0.3% DF)	60	1000	90	mA		
Lead soldering time at 260 $^\circ\text{C}$	5	5	5	seconds	2	
Storage and operating temperatures	-55 $^\circ\text{C}$ to +100 $^\circ\text{C}$		-55 $^\circ\text{C}$ to +100 $^\circ\text{C}$			

NOTES
1. Derate linearly from 25 $^\circ\text{C}$ (MV6451 from 50 $^\circ\text{C}$) at 1.6 mW/ $^\circ\text{C}$.
2. From a point minimum 1/16 inch (1.6 mm) from the bottom of the lamp.

TYPICAL ELECTRO-OPTICAL CHARACTERISTIC CURVES
(25°C Free Air Temperature Unless Otherwise Specified)

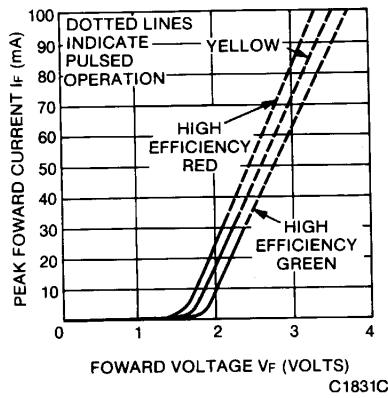

Fig. 1. Forward Current vs. Forward Voltage

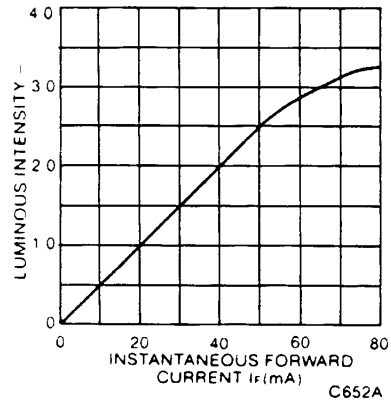

Fig. 2. Luminous Intensity vs. Forward Current

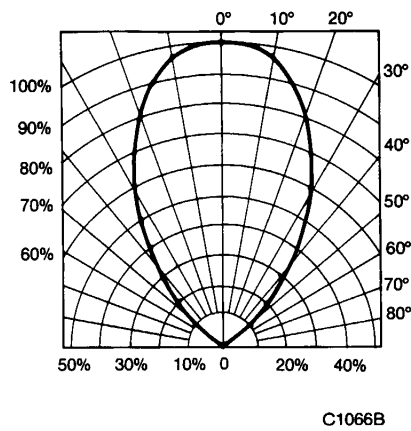

Fig. 3. Spatial Distribution

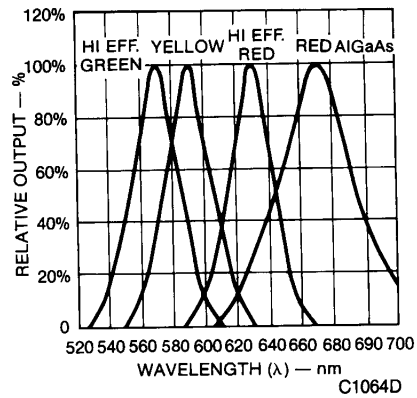

Fig. 4. Spectral Distribution