

NOM02A6-AR25G

200 DPI High-Speed Contact Image Sensor Module

Description

The NOM02A6-AR25G contact image sensor (CIS) module integrates a red LED light source, lens and image sensor in a compact housing. The module is designed for document scanning, mark reading, gaming and office automation equipment applications and is suitable for scanning documents up to 104 mm wide. An analog video output achieves a scanning rate of 167 $\mu\text{sec}/\text{line}$. The NOM02A6-AR25G module employs proprietary CMOS image sensing technology from ON Semiconductor to achieve high-speed performance and high sensitivity.

Features

- Light Source, Lens and Sensor are Integrated Into a Single Module
- 104 mm Scanning Width at 8 dots per mm Resolution
- 167 $\mu\text{sec}/\text{Line}$ Scanning Speed @ 5.0 MHz Pixel Rate
- Analog Video Output
- Supports A6 Paper Size at up to 74 Pages per Minute
- Red LED Light Source
- Wide Dynamic Range
- Compact 119.7 mm x 19.0 mm x 13.7 mm Module Housing
- Low Power
- Light Weight 1.1 oz Packaging
- These Devices are Pb-Free, Halogen Free/BFR Free and are RoHS Compliant

Applications

- Balloting, Gaming, Ticket and Check Scanner Machines
- Receipt Scanners
- Mark Readers
- Office Automation Equipment

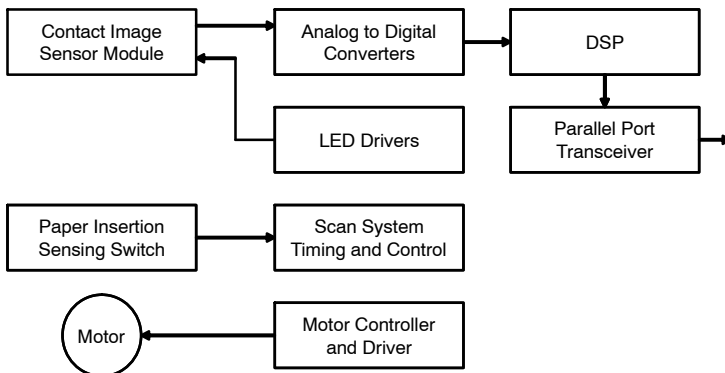

Figure 1. Typical Scanner Application



ON Semiconductor®

<http://onsemi.com>



IMAGE SENSOR MODULE A6
CASE MODAF

MARKING DIAGRAM

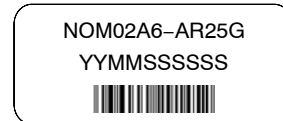

YY = Year
MM = Month
SSSSSS = Serial Number
G = Pb-Free Package

CONNECTOR PIN ASSIGNMENT

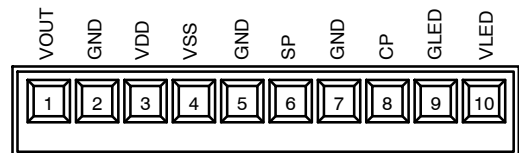

ORDERING INFORMATION

See detailed ordering and shipping information in the package dimensions section on page 2 of this data sheet.

NOM02A6-AR25G

Table 1. ORDERING INFORMATION

Part Number	Package	Shipping Configuration
NOM02A6-AR25G	(Pb-free)	100 per packing carton

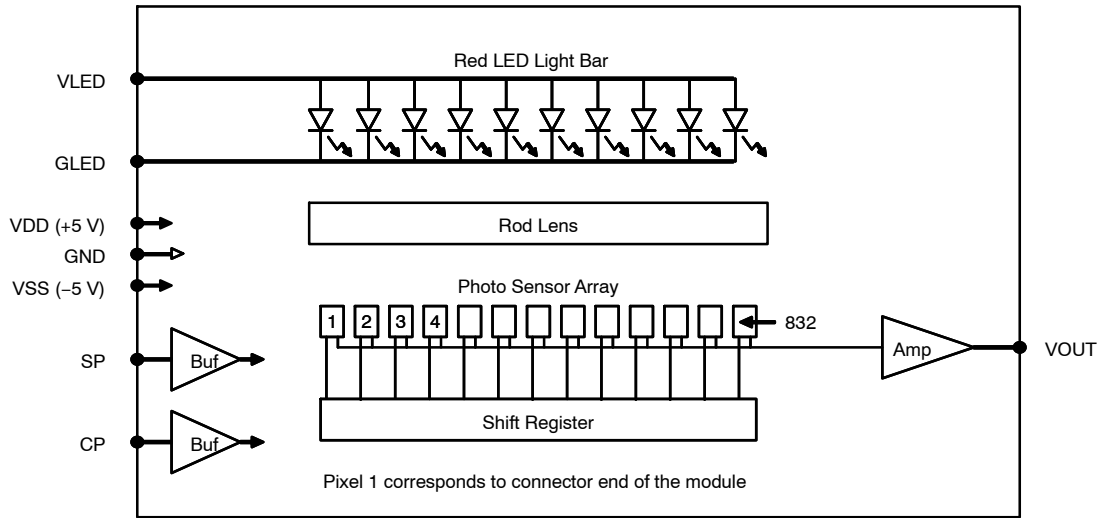

Figure 2. Simplified Block Diagram

Table 2. PIN FUNCTION DESCRIPTION

Pin	Pin Name	Description
1	VOUT	Analog Video Output
2	GND	Ground
3	VDD	+5 V power supply
4	VSS	-5 V to -12 V power supply
5	GND	Ground
6	SP	Shift register start pulse
7	GND	Ground
8	CP	Sampling clock pulse
9	GLED	Ground for the LED light source
10	VLED	Power supply for the LED light source

NOM02A6-AR25G

Table 3. ABSOLUTE MAXIMUM RATINGS

Parameter	Symbol	Value	Unit
Power supply voltage	V _{DD}	7	V
	V _{SS}	-15	V
	V _{LED}	6	V
Power supply current	I _{LED}	360	mA
Input voltage range for SP, CP	V _{in}	-0.5 to V _{DD} + 0.5	V
Storage Temperature	T _{STG}	-20 to 75	°C
Storage Humidity, Non-Condensing	H _{STG}	10 to 90	%
ESD Capability, Contact Discharge (Note 1)	ESD _{HBM}	± 2	kV

Stresses exceeding Maximum Ratings may damage the device. Maximum Ratings are stress ratings only. Functional operation above the Recommended Operating Conditions is not implied. Extended exposure to stresses above the Recommended Operating Conditions may affect device reliability.

1. This module assembly has been ESD tested to IEC61000-4-2 (HBM) Contact Discharge

Table 4. RECOMMENDED OPERATING RANGES (Unless otherwise specified, these specifications apply T_A = 25°C) (Note 2)

Parameter	Symbol	Min	Typ	Max	Unit
Power supply voltage (Note 3)	V _{DD}	4.5	5	5.5	V
	V _{SS}	-4.5	-5	-12	V
	V _{LED}		5	5.5	V
Power supply current	I _{DD}	20	30	40	mA
	I _{SS}		6	12	mA
	I _{LED}	45	100	150	mA
Low level input voltage for SP, CP	V _{IL}	0	0	0.6	V
High level input voltage for SP, CP	V _{IH}	V _{DD} - 1.0	V _{DD}	V _{DD} + 0.3	V
Line scanning rate (Note 4)	T _{int}	152	167		μs
Clock frequency (Note 5)	f	0.1	5.0	5.5	MHz
Clock period	t _o	182	200	100	ns
Clock pulse width (Note 6)	t _w	46	50	2500	ns
Clock pulse high duty cycle	DC _{CP}	20	25	60	%
Start pulse width (Note 6)	t _{wSP}	137	150	7500	ns
Start pulse setup time	t _{su}	20			ns
Start pulse hold time	t _h	20			ns
Prohibit crossing time (Note 7)	t _{prh}	20			ns
Clock to Video output propagation delay rising	t _{pcor}	60			ns
Clock to Video output propagation delay falling	t _{pcof}	70			ns
Operating Temperature	T _{op}	0		50	°C
Operating Humidity, Non-Condensing	H _{op}	10		60	%

2. Refer to Figure 3 for more information on AC characteristics
3. V_{LED} directly affects illumination intensity, which in conjunction with the LED timing and integration time, directly affects V_{OUT}.
4. T_{int} is the line scanning rate or integration time. T_{int} is determined by the interval between two start pulses. The clock is proportional to T_{int}.
5. Main clock frequency (f) corresponds to the video sampling frequency.
6. Min, Typ, Max specifications reflect operation at the corresponding Min, Typ, Max clock frequency.
7. Prohibit crossing time is to insure that two start pulses are not supplied in the same scan line time. SP may only be active high during one falling edge of CP for any given scan.

NOM02A6-AR25G

Table 5. PHYSICAL SPECIFICATIONS

Parameter	Symbol	Typ	Unit
Scan width	PD _w	104	mm
Number of Photo Detector Arrays	PDA _n	13	arrays
Number of Photo Detectors	PD _n	832	elements

Table 6. PHYSICAL CHARACTERISTICS

Parameter	Symbol	Min	Typ	Max	Unit
Pixel pitch	PD _{sp}		125		μm
Inter-array spacing	PDA _{sp}	150	180	210	μm
Inter-array vertical alignment	PDA _{vxp}	-40	0	40	μm
Red LED peak wavelength	λ _p	635		655	nm

Table 7. ELECTRO-OPTICAL CHARACTERISTICS TEST CONDITIONS

Parameter	Symbol	Value	Unit
Power supply voltage	V _{DD}	5.0	V
	V _{SS}	-5.0	V
	V _{LED}	5.0	V
Clock frequency	f	5.0	MHz
Clock pulse high duty cycle	DC _{CP}	25	%
Line scanning rate	T _{int}	167	μs
LED arrays pulsed time on (Note 8)	LED_Ton	26	ms
LED arrays pulsed time off (Note 8)	LED_Toff	356	ms
Operating Temperature	T _{op}	25	°C

8. Production tested with pulsing LEDs.

NOM02A6-AR25G

Table 8. ELECTRO-OPTICAL CHARACTERISTICS (Unless otherwise specified, these specifications were achieved with the test conditions defined in Table 7)

Parameter	Symbol	Min	Typ	Max	Unit
Bright analog output voltage (Note 9)	V_{pavg}	0.9	1.0	1.1	V
Bright output non-uniformity (Note 10)	U_p	-30		30	%
Bright output non-uniformity total (Note 11)	U_{ptotal}			60	%
Adjacent pixel non-uniformity (Note 12)	$U_{p adj}$			25	%
Dark output voltage (Note 13)	V_d	150		200	mV
Dark non-uniformity (Note 14)	U_d			75	mV
Modulation transfer function at 50 line pairs per in (lp/in) (Note 15)	MTF_{50}	40			%
Modulation transfer function at 100 line pairs per in (lp/in) (Notes 15, 16)	MTF_{100}	20			%

9. $V_{pavg} = \sum V_{p(n)}/832$, where
 V_p is the pixel amplitude value of V_{OUT} for a bright signal defined as a white document with LEDs turned on,
 n is the sequential pixel number in one scan line.
10. $U_p = [(V_{pmax} - V_{pavg})/V_{pavg}] \times 100\%$, or $[V_{pavg} - V_{pmin})/V_{pavg}] \times 100\%$, whichever is greater, where
 V_{pmax} is the maximum pixel voltage of any pixel at full bright
 V_{pmin} is the minimum pixel voltage of any pixel at full bright
11. $U_{ptotal} = [(V_{pmax} - V_{pmin})/V_{pavg}] \times 100\%$,
12. $U_{p adj} = \text{MAX} [| (V_{p(n)} - V_{p(n+1)}) / V_{p(n)} | \times 100\%$, where
 $U_{p adj}$ is the nonuniformity in percent between adjacent pixels for a bright background
13. V_d is the pixel amplitude value of V_{OUT} for a dark signal defined as a black document with LEDs turned off
14. $U_d = V_{dmax} - V_{dmin}$, where
 V_{dmax} is the maximum pixel voltage of any dark pixel with the LEDs turned off
 V_{dmin} is the minimum pixel voltage of any dark pixel with the LEDs turned off
15. $MTF = [(V_{max} - V_{min})/(V_{max} + V_{min})] \times 100\%$, where
 V_{max} is the maximum output voltage at the specified line pairs per inch (lp/in)
 V_{min} is the minimum output voltage at the specified lp/in
16. For information only.

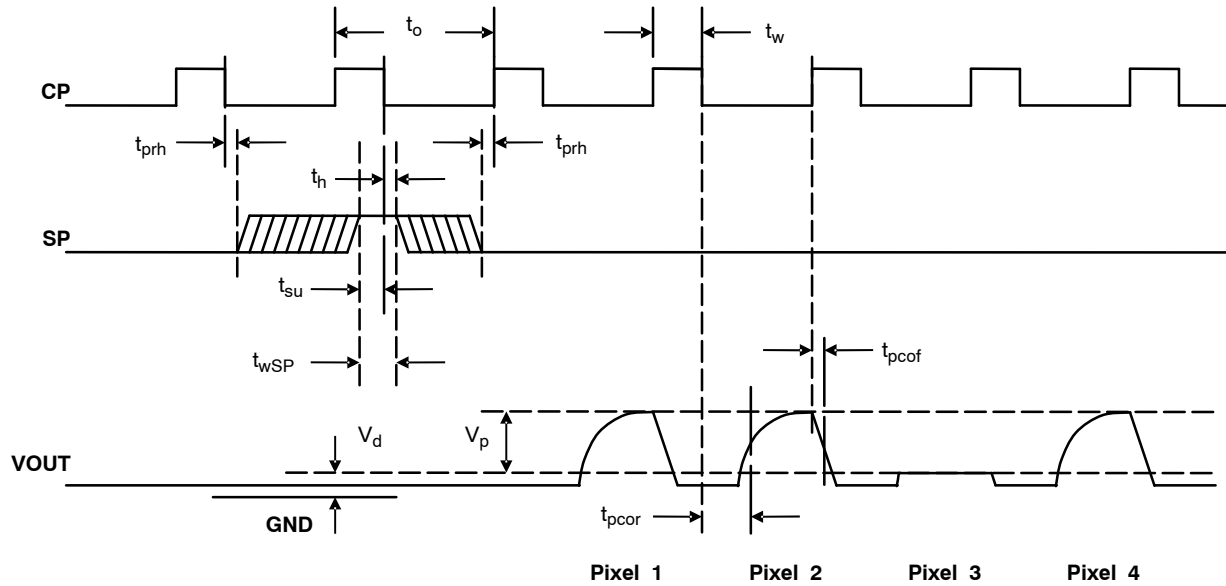

Figure 3. Timing Diagram

DESCRIPTION OF OPERATION

Functional Description

The NOM02A6-AR25G module consists of 13 contact image sensors, each with 64 pixel elements, that are cascaded to provide 832 photo-detectors with their associated multiplex switches and double-buffered digital shift register that controls its sequential readout. A buffer amplifies the video pixels from the image sensors and output the analog video signal of the module as shown in Figure 2. In operation, the sensors produce an analog image pixel signal (or video signal) proportional to the exposure on the corresponding picture elements on the document. The VOUT signal outputs 832 pixels for each scan line. The first bit shifted out from VOUT during each scan represents the first pixel on the connector end of the module.

A pictorial of the NOM02A6-AR25G cross section view is shown in Figure 4. Mounted in the module is a one-to-one graded-index micro lens array that focuses the scanned document image onto the sensing plane. Illumination is accomplished by means of an integrated LED light source. An internal reflector helps illuminate the document more completely, eliminating shadows caused by wrinkles in the paper. All components are housed in a small plastic housing, which has a glass cover. The top surface of the glass acts as the focal point for the object being scanned and protects the imaging array, micro lens assembly and LED light source from dust.

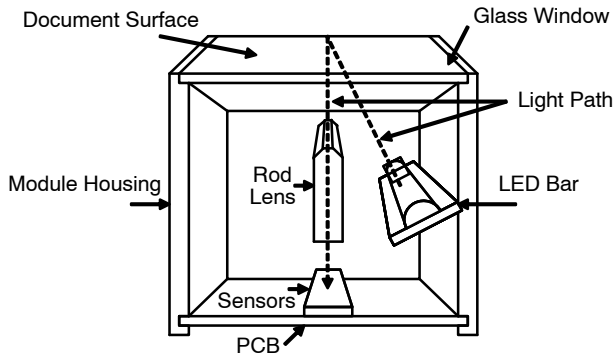

Figure 4. Module Cross Section View

Connector Pin Out Description

Connections to the module are via a 2.4x14.50mm 10-pin connector (ECE part number EBW-PK23-P010L2-3Z) located at one end of the module as shown in the package drawing on page 8. The location of pin number 1 is indicated on the package drawing.

Scanner Applications

A typical use of the NOM02A6-AR25G module in scanner applications is shown in Figure 6. The document to be digitized is fed into the scanner where a sensor detects its presence. The scanner then operates the motor to move the paper under the contact image sensor module. The module illuminates the paper with internal LEDs and the image sensor pixel array detects the amount of reflected light and simultaneously measures a full line of pixels which are sampled and transferred to a FIFO for storage and conversion to a parallel output format. Once the pixel line is

processed, the motor advances the paper and the next scan line is captured.

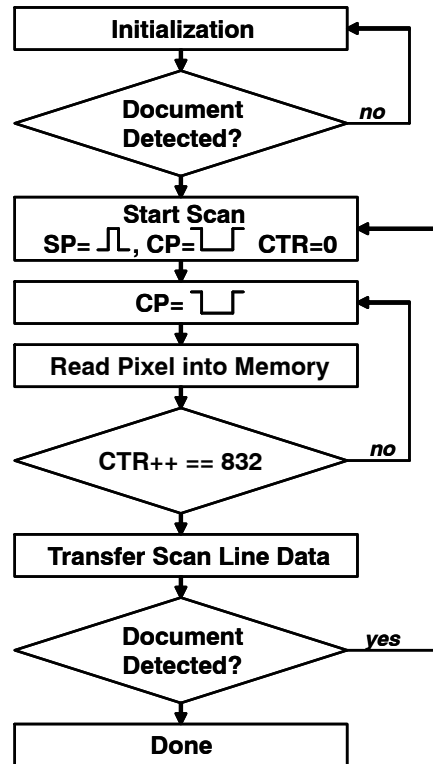

Figure 5. Typical Scanner Algorithm

Figure 5 outlines the basic steps in the scanner control sequence. First the circuits are initialized and the scanner waits for a document to be detected, usually by a paper sensing switch. Then a start pulse and clock pulse are supplied to capture a line image. At the next clock pulse the first pixel value appears on the output. The pixel can be stored in a local line buffer memory. Subsequent clocks cause the remaining pixels to be shifted out and stored in the line buffer. Once the complete line has been shifted out it can be transferred to the host application and the system advances the paper and the line scan process repeats until the paper sensing switch indicates the document has passed completely through the scanner.

Device Marking and Barcode Description

Each module is marked with a tag that contains the part number, a number combining the manufacturing date code and serial number and a barcode. The barcode presents the date code and serial number in Interleave 2 of 5 barcode format as follows

YYMMSSSSSS

where

YY is the year,
MM is the month, and
SSSSSS is the serial number.

Glass Lens Care

Precautions should be taken to avoid scratching or touching the glass lens. The glass lens may be cleaned with alcohol.

NOM02A6-AR25G

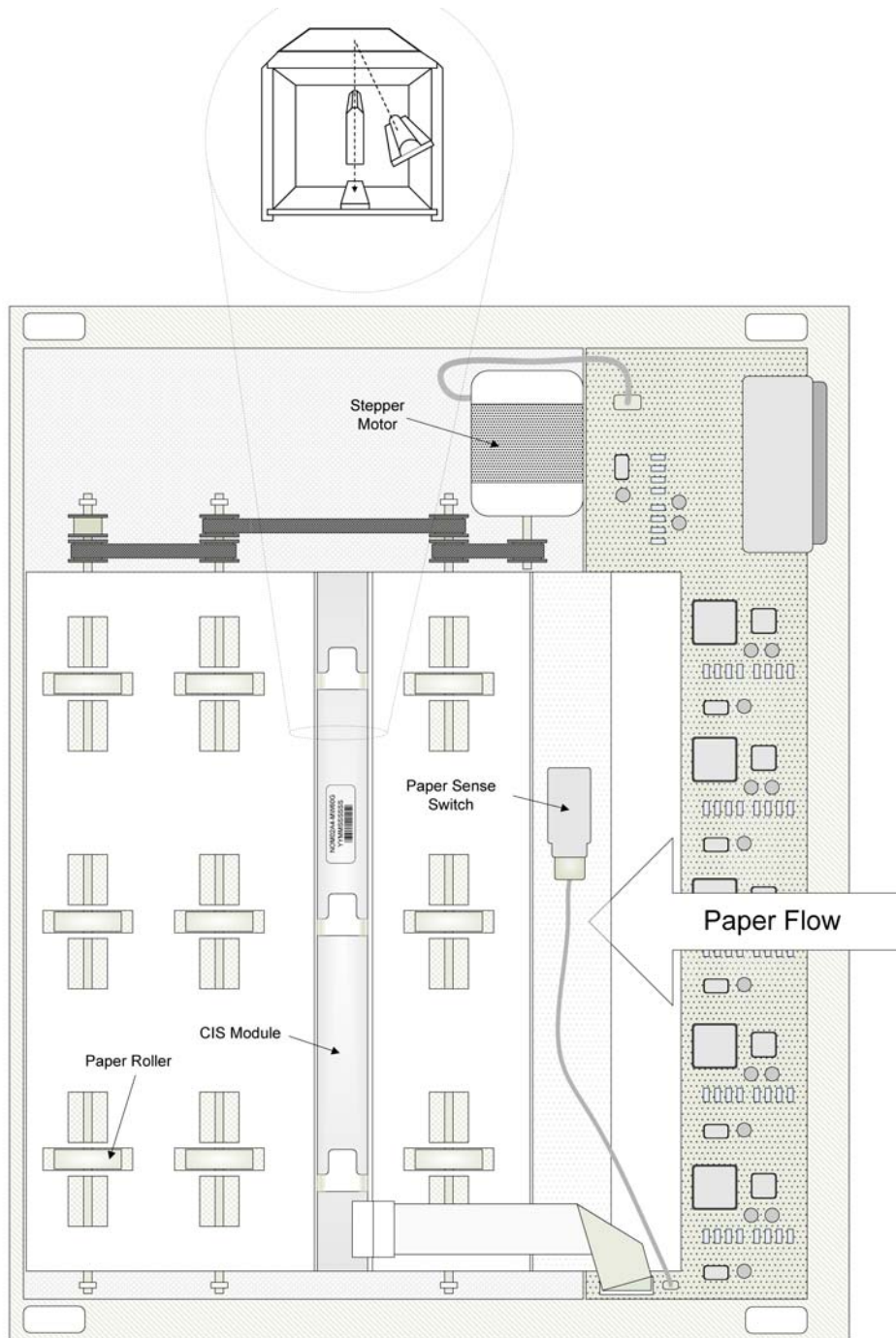
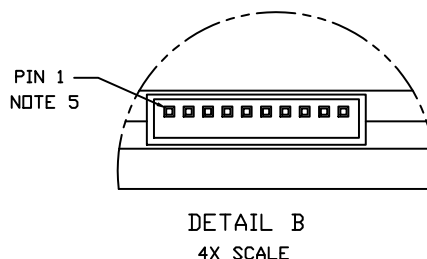
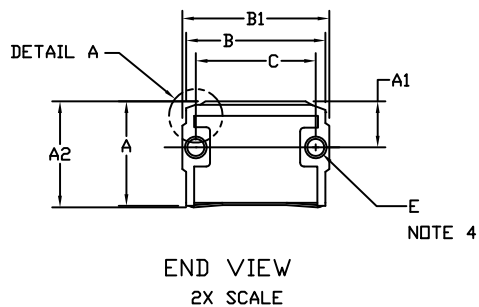
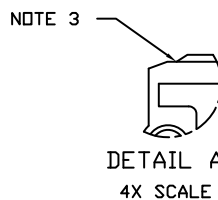
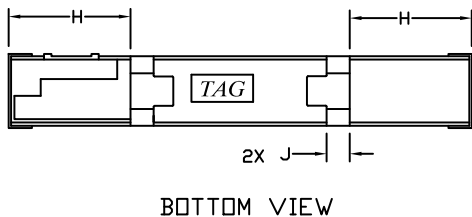
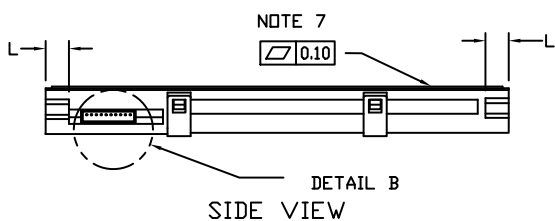
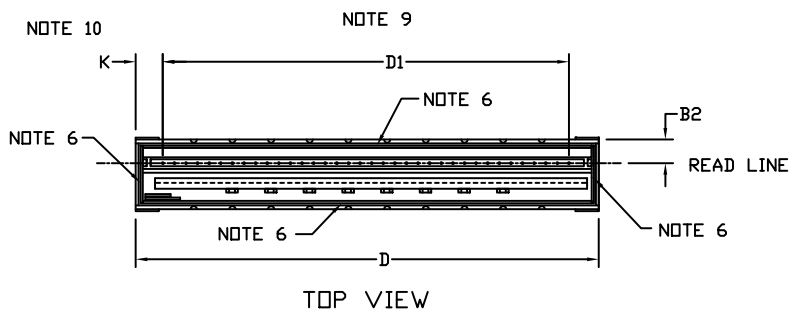

Figure 6. Typical Scanner Assembly

NOM02A6-AR25G

PACKAGE DIMENSIONS

IMAGE SENSOR MODULE A6 CASE MODAF ISSUE O



NOTES:

1. DIMENSIONING AND TOLERANCING PER ASME Y14.5M, 1994.
2. CONTROLLING DIMENSION: MILLIMETERS.
3. LEADING EDGE OF THE APPROACH ANGLE ON THE GLASS IS LOWER THAN THE TOP OF THE HOUSING.
4. BORE DEPTH IS 6.0 WITH A 0.2 LEAD-IN CHAMFER.
5. PIN HEADER, MODEL NUMBER EBW-PK23-P010L2-3Z, 1X10 PIN, PITCH 1.25.
6. GLASS IS GLUED ON ALL 4 SIDES.
7. GLASS THICKNESS IS 1.85.
8. USE M2.3 SELF TAPPING SCREWS FOR MOUNTING. TORQUE SCREWS BETWEEN 1.80 KGF-CM AND 2.00 KGF-CM.
9. DIMENSION D1 DENOTES THE SCAN LENGTH.
10. DIMENSION K DENOTES THE POSITION OF THE FIRST PIXEL.

DIM	MILLIMETERS	
	MIN	MAX
A	13.00	14.00
A1	6.70	7.70
A2	13.20	14.20
B	17.70	18.30
B1	18.70	19.30
B2	5.50	6.50
C	15.20	15.80
D	119.20	120.20
D1	104.00	REF
E	2.10	2.30
H	34.80	35.80
J	5.70	6.30
K	6.00	8.00
L	6.00	REF

NOM02A6-AR25G

PACKING DIMENSIONS

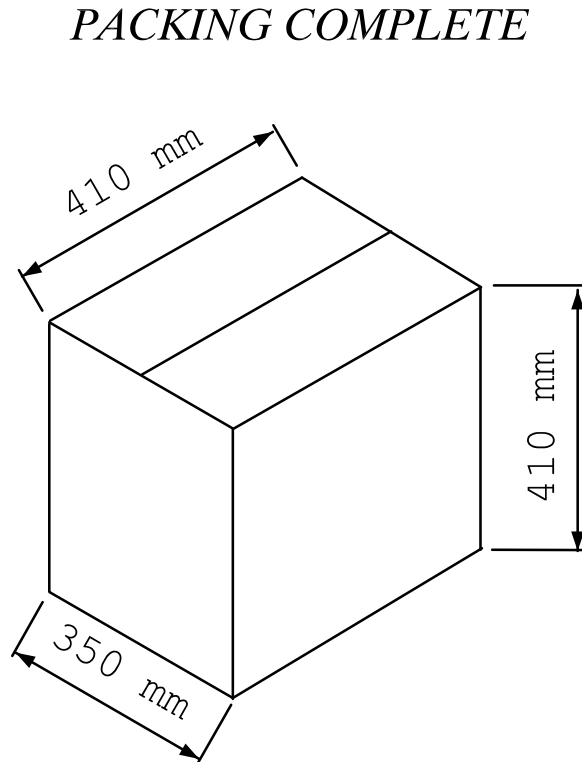
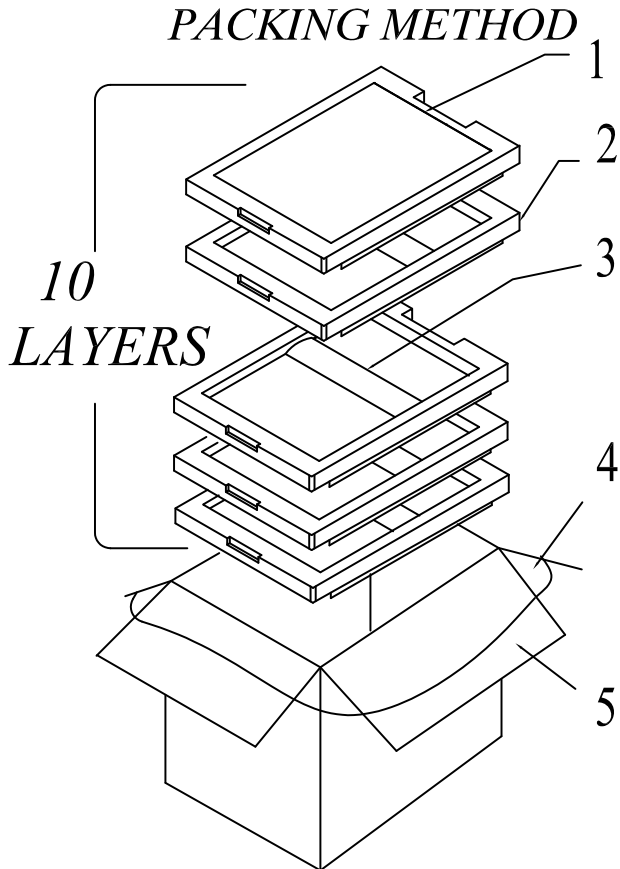

NO.	NAME	MATERIAL
1	Shockproof Pad	EPE
2	Packing Tray	POLYFOAM
3	Conduct Electricity Sheet	PE + CONDUCTIVE SHEET
4	Waterproof Bag	PE
5	Packing Box-Carton	KRAFT PAPER

ON Semiconductor and **OH** are registered trademarks of Semiconductor Components Industries, LLC (SCILLC). SCILLC owns the rights to a number of patents, trademarks, copyrights, trade secrets, and other intellectual property. A listing of SCILLC's product/patent coverage may be accessed at www.onsemi.com/site/pdf/Patent-Marking.pdf. SCILLC reserves the right to make changes without further notice to any products herein. SCILLC makes no warranty, representation or guarantee regarding the suitability of its products for any particular purpose, nor does SCILLC assume any liability arising out of the application or use of any product or circuit, and specifically disclaims any and all liability, including without limitation special, consequential or incidental damages. "Typical" parameters which may be provided in SCILLC data sheets and/or specifications can and do vary in different applications and actual performance may vary over time. All operating parameters, including "Typicals" must be validated for each customer application by customer's technical experts. SCILLC does not convey any license under its patent rights nor the rights of others. SCILLC products are not designed, intended, or authorized for use as components in systems intended for surgical implant into the body, or other applications intended to support or sustain life, or for any other application in which the failure of the SCILLC product could create a situation where personal injury or death may occur. Should Buyer purchase or use SCILLC products for any such unintended or unauthorized application, Buyer shall indemnify and hold SCILLC and its officers, employees, subsidiaries, affiliates, and distributors harmless against all claims, costs, damages, and expenses, and reasonable attorney fees arising out of, directly or indirectly, any claim of personal injury or death associated with such unintended or unauthorized use, even if such claim alleges that SCILLC was negligent regarding the design or manufacture of the part. SCILLC is an Equal Opportunity/Affirmative Action Employer. This literature is subject to all applicable copyright laws and is not for resale in any manner.

PUBLICATION ORDERING INFORMATION

LITERATURE FULFILLMENT:
 Literature Distribution Center for ON Semiconductor
 P.O. Box 5163, Denver, Colorado 80217 USA
Phone: 303-675-2175 or 800-344-3860 Toll Free USA/Canada
Fax: 303-675-2176 or 800-344-3867 Toll Free USA/Canada
Email: orderlit@onsemi.com

N. American Technical Support: 800-282-9855 Toll Free
 USA/Canada
Europe, Middle East and Africa Technical Support:
 Phone: 421 33 790 2910
Japan Customer Focus Center
 Phone: 81-3-5817-1050

ON Semiconductor Website: www.onsemi.com
Order Literature: <http://www.onsemi.com/orderlit>

For additional information, please contact your local Sales Representative