

TVP04A6V8-G Thru. TVP04A601-G

Breakdown Voltage: 6.8 to 600 Volts

Peak Pulse Power: 400 Watts

RoHS Device

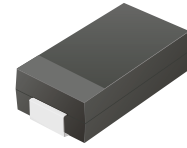

Features

- Glass passivated chip.
- Low leakage.
- 400W peak pulse power capability with a 10/1000 μ s waveform, repetitive rate (duty cycle): 0.01%.
- Uni and Bidirectional unit.
- Excellent clamping capability.
- Very fast response time.

Mechanical data

- Case: JEDEC DO-214AC, molded plastic.
- Epoxy: UL 94V-0 rate flame retardant.
- Terminals: Solderable per MIL-STD-750, method 2026.
- Polarity: Color band denotes cathode end.
- Mounting position: Any.
- Approx. weight: 0.069 grams

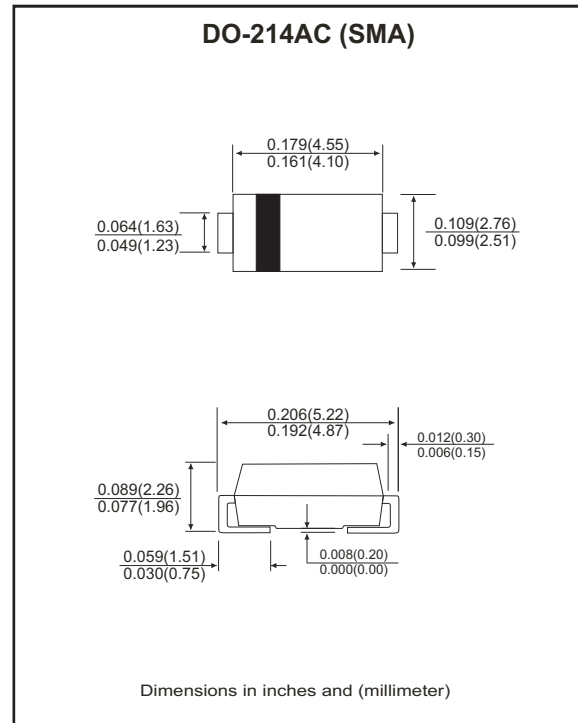

Maximum Ratings and Electrical Characteristics

Ratings at 25°C ambient temperature unless otherwise specified.
 Single phase, half wave, 60Hz, resistive or inductive load.
 For capacitive load, derate current by 20%.

Characteristics	Symbol	Value	Units
Peak power dissipation with a 10/1000 μ s waveform (Note 1)	P _{PP}	400	Watts
Peak pulse current with a 10/1000 μ s waveform (Note 1)	I _{PP}	See Next Table	A
Power dissipation on infinite heatsink at T _L =75°C	P _D	1.0	Watts
Peak forward surge current, 8.3ms single half sine-wave, uni-directional only (Note 2)	I _{FSM}	40	A
Maximum instantaneous forward voltage at 25.0A for uni-directional only (Note 3)	V _F	3.5/5.0	V
Operating junction temperature range	T _J	-55 to +150	°C
Storage temperature range	T _{STG}	-55 to +150	°C

Notes:

1. Non-repetitive current pulse per Fig.5 and derated above T_A=25°C per Fig.1
2. Measured on 8.3ms single half sine-wave or equivalent square wave, duty cycle = 4 pulses per minute maximum.
3. V_F<3.5V for devices of V_{BR}<200V and V_F<5.0V for devices of V_{BR}>201V

Rating and Characteristic Curves (TVP04A6V8-G Thru. TVP04A601-G)

Fig.1 - Pulse Derating Curve

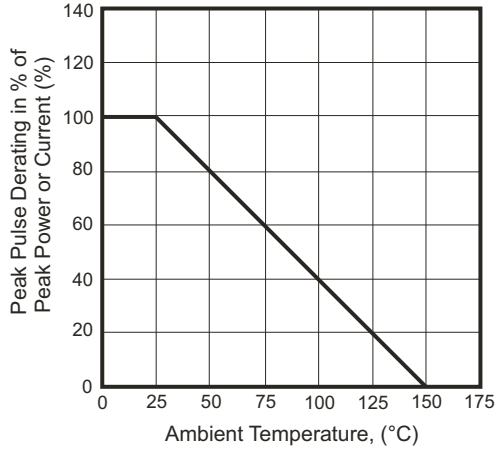

Fig.2 - Steady State Power Derating Curve

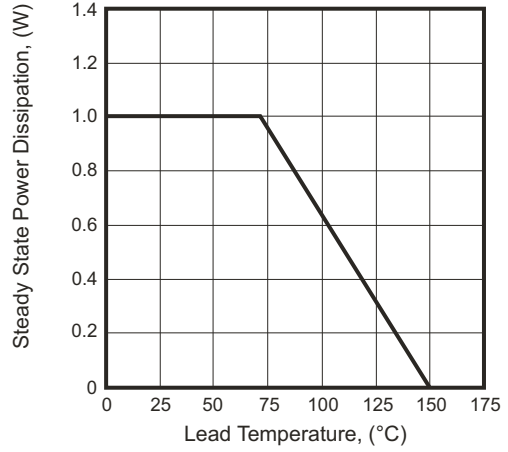

Fig.3 - Max. Non-repetitive Surge Current

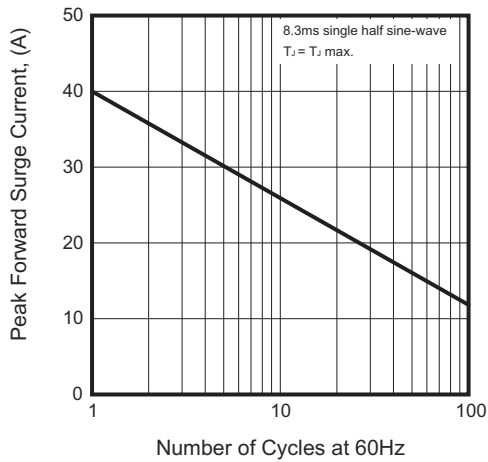

Fig.4 - Typical Junction Capacitance

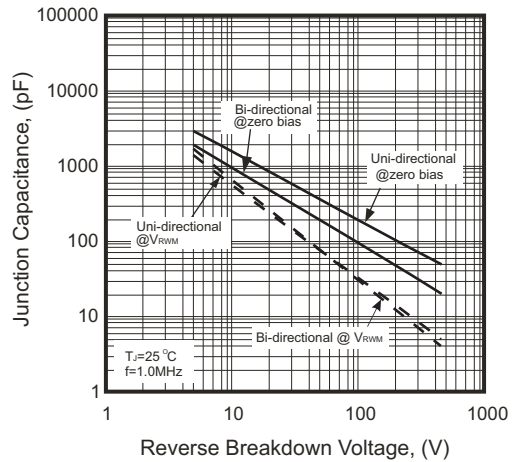

Fig.5 - Pulse Waveform

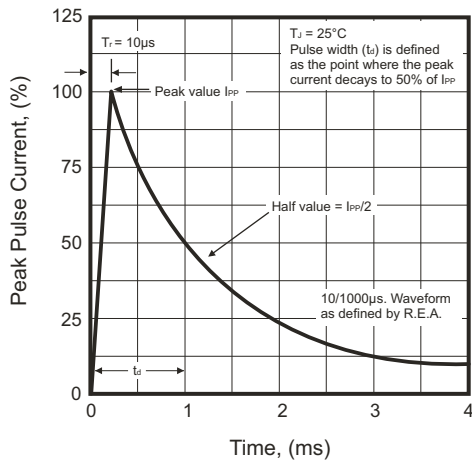
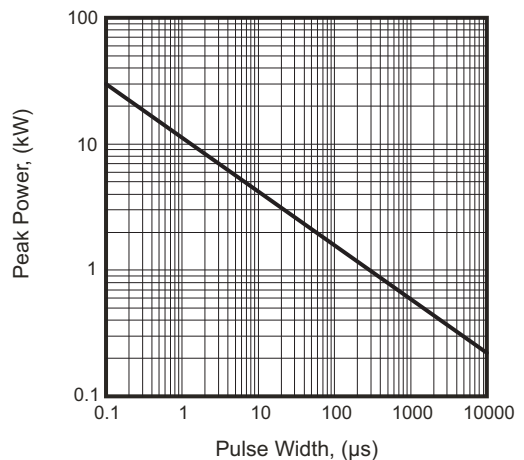

Fig.6 - Peak Pulse Power Rating Curve



SMD Transient Voltage Suppressor

Electrical Characteristics (TVP04A6V8-G Thru. TVP04A601-G)

Part No	Breakdown voltage V_{BR} @ I_T			Maximum Reverse Leakage @ V_{RWM} I_R (μ A)	Working Peak Reverse Voltage V_{RWM} (V)	Maximum Reverse Surge Current I_{PP} (A)	Maximum Clamping Voltage @ I_{PP} V_C (V)	Marking Code	
	V_{BR} Min. (V)	V_{BR} Max. (V)	I_T (mA)					UNI	BI
TVP04A6V8(C)A-G	6.46	7.14	10	1000	5.8	38.10	10.5	6V8A	6V8C
TVP04A7V5(C)A-G	7.13	7.88	10	500	6.4	35.40	11.3	7V5A	7V5C
TVP04A8V2(C)A-G	7.79	8.61	10	200	7.0	33.06	12.1	8V2A	8V2C
TVP04A9V1(C)A-G	8.65	9.56	1	50	7.8	29.85	13.4	9V1A	9V1C
TVP04A100(C)A-G	9.50	10.50	1	10	8.6	27.59	14.5	10A	10C
TVP04A110(C)A-G	10.45	11.55	1	5	9.4	25.64	15.6	11A	11C
TVP04A120(C)A-G	11.40	12.60	1	5	10.2	23.95	16.7	12A	12C
TVP04A130(C)A-G	12.35	13.65	1	5	11.1	21.98	18.2	13A	13C
TVP04A150(C)A-G	14.25	15.75	1	5	12.8	18.87	21.2	15A	15C
TVP04A160(C)A-G	15.20	16.80	1	5	13.6	17.78	22.5	16A	16C
TVP04A180(C)A-G	17.10	18.90	1	5	15.3	15.87	25.2	18A	18C
TVP04A200(C)A-G	19.00	21.00	1	5	17.1	14.44	27.7	20A	20C
TVP04A220(C)A-G	20.90	23.10	1	5	18.8	13.07	30.6	22A	22C
TVP04A240(C)A-G	22.80	25.20	1	5	20.5	12.05	33.2	24A	24C
TVP04A270(C)A-G	25.65	28.35	1	5	23.1	10.67	37.5	27A	27C
TVP04A300(C)A-G	28.50	31.50	1	5	25.6	9.66	41.4	30A	30C
TVP04A330(C)A-G	31.35	34.65	1	5	28.2	8.75	45.7	33A	33C
TVP04A360(C)A-G	34.20	37.80	1	5	30.8	8.02	49.9	36A	36C
TVP04A390(C)A-G	37.05	40.95	1	5	33.3	7.42	53.9	39A	39C
TVP04A430(C)A-G	40.85	45.15	1	5	36.8	6.75	59.3	43A	43C
TVP04A470(C)A-G	44.65	49.35	1	5	40.2	6.17	64.8	47A	47C
TVP04A510(C)A-G	48.45	53.55	1	5	43.6	5.71	70.1	51A	51C
TVP04A560(C)A-G	53.20	58.80	1	5	47.8	5.19	77.0	56A	56C
TVP04A620(C)A-G	58.90	65.10	1	5	53.0	4.71	85.0	62A	62C
TVP04A680(C)A-G	64.60	71.40	1	5	58.1	4.35	92.0	68A	68C
TVP04A750(C)A-G	71.25	78.75	1	5	64.1	3.88	103.0	75A	75C
TVP04A820(C)A-G	77.90	86.10	1	5	70.1	3.54	113.0	82A	82C
TVP04A910(C)A-G	86.45	95.55	1	5	77.8	3.20	125.0	91A	91C
TVP04A101(C)A-G	95.00	105.00	1	5	85.5	2.92	137.0	100A	100C
TVP04A111(C)A-G	104.50	115.50	1	5	94.0	2.63	152.0	110A	110C
TVP04A121(C)A-G	114.00	126.00	1	5	102.0	2.42	165.0	120A	120C
TVP04A131(C)A-G	123.50	136.50	1	5	111.0	2.23	179.0	130A	130C
TVP04A151(C)A-G	142.50	157.50	1	5	128.0	1.93	207.0	150A	150C
TVP04A161(C)A-G	152.00	168.00	1	5	136.0	1.83	219.0	160A	160C
TVP04A171(C)A-G	161.50	178.50	1	5	145.0	1.71	234.0	170A	170C
TVP04A181(C)A-G	171.00	189.00	1	5	154.0	1.63	246.0	180A	180C
TVP04A201(C)A-G	190.00	210.00	1	5	171.0	1.46	274.0	200A	200C
TVP04A221(C)A-G	209.00	131.00	1	5	185.0	1.22	328.0	220A	220C
TVP04A251(C)A-G	237.50	262.50	1	5	214.0	1.16	344.0	250A	250C
TVP04A301(C)A-G	285.00	315.00	1	5	256.0	0.97	414.0	300A	300C
TVP04A351(C)A-G	332.50	367.50	1	5	299.3	0.83	482.0	350A	350C
TVP04A381(C)A-G	361.00	399.00	1	5	324.9	0.76	524.4	380A	380C
TVP04A401(C)A-G	380.00	420.00	1	5	342.0	0.72	552.0	400A	400C
TVP04A441(C)A-G	418.00	462.00	1	5	376.2	0.66	607.2	440A	440C
TVP04A501(C)A-G	475.00	525.00	1	5	427.5	0.58	690.0	500A	500C
TVP04A521(C)A-G	494.00	546.00	1	5	444.6	0.56	717.6	520A	520C
TVP04A551(C)A-G	522.50	577.50	1	5	470.3	0.53	759.0	550A	550C
TVP04A601(C)A-G	570.00	630.00	1	5	513.0	0.48	828.0	600A	600C

Notes:

1. The available parts are A type only, the parts without A (V_{BR} is $\pm 10\%$) is not available.
2. Add suffix C or CA after part number to specify bi-directional devices.
3. For bi-directional devices having V_R of 10 volts and under, the I_R limit is double.

Reel Taping Specification

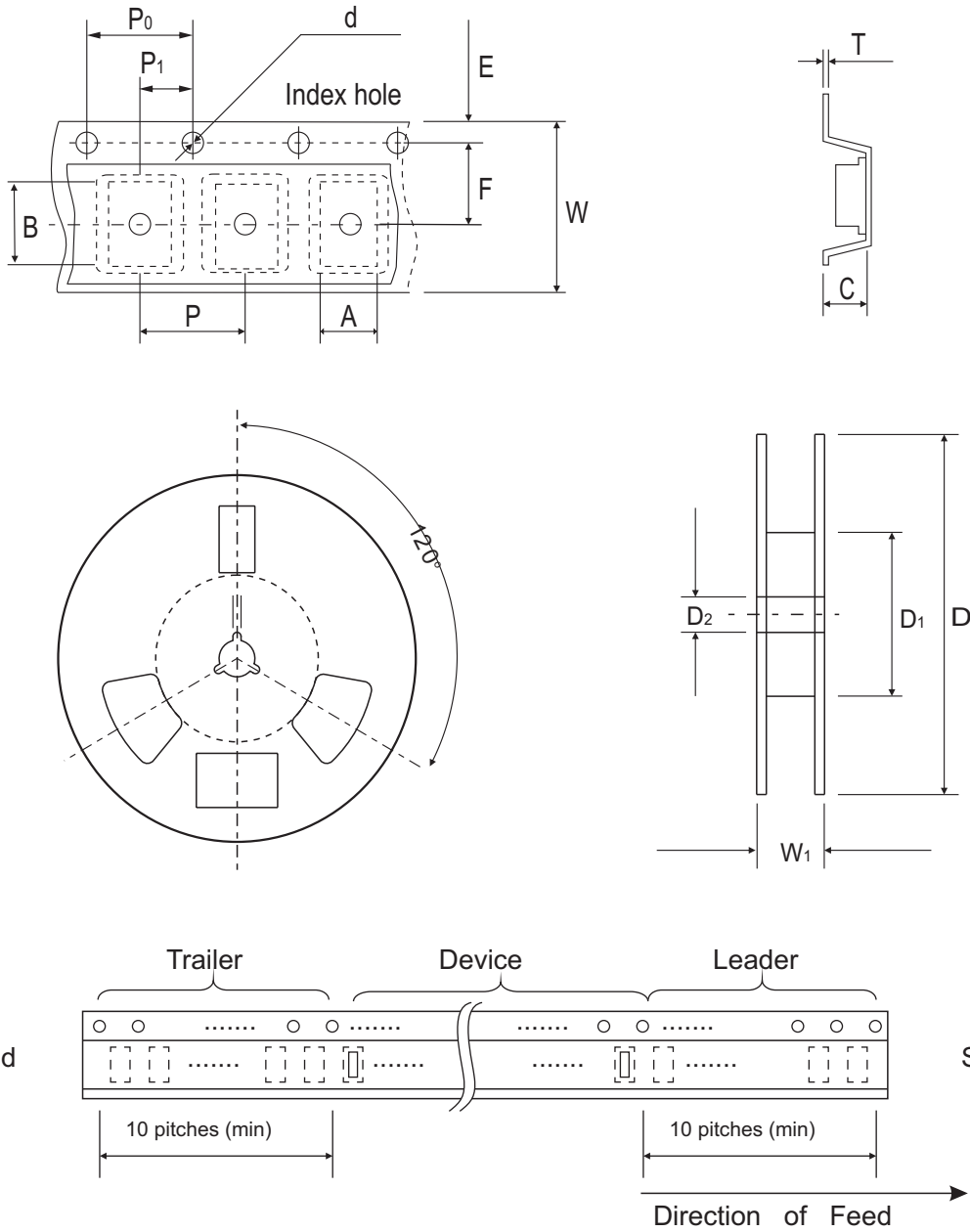

DO-214AC (SMA)	SYMBOL	A	B	C	d	D	D1	D2
	(mm)	2.79 ± 0.10	5.33 ± 0.10	4.50 (max)	1.55 ± 0.10	330.00	50.00 (min)	13.00 ± 0.20
	(inch)	0.110 ± 0.004	0.210 ± 0.004	0.177 (max)	0.061 ± 0.004	13.000	1.969 (min)	0.512 ± 0.008

DO-214AC (SMA)	SYMBOL	E	F	P	P0	P1	W	W1
	(mm)	1.75 ± 0.10	5.50 ± 0.05	4.00 ± 0.10	4.00 ± 0.10	2.00 ± 0.05	12.00 ± 0.30	18.40 (max)
	(inch)	0.069 ± 0.004	0.217 ± 0.002	0.157 ± 0.004	0.157 ± 0.004	0.079 ± 0.002	0.472 ± 0.012	0.724 (max)

Marking Code

1. C: COMCHIP
2. ○: Package

○	PKG
A	SMA
B	SMB
C	SMC

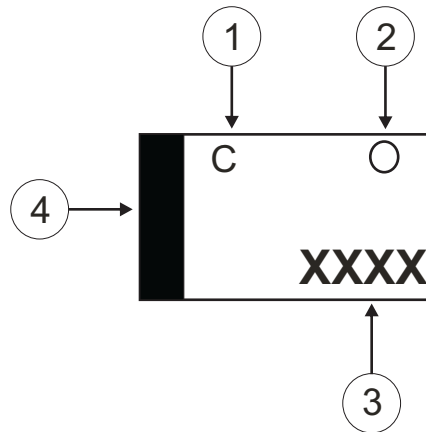

3. XXXX: Marking code (see Page.3)
4. █: Cathod Band

Suggested PAD Layout

SIZE	DO-214AC (SMA)	
	(mm)	(inch)
A	3.80	0.150
B	1.60	0.063
C	2.80	0.110
D	5.40	0.213
E	2.20	0.087

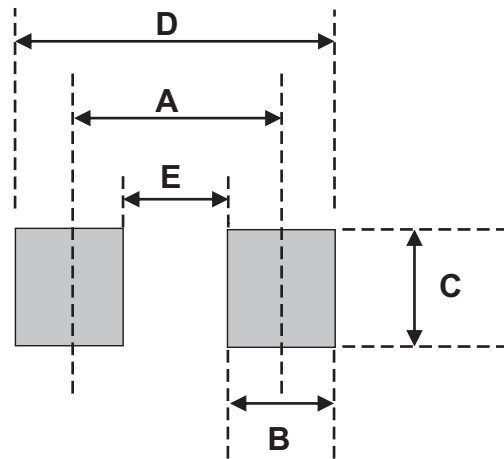

Standard Packaging

Case Type	REEL PACK	
	REEL (pcs)	Reel Size (inch)
DO-214AC (SMA)	5,000	13