

MX-COM, INC. MiXed Signal ICs

DATA BULLETIN

CMX469A

1200/2400/4800bps
MSK Modem

PRELIMINARY INFORMATION

Features

- Selectable Data Rates
1200/2400/4800 bps
- Full-Duplex MSK
- RX and TX Bandpass Filters
- Clock Recovery and Carrier Detect Capabilities
- Pin Selected Xtal/Clock Inputs
1.008MHz or 4.032MHz

Applications

- Radio and General Applications
- Data-Over-Radio
- PMR/Cellular Signaling
- Portable Data Terminals
- Narrowband Coax Data Channels
- Two Way Radio (MPT1327) Signaling
- Personal/Cordless Telephone

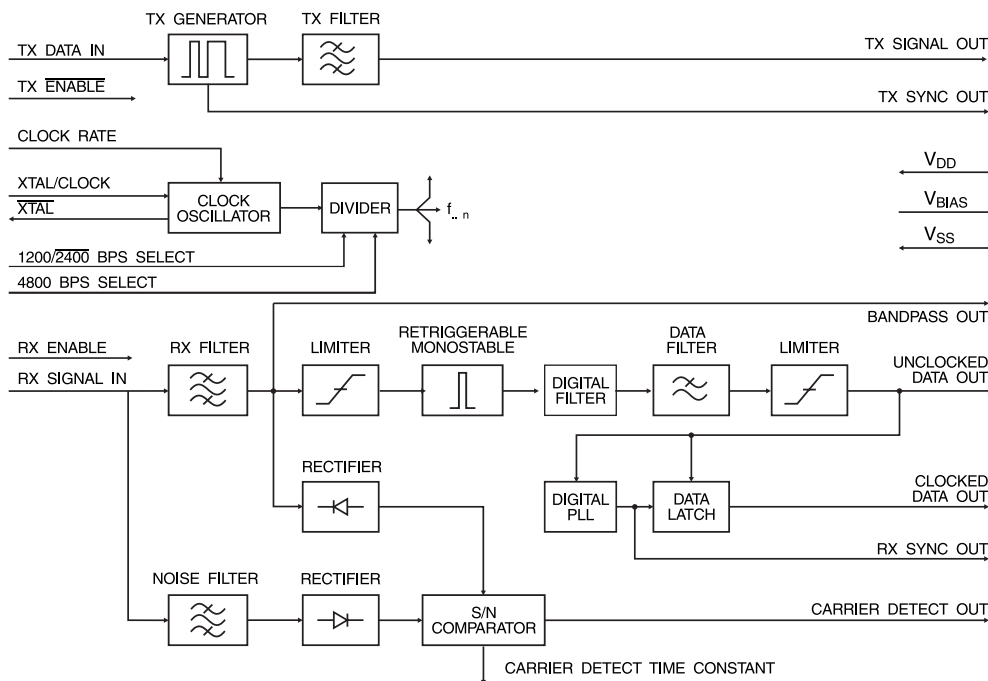

The CMX469A is a full-duplex pin-selectable 1200/2400/4800bps Minimum Shift Key (MSK) Modem for FM radio links. The mark and space frequencies are 1200/1800, 1200/2400, and 2400/4800Hz respectively. Tone frequencies are phase continuous; transitions occur at the zero crossing point. The use of a common Xtal oscillator with a choice of two clock frequencies (1.008MHz or 4.032MHz) provides data-rate, transmit frequencies, and RX/TX synchronization. The transmitter and receiver operate entirely independently including individual section powersave functions.

The CMX469A includes on-chip circuitry for Carrier Detect and RX Clock Recovery, both of which are made available at output pins. RX, TX and Carrier Detect circuits contain bandpass filters to provide high quality signals to their respective paths. The carrier detect time constant is set by an external capacitor, which may be selected to optimize performance in high-noise environments.

High sensitivity and good bit-error-rate performance can be achieved even under adverse signal conditions.

The CMX469A operates with a 3.0V to 5.5V supply and is available in the following packages: 24-pin TSSOP (CMX469AE2), 20-pin SOIC (CMX469AD3), and 22-pin PDIP (CMX469AP6).

Contents

Section	Page
1. Block Diagram	3
2. Signal List	4
3. External Components	6
4. General Description	7
4.1 Transmitter	7
4.2 Receiver	7
5. Application	8
5.1 Synchronous Modem Design Considerations	8
5.2 Test Set Up.....	9
5.3 Bit Error Rate.....	9
6. Performance Specifications	11
6.1 Electrical Specifications	11
6.1.1 Absolute Maximum Limits.....	11
6.1.2 Operating Limits	11
6.1.3 Operating Characteristics	12
6.1.4 Timing.....	14
6.2 Packages.....	17

MX-COM, Inc. reserves the right to change specifications at any time without notice.
--

1. Block Diagram

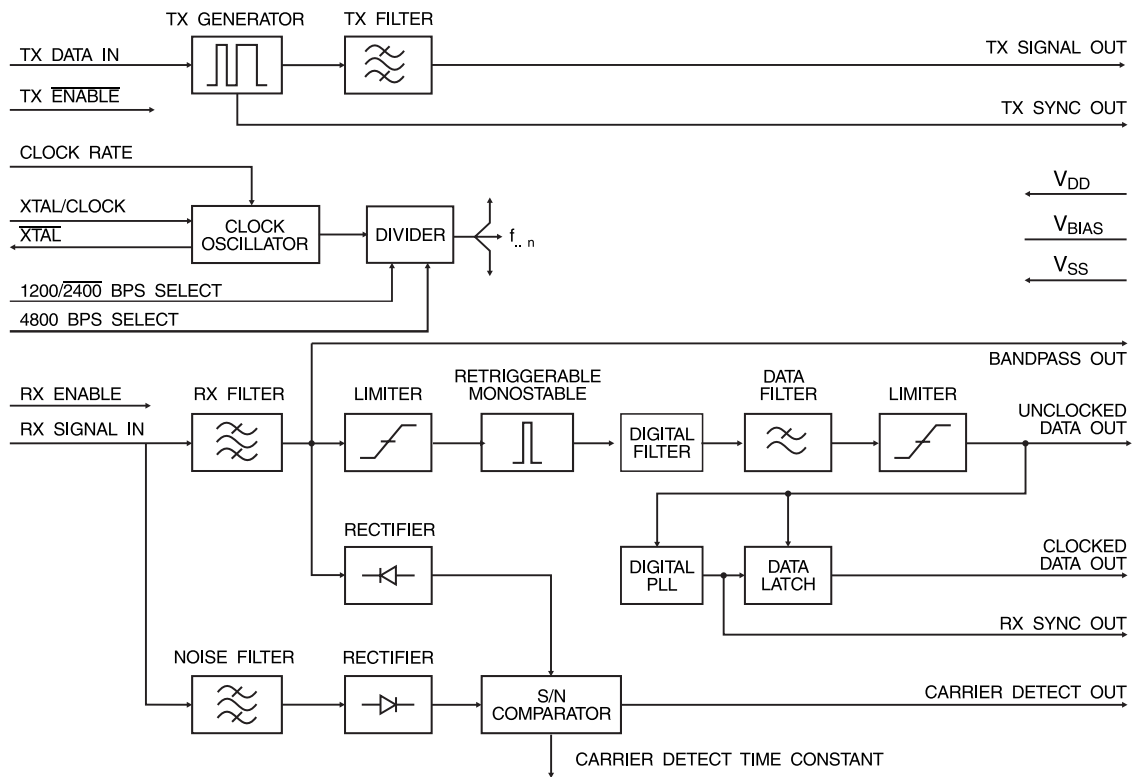

Figure 1: Block Diagram

2. Signal List

Pin No.			Signal		Description
E2	P6	D3	Name	Type	
1	1	1	Xtal/Clock	input	The input to the on-chip inverter, for use with either a 1.008MHz or a 4.032MHz Xtal or external clock. Clock frequency selection is by the "Clock Rate" input pin. The selection of this frequency will affect the operational Data Rate of this device. Refer to Table 3. As specified in the Performance Specifications, this input signal should be actively clocked (either driven from an external source or via an XTAL circuit).
2	2	2	$\overline{\text{XTAL}}$	output	Output of the on-chip inverter.
3	3	3	TX Sync Out	output	A squarewave, produced on-chip, to synchronize the input of logic data and transmission of the MSK signal. See Figure 8 and Section 4.1.
5	5	4	TX Signal Out	output	When the transmitter is enabled, this pin outputs the (140-step pseudo sinewave) MSK signal. See Figure 8. With the transmitter disabled, this output is set to a high-impedance state.
7	6	5	TX Data In	input	Serial logic data to be transmitted is input to this pin.
8	7	6	$\overline{\text{TX ENABLE}}$	input	A logic '0' will enable the transmitter. See Figure 8. A logic '1' at this input will put the transmitter into powersave while forcing "TX Sync Out" to a logic '1' and "TX Signal Out" to a high-impedance state. This pin is internally pulled to V_{DD} .
9	8	7	Bandpass Out	output	The output of the RX Bandpass Filter. This output impedance is typically 10k Ω and may require buffering prior to use.
10	9	8	RX Enable	input	The control of the RX function. The control of other outputs is provided in Table 2
11	10	9	V_{BIAS}	power	The output of the on-chip analog bias circuitry. Held internally at $V_{DD}/2$, this pin should be bypassed to V_{SS} by a capacitor (C2). See Figure 2 and RX Enable notes. This bias voltage is maintained under all powersave conditions.
12	11	10	V_{SS}	power	Negative supply (GND).
13	12	11	Unclocked Data Out	output	The recovered asynchronous serial data output from the receiver.
14	13	12	Clocked Data Out	output	The recovered synchronous serial data output from the receiver. Data is latched out by the recovered clock, available at the "RX Sync Out". See Figure 9 and Figure 11.
15	14	13	Carrier Detect	output	When an MSK signal is being received this output is a logic '1'.
16	15	14	RX Signal In	input	The MSK signal input for the receiver. This input should be coupled via a capacitor, C3.
18	17	15	RX Sync Out	output	A flywheel squarewave output. This clock will synchronize to incoming RX MSK data. See Figure 9 and Figure 11.

Pin No.			Signal		Description
E2	P6	D3	Name	Type	
19	16	16	1200/ $\overline{2400}$ BPS Select	input	A logic '1' on this pin selects the 1200bps option. Tone frequencies are: one cycle of 1200Hz represents a logic '1', one-and-a-half cycles of 1800Hz represents a logic '0'. A logic '0' on this pin selects the 2400bps option. Tone frequencies are: one-half cycle of 1200Hz represents a logic '1', one cycle of 2400Hz represents a logic '0'. This pin has an internal 1M Ω pull-up resistor. Operational Data Rate Configurations are illustrated in Table 3.
20	18	17	4800 BPS Select	input	A logic '1' on this pin combined with a logic '0' on the 1200/ $\overline{2400}$ BPS Select pin will select the 4800 option (1M Ω pulldown resistor). Tone frequencies are: one-half cycle of 2400Hz represents a logic '1', one full cycle of 4800Hz represents a logic '0'. This state can only be achieved using a 4.032MHz Xtal input. Operational Data Rate Configurations are illustrated in Table 3.
21	19	18	Clock Rate	input	A logic input to select and allow the use of either a 1.008MHz or 4.032MHz Xtal/clock. Logic '1' = 4.032MHz, logic '0' = 1.008MHz. This input has an internal pulldown resistor (1.008MHz).
22	20	19	Carrier Detect Time Constant	bi-directional	Part of the carrier detect integration function. The value of C4 connected to this pin will affect the carrier detect response time and therefore the noise performance.
24	22	20	V _{DD}	power	Positive supply. A single 2.7 to 5.0 volt supply is required. This pin should be bypassed to V _{SS} by a capacitor (C5).
4, 6, 17, 23	4, 21				No internal connection, do not use.

Table 1: Signal List

RX Enable	=	RX Function	Clock Data Output	Carrier Detect	Rx Sync Out
1	=	Enabled	Enabled	* Enabled	Enabled
0	=	Powersave	0	1 or 0	1 or 0

* After enabling the receiver, a time of at least 8 bit periods, plus 2ms, should be allowed for the Carrier Detect circuit to stabilize and provide a valid output.

Table 2: RX Enable Control Functions

XTAL/CLOCK Frequency	1.008MHz		4.032MHz		
Clock Rate pin	0	0	1	1	1
1200/ $\overline{2400}$ Select Pin	1	0	1	0	0
4800 Select Pin	0	0	0	0	1
Data Rate (bps)	1200	2400	1200	2400	4800

Table 3: Operational Data Rate Configuration

3. External Components

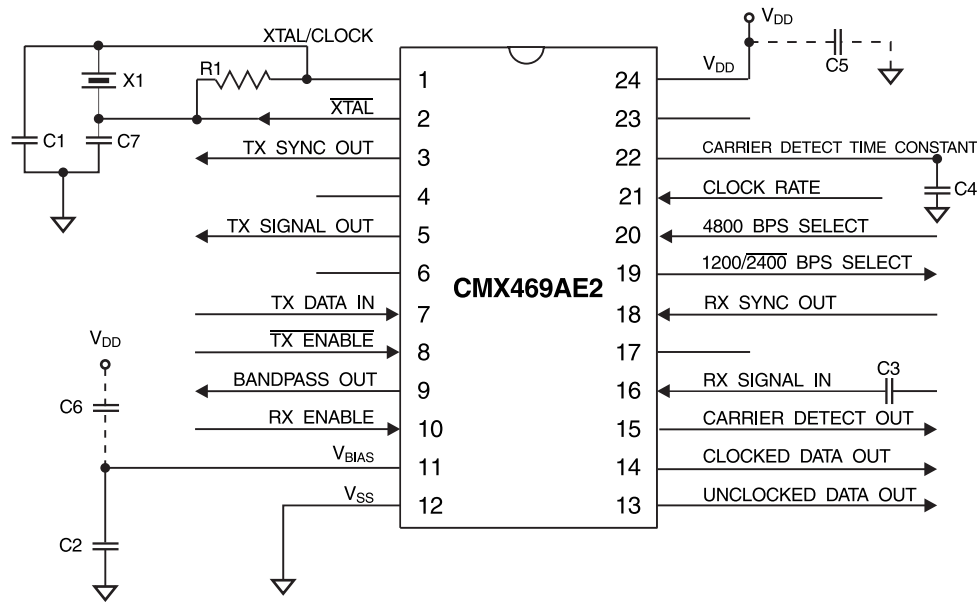

Figure 2: Recommended External Components for E2 package

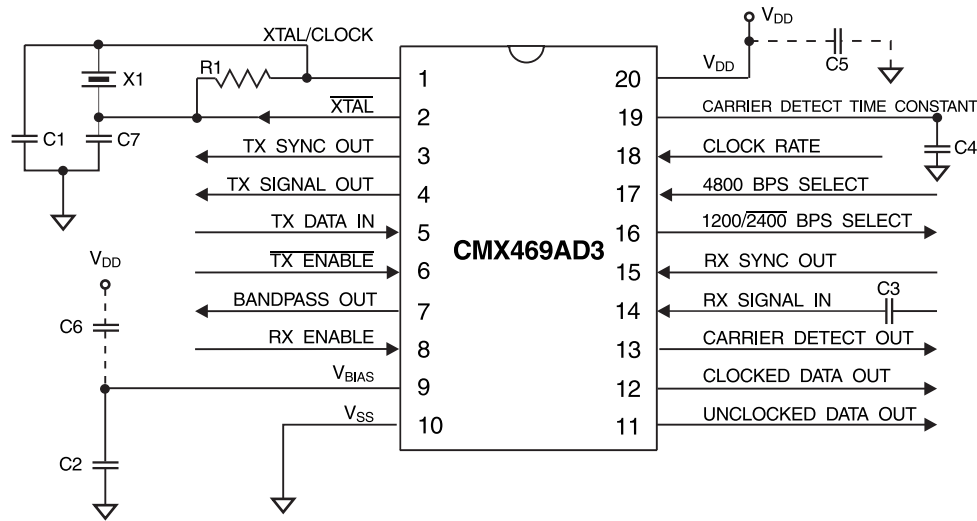

Figure 3: Recommended External Components for D3 package

Component	Notes	Value	Component	Notes	Value
R1		1.0MΩ	C5		1.0μF
C1		33.0pF	C6	1	1.0μF
C2	1	1.0μF	C7		33.0pF
C3		0.1μF	X1	3, 4, 5	1.008MHz or 4.032MHz
C4	2	0.1μF			

Table 4: Recommended External Components

Recommended External Component Notes:

1. V_{BIAS} may be bypassed to V_{SS} and V_{DD} using C2 and C6 when input signals are referenced to the V_{BIAS} pin. For input signals references to V_{SS} , bypass V_{BIAS} to V_{SS} using C2 only.
2. The performance of the Carrier Detect function will be affected by the nature of the noise spectrum in the received channel. The value of C4 determines the Carrier Detect time constant. A long time constant results in improved noise immunity but increased response time. C4 may be varied to trade-off response time for noise immunity.
3. A 4.032MHz Xtal/Clock is required for 4800 baud operation.
4. For best results, a crystal oscillator design should drive the clock inverter input with signal levels of at least 40% of V_{DD} , peak to peak. Tuning fork crystals generally cannot meet this requirement. To obtain crystal oscillator design assistance, consult your crystal manufacturer.

4. General Description

The CMX469A has two sections, apart from the Xtal oscillator circuit and clock dividers. These sections may be independently powersaved.

4.1 Transmitter

The transmitter is enabled by taking $\overline{\text{Tx Enable}}$ low. Serial data applied to Tx Data Input is sampled internally and an MSK sequence is generated. After filtering, this is output at Tx Signal Out and the transmit clock derived from this signal is output at Tx Sync Out.

The Tx Data must be valid at the time of the rising edge of the Tx Sync clock signal. Therefore, the optimum time to change Tx Data is on the falling edge of the Tx Sync clock.

4.2 Receiver

The receiver is enabled by taking Rx Enable high. The signal applied to Rx Signal In is filtered and recovered as serial data from the Unclocked Data Out. A flywheel synchronizer is used to extract a clock from the recovered serial data stream. The clock is available at Rx Sync Out and the retimed serial data is available at Clocked Data Out. The optimum time to sample the Clocked Data Out is on the falling edge of the Rx Sync Out clock signal.

The integrated peak values of the Rx Amplitude are compared with out-of-band noise levels and used to make a signal-to-noise assessment, which is available at Carrier Detect Out.

A Bandpass output is also available from the output of the first Rx filter stage, but will require buffering before use.

5. Application

5.1 Synchronous Modem Design Considerations

The CMX469A is an easily applied data pump, which can be used with many protocols. Because it is an MSK, or minimum shift keying, modem, it achieves a more noise resistant, higher data rate in a narrower bandwidth than other FSK (frequency shift keying) modems. This characteristic is especially important for wireless applications because it fundamentally determines the bandwidth of RF transmissions which are strictly limited and controlled by regulatory agencies. Using MSK signaling, the CMX469A data modem can achieve a 2400bps data rate within the typical 300-3000 Hz voice band of many common radios.

In order to achieve this advantage, an MSK modem must precisely control the bit rate and timing of the modulated Tx output signal bits. This control is asserted by the MSK modem with a data clock signal, which is output by the modem to pace the Tx data source (e.g. a microcontroller). The data clock signal, in effect, indicates when the Tx data source should provide the next Tx data bit to the modem. See Figure 4. Because this type of interface involves the use of a modem generated bit clock signal to control the timing of when new Tx data bits must be supplied from the data source, the interface is called synchronous.

Another characteristic of a synchronous modem is that, to receive data, it must first learn the data bit timing of the Rx signal stream before it can accurately demodulate Rx data bits. Accordingly, a synchronous modem undergoes a period of training or synchronization when it first begins to receive a stream of MSK modulated signal. During this initial receive phase, the received signal is evaluated over several bit times as the modem 'locks on' and achieves proper receive synchronization. The training sequence, called a preamble, is a specific data pattern which must be added to the 'front' of a transmit data stream with the start of each new transmission. A specific preamble data pattern (e.g. 16 bits of alternating 0,1,0,1... for the CMX469A) is used to optimize the training accuracy while minimizing the number of preamble bits required.

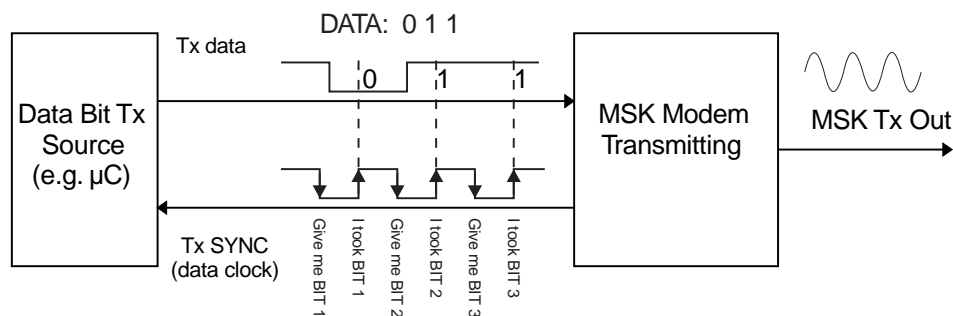

Figure 4: Synchronous Transmit Operation

Non-synchronous or asynchronous interfaces are commonly found in wired applications, which do not have the bandwidth efficiency requirements of wireless systems. A well-known example is the serial port of a personal computer. The serial port of the personal computer can transmit a 1200bps (or faster) data signal over a single Tx signal without using an additional data clock signal to control the precise rate and timing of data bits being transmitted to a typical telephone line data modem. Popular modem standards such as Bell 202 and v.23 use FSK signaling to pass such asynchronous serial port data signals over telephone systems.

Another aspect of asynchronous interfaces and modems is that they can carry data streams, which are not at the exact, nominal data rate. For example, a 1200bps FSK modem will typically operate properly when supplied with transmit data streams of 1201bps or 1199bps.

Because of the differences in synchronous and asynchronous interfaces, they cannot successfully operate if directly connected. In other words, a personal computer's RS232 serial port cannot directly interface to an MSK modem. This is because:

- The asynchronous interface may provide data bits too fast or too slow compared to the precise rate required for MSK signaling (a bit rate, or pacing, incompatibility).
- The timing of each specific data bit presented by an asynchronous interface will not be aligned with the precise bit timing required for MSK signaling (a bit timing incompatibility).

Synchronous and asynchronous interface can be successfully interfaced for applications requiring the advantages of both. This typically involves the use of data buffering and retiming circuits to resolve the timing and pacing issues.

5.2 Test Set Up

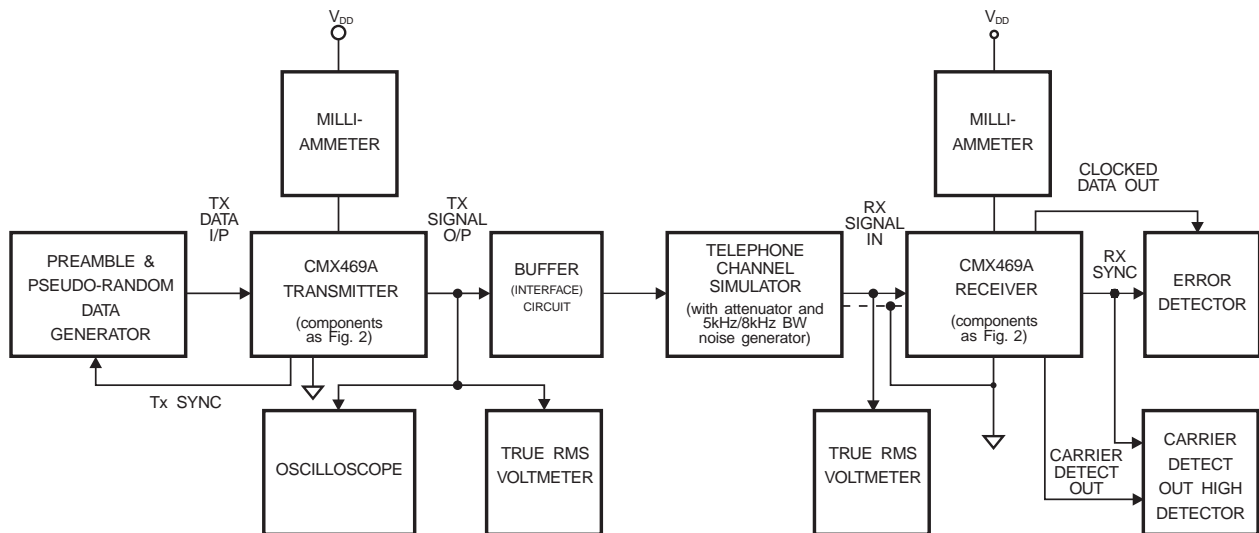

Figure 5: CMX469A Test Set-Up

5.3 Bit Error Rate

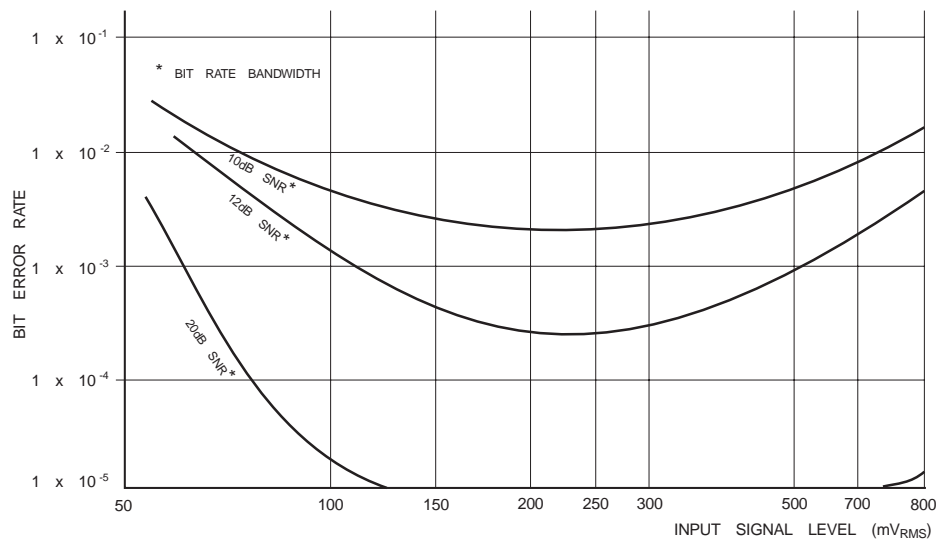

Figure 6: Typical Variation of Bit Error Rate with Input Level

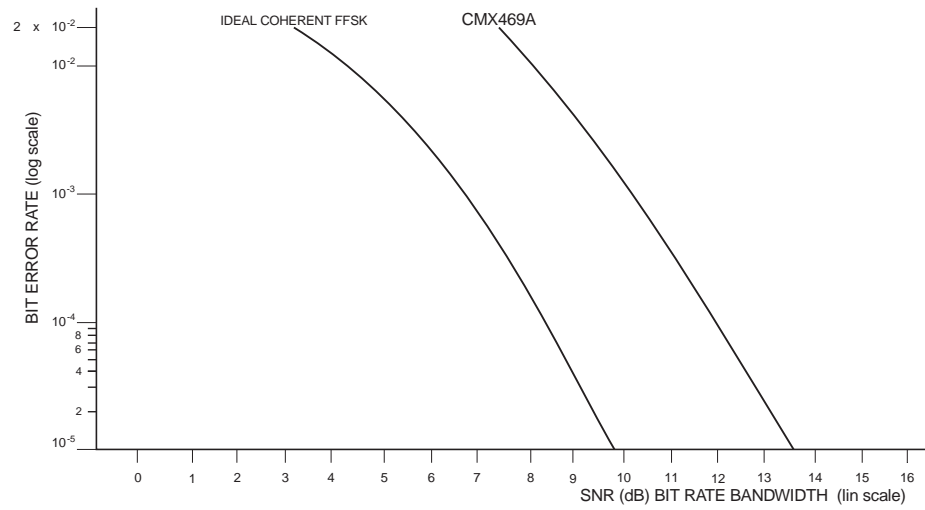

Figure 7: RX Bit-Error-Rate vs. Signal-to-Noise Ratio

6. Performance Specifications

6.1 Electrical Specifications

6.1.1 Absolute Maximum Limits

Exceeding these maximum ratings can result in damage to the device.

General	Notes	Min.	Max.	Units
Supply ($V_{DD}-V_{SS}$)		-0.3	7.0	V
Voltage on any pin to V_{SS}		-0.3	$V_{DD} + 0.3$	V
Current				
V_{DD}		-30	30	mA
V_{SS}		-30	30	mA
Any other pin		-20	20	mA
D3 / P6 Packages				
Total allowable Power dissipation at $T_{AMB} = 25^{\circ}\text{C}$			800	mW
Derating above 25°C			13	mW/ $^{\circ}\text{C}$ above 25°C
Operating Temperature		-40	85	$^{\circ}\text{C}$
Storage Temperature		-55	125	$^{\circ}\text{C}$
E2 Packages				
Total allowable Power dissipation at $T_{AMB} = 25^{\circ}\text{C}$			320	mW
Derating above 25°C			5.3	mW/ $^{\circ}\text{C}$ above 25°C
Operating Temperature		-40	85	$^{\circ}\text{C}$
Storage Temperature		-55	125	$^{\circ}\text{C}$

6.1.2 Operating Limits

Correct Operation of the device outside these limits is not implied.

	Notes	Min.	Max.	Units
Supply ($V_{DD}-V_{SS}$)		2.7	5.5	V
Operating Temperature		-40	85	$^{\circ}\text{C}$
Xtal Frequency	1	1.008	4.032	MHz

Operating Limits Notes

1. A Xtal frequency of 1.008MHz (1200/2400 baud only) or 4.032MHz is required for correct operation. A frequency tolerance of 0.1% is recommended, but ultimately the tolerance selected will depend upon system requirements.

6.1.3 Operating Characteristics

For the following conditions unless otherwise specified.

$V_{DD} = 2.7V$ @ $T_{AMB} = 25^{\circ}C$ and $V_{DD} = 3.0V$ to $5.5V$ at $T_{AMB} = -40^{\circ}C$ to $85^{\circ}C$

Xtal/Clock Frequency = 4.032MHz, Bit Rate = 1200 baud, Rx Input Level = $300mV_{RMS}$,

	Notes	Min.	Typ.	Max.	Units
Static Values					
I_{DD} (V _{DD} = 5.0V)					
RX Enabled, TX Disabled -	2		3.6		mA
RX and TX Enabled	2		4.5		mA
RX and TX Disabled	2		650		μA
I_{DD} (V _{DD} = 3.0V)					
RX Enabled, TX Disabled	2		1.5		mA
RX and TX Enabled	2		2.0		mA
RX and TX Disabled	2		300		μA
Logic '1' Level	1	70%			V _{DD}
Logic '0' Level	1			30%	V _{DD}
Digital Output Impedance			4.0		kΩ
Analog and Digital Input Impedance		100			kΩ
TX Output Impedance (V _{DD} = 5.0V)			0.6	1.0	kΩ
Dynamic Values					
Receiver					
Signal Input Dynamic Range					
SNR = 50dB	3, 4	100	230	1000	mV _{RMS}
Bit Error Rate at SNR = 12dB	4, 5				
1200bps			2.5		10 ⁻⁴
2400bps			1.5		10 ⁻³
4800bps			1.5		10 ⁻³
Bit Error Rate at SNR = 20dB	4, 5				
1200/2400/4800bps			<1.0		10 ⁻⁸
Receiver Synchronization at SNR = 12dB					
Probability of bit 16 being correct	7		99.5		%
Carrier Detect					
Sensitivity	1, 7, 8			150	mV _{RMS}
Probability of CD being high after bit 16:					
With SNR = 12dB	9		99.5		%
With 230mV _{RMS} Noise and No Signal	9		5		%

	Notes	Min.	Typ.	Max.	Units
Transmitter Output					
TX Output Level	1		775		mV _{RMS}
Output Level Variation					
1200/1800Hz		0		±1.0	dB
1200/2400Hz		0		±1.0	dB
2400/4800Hz		0		±1.0	dB
Output Distortion	10		3.0	5.0	%
3rd Harmonic Distortion	10		2.0	3.0	%
Isochronous Distortion					
1200Hz - 1800Hz/1800Hz - 1200Hz			25.0	40.0	μs
1200Hz - 2400Hz/2400Hz - 1200Hz			20.0	30.0	μs
2400Hz - 4800Hz/4800Hz - 2400Hz			10.0	20.0	μs
Logic '1' Carrier Frequency					
1200bps	6		1200		Hz
2400bps	6		1200		Hz
4800bps	6		2400		Hz
Logic '0' Carrier Frequency					
1200bps	6		1800		Hz
2400bps	6		2400		Hz
4800bps	6		4800		Hz

Operating Characteristics Notes:

1. Measured at $V_{DD} = 5.0$ volts. Signal levels and thresholds are proportional to V_{DD} .
2. Excludes any current drawn by external components, but includes current drawn by the crystal components.
3. See Figure 6: Typical Variation of Bit Error Rate with Input Level
4. SNR = Signal-to-Noise Ratio in the Bit-Rate-Bandwidth.
5. See Figure 7: RX Bit-Error-Rate vs. Signal-to-Noise Ratio
6. Dependent upon Xtal tolerance
7. With an alternating (1010...) pattern.
8. Measured with a 150mV_{RMS} input signal (no noise).
9. A signal level of 230mV_{RMS} is used in C.D. probability measurements. Noise bandwidth is 5kHz (1200/2400 baud operation) or 8kHz (4800 baud operation). See Section 3, Note 2 for details on optimizing noise immunity.
10. For an unmodulated carrier

6.1.4 Timing

6.1.4.1 1200bps

Characteristics		Note	Min.	Typ.	Max.	Unit
TX Enable to TX Sync Rise Time	t_{SYNC}			416		μs
TX Delay, Signal to Disable Time	t_{ESET}		2.0		800	μs
Data Set-Up Time	t_{DSET}	1	2.0			μs
Data Hold Time	t_{DH}		2.0			μs
TX Delay to O/P Time	t_{TXD}			1.2		μs
TX Data Rate Period	t_{TDR}			833		μs
RX Data Rate Period	t_{RDR}		800		865	μs
Undetermined State					2.0	μs
Internal RX Delay	t_{ID}			1.5		ms

Notes:

1. Consider the Xtal/clock tolerance.
2. All TX timings are related to the TX Sync Output.

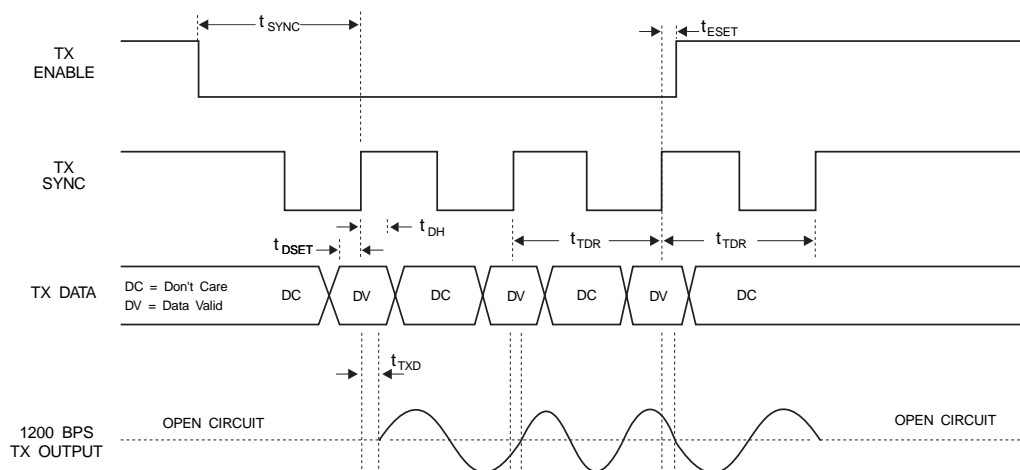

Figure 8: Transmitter Timing: 1200bps

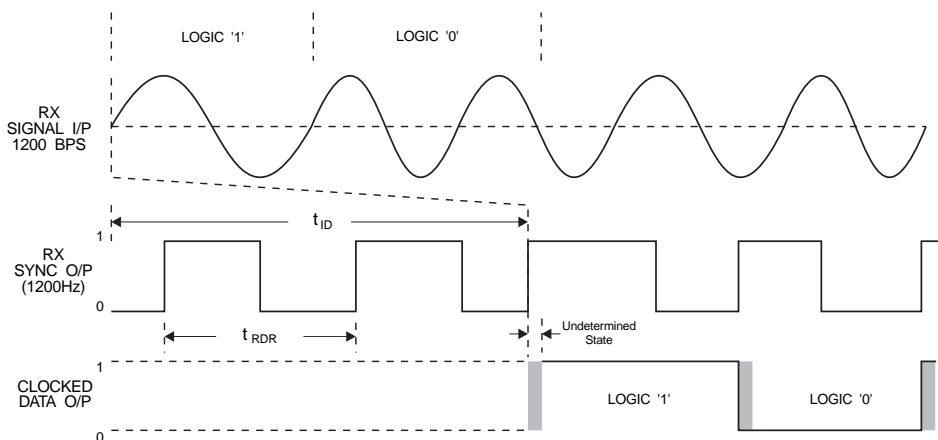

Figure 9: Receiver Timing Diagram: 1200bps

6.1.4.2 2400bps

Characteristics		Note	Min.	Typ.	Max.	Unit
TX Enable to TX Sync Rise Time	t_{SYNC}			208		μs
TX Delay, Signal to Disable Time	t_{ESET}		2.0		400	μs
Data Set-Up Time	t_{DSET}	1	2.0			μs
Data Hold Time	t_{DH}		2.0			μs
TX Delay to O/P Time	t_{TXD}			1.2		μs
TX Data Rate Period	t_{TDR}			416		μs
RX Data Rate Period	t_{RDR}		400		433	μs
Undetermined State					2.0	μs
Internal RX Delay	t_{ID}			1.5		ms

Notes:

1. Consider the Xtal/Clock tolerance.
2. All TX timings are related to the TX Sync Output.

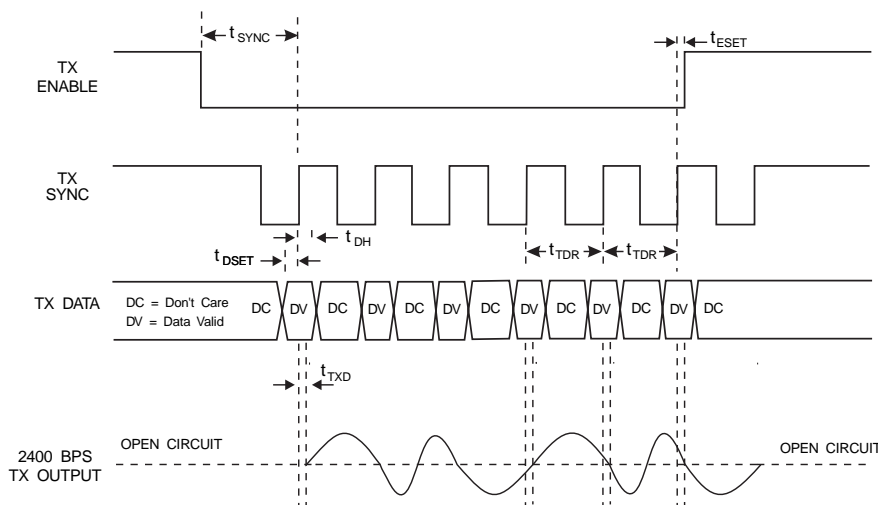

Figure 10: Transmitter Timing: 2400bps

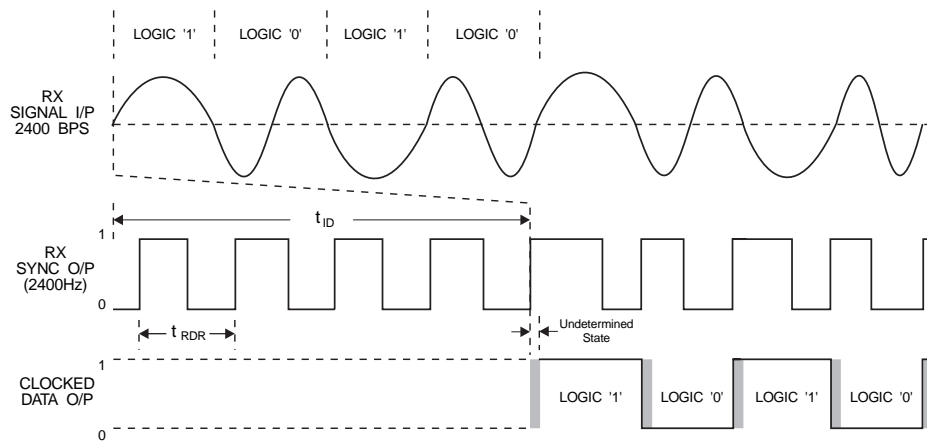

Figure 11: Receiver Timing: 2400bps

6.1.4.3 4800bps

Characteristics		Note	Min.	Typ.	Max.	Unit
TX Enable to TX Sync Rise Time	t_{SYNC}			104		μs
TX Delay, Signal to Disable Time	t_{ESET}		2.0		200	μs
Data Set-Up Time	t_{DSET}	1	2.0			μs
Data Hold Time	t_{DH}		2.0			μs
TX Delay to O/P Time	t_{TXD}			1.2		μs
TX Data Rate Period	t_{TDR}			208		μs
RX Data Rate Period	t_{RDR}		200		216	μs
Undetermined State					2.0	μs
Internal RX Delay	t_{ID}			1.0		ms

Notes:

1. Consider the Xtal/Clock tolerance.
2. All TX timings are related to the TX Sync Output.

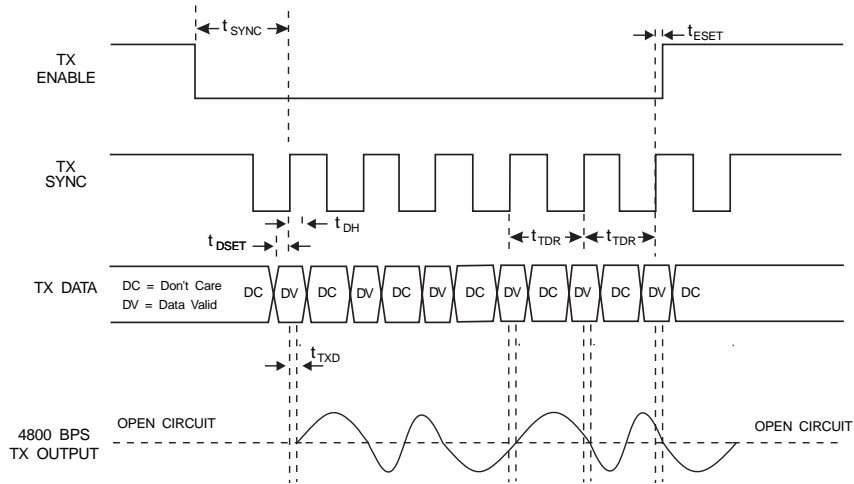

Figure 12: Transmitter Timing: 4800bps

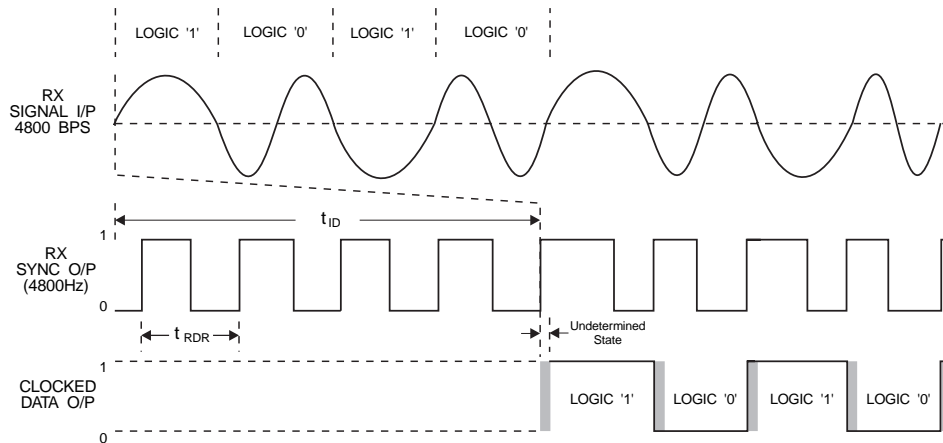

Figure 13: Receiver Timing: 4800bps

6.2 Packages

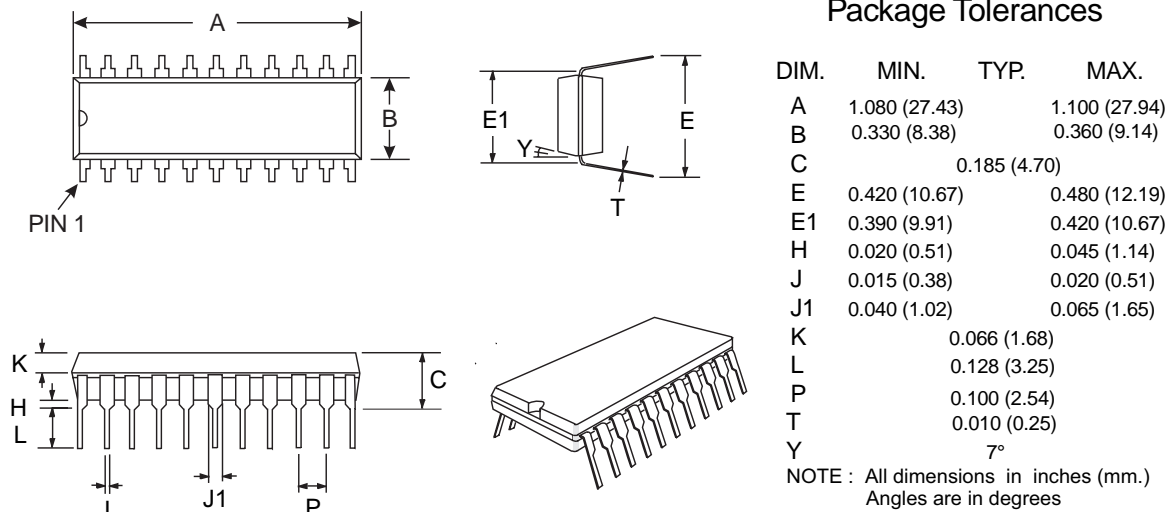

Figure 14: 22-pin PDIP Mechanical Outline: Order as part no. CMX469AP6

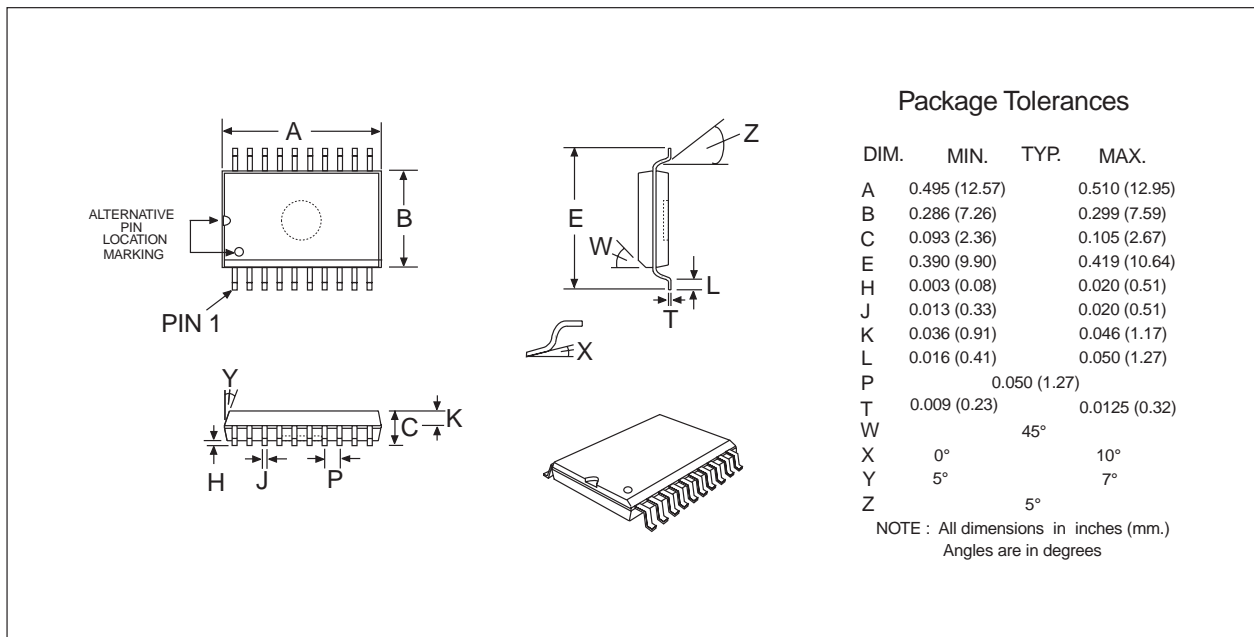

Figure 15: 20-pin SOIC Mechanical Outline: Order as part no. CMX469AD3

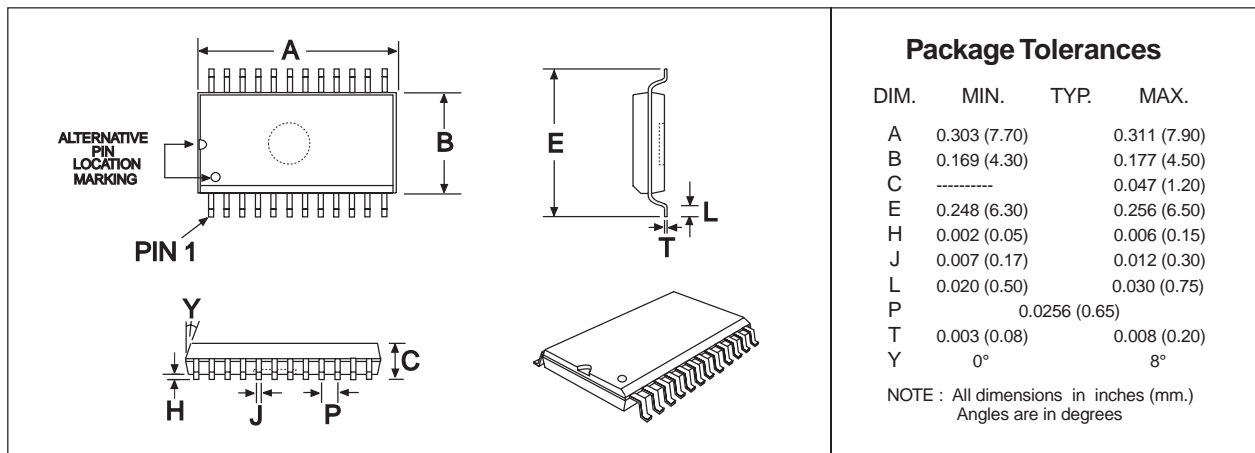

Figure 16: 24-pin TSSOP Mechanical Outline: *Order as part no. CMX469AE2*