

- NOTES:**
- MOUNTING:** Mounts in a  $\phi .171 \pm .002$  [ $\phi 4.34\text{mm} \pm .05$ ] panel hole on .250 [6.35mm] centers. Panel thickness .031 [.8mm] to .094 [2.39mm]. Panel hole should be deburred, but not chamfered.
  - ASSEMBLY:** Insert lens through panel hole, slide RNG 132 retainer on back of lens. PCB mounted LEDs slide into lens when the panel cover is closed or the PCB card is inserted into the case.
  - MATERIAL:** Polycarbonate, UL 94-V2
  - U.S. & Foreign Pat. Issued & Pend.**

| REVISIONS |      |                           |         |          |
|-----------|------|---------------------------|---------|----------|
| ECN#      | REV. | DESCRIPTION               | DATE    | INITIALS |
|           | 001  | REVISED PER ECR111009AZ01 | 4-23-10 | SMU      |

RETAINER  
(ORDER SEPARATELY)

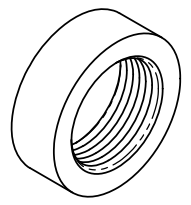

RNG 132

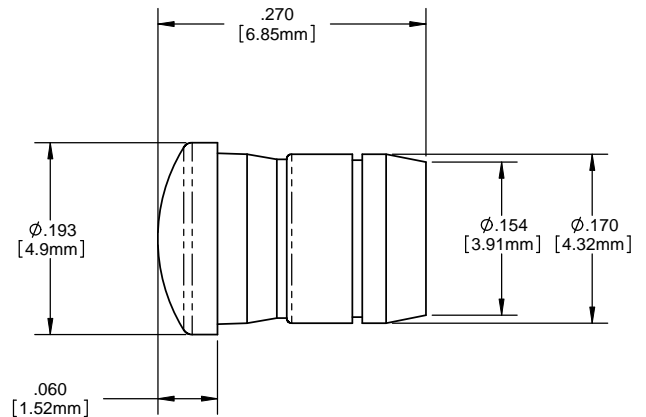
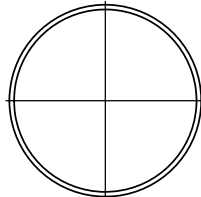
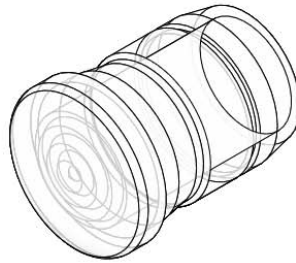

ORDERING CODE : **SMC 170 XXX**

MODEL

| LENS COLOR |                    |
|------------|--------------------|
| RTP        | RED TRANSPARENT    |
| ATP        | AMBER TRANSPARENT  |
| GTP        | GREEN TRANSPARENT  |
| BTP        | BLUE TRANSPARENT   |
| YTP        | YELLOW TRANSPARENT |
| CTP        | CLEAR TRANSPARENT  |

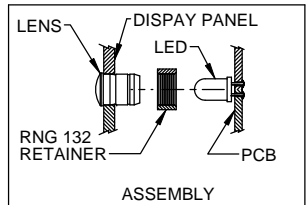

|  |  |  |                                  |
|--|--|--|----------------------------------|
| <small>UNLESS OTHERWISE SPECIFIED DIMENSIONS ARE IN INCHES</small><br>ANGLES    DECIMALS<br>$\pm 1^\circ$ .X $\pm .020$<br>FINISH     .XXX $\pm .010$<br>.XXX $\pm .005$<br><small>BREAK ALL CORNERS AND SHARP EDGES 90° MIN</small> | <b>MATERIAL</b><br>POLYCARBONATE,<br>UL 94-V2        | <b>VISUAL COMMUNICATIONS COMPANY, INC.</b><br><small>190 Bosstick Boulevard, Suite 101 San Marcos, CA 92069 USA<br/>         Phone (760) 560-1300 Fax (760) 560-1301 email vccsales@vccite.com</small> |                                  |
|  | <b>FINISH</b><br>SEE NOTES                           | <b>TITLE: 3MM ROUND FRESNEL LOW PROFILE LENS</b>   |                                  |
| <small>THIRD ANGLE PROJECTION</small><br>  | <small>APPROVAL</small><br>DRAWN: SMU<br>CHECKED: DZ | <small>DATE</small><br>4-23-10<br>4-23-10  | <small>SIZE</small><br><b>B</b>  |
| <small>DO NOT SCALE DRAWING</small>  | <small>SCALE: 12:1</small>                           | <small>DWG. NO.</small><br><b>SMC 170 XXX</b>  | <small>REV</small><br><b>001</b> |
|  |  | <small>SHEET 1 OF 1</small>  |                                  |