

PS9331L, PS9331L2

Preliminary Data Sheet

Specifications in this document are tentative and subject to change.

2.5 A OUTPUT CURRENT, HIGH CMR, IGBT GATE DRIVE, 6-PIN SDIP PHOTOCOUPLER

Nov 30, 2012

DESCRIPTION

The PS9331L and PS9331L2 are optical coupled isolators containing a GaAlAs LED on the input side and a photo diode, a signal processing circuit and power MOSFETs on the output side on one chip.

The PS9331L and PS9331L2 are in 6-pin plastic SDIP (Shrink Dual In-line Package). The PS9331L2 has 8 mm creepage distance. The mount area of 6-pin plastic SDIP is half size of 8-pin DIP.

The PS9331L and PS9331L2 are designed specifically for high common mode transient immunity (CMR) and high switching speed. It is suitable for driving IGBTs and MOS FETs.

The PS9331L is lead bending type (Gull-wing) for surface mounting.

The PS9331L2 is lead bending type for long creepage distance (Gull-wing) for surface mount.

FEATURES

- Long creepage distance (8 mm MIN.: PS9331L2)
- Half size of 8-pin DIP
- Peak output current (2.5 A MAX., 2.0 A MIN.)
- High speed switching (t_{PLH} , t_{PHL} = 200 ns MAX.)
- High common mode transient immunity (CM_H , CM_L = ± 50 kV/ μ s MIN.)
- Operating Ambient Temperature (125 °C)
- Embossed tape product : PS9331L-E3, PS9331L2-E3: 2 000 pcs/reel
- Pb-Free product

APPLICATIONS

- IGBT, Power MOS FET Gate Driver
- Industrial inverter
- AC Servo

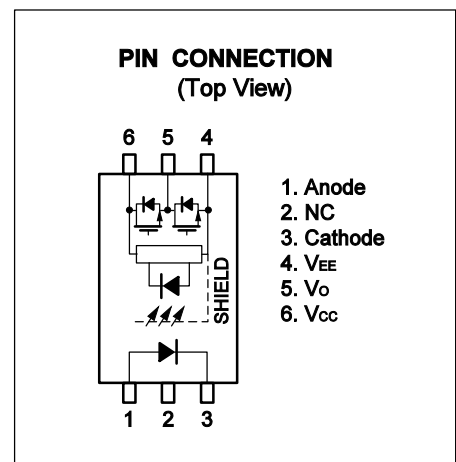

PS9331L, PS9331L2

PACKAGE DIMENSIONS (UNIT: mm)

Lead Bending Type (Gull-wing) For Surface Mount

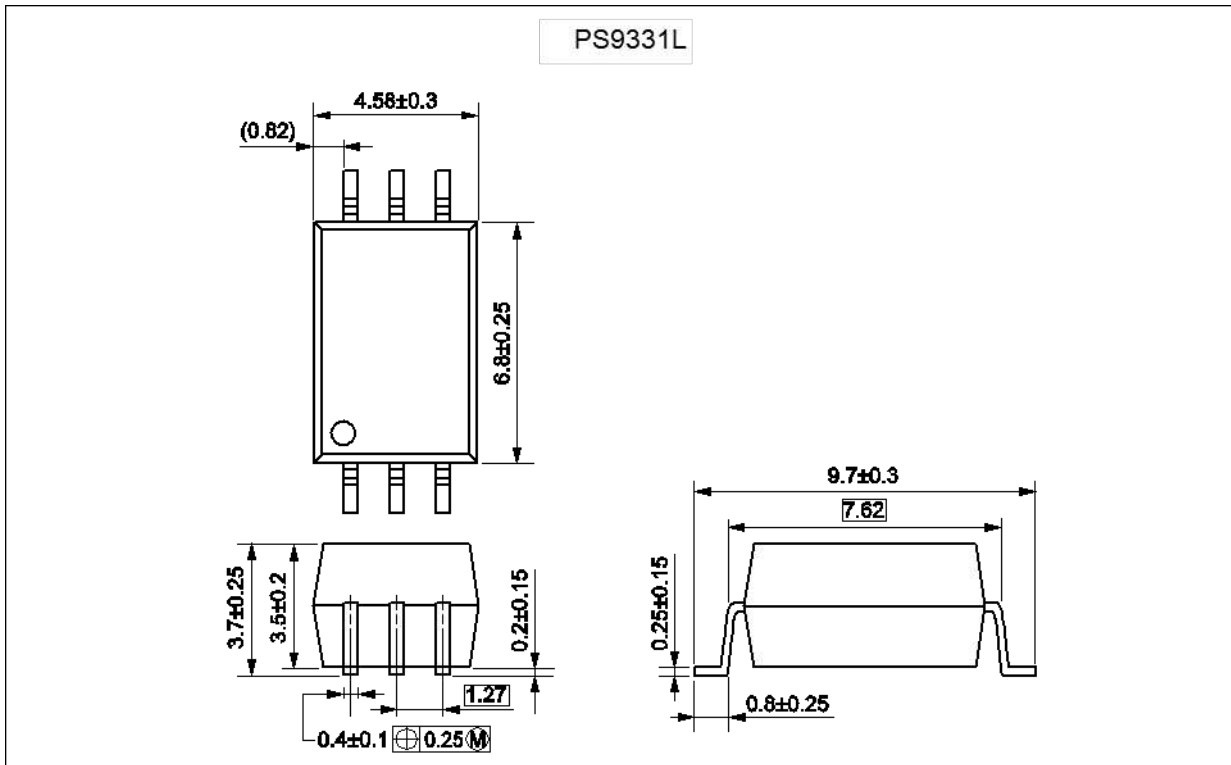

Lead Bending Type (Gull-wing) For Long Creepage Distance (Surface Mount)

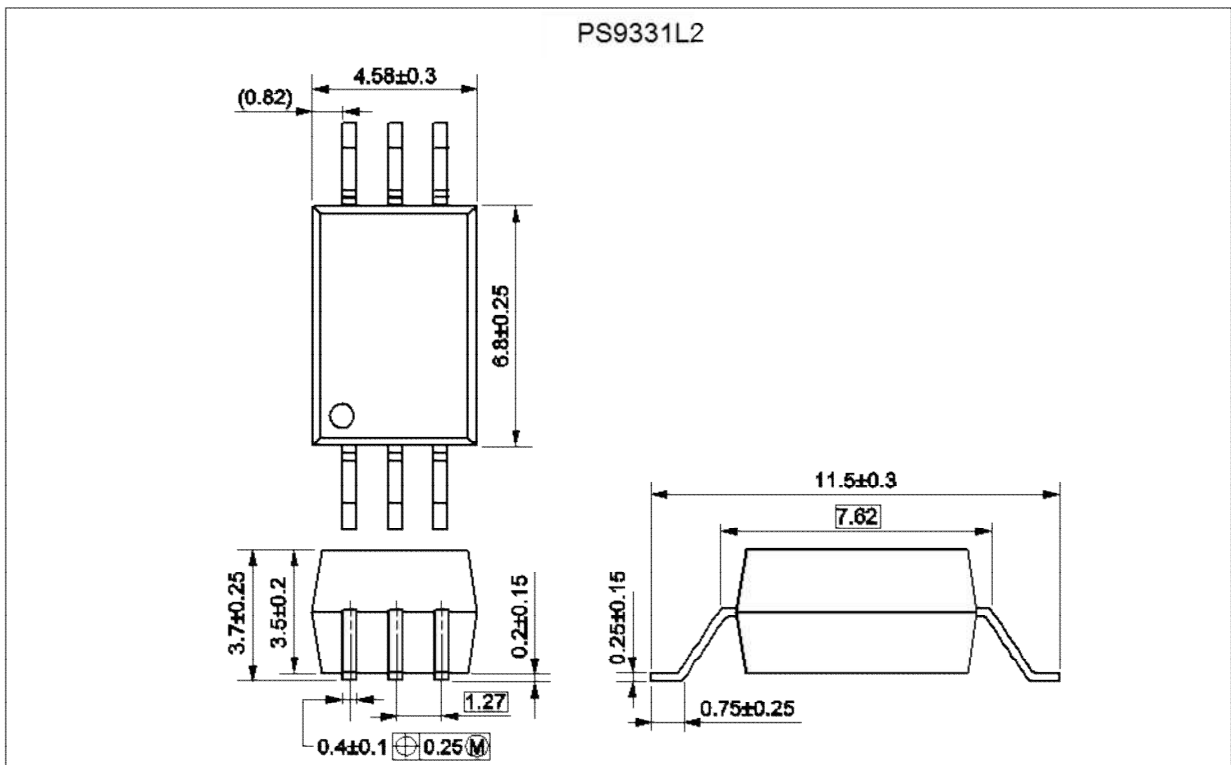

PS9331L, PS9331L2

PHOTOCOUPLER CONSTRUCTION

Parameter	PS9331L	PS9331L2
Air Distance (MIN.)	7 mm	8 mm
Outer Creepage Distance (MIN.)	7 mm	8 mm
Isolation Distance (MIN.)	0.4 mm	0.4 mm

MARKING EXAMPLE

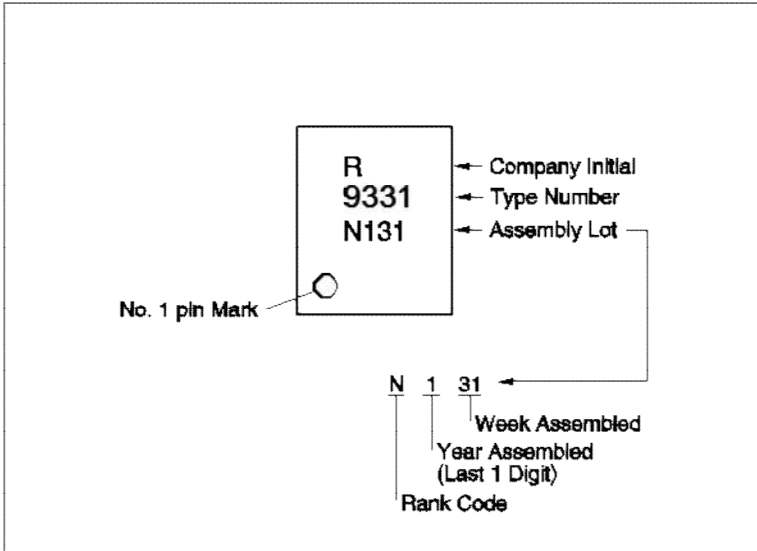

PS9331L, PS9331L2

ABSOLUTE MAXIMUM RATINGS (T_A = 25°C, unless otherwise specified)

Parameter		Symbol	Ratings	Unit
Diode	Forward Current	I _F	25	mA
	Peak Transient Forward Current (Pulse Width < 1 μs)	I _{F (TRAN)}	1.0	A
	Reverse Voltage	V _R	5	V
	Power Dissipation *1	P _D	45	mW
Detector	High Level Peak Output Current *2	I _{OH (PEAK)}	2.5	A
	Low Level Peak Output Current *2	I _{OL (PEAK)}	2.5	A
	Supply Voltage	(V _{CC} - V _{EE})	0 to 35	V
	Output Voltage	V _O	0 to V _{CC}	V
	Power Dissipation *3	P _C	250	mW
Isolation Voltage *4		BV	5 000	Vr.m.s.
Operating Frequency		f	50	kHz
Operating Ambient Temperature		T _A	-40 to +125	°C
Storage Temperature		T _{stg}	-55 to +150	°C

- Notes: *1. Reduced to 1.2 mW/°C at T_A = 110°C or more.
 *2. Maximum pulse width = 10 μs, Maximum duty cycle = 0.5%
 *3. Reduced to 3.9 mW/°C at T_A = 85°C or more.
 *4. AC voltage for 1 minute at T_A = 25°C, RH = 60% between input and output.
 Pins 1-3 shorted together, 4-6 shorted together.

RECOMMENDED OPERATING CONDITIONS

Parameter	Symbol	MIN.	TYP.	MAX.	Unit
Supply Voltage	(V _{CC} - V _{EE})	15		30	V
Forward Current (ON)	I _{F (ON)}	7	10	16	mA
Forward Voltage (OFF)	V _{F (OFF)}	-2		0.8	V
Operating Ambient Temperature	T _A	-40		125	°C

PS9331L, PS9331L2

ELECTRICAL CHARACTERISTICS (at RECOMMENDED OPERATING CONDITIONS, $V_{EE} = GND$, unless otherwise specified)

Parameter		Symbol	Conditions	MIN.	TYP. ^{*1}	MAX.	Unit
Diode	Forward Voltage	V_F	$I_F = 10 \text{ mA}, T_A = 25^\circ\text{C}$	1.35	1.56	1.75	V
	Reverse Current	I_R	$V_R = 3 \text{ V}, T_A = 25^\circ\text{C}$			10	μA
	Input Capacitance	C_{IN}	$f = 1 \text{ MHz}, V_F = 0 \text{ V}$		30		pF
Detector	High Level Output Current	I_{OH}	$V_O = (V_{CC} - 4 \text{ V})$ ^{*2}	0.5	2.0		A
			$V_O = (V_{CC} - 15 \text{ V})$ ^{*3}	2.0			
	Low Level Output Current	I_{OL}	$V_O = (V_{EE} + 2.5 \text{ V})$ ^{*2}	0.5	2.0		A
			$V_O = (V_{EE} + 15 \text{ V})$ ^{*3}	2.0			
	High Level Output Voltage	V_{OH}	$I_F = 10 \text{ mA}, I_O = -100 \text{ mA}$ ^{*4}	$V_{CC} - 3.0$	$V_{CC} - 1.3$		V
	Low Level Output Voltage	V_{OL}	$I_F = 0 \text{ mA}, I_O = 100 \text{ mA}$		0.1	0.5	V
	High Level Supply Current	I_{CCH}	$I_F = 10 \text{ mA}, I_O = 0 \text{ mA}$		1.2	2.0	mA
	Low Level Supply Current	I_{CCL}	$I_F = 0 \text{ mA}, I_O = 0 \text{ mA}$		1.2	2.0	mA
Coupled	Threshold Input Current (L → H)	I_{FLH}	$I_O = 0 \text{ mA}, V_O > 5 \text{ V}$		1.8	5.0	mA
	Threshold Input Voltage (H → L)	V_{FHL}	$I_O = 0 \text{ mA}, V_O < 5 \text{ V}$	0.8			V

- Notes: *1. Typical values at $T_A = 25^\circ\text{C}$, $V_{CC} - V_{EE} = 30 \text{ V}$.
 *2. Maximum pulse width = 50 μs , Maximum duty cycle = 0.5%.
 *3. Maximum pulse width = 10 μs , Maximum duty cycle = 0.2%.
 *4. V_{OH} is measured with the DC load current in this testing.

SWITCHING CHARACTERISTICS (at RECOMMENDED OPERATING CONDITIONS, $V_{EE} = GND$, unless otherwise specified)

Parameter	Symbol	Conditions	MIN.	TYP. ^{*1}	MAX.	Unit
Propagation Delay Time (L → H)	t_{PLH}	$R_g = 10 \Omega, C_g = 10 \text{ nF},$ $f = 10 \text{ kHz},$ Duty Cycle = 50% ^{*2} , $I_F = 10 \text{ mA}$		150	200	ns
Propagation Delay Time (H → L)	t_{PHL}			150	200	ns
Pulse Width Distortion (PWD)	$ t_{PHL} - t_{PLH} $				75	ns
Propagation Delay Time (Difference Between Any Two Products)	$t_{PHL} - t_{PLH}$			-90	90	ns
Rise Time	t_r				40	ns
Fall Time	t_f				40	ns
Common Mode Transient Immunity at High Level Output	$ CM_H $		$T_A = 25^\circ\text{C}, I_F = 10 \text{ mA},$ $V_{CC} = 30 \text{ V}, V_{CM} = 1.5 \text{ kV}$	50		
Common Mode Transient Immunity at Low Level Output	$ CM_L $	$T_A = 25^\circ\text{C}, I_F = 0 \text{ mA},$ $V_{CC} = 30 \text{ V}, V_{CM} = 1.5 \text{ kV}$	50			$\text{kV}/\mu\text{s}$

- Notes: *1. Typical values at $T_A = 25^\circ\text{C}$, $V_{CC} - V_{EE} = 30 \text{ V}$.
 *2. This load condition is equivalent to the IGBT load at 1 200 V/75 A.

TEST CIRCUIT

Fig. 1 I_{OH} Test Circuit

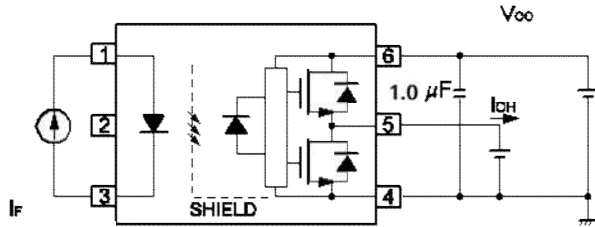

Fig. 2 I_{OL} Test Circuit

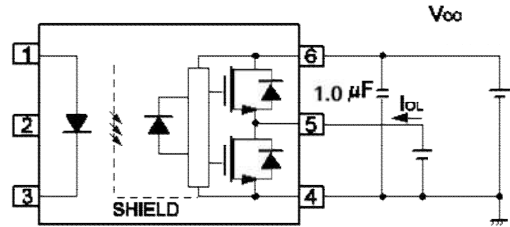

Fig. 3 V_{OH} Test Circuit

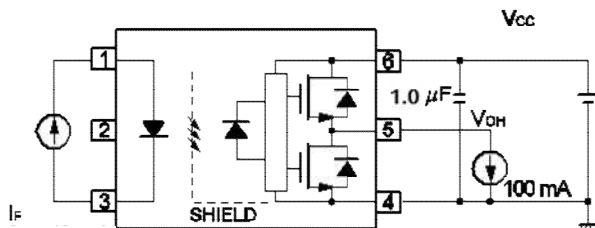

Fig. 4 V_{OL} Test Circuit

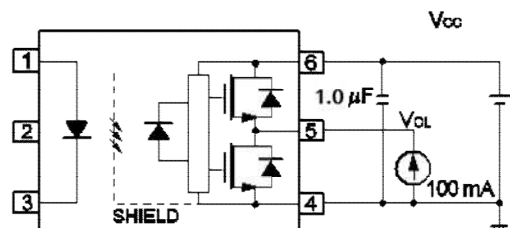

Fig. 5 I_{FLH} Test Circuit

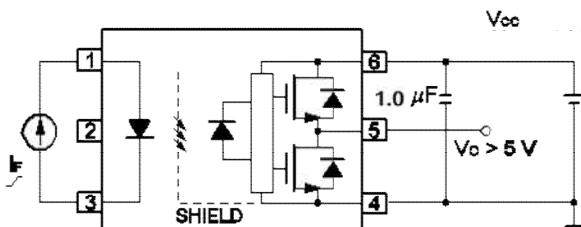
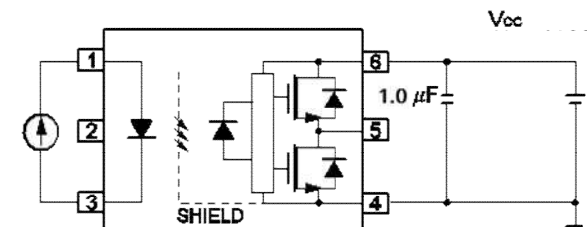

Fig. 6 I_{CCH}/I_{CCL} Test Circuit



I_{CCL} : I_F = 0 mA
 I_{CCH} : I_F = 10 mA

PS9331L, PS9331L2

Fig. 7 t_{PLH} , t_{PHL} , t_r , t_f Test Circuit and Wave Forms

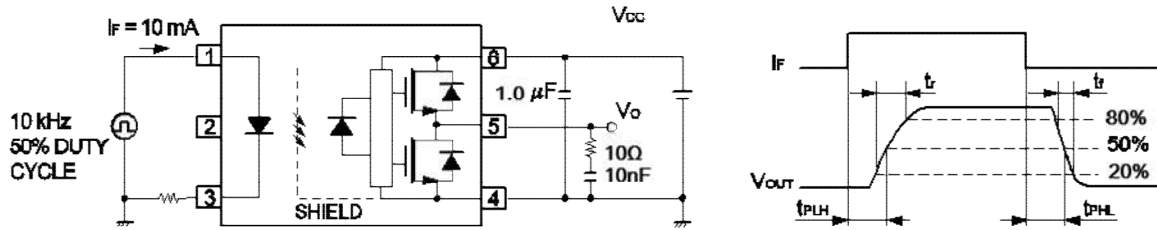
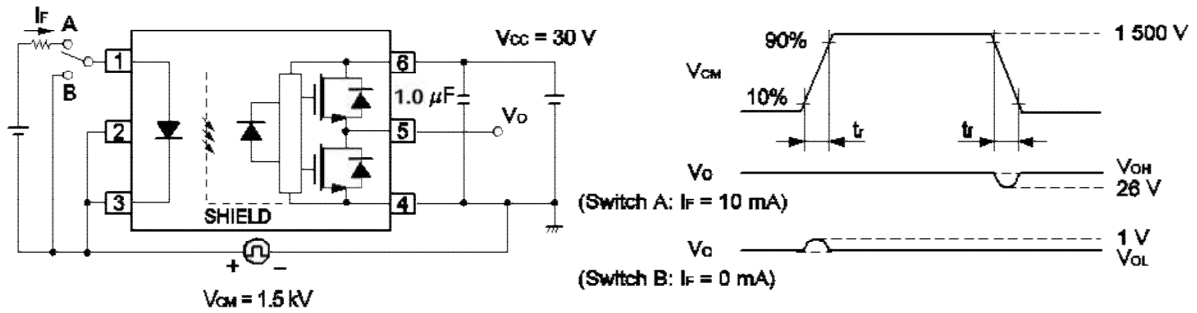

Fig. 8 CMR Test Circuit and Wave Forms



- Remarks**
1. Common Mode Transient Immunity at High Level Output is the maximum value of dV_{CM}/dt at which the output remains High Level (e.g. $V_o > 15$ V).
 2. Common Mode Transient Immunity at Low Level Output is the maximum value of dV_{CM}/dt at which the output remains Low Level (e.g. $V_o < 1.0$ V).

PS9331L, PS9331L2

TAPING SPECIFICATIONS (UNIT: mm)

Outline and Dimensions (Tape)

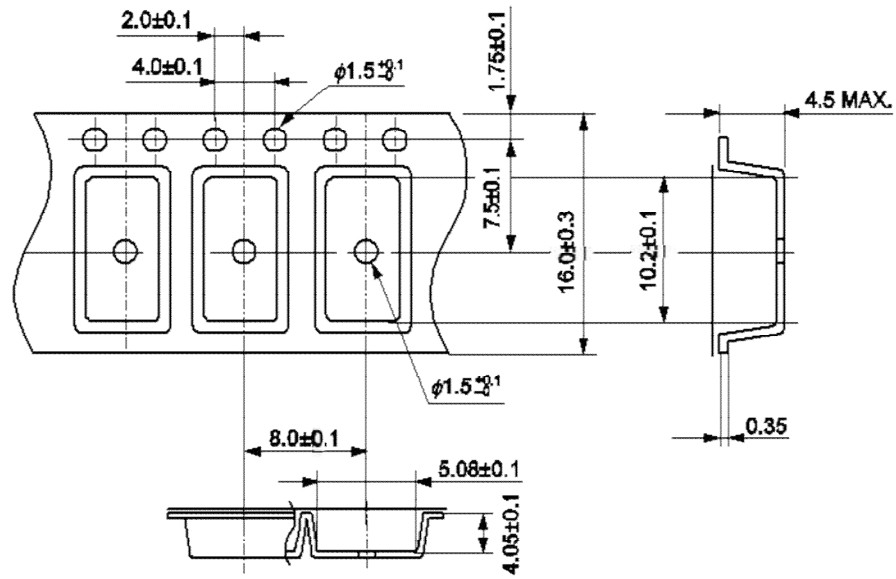

Tape Direction

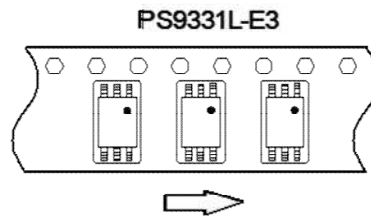

Outline and Dimensions (Reel)

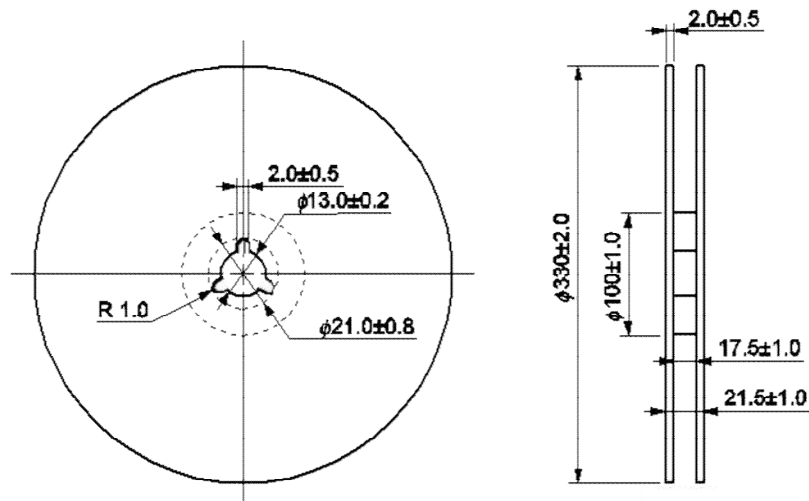

Packing: 2 000 pcs/reel

PS9331L, PS9331L2

Outline and Dimensions (Tape)

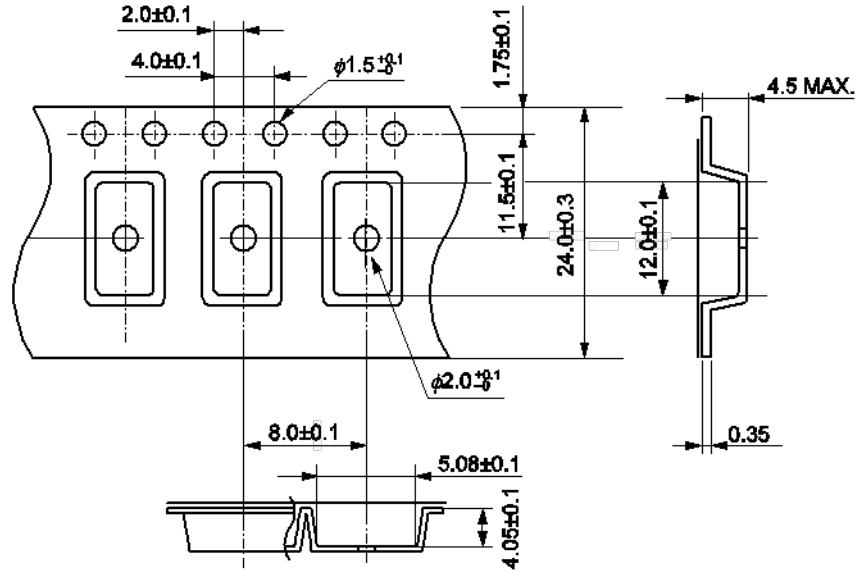

Tape Direction

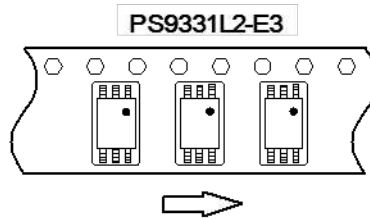

Outline and Dimensions (Reel)

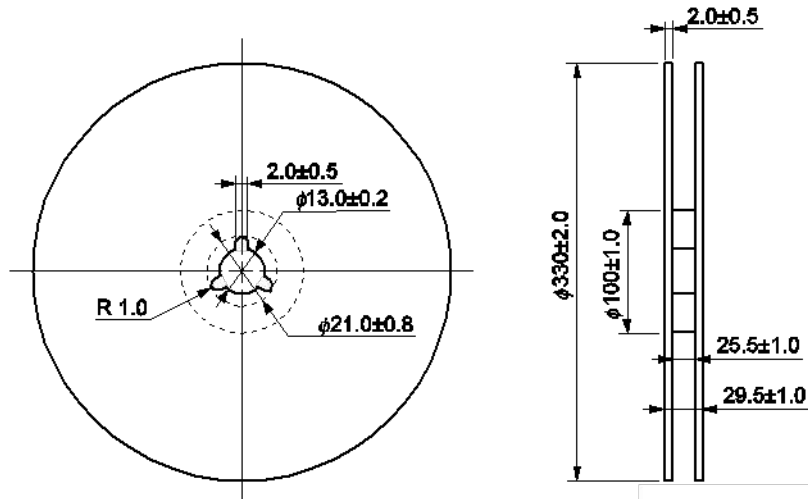

Packing: 2 000 pcs/reel

PS9331L, PS9331L2

RECOMMENDED MOUNT PAD DIMENSIONS (UNIT: mm)

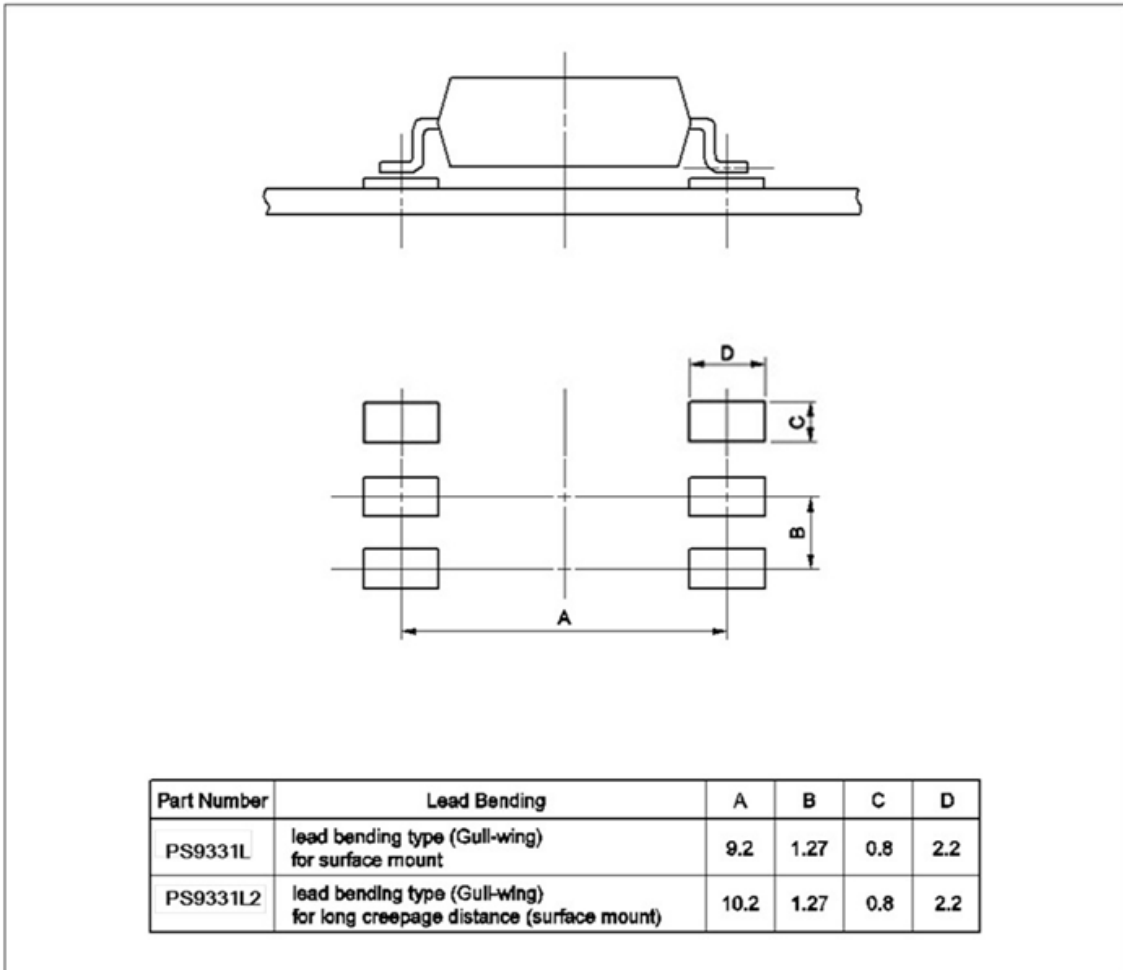

NOTES ON HANDLING (UNIT: mm)

CAUTIONS REGARDING NOISE

Be aware that when voltage is applied suddenly between the photocoupler's input and output at startup, the output transistor may enter the on state, even if the voltage is within the absolute maximum ratings.

USAGE CAUTIONS

1. This product is weak for static electricity by designed with high-speed integrated circuit so protect against static electricity when handling.
2. Board designing
 - (1) By-pass capacitor of more than 1.0 μF is used between V_{CC} and GND near device. Also, ensure that the distance between the leads of the photocoupler and capacitor is no more than 10 mm.
 - (2) When designing the printed wiring board, ensure that the pattern of the IGBT collectors/emitters is not too close to the input block pattern of the photocoupler.

If the pattern is too close to the input block and coupling occurs, a sudden fluctuation in the voltage on the IGBT output side might affect the photocoupler's LED input, leading to malfunction or degradation of characteristics. (If the pattern needs to be close to the input block, to prevent the LED from lighting during the off state due to the abovementioned coupling, design the input-side circuit so that the bias of the LED is reversed, within the range of the recommended operating conditions, and be sure to thoroughly evaluate operation.)
 - (3) Pin 2 (which is an NC^{*1} pin) can either be connected directly to the GND pin on the LED side or left open. Unconnected pins should not be used as a bypass for signals or for any other similar purpose because this may degrade the internal noise environment of the device.

Note: *1. NC: Non-Connection (No Connection).
3. Make sure the rise/fall time of the forward current is 0.5 μs or less.
4. In order to avoid malfunctions, make sure the rise/fall slope of the supply voltage is 3 V/ μs or less.
5. Avoid storage at a high temperature and high humidity.

PS9331L, PS9331L2

<p>Caution GaAs Products</p>	<p>This product uses gallium arsenide (GaAs). GaAs vapor and powder are hazardous to human health if inhaled or ingested, so please observe the following points.</p> <ul style="list-style-type: none">• Follow related laws and ordinances when disposing of the product. If there are no applicable laws and/or ordinances, dispose of the product as recommended below.<ol style="list-style-type: none">1. Commission a disposal company able to (with a license to) collect, transport and dispose of materials that contain arsenic and other such industrial waste materials.2. Exclude the product from general industrial waste and household garbage, and ensure that the product is controlled (as industrial waste subject to special control) up until final disposal.• Do not burn, destroy, cut, crush, or chemically dissolve the product.• Do not lick the product or in any way allow it to enter the mouth.
-------------------------------------	--