

Inductive Sensor Analog Front End Device

Features:

- Complete Inductance Measurement System:
 - Low-Impedance Current Driver
 - Sensor/Reference Coil Multiplexer
 - High-Frequency Detector
- Operating Voltage: 2.7 to 5.5V
- Low-Power Standby Mode
- Gain and Frequency set by external passive components

Typical Applications:

- Harsh environment inductive keyboards
- Inductive rotational sensor interface
- Inductive displacement sensor interface
- Inductive force sensor interface

Description:

The MCP2036 Inductive Sensor Analog Front End (AFE) combines all the necessary analog functions for a complete inductance measurement system.

The device includes:

- High-frequency, current-mode coil driver for exciting the sensor coil.
- Synchronous detector for converting AC sense voltages into DC levels.
- Output amplifier/filter to improve resolution and limit noise.
- Virtual ground reference generator for single supply operation.

The device is available in 14-pin PDIP, SOIC and 16-pin QFN packages:

Package Types

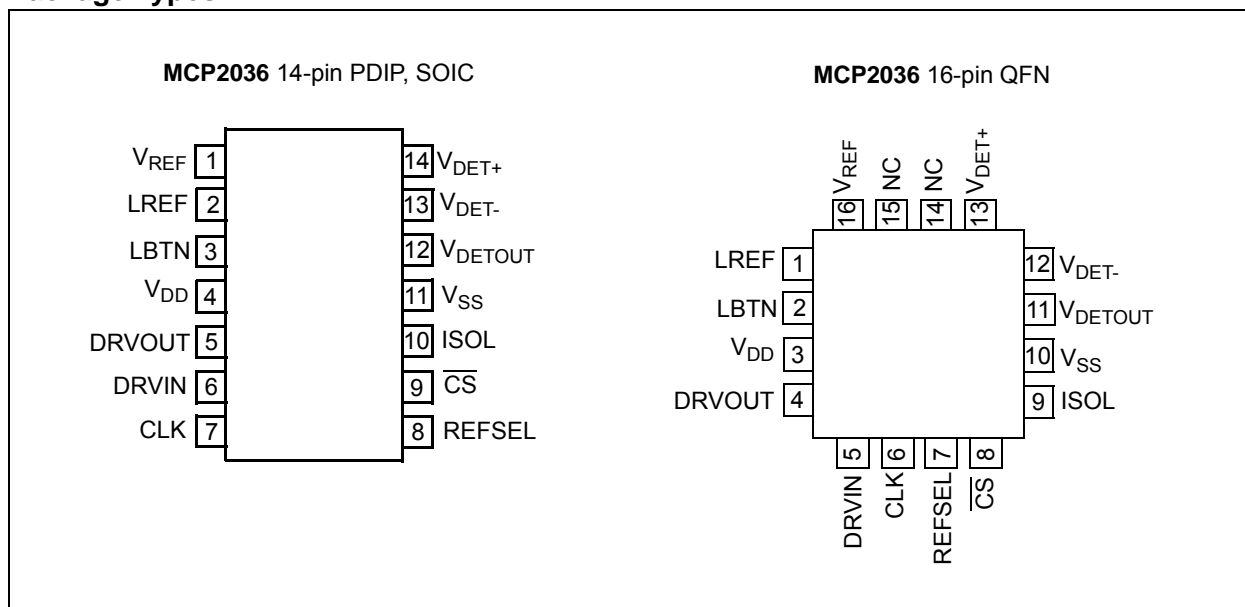

MCP2036

1.0 FUNCTIONAL DESCRIPTION

The MCP2036 measures a sensor coil's impedance by exciting the coil with a pulsed DC current and measuring the amplitude of the resulting AC voltage waveform. The drive current is generated by the on-chip current amplifier/driver which takes the high-frequency triangular waveform present on the DRVIN input, and amplifies it into the pulsed DC current for exciting the series combination of the sensor coils.

The AC voltages generated across the coils, are then capacitively coupled into the LBTN and LREF inputs. An input resistance of 2K between the inputs and the virtual ground offsets the AC input voltages up to the signal ground generated by the reference voltage generator, as shown in [Figure 1-1](#).

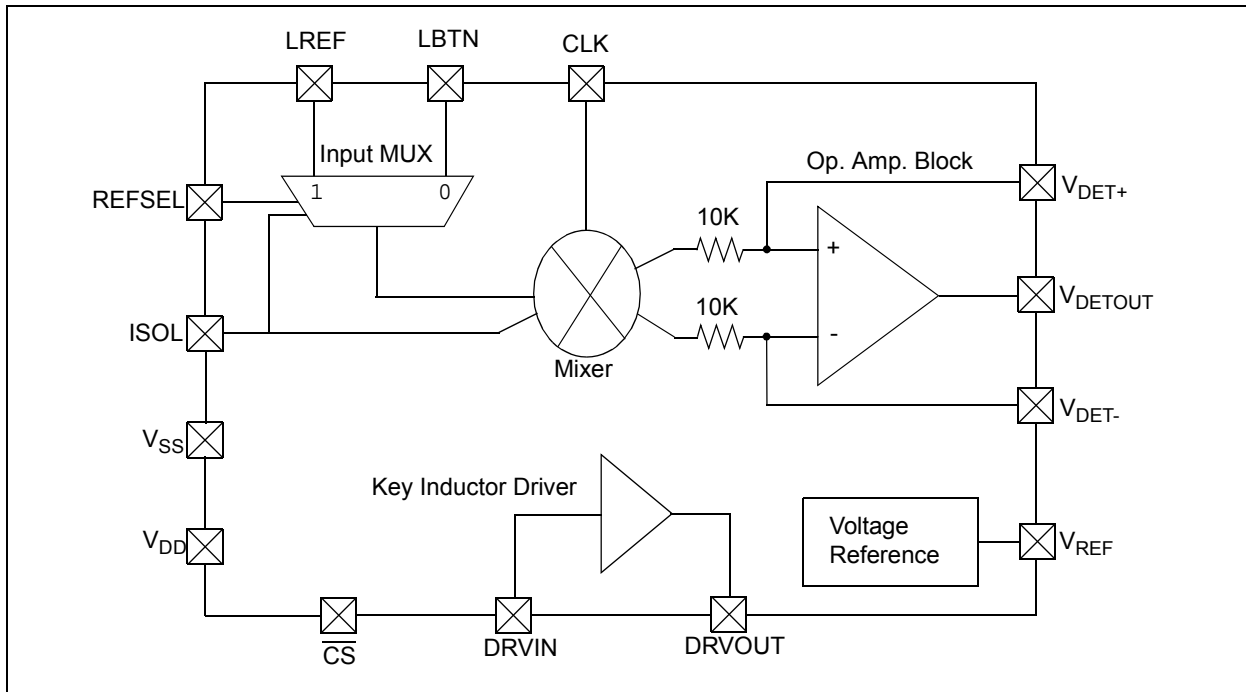

FIGURE 1-1: MCP2036 Block Diagram

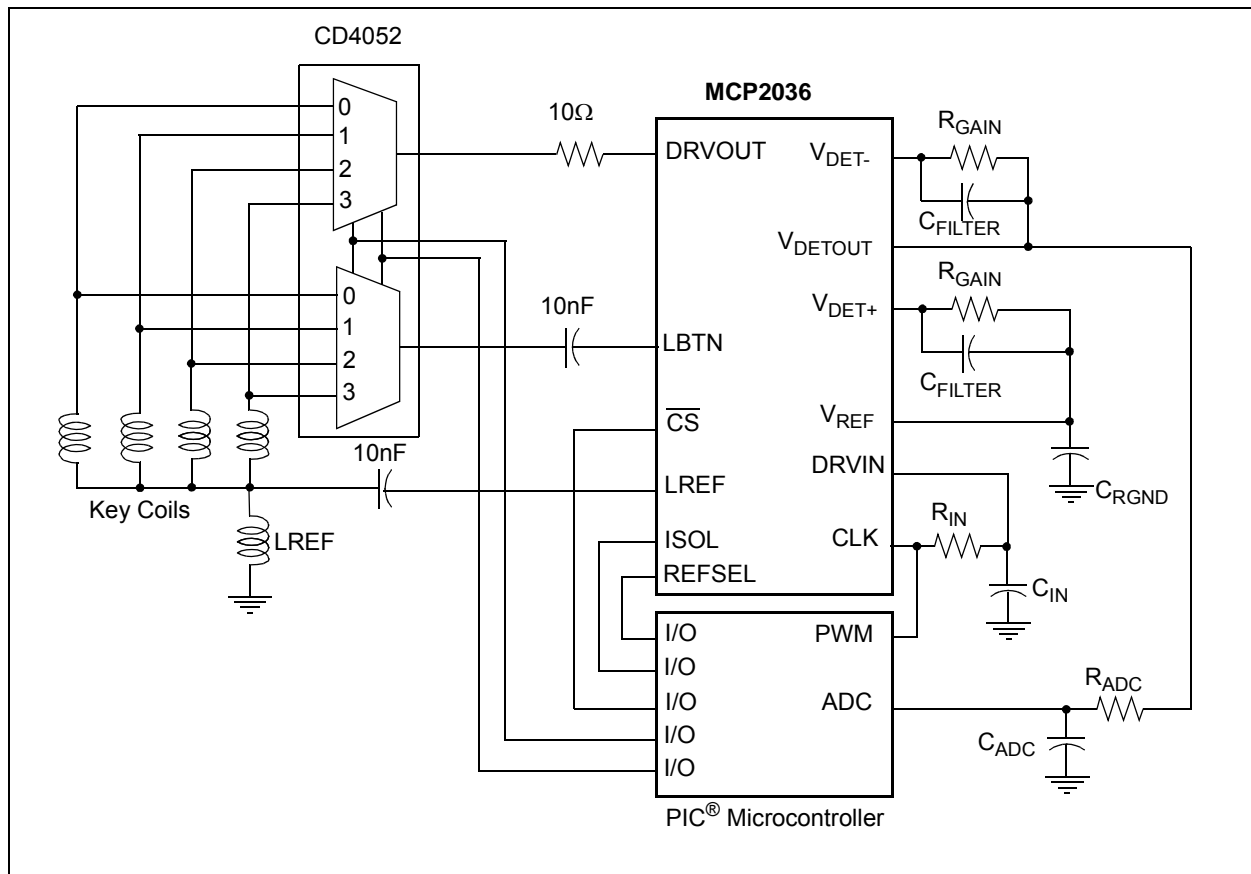

FIGURE 1-2: MCP2036 Typical Application

The coil voltages are then multiplexed into the Synchronous Detector section by the LBTN/LREF multiplexer. This allows the microcontroller to select which signal is sampled by the detector. The detector converts the coil voltages into a DC level using a frequency mixer, amplifier, and filter.

The mixer is composed of two switches driven by the clock present on the CLK signal input. The switches toggle the amplifier/filter between an inverting and non-inverting topology, at a rate equal to the clock input frequency. This inverts and amplifies the negative side of the signal, while amplifying the positive side. The result is a pulsed DC signal with a peak voltage, proportional to the amplitude of the AC coil voltage.

The gain of the detector is set by two pairs of resistors; one pair are the internal fixed series resistors between the frequency mixer and the amplifier. The second resistor pair are the two external gain set resistors (R_{GAIN}). The two capacitors (C_{FILTER}) in parallel with the external gain setting resistors form a low pass filter which converts the pulsed DC output signal into a smooth DC voltage which is proportional to the AC sensor voltage input. The output of the system is present on the V_{DETOUT} pin, which drives the microcontroller's ADC input for conversion into a digital value.

The virtual ground reference for the detector/amplifier is generated by a second internal op amp which produces a virtual ground equal to $\frac{1}{2}$ the supply voltage. The virtual ground is available externally at the V_{REF} output and used internally throughout the detector circuit, allowing single supply operation. A small external capacitance is required to stabilize this output and limit noise.

The ISOL input is used to isolate the detector from potential noise sources during the measurement of the virtual ground reference during a button measurement.

MCP2036

1.1 Coil Driver

The coil driver produces the excitation current for the sensor coils.

The coil driver input is derived from the digital clock supplied to the CLK input. The digital signal is first filtered through a low-pass filter, composed of R_{IN} and C_{IN} , and passed to the DRVIN input. The driver will create a triangular current in phase and proportional with the input voltage. Because the digital drive into the R_{IN} - C_{IN} filter has a 50% duty cycle, the voltage on the DRVIN input will be centered at $V_{DD}/2$. The relationship between voltage, current, inductance and frequency is shown in [Equation 1-1](#).

EQUATION 1-1:

$$\Delta V_{OUT} = (\Delta I_{DRV} \cdot L_{COIL} \cdot 2 \cdot F_{DRV})$$

V_{OUT} = Pulsed Output Voltage

ΔI_{DRV} = AC Drive Current Amplitude

F_{DRV} = AC Drive Current Frequency

L_{COIL} = Inductance of the Sensor Coil

Note: These equations assume a 50% duty cycle.

1.2 Synchronous Detector and Output Amplifier

The Synchronous Detector has two inputs, LREF and LBTN, selectable by REFSEL. This routes either signal into the frequency mixer of the detector. The frequency mixer then converts the AC waveform into a pulsed DC signal which is amplified and filtered.

The gain of the amplifier is user-settable, using an external resistor, R_{GAIN} (see [Equation 1-2](#)).

EQUATION 1-2:

$$Gain \sim R_{GAIN} / 10k\Omega$$

An ADC plus firmware algorithm then digitizes the detector output voltage and uses the resulting data to detect a key press event.

Note: The output amplifier/filter uses a differential connection, so its output is centered to V_{REF} ($V_{DD}/2$). The amplitude of the detected signal should be calculated as the difference between voltages at the output of the detector and the reference voltage.

1.3 Virtual Ground Voltage Reference Circuit

To create both an inverting and non-inverting amplifier topology, a pseudo split supply design is required. To generate the dual supplies required, a rail splitter is included, which generates the virtual ground by creating a voltage output at $V_{DD}/2$. The output is used by the external passive network of the Detector/Amplifier section as a reference on the non-inverting input. A bypass capacitor of 0.1 μF is required to ensure the stability of the output. For reference accuracy, no more than 3 mA should be supplied to, or drawn from the reference output pin.

2.0 PIN DESCRIPTION

Descriptions of the pins are listed in [Table 2-1](#).

TABLE 2-1: PIN FUNCTION TABLE

Pad Name	Pin Number		I/O	Type	Description
	14 Pins	16 Pins			
V _{REF}	1	16	OUT	AN	Voltage Reference
LREF	2	1	IN	AN	Reference Inductor Input
LBTN	3	2	IN	AN	Active Inductor Input
V _{DD}	4	3	PWR	AN	Power Supply
DRVOUT	5	4	OUT	AN	Current Driver Output for Inductors
DRVIN	6	5	IN	AN	Current Driver Input
CLK	7	6	IN	CMOS	Clock Signal
REFSEL	8	7	IN	CMOS	Detector Select Input
$\overline{\text{CS}}$	9	8	IN	CMOS	Chip Select, Active low
ISOL	10	9	IN	CMOS	Detector Isolation Control Input, high = isolate
V _{SS}	11	10	PWR	AN	Power Supply Return
V _{DETOU}	12	11	OUT	AN	Detector Output Voltage
V _{DET-}	13	12	IN	AN	Negative Input for Output Detector
V _{DET+}	14	13	IN	AN	Positive Input for Output Detector
NC		14	—	—	No connect
NC		15	—	—	No connect

2.1 Chip Select ($\overline{\text{CS}}$)

The circuit is fully enabled when a logic-low is applied to the $\overline{\text{CS}}$ input. The circuit enters in Low-Power mode when a logic-high is applied to this input. During Low-Power mode, the detector output voltage falls to V_{REF} and the supply current is reduced to 0.5 μA (typ.).

This pin has an internal pull-up resistor to ensure proper selection of the circuit.

2.2 Voltage Reference (V_{REF})

V_{REF} is a mid-scale reference output. It can source and sink small currents and has low output impedance. A load capacitor between 100 nF and 1 μF needs to be located close to this pin.

2.3 Power Supply (V_{DD}, V_{SS})

The V_{DD} pin is the power supply pin for the analog and digital circuitry within the MCP2036. This pin requires an appropriate bypass capacitor of 100 nF. The voltage on this pin should be maintained in the 2.7V-5.5V range for specified operation.

The V_{SS} pin is the ground pin and the current return path for both analog and digital circuitry of the MCP2036. If an analog ground plane is available, it is recommended that this device be tied to the analog ground plane of the PCB.

2.4 Inductor Inputs (LREF, LBTN)

These pins are inputs for the external coils (reference and sensor). The inputs should be AC coupled to the coils by a 10 nF ceramic capacitor.

2.5 Input Selection (REFSEL)

Digital input that is used to select between coil inputs (reference and sensor).

2.6 Detector Isolate (ISOL)

Digital input that is used to isolate the detector circuit while measuring the system virtual ground. Pulling the input high disables the detector input multiplexers, isolating the op amp circuitry from the coils inputs. Pulling the input low reconnects the inputs for measuring both reference and button coil inputs.

2.7 Clock (CLK)

The external clock input is used for synchronous detection of the AC waveforms on the coils. The clock signal is also used to generate a triangular waveform applied to coil driver input.

MCP2036

2.8 Inductor Driver Input (DRVIN)

The analog input to the coil driver. The triangular waveform applied to this input should be in phase with the clock signal for best performance.

2.9 Inductor Driver Output (DRVOUT)

Driver output used to excite the sensor coils. It is a current-mode output designed to drive small inductive loads.

2.10 Detector Output Voltage (V_{DETOUT})

The amplifier/filter output from the detector. This is a low-impedance analog output pin (V_{OUT}) for driving the microcontroller ADC. The detector output is rail-to-rail.

2.11 Inputs for Output Detector (V_{DET+} , V_{DET-})

The non-inverting and inverting inputs for the amplifier/filter op amp. The two inputs are connected to the output of the mixer circuit through two internal $10K\Omega$ resistors.

3.0 APPLICATIONS

The MCP2036 is an Analog Front End device that uses the electromagnetic interaction between a conductive target and a sensing coil to detect the pressure applied by the user on the surface of a touch panel. The device incorporates all analog blocks for a simple inductor impedance measurement circuit.

For an inductive touch system, two methods are used for switching the driver and measurement circuitry between the different sensor coils: analog multiplexers and GPIO grounding (see [Figure 3-1](#) and [Figure 3-2](#)). The MCP2036 is designed to work with both configurations:

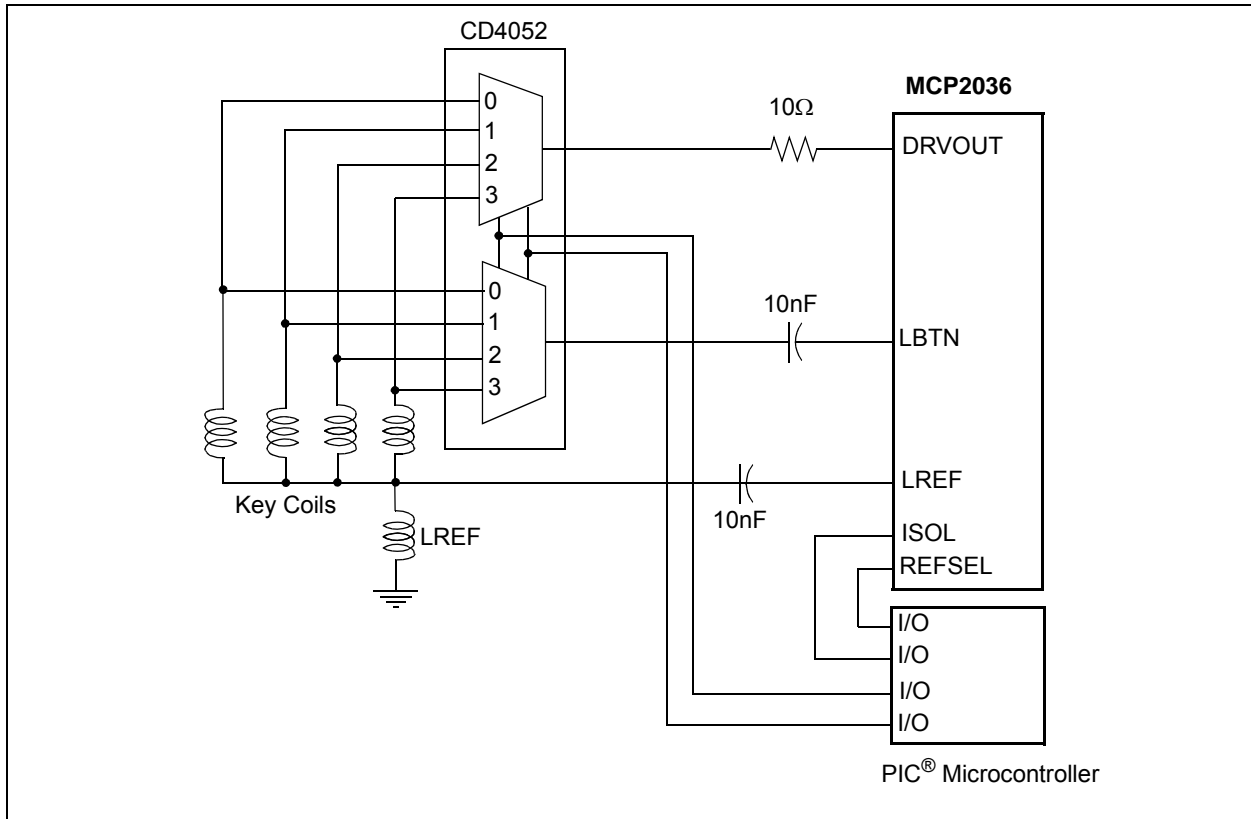

FIGURE 3-1: Using Analog-Multiplexer for Key Selection (Example)

MCP2036

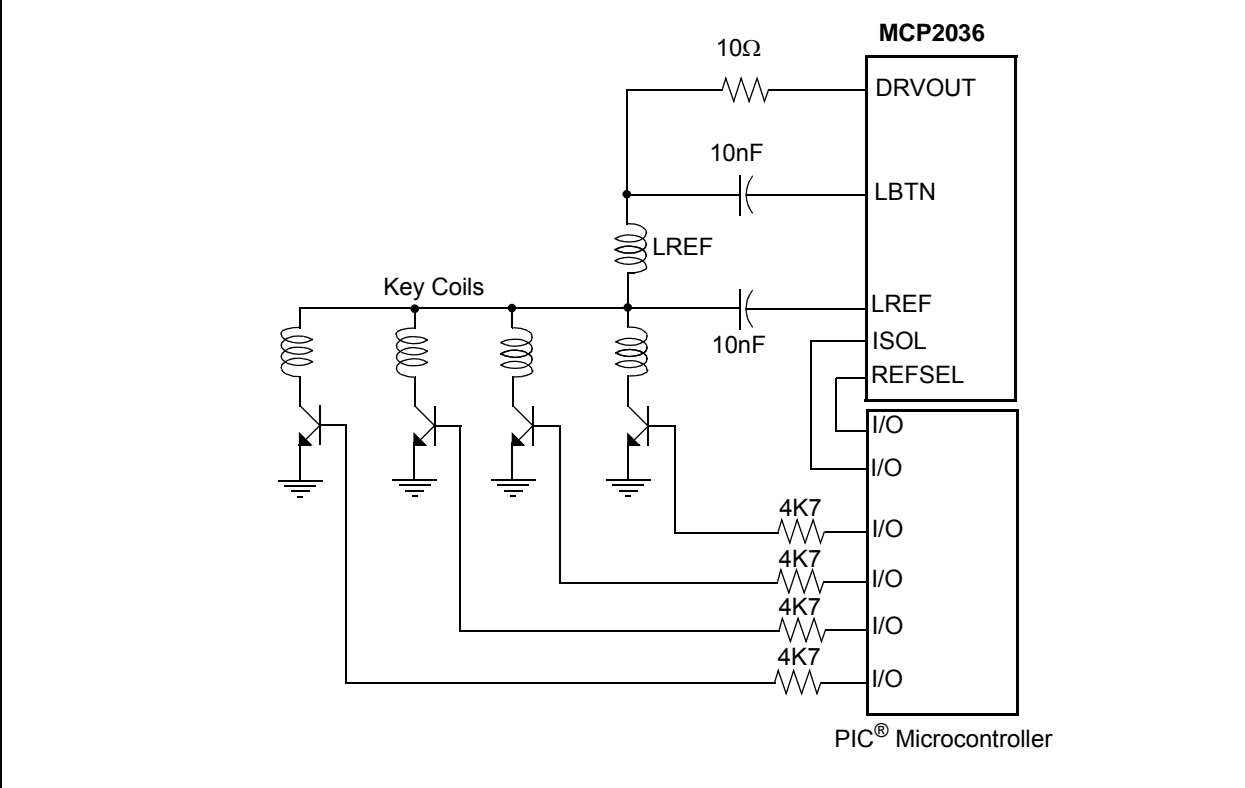

FIGURE 3-2: Using NPN transistors for Key Selection (Example)

MCP2036

Substituting in the equation for an RC network:

EQUATION 3-4:

$$2\Delta V = (V_{DD}/2 + \Delta V) \cdot [1 - \exp(-t/RC)]$$

$$\Delta V = \frac{V_{DD}}{2} \cdot \frac{1 - \exp\left(\frac{-t}{R_{IN}C_{IN}}\right)}{1 + \exp\left(\frac{-t}{R_{IN}C_{IN}}\right)}$$

The peak-to-peak amplitude of the resulting triangular waveform, at the coil driver input, is shown in Equation 3-5:

EQUATION 3-5:

$$V_{PKPK} = 2\Delta V$$

$$V_{PKPK} = V_{DD} \cdot \frac{1 - \exp\left(\frac{-t}{R_{IN}C_{IN}}\right)}{1 + \exp\left(\frac{-t}{R_{IN}C_{IN}}\right)}$$

Note: V_{PKPK} should not exceed specified value (600mV) for best performance.

From the previous equation, the designer should choose values for V_{PKPK} and R_{IN} . Using the equation above, the value of C_{IN} will be:

EQUATION 3-6:

$$C_{IN} = \frac{t}{R_{IN} \cdot \ln\left(\frac{V_{DD} - V_{PKPK}}{V_{DD} + V_{PKPK}}\right)} = \frac{1}{2 \cdot F \cdot R_{IN} \cdot \ln\left(\frac{V_{DD} - V_{PKPK}}{V_{DD} + V_{PKPK}}\right)}$$

Note: Assuming a power supply of 5V and $V_{PKPK}=500\text{mV}$, for $R_{IN}=3.9\text{K}\Omega$, C_{IN} should have about 320pF. A 330pF capacitor will be used.

The amplitude of the pulsed current applied to key inductors will be:

EQUATION 3-7:

$$\Delta I = V_{PKPK} \cdot G_{DRV}$$

G_{DRV} - Gain of Coil Driver

This current produces a pulsed voltage to key inductors ends. The amplitude of this voltage will be:

EQUATION 3-8:

$$\Delta U = L \cdot \frac{\Delta I}{\Delta t} = L \cdot V_{PKPK} \cdot G_{DRV} \cdot 2F$$

F - PWM Frequency
 L - Inductance of Key Inductor

Note: For a PWM frequency of 2 MHz and inductor value of 2.7μH, the amplitude of pulsed voltage will be:
 $\Delta U = 10.8\text{mV}$

The total voltage across both the reference and sensor coils would be double (two series inductors). For a specific power supply voltage, half of this power supply, relative to the voltage reference, is available for output amplifier/detector. Assuming a 30% margin, the desired gain for the detector should be about:

EQUATION 3-9:

$$\text{Gain} = \frac{70\% \cdot \left(\frac{V_{DD}}{2}\right)}{2 \cdot \Delta U}$$

The gain of the amplifier is user-settable, using an external resistor, R_{GAIN} . The value of that resistor will be determined using the following equation:

EQUATION 3-10:

$$\text{Gain} \sim R_{GAIN}/10\text{kOhm}$$

With a 10-bit ADC, using oversampling and averaging techniques, the effective resolution is close to 11 bits. As shown in AN1239, "Inductive Touch Sensor Design", the typical shift in sensor impedance is typically 3-4%, so the actual number of counts per press is typically between 20 and 40 counts. In this way, the microcontroller firmware could easily detect press event.

Note: For a power supply of 5V and $\Delta U = 10\text{mV}$, the resulted gain is 81. To obtain this gain, $R_{GAIN} = 820\text{kOhm}$ should be used.

4.0 ELECTRICAL CHARACTERISTICS

4.1 Absolute Maximum Ratings

Ambient temperature under bias.....	-40°C to +125°C
Storage temperature.....	-65°C to +150°C
Voltage on V _{DD} with respect to V _{SS}	-0.3V to +6.5V
Analog Inputs (V _{DET+} , V _{DET-}).....	V _{SS} -1.0V to V _{DD} +1.0V
Voltage on all other pins with respect to V _{SS}	-0.3V to (V _{DD} + 0.3V)
Current at Output and Supply Pins.....	±30 mA
Human Body ESD Rating.....	2000 V
Machine Model ESD Rating	200 V
Maximum Junction Temperature	+150°C

4.2 Specifications

TABLE 4-1: DC CHARACTERISTICS

Electrical Specifications: Unless otherwise indicated, T _A = +25°C, V _{DD} = +2.7V to +5.5V, V _{SS} = GND.						
Parameters	Sym.	Min.	Typ.	Max.	Units	Conditions
General Device Parameters						
Supply Voltage	V _{DD}	2.7	—	5.5	V	
Power-Down Current	I _{PD}	—	12	—	nA	$\overline{CS} = 1, V_{DD} = +2.7V, \text{(Note 1)}$
	I _{PD}	—	25	—	nA	$\overline{CS} = 1, V_{DD} = +5.5V, \text{(Note 1)}$
Quiescent Current	I _{DD}	—	2	—	mA	V _{DD} = +2.7V, DRVIN = 0V, CLK = Low
	I _{DD}	—	3.7	—	mA	V _{DD} = +5.5V, DRVIN = 0V, CLK = Low
Active Current	I _{DD}	—	3.4	—	mA	V _{DD} = +2.7V, CLK = 2 MHz
	I _{DD}	—	6.8	—	mA	V _{DD} = +5.5V, CLK = 2 MHz
Digital IO Parameters						
Digital Input High Voltage	V _{IH}	0.7V _{DD}	—	—	V	
Digital Input Low Voltage	V _{IL}	—	—	0.3V _{DD}	V	
Input Pins Leakage Current	I _{LKG}	—	—	±100	nA	$\overline{CS}, CLK, REFSEL, LREF, LBTN$
Output Amplifier/Filter Specific Parameters						
System Parameters						
DC Open Loop Gain	A _{OL}	90	110	—	dB	
Power Supply Rejection Ratio	PSRR	—	86	—	dB	
Common Mode Rejection Ratio	CMMR	60	76	—	dB	
Amplifier Input Characteristics						
Input Offset Voltage	V _{OS}	—	—	±7	mV	
Input Bias Current	I _B	—	—	±20	pA	(Note 1)
	—	—	—	±1	nA	(Note 1)
Input Offset Current	I _{OS}	—	—	±1	pA	(Note 1)
Input Impedance	Z _{IN}	—	10 ¹³ 6	—	Ω pF	Common mode impedance
	—	—	10 ¹³ 6	—	Ω pF	Differential impedance
Amplifier Output Characteristics						
Minimum Output Voltage	V _{OMIN}	V _{SS} +20	—	—	mV	
Maximum Output Voltage	V _{OMAX}	—	—	V _{DD} -20	mV	

MCP2036

TABLE 4-1: DC CHARACTERISTICS (CONTINUED)

Electrical Specifications: Unless otherwise indicated, $T_A = +25^\circ\text{C}$, $V_{DD} = +2.7\text{V}$ to $+5.5\text{V}$, $V_{SS} = \text{GND}$.						
Parameters	Sym.	Min.	Typ.	Max.	Units	Conditions
Short Circuit Current	I_{SC}	—	± 6	—	mA	V_{DETOUT} , $V_{DD} = 3\text{V}$
	—	—	± 10	—	mA	V_{DETOUT} , $V_{DD} = 5\text{V}$
Voltage Reference Specific Parameters						
Output Voltage	V_{REF}	—	$V_{DD}/2$	—	mV	
Output Short Circuit Current	I_{SC}	—	6	—	mA	$V_{DD} = 3\text{V}$
	—	—	10	—	mA	$V_{DD} = 5\text{V}$
Maximum Output Capacitance	C_{OUT}	—	—	1	μF	(Note 1)
Series Output Resistance	R_{SER}	—	250	—	Ω	Internal resistor used to stabilize op amp output for pure capacitive loads
Coil Driver Specific Parameters						
System Parameters						
Amplifier Current Gain	A_{OL}	—	3	—	mA/V	$V_{DD} = +2.7\text{V}$
	A_{OL}	—	3.6	—	mA/V	$V_{DD} = +5.5\text{V}$
Power Supply Rejection Ratio	PSRR	60	—	—	dB	
Input Characteristics						
Input Voltage Range	V_{MAX}	$V_{DD}/2 - 300$	—	$V_{DD}/2 + 300$	mV	$V_{DD} = 5\text{V}$
Input Bias/Leakage Current	I_B	—	—	± 20	pA	$T = 85^\circ\text{C}$ (Note 1)
	I_B	—	—	± 1	nA	$T = 125^\circ\text{C}$ (Note 1)
Input Impedance	Z_{IN}	—	$10^{13} 6$	—	$\Omega \mu\text{F}$	Common mode impedance
	—	—	$10^{13} 6$	—	$\Omega \mu\text{F}$	Differential impedance
Output Characteristics						
Minimum Output Voltage	V_{OMIN}	$V_{SS} + 20$	—	—	mV	
Maximum Output Voltage	V_{OMAX}	—	—	$V_{DD} - 20$	mV	
Short Circuit Current	I_{SC}	—	± 6	—	mA	DRVOUT, $V_{DD} = 3\text{V}$
	I_{SC}	—	± 10	—	mA	DRVOUT, $V_{DD} = 5\text{V}$
Resistor Specifications						
Resistance Value of R1	R1	—	8	—	$\text{K}\Omega$	Resistor between pass gates and output amplifier input
Resistance Value of R2	R2	—	2	—	$\text{K}\Omega$	Resistor between LBTN and LREF inputs and voltage reference

TABLE 4-2: AC CHARACTERISTICS

Electrical Characteristics: Unless otherwise indicated, $V_{DD} = +2.7\text{V}$ to $+5.5\text{V}$, and $V_{SS} = \text{GND}$.						
Parameters	Sym.	Min.	Typ.	Max.	Units	Conditions
Output Amplifier/Filter Specific Parameters						
Gain Bandwidth Product	GBWP	—	1	—	MHz	
Slew Rate	SR	—	0.6	—	$\text{V}/\mu\text{s}$	
Coil Driver Amplifier Parameters						
Gain Bandwidth Product	GBWP	—	17.8	—	MHz	
Voltage Reference Specific Parameters						
Gain Bandwidth Product	GBWP	—	1	—	MHz	
Slew Rate	SR	—	0.6	—	$\text{V}/\mu\text{s}$	

TABLE 4-3: TEMPERATURE SPECIFICATIONS

Electrical Characteristics: Unless otherwise indicated, $V_{DD} = +2.7V$ to $+5.5V$, and $V_{SS} = GND$.						
Parameters	Sym.	Min.	Typ.	Max.	Units	Conditions
Temperature Ranges						
Industrial Temperature Range	T_A	-40	—	+85	$^{\circ}C$	
Extended Temperature Range	T_A	-40	—	+125	$^{\circ}C$	
Operating Temperature Range	T_A	-40	—	+125	$^{\circ}C$	
Storage Temperature Range	T_A	-65	—	+150	$^{\circ}C$	
Thermal Package Resistances						
Thermal Resistance, 14L-PDIP	θ_{JA}	—	70	—	$^{\circ}C/W$	
Thermal Resistance, 14L-SOIC	θ_{JA}	—	120	—	$^{\circ}C/W$	
Thermal Resistance, 16L-QFN	θ_{JA}	—	47	—	$^{\circ}C/W$	

TABLE 4-4: TIMING DIAGRAM

Electrical Characteristics: Unless otherwise indicated, $V_{DD} = +2.7V$ to $+5.5V$, and $V_{SS} = GND$.						
Parameters	Sym.	Min.	Typ.	Max.	Units	Conditions
Input Clock Frequency	F_{CLK}	—	2	—	MHz	
Duty Factor	D	—	50	—	%	
Device Turn-On Time	t_{ON}	—	4	10	μs	Time from $\overline{CS} = 0$ to valid V_{DETOUT} output (Note 1)
Device Power-Down Time	t_{OFF}	—	1—	—	μs	Time from $\overline{CS} = 1$ to High-Z outputs on all drivers (Note 1)

Note 1: Not tested in production but it is characterized.

MCP2036

NOTES:

5.0 TYPICAL PERFORMANCE CURVES

5.1 Performance Plots



FIGURE 5-1: Driver Input Waveforms

MCP2036

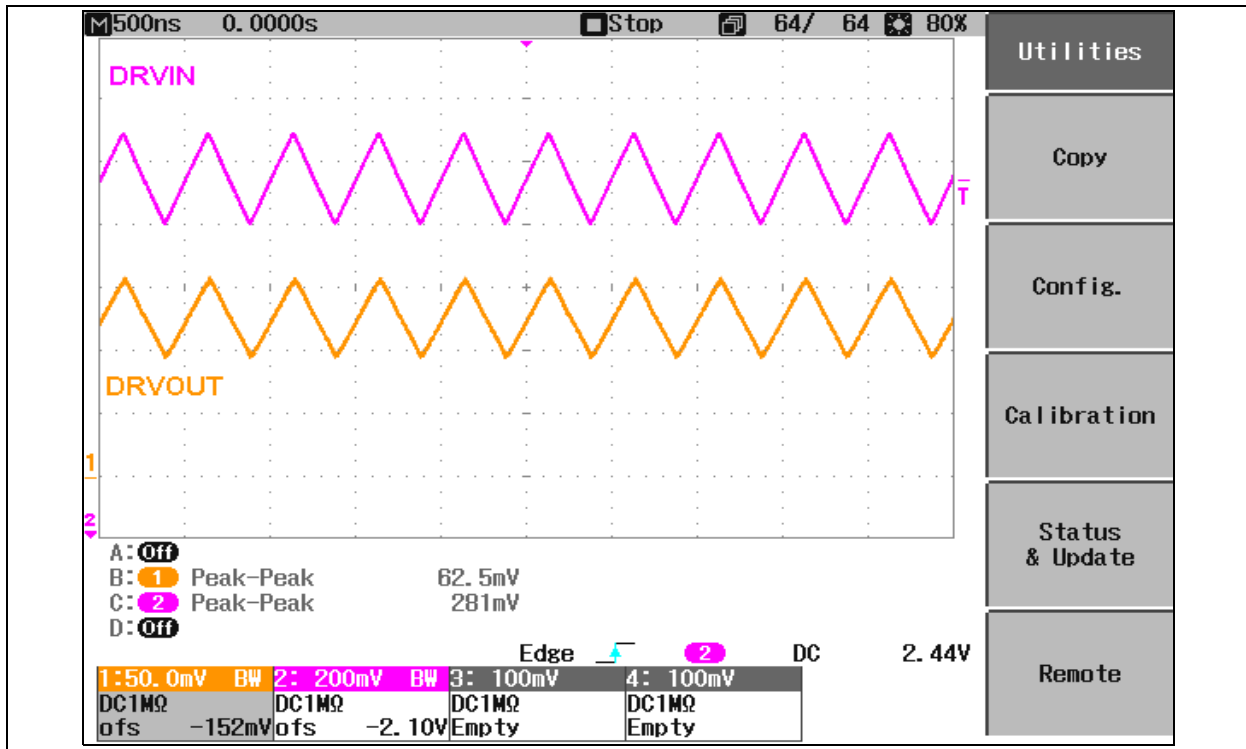

FIGURE 5-2: Inductor Driver Transfer Function ($R_{load} = 100 \text{ Ohm}$)



FIGURE 5-3: Pulsed Voltage on Active Key Inductor (I/O Configuration)



FIGURE 5-4: Pulsed voltage on Reference Inductor Series with Active Inductor

MCP2036

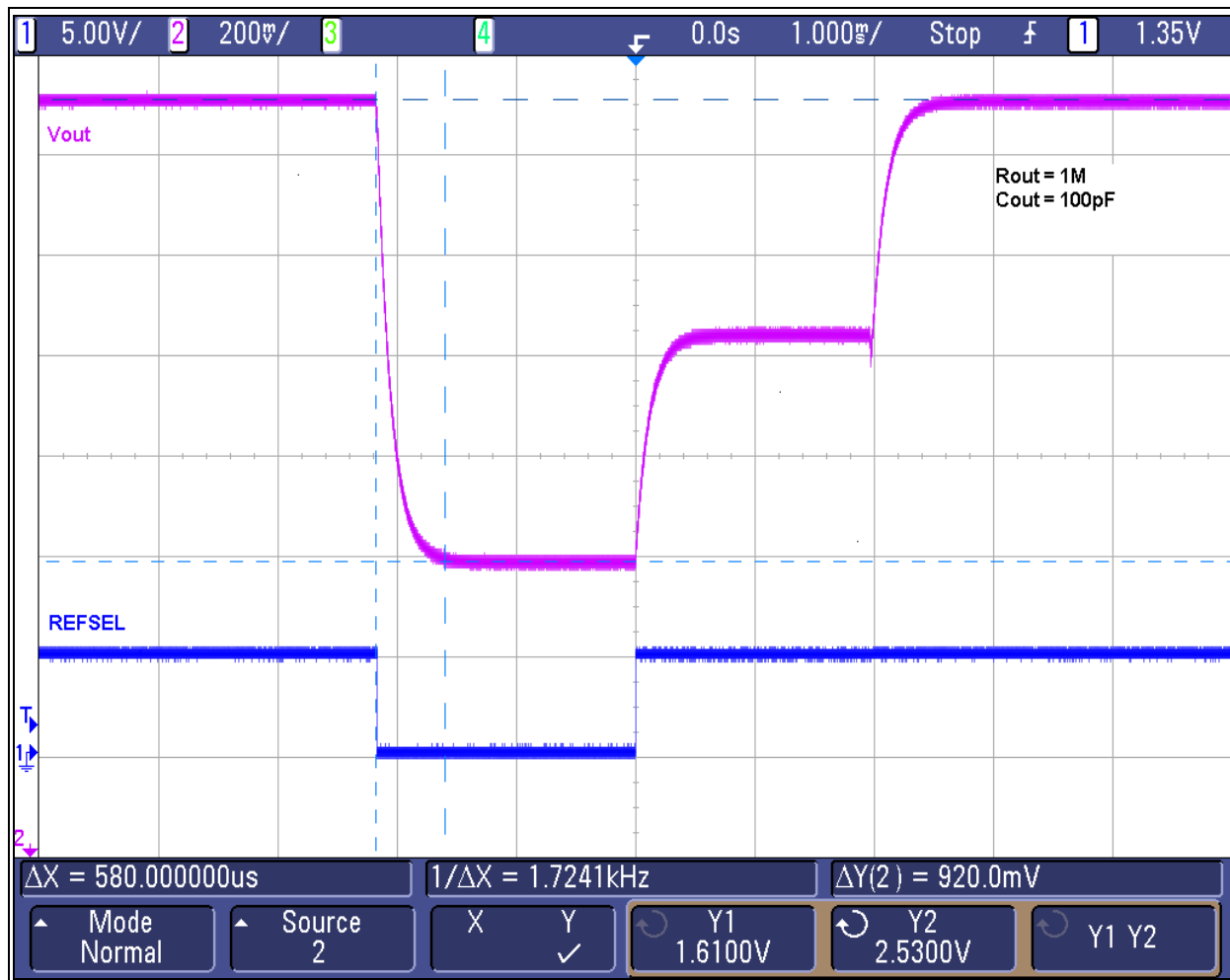
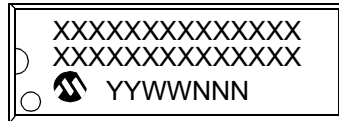

FIGURE 5-5: Output Detector Response Time

6.0 PACKAGING INFORMATION

6.1 Package Marking Information

14-Lead PDIP



Example

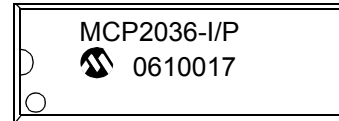

14-Lead SOIC (.150")



Example

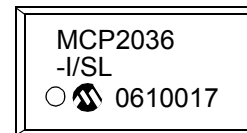

16-Lead QFN

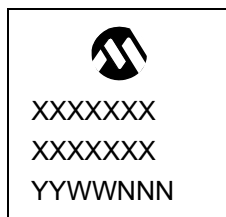

Example

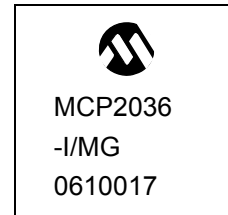

Legend:	XX...X	Customer-specific information
	Y	Year code (last digit of calendar year)
	YY	Year code (last 2 digits of calendar year)
	WW	Week code (week of January 1 is week '01')
	NNN	Alphanumeric traceability code
	(e3)	Pb-free JEDEC designator for Matte Tin (Sn)
	*	This package is Pb-free. The Pb-free JEDEC designator (e3) can be found on the outer packaging for this package.

Note: In the event the full Microchip part number cannot be marked on one line, it will be carried over to the next line, thus limiting the number of available characters for customer-specific information.

MCP2036

6.2 Package Details

The following sections give the technical details of the packages.

14-Lead Plastic Dual In-Line (P) – 300 mil Body [PDIP]

Note: For the most current package drawings, please see the Microchip Packaging Specification located at <http://www.microchip.com/packaging>

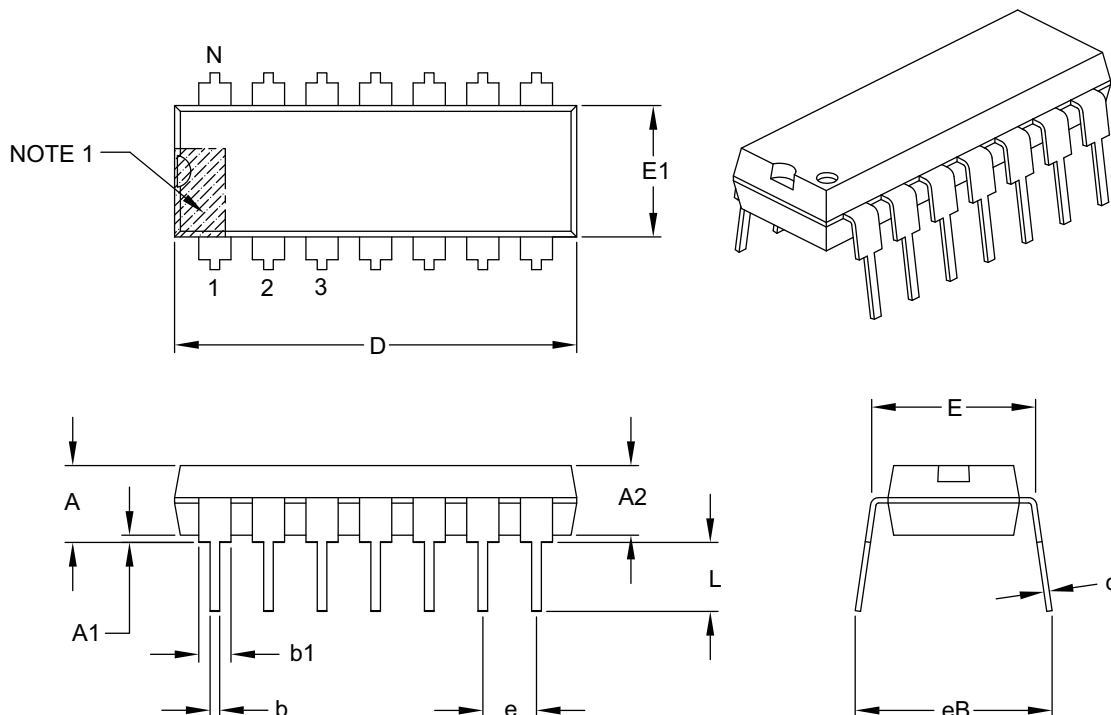

Dimension Limits	Units	INCHES		
		MIN	NOM	MAX
Number of Pins	N	14		
Pitch	e	.100 BSC		
Top to Seating Plane	A	–	–	.210
Molded Package Thickness	A2	.115	.130	.195
Base to Seating Plane	A1	.015	–	–
Shoulder to Shoulder Width	E	.290	.310	.325
Molded Package Width	E1	.240	.250	.280
Overall Length	D	.735	.750	.775
Tip to Seating Plane	L	.115	.130	.150
Lead Thickness	c	.008	.010	.015
Upper Lead Width	b1	.045	.060	.070
Lower Lead Width	b	.014	.018	.022
Overall Row Spacing §	eB	–	–	.430

Notes:

1. Pin 1 visual index feature may vary, but must be located with the hatched area.
2. § Significant Characteristic.
3. Dimensions D and E1 do not include mold flash or protrusions. Mold flash or protrusions shall not exceed .010" per side.
4. Dimensioning and tolerancing per ASME Y14.5M.

BSC: Basic Dimension. Theoretically exact value shown without tolerances.

Microchip Technology Drawing C04-005B

14-Lead Plastic Small Outline (SL) – Narrow, 3.90 mm Body [SOIC]

Note: For the most current package drawings, please see the Microchip Packaging Specification located at <http://www.microchip.com/packaging>



Dimension Limits	Units	MILLIMETERS		
		MIN	NOM	MAX
Number of Pins	N	14		
Pitch	e	1.27 BSC		
Overall Height	A	–	–	1.75
Molded Package Thickness	A2	1.25	–	–
Standoff §	A1	0.10	–	0.25
Overall Width	E	6.00 BSC		
Molded Package Width	E1	3.90 BSC		
Overall Length	D	8.65 BSC		
Chamfer (optional)	h	0.25	–	0.50
Foot Length	L	0.40	–	1.27
Footprint	L1	1.04 REF		
Foot Angle	ϕ	0°	–	8°
Lead Thickness	c	0.17	–	0.25
Lead Width	b	0.31	–	0.51
Mold Draft Angle Top	α	5°	–	15°
Mold Draft Angle Bottom	β	5°	–	15°

Notes:

- Pin 1 visual index feature may vary, but must be located within the hatched area.
- § Significant Characteristic.
- Dimensions D and E1 do not include mold flash or protrusions. Mold flash or protrusions shall not exceed 0.15 mm per side.
- Dimensioning and tolerancing per ASME Y14.5M.

BSC: Basic Dimension. Theoretically exact value shown without tolerances.

REF: Reference Dimension, usually without tolerance, for information purposes only.

Microchip Technology Drawing C04-065B

MCP2036

14-Lead Plastic Small Outline (SL) - Narrow, 3.90 mm Body [SOIC]

Note: For the most current package drawings, please see the Microchip Packaging Specification located at <http://www.microchip.com/packaging>

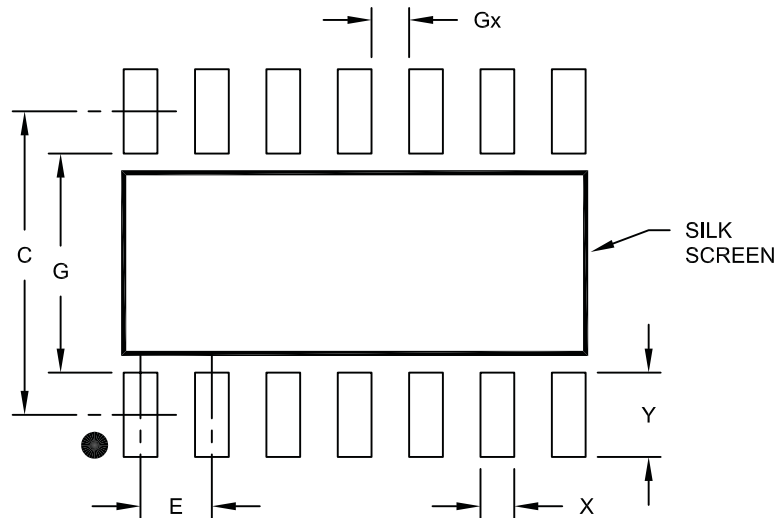

RECOMMENDED LAND PATTERN

Dimension Limits	Units	MILLIMETERS		
		MIN	NOM	MAX
Contact Pitch	E	1.27 BSC		
Contact Pad Spacing	C		5.40	
Contact Pad Width	X			0.60
Contact Pad Length	Y			1.50
Distance Between Pads	Gx	0.67		
Distance Between Pads	G	3.90		

Notes:

1. Dimensioning and tolerancing per ASME Y14.5M

BSC: Basic Dimension. Theoretically exact value shown without tolerances.

Microchip Technology Drawing No. C04-2065A

16-Lead Plastic Quad Flat, No Lead Package (MG) - 3x3x0.9 mm Body [QFN]

Note: For the most current package drawings, please see the Microchip Packaging Specification located at <http://www.microchip.com/packaging>

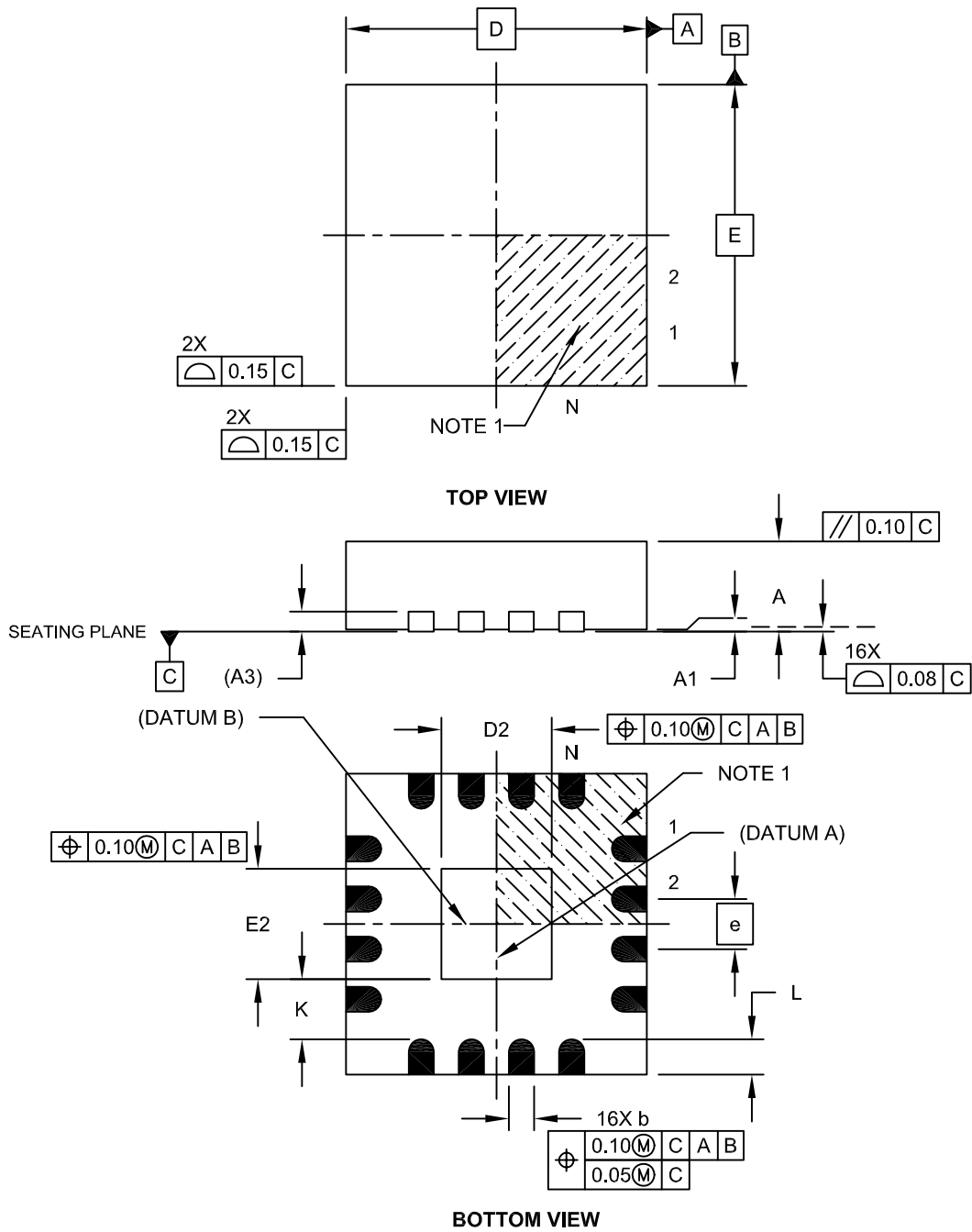

Microchip Technology Drawing C04-142A Sheet 1 of 2

MCP2036

16-Lead Plastic Quad Flat, No Lead Package (MG) - 3x3x0.9 mm Body [QFN]

Note: For the most current package drawings, please see the Microchip Packaging Specification located at <http://www.microchip.com/packaging>



Dimension Limits	Units	MILLIMETERS		
		MIN	NOM	MAX
Number of Pins	N	16		
Pitch	e	0.50 BSC		
Overall Height	A	0.80	0.85	0.90
Standoff	A1	0.00	0.02	0.05
Contact Thickness	A3	0.20 REF		
Overall Width	E	3.00 BSC		
Exposed Pad Width	E2	1.00	1.10	1.50
Overall Length	D	3.00 BSC		
Exposed Pad Length	D2	1.00	1.10	1.50
Contact Width	b	0.18	0.25	0.30
Contact Length	L	0.25	0.35	0.45
Contact-to-Exposed Pad	K	0.20	-	-

Notes:

1. Pin 1 visual index feature may vary, but must be located within the hatched area.
2. Package is saw singulated.
3. Dimensioning and tolerancing per ASME Y14.5M.
BSC: Basic Dimension. Theoretically exact value shown without tolerances.
REF: Reference Dimension, usually without tolerance, for information purposes only.

Microchip Technology Drawing C04-142A Sheet 2 of 2

APPENDIX A: REVISION HISTORY

Revision A (05/2009)

Original release of the document.

Revision B (09/2009)

Replaced the 4X4 QFN Package with the 3X3 QFN Package; Replaced ML with MG in the 16-Lead QFN Example; Added SOIC (SL) Land Pattern.

Revision C (11/2009)

Updated the Package Types, adding ISOL; Updated Figures 1-1, 1-2 and Table 2-1; Added Section 2-6 (Detector Isolate); Updated Figures 3-1, 3-2 and 3-3; Other minor edits.

MCP2036

NOTES:

PRODUCT IDENTIFICATION SYSTEM

To order or obtain information, e.g., on pricing or delivery, refer to the factory or the listed sales office.

<u>PART NO.</u>	<u>X</u>	<u>/XX</u>	<u>XXX</u>
Device	Temperature Range	Package	Pattern
Device:	MCP2036 VDD range 2.7V to 5.5V		
Temperature Range:	I = -40°C to+85°C (Industrial) E = -40°C to+125°C(Extended)		
Package:	MG = QFN SL = SOIC P = PDIP		
Pattern:	QTP, SQTP, Code or Special Requirements (blank otherwise)		

Examples:
MCP2036-I/P 301 = Industrial temp., PDIP package, QTP pattern #301.

MCP2036

NOTES:

Note the following details of the code protection feature on Microchip devices:

- Microchip products meet the specification contained in their particular Microchip Data Sheet.
- Microchip believes that its family of products is one of the most secure families of its kind on the market today, when used in the intended manner and under normal conditions.
- There are dishonest and possibly illegal methods used to breach the code protection feature. All of these methods, to our knowledge, require using the Microchip products in a manner outside the operating specifications contained in Microchip's Data Sheets. Most likely, the person doing so is engaged in theft of intellectual property.
- Microchip is willing to work with the customer who is concerned about the integrity of their code.
- Neither Microchip nor any other semiconductor manufacturer can guarantee the security of their code. Code protection does not mean that we are guaranteeing the product as “unbreakable.”

Code protection is constantly evolving. We at Microchip are committed to continuously improving the code protection features of our products. Attempts to break Microchip's code protection feature may be a violation of the Digital Millennium Copyright Act. If such acts allow unauthorized access to your software or other copyrighted work, you may have a right to sue for relief under that Act.

Information contained in this publication regarding device applications and the like is provided only for your convenience and may be superseded by updates. It is your responsibility to ensure that your application meets with your specifications. MICROCHIP MAKES NO REPRESENTATIONS OR WARRANTIES OF ANY KIND WHETHER EXPRESS OR IMPLIED, WRITTEN OR ORAL, STATUTORY OR OTHERWISE, RELATED TO THE INFORMATION, INCLUDING BUT NOT LIMITED TO ITS CONDITION, QUALITY, PERFORMANCE, MERCHANTABILITY OR FITNESS FOR PURPOSE. Microchip disclaims all liability arising from this information and its use. Use of Microchip devices in life support and/or safety applications is entirely at the buyer's risk, and the buyer agrees to defend, indemnify and hold harmless Microchip from any and all damages, claims, suits, or expenses resulting from such use. No licenses are conveyed, implicitly or otherwise, under any Microchip intellectual property rights.

Trademarks

The Microchip name and logo, the Microchip logo, dsPIC, KEELOQ, KEELOQ logo, MPLAB, PIC, PICmicro, PICSTART, rPIC and UNI/O are registered trademarks of Microchip Technology Incorporated in the U.S.A. and other countries.

FilterLab, Hampshire, HI-TECH C, Linear Active Thermistor, MXDEV, MXLAB, SEEVAL and The Embedded Control Solutions Company are registered trademarks of Microchip Technology Incorporated in the U.S.A.

Analog-for-the-Digital Age, Application Maestro, CodeGuard, dsPICDEM, dsPICDEM.net, dsPICworks, dsSPEAK, ECAN, ECONOMONITOR, FanSense, HI-TIDE, In-Circuit Serial Programming, ICSP, Mindi, MiWi, MPASM, MPLAB Certified logo, MPLIB, MPLINK, mTouch, Octopus, Omniscient Code Generation, PICC, PICC-18, PICDEM, PICDEM.net, PICkit, PICtail, PIC³² logo, REAL ICE, rLAB, Select Mode, Total Endurance, TSHARC, UniWinDriver, WiperLock and ZENA are trademarks of Microchip Technology Incorporated in the U.S.A. and other countries.

SQTP is a service mark of Microchip Technology Incorporated in the U.S.A.

All other trademarks mentioned herein are property of their respective companies.

© 2009, Microchip Technology Incorporated, Printed in the U.S.A., All Rights Reserved.

 Printed on recycled paper.

QUALITY MANAGEMENT SYSTEM
CERTIFIED BY DNV
== ISO/TS 16949:2002 ==

Microchip received ISO/TS-16949:2002 certification for its worldwide headquarters, design and wafer fabrication facilities in Chandler and Tempe, Arizona; Gresham, Oregon and design centers in California and India. The Company's quality system processes and procedures are for its PIC® MCUs and dsPIC® DSCs, KEELOQ® code hopping devices, Serial EEPROMs, microperipherals, nonvolatile memory and analog products. In addition, Microchip's quality system for the design and manufacture of development systems is ISO 9001:2000 certified.



WORLDWIDE SALES AND SERVICE

AMERICAS

Corporate Office
2355 West Chandler Blvd.
Chandler, AZ 85224-6199
Tel: 480-792-7200
Fax: 480-792-7277
Technical Support:
<http://support.microchip.com>
Web Address:
www.microchip.com

Atlanta
Duluth, GA
Tel: 678-957-9614
Fax: 678-957-1455

Boston
Westborough, MA
Tel: 774-760-0087
Fax: 774-760-0088

Chicago
Itasca, IL
Tel: 630-285-0071
Fax: 630-285-0075

Cleveland
Independence, OH
Tel: 216-447-0464
Fax: 216-447-0643

Dallas
Addison, TX
Tel: 972-818-7423
Fax: 972-818-2924

Detroit
Farmington Hills, MI
Tel: 248-538-2250
Fax: 248-538-2260

Kokomo
Kokomo, IN
Tel: 765-864-8360
Fax: 765-864-8387

Los Angeles
Mission Viejo, CA
Tel: 949-462-9523
Fax: 949-462-9608

Santa Clara
Santa Clara, CA
Tel: 408-961-6444
Fax: 408-961-6445

Toronto
Mississauga, Ontario,
Canada
Tel: 905-673-0699
Fax: 905-673-6509

ASIA/PACIFIC

Asia Pacific Office
Suites 3707-14, 37th Floor
Tower 6, The Gateway
Harbour City, Kowloon
Hong Kong
Tel: 852-2401-1200
Fax: 852-2401-3431

Australia - Sydney
Tel: 61-2-9868-6733
Fax: 61-2-9868-6755

China - Beijing
Tel: 86-10-8528-2100
Fax: 86-10-8528-2104

China - Chengdu
Tel: 86-28-8665-5511
Fax: 86-28-8665-7889

China - Hong Kong SAR
Tel: 852-2401-1200
Fax: 852-2401-3431

China - Nanjing
Tel: 86-25-8473-2460
Fax: 86-25-8473-2470

China - Qingdao
Tel: 86-532-8502-7355
Fax: 86-532-8502-7205

China - Shanghai
Tel: 86-21-5407-5533
Fax: 86-21-5407-5066

China - Shenyang
Tel: 86-24-2334-2829
Fax: 86-24-2334-2393

China - Shenzhen
Tel: 86-755-8203-2660
Fax: 86-755-8203-1760

China - Wuhan
Tel: 86-27-5980-5300
Fax: 86-27-5980-5118

China - Xiamen
Tel: 86-592-2388138
Fax: 86-592-2388130

China - Xian
Tel: 86-29-8833-7252
Fax: 86-29-8833-7256

China - Zhuhai
Tel: 86-756-3210040
Fax: 86-756-3210049

ASIA/PACIFIC

India - Bangalore
Tel: 91-80-3090-4444
Fax: 91-80-3090-4080

India - New Delhi
Tel: 91-11-4160-8631
Fax: 91-11-4160-8632

India - Pune
Tel: 91-20-2566-1512
Fax: 91-20-2566-1513

Japan - Yokohama
Tel: 81-45-471- 6166
Fax: 81-45-471-6122

Korea - Daegu
Tel: 82-53-744-4301
Fax: 82-53-744-4302

Korea - Seoul
Tel: 82-2-554-7200
Fax: 82-2-558-5932 or
82-2-558-5934

Malaysia - Kuala Lumpur
Tel: 60-3-6201-9857
Fax: 60-3-6201-9859

Malaysia - Penang
Tel: 60-4-227-8870
Fax: 60-4-227-4068

Philippines - Manila
Tel: 63-2-634-9065
Fax: 63-2-634-9069

Singapore
Tel: 65-6334-8870
Fax: 65-6334-8850

Taiwan - Hsin Chu
Tel: 886-3-6578-300
Fax: 886-3-6578-370

Taiwan - Kaohsiung
Tel: 886-7-536-4818
Fax: 886-7-536-4803

Taiwan - Taipei
Tel: 886-2-2500-6610
Fax: 886-2-2508-0102

Thailand - Bangkok
Tel: 66-2-694-1351
Fax: 66-2-694-1350

EUROPE

Austria - Wels
Tel: 43-7242-2244-39
Fax: 43-7242-2244-393

Denmark - Copenhagen
Tel: 45-4450-2828
Fax: 45-4485-2829

France - Paris
Tel: 33-1-69-53-63-20
Fax: 33-1-69-30-90-79

Germany - Munich
Tel: 49-89-627-144-0
Fax: 49-89-627-144-44

Italy - Milan
Tel: 39-0331-742611
Fax: 39-0331-466781

Netherlands - Drunen
Tel: 31-416-690399
Fax: 31-416-690340

Spain - Madrid
Tel: 34-91-708-08-90
Fax: 34-91-708-08-91

UK - Wokingham
Tel: 44-118-921-5869
Fax: 44-118-921-5820

03/26/09