

Mutter / nut

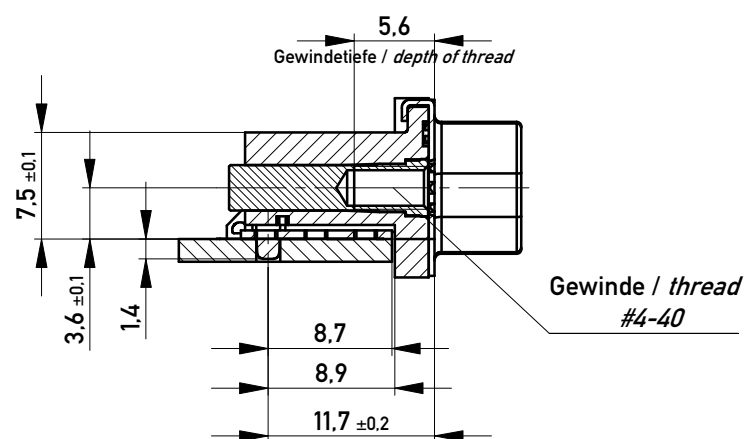

Anschlussbereich verzinkt
terminal area tin plating

Koplanarität der Anschlüsse $\leq 0,1$ mm
coplanarity area of termination $\leq 0,1$ mm

Anforderungsstufe: 2
class: 2

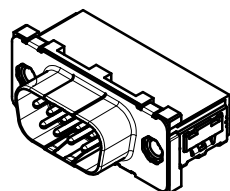

Verpackt in Tray
Verpackungseinheit 32 Stück

tray packaging
packaging unit 32 pcs

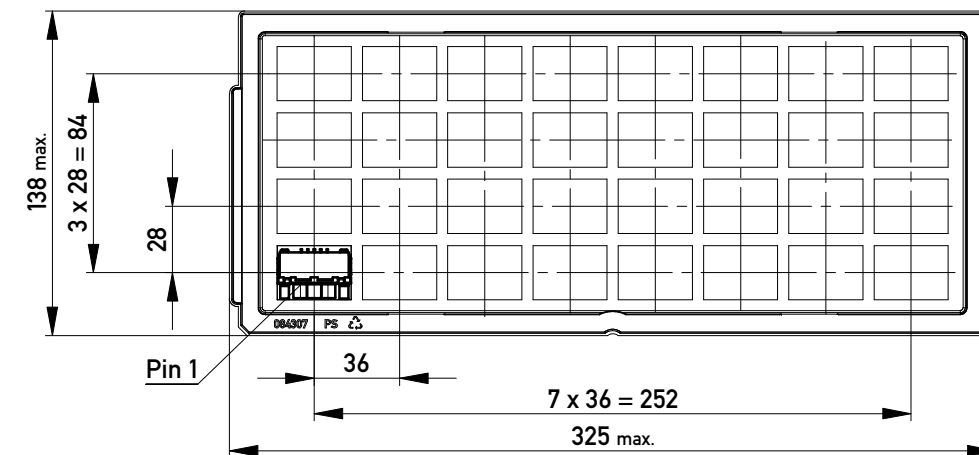

Sonstige Angaben siehe Zeichnung 204630 / additional indications according to drawing 204630

Layoutvorschlag
recommended layout

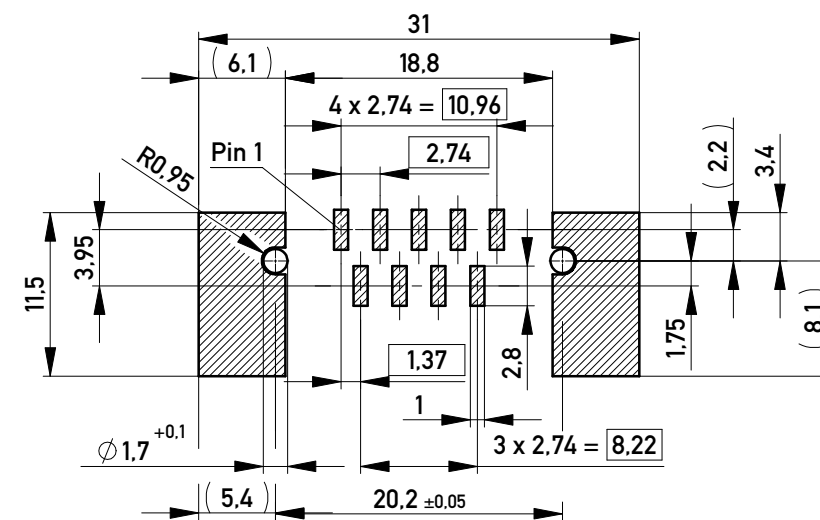

Fehlende Masse und Angaben siehe DIN 41652 / Missing information and dimensions according to DIN 41652
Sonstige Angaben siehe Fertigungsunterlagen / Additional indications according to production documentation

Information:	Tolerances	 All Dimensions in mm	Scale	2:1
	All rights reserved. Only for Information. To ensure that this is the latest version of this drawing, please contact one of the ERNI companies before using.		Designation TMC-P-09-SMD-Euro-BA8 TMC-P-09-SMD-Euro-BA8	
Copyright by ERNI GmbH Proprietary notice pursuant to ISO 16016 to be observed.		 www.ERNI.com	100201740001	
d	16.02.2012		Class TMCP	
Index	Date	K A3		