

Splash Proof Fan

φ172mm

San Ace 172W

51mm thick(Sidecut type WG type),
51mm thick(Sidecut type WE type)
51mm thick(Round type WE type)



General Specifications

- Material Frame: Aluminum, Impeller: Plastics (Flammability: UL94V-1)
- Expected Life Refer to specifications (Indoor,L10: Survival rate: 90% at 60°C , rated voltage, and continuously run in a free air state)
- Lead Wire ⊕red ⊖black (Sensor) yellow (Control) brown
- Storage Temperature -30°C to +70°C (Non-condensing)

φ172mm × 150mm × 51mm (Mass : 860g) **SideCut type IP55** Dust resistant device with protection against water jets **WGtype**

Specifications The following nos. have PWM controls and pulse sensors.

Model No.	Rated Voltage [V]	Operating Voltage Range [V]	PWM duty cycle* [%]	Rated Current [A]	Rated Input [W]	Rated Speed [min ⁻¹]	Max. Air Flow [m ³ /min] [CFM]	Max. Static Pressure [Pa] [inchH ₂ O]	SPL [dB(A)]	Operating Temperature [°C]	Expected Life ^{nom} [h]
9WG5748P5G001	48	40.8 to 55.2	100	2.91	140.0	8,600	15.46 546	1000 4.02	78	-10 to +70	40,000/60°C (70,000/40°C)
			0	0.21	10.1	2,000	3.59 127	75.1 0.30	40		
9WG5748P5H001			100	1.62	78.0	6,500	11.60 410	770 3.09	71		
			0	0.21	10.1	2,000	3.59 127	75.1 0.30	40		

Note: Expected life at 40°C ambient is just reference value.

※PWM Frequency : 25kHz

Available options: ⇒ **Without Sensor** **Pulse Sensor**

Dimensions (Unit : mm)

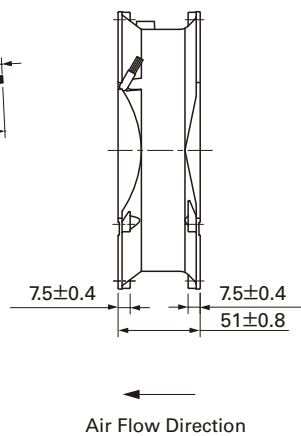
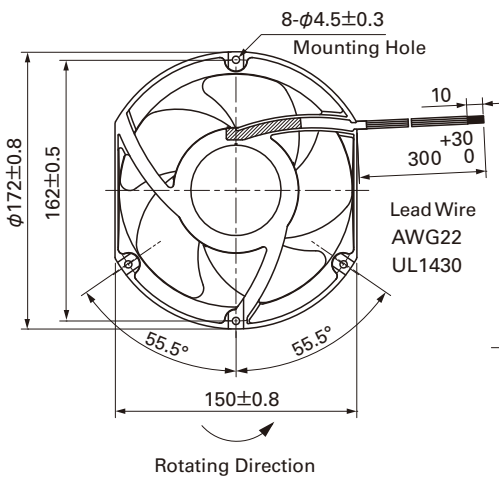

Reference dimension of mounting holes and vent opening (Unit : mm)

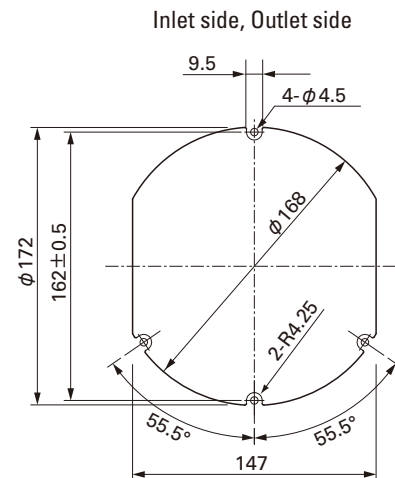

Options (Unit : mm)

Finger guards

Model : 109-319J Color Surface treatment : Nickel-chrome plating (silver)

For the finger guard Model: 109-319J, fix the finger guard to four holes as shown in the diagram.

Inlet side, Outlet side

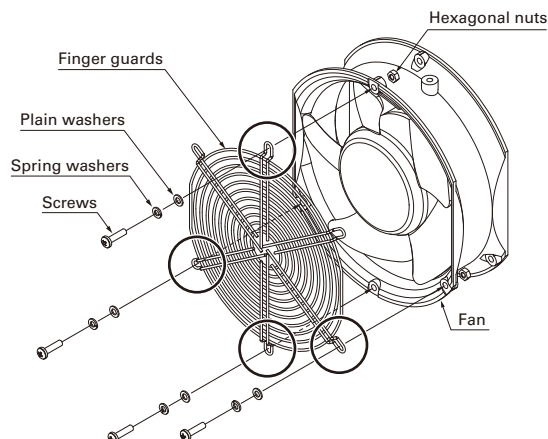
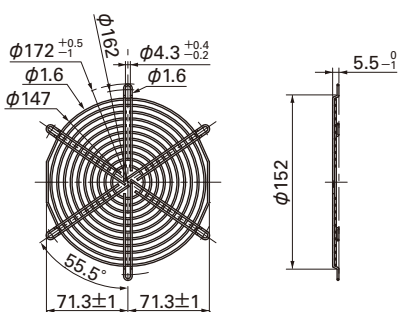

Options (Unit : mm)

Finger guards

Model : 109-319E Surface treatment : Nickel-chrome plating (silver) Color : 109-319H : Cation electropainting (black)

Model : 109-320 Surface treatment : Nickel-chrome plating (silver) Color :

For the finger guard Model: 109-319E, 109-319H, 109-320, fix the finger guard to two holes as shown in the diagram. Do not fix it to any other holes.

Inlet side, Outlet side

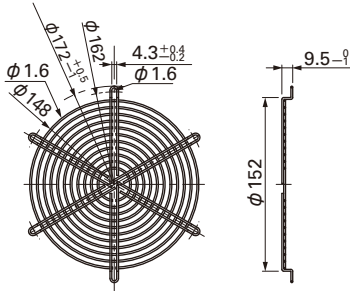

Outlet side

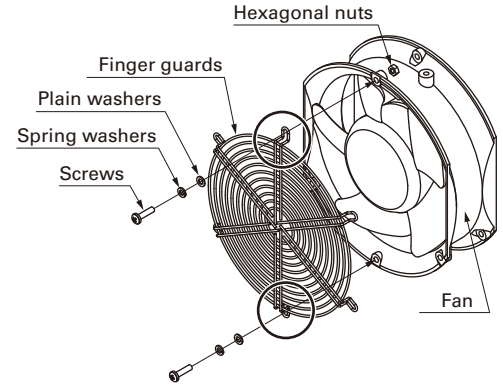
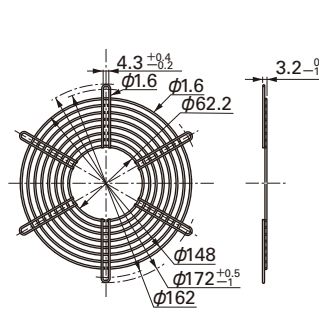

Air Flow - Static Pressure Characteristics

PWM Duty Cycle

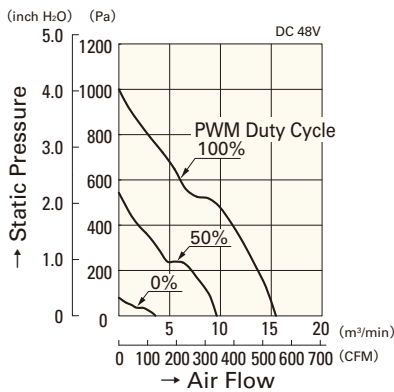

9WG5748P5G001

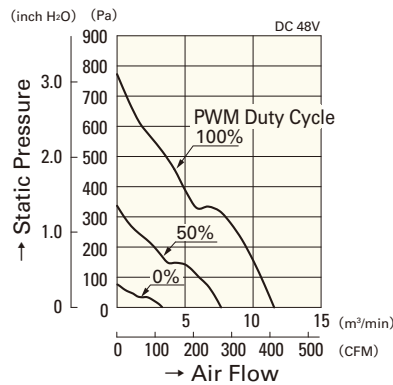

9WG5748P5H001

Operating Voltage Range

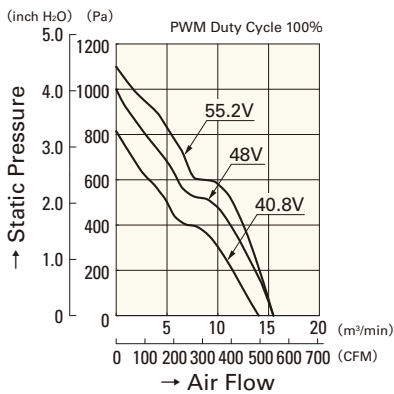

9WG5748P5G001

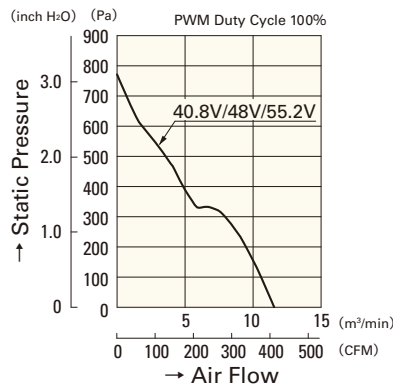

9WG5748P5H001

PWM Duty - Speed Characteristics Example

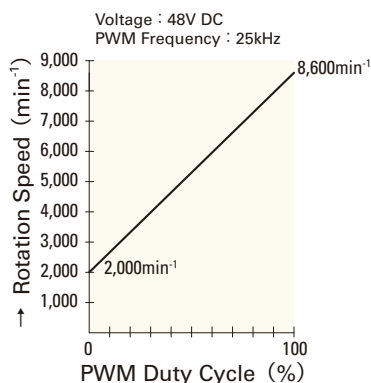

9WG5748P5G001

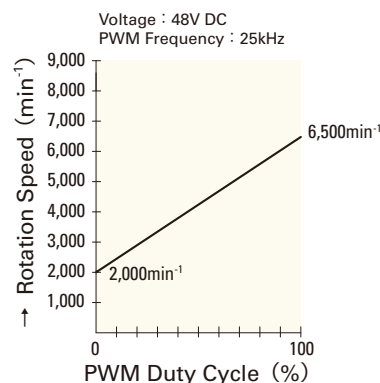

9WG5748P5H001