

## 14/16-Pin, Flash-Based 8-Bit CMOS Microcontrollers

### High-Performance RISC CPU:

- Only 35 Instructions to Learn:
  - All single-cycle instructions except branches
- Operating Speed:
  - DC – 20 MHz clock input
  - DC – 200 ns instruction cycle
- 2048 x 14 On-chip Flash Program Memory
- Self Read/Write Program Memory
- 128 x 8 General Purpose Registers (SRAM)
- Interrupt Capability
- 8-Level Deep Hardware Stack
- Direct, Indirect and Relative Addressing modes

### Microcontroller Features:

- Precision Internal Oscillator:
  - Factory calibrated to  $\pm 1\%$ , typical
  - Software selectable frequency: 8 MHz, 4 MHz, 1 MHz or 31 kHz
  - Software tunable
- Power-Saving Sleep mode
- Voltage Range (PIC16F753):
  - 2.0V to 5.5V
- Shunt Voltage Regulator (PIC16HV753):
  - 2.0V to user defined
  - 5-volt regulation
  - 1 mA to 50 mA shunt range
- Multiplexed Master Clear with Pull-up/Input Pin
- Interrupt-on-Change Pins
- Individually Programmable Weak Pull-ups
- Power-on Reset (POR)
- Power-up Timer (PWRT)
- Brown-out Reset (BOR)
- Watchdog Timer (WDT) with Internal Oscillator for Reliable Operation
- Industrial and Extended Temperature Range
- High Endurance Flash:
  - 100,000 write Flash endurance
  - Flash retention: >40 years
- Programmable Code Protection
- In-Circuit Debug (ICD) via Two Pins
- In-Circuit Serial Programming™ (ICSP™) via Two Pins

### Low-Power Features:

- Standby Current:
  - 50 nA @ 2.0V, typical
- Operating Current:
  - 11  $\mu$ A @ 32 kHz, 2.0V, typical
  - 260  $\mu$ A @ 4 MHz, 2.0V, typical
- Watchdog Timer Current:
  - <1  $\mu$ A @ 2.0V, typical

### Peripheral Features:

- 11 I/O Pins and one Input-only Pin
- High Current Source/Sink:
  - 50 mA I/O, (two pins)
  - 25 mA I/O, (nine pins)
- Two High-Speed Analog Comparator modules:
  - 50 ns response time
  - Fixed Voltage Reference (FVR)
  - Programmable on-chip voltage reference via integrated 9-bit DAC
  - Internal/external inputs and outputs (selectable)
  - Built-in Hysteresis (software selectable)
- A/D Converter:
  - 10-bit resolution
  - Eight external channels
  - Two internal reference voltage channels
- Operational Amplifier:
  - Three terminal operations
  - Internal connections to DAC and FVR
- Digital-to-Analog Converter (DAC):
  - 9-bit resolution
  - Full Range output
  - 4 mV steps @ 2.0V (Limited Range)
- Fixed Voltage Reference (FVR), 1.2V Reference
- Capture, Compare, PWM (CCP) module:
  - 16-bit Capture, max. resolution = 12.5 ns
  - 16-bit Compare, max. resolution = 200 ns
  - 10-bit PWM, max. frequency = 20 kHz
- Timer0: 8-Bit Timer/Counter with 8-Bit Prescaler
- Enhanced Timer1:
  - 16-bit Timer/Counter with Prescaler
  - External Timer1 Gate (count enable)
  - Four Selectable Clock sources
- Timer2: 8-Bit Timer/Counter with Prescaler
  - 8-Bit Period Register and Postscaler
- Two Hardware Limit Timers (HLT):
  - 8-bit Timer with Prescaler
  - 8-bit period register and postscaler
  - Asynchronous H/W Reset sources
- Complementary Output Generator (COG):
  - Complementary Waveforms from selectable sources
  - Two I/O (50 mA) for direct MOSFET drive
  - Rising and/or Falling edge dead-band control
  - Phase control, Blanking control
  - Auto-shutdown
  - Slope Compensation Circuit for use with SMPS power supplies

# PIC16F753/HV753

**TABLE 1: PIC16F753/HV753 FAMILY TYPES**

Device	Data Sheet Index	Program Memory Flash (words)	Self Read/Write Flash Memory	Data SRAM (bytes)	I/Os <sup>(2)</sup>	10-bit ADC (ch)	Comparators	Timers (8/16-bit)	CCP	Complementary Output Generator (COG)	DAC	Op Amp	Shunt Regulator	Debug <sup>(1)</sup>
PIC12F752	(1)	1K	Y	64	6	4	2	3/1	1	Y	5-bit	N	N	H
PIC12HV752	(1)	1K	Y	64	6	4	2	3/1	1	Y	5-bit	N	Y	H
PIC16F753	(2)	2K	Y	128	12	8	2	3/1	1	Y	9-bit	Y	N	I/H
PIC16HV753	(2)	2K	Y	128	12	8	2	3/1	1	Y	9-bit	Y	Y	I/H

**Note 1:** I - Debugging, Integrated on Chip; H - Debugging, Requires Debug Header.

**2:** One pin is input-only.

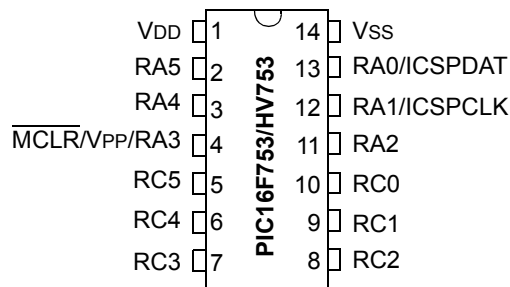
**Data Sheet Index:** (Unshaded devices are described in this document.)

1: DS41576 [PIC12F752/HV752 Data Sheet, 8-Pin Flash-Based, 8-Bit CMOS Microcontrollers.](#)

2: DS40001709 [PIC16F753/HV753 Data Sheet, 14/16-Pin Flash-based, 8-Bit CMOS Microcontrollers.](#)

**Note:** For other small form-factor package availability and marking information, please visit <http://www.microchip.com/packaging> or contact your local sales office.

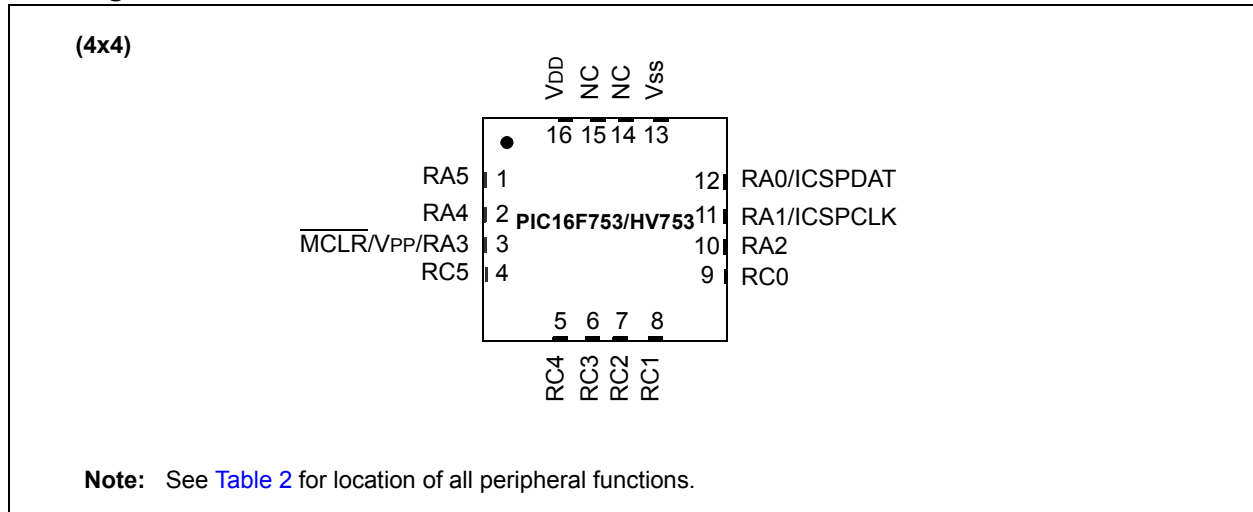
## Pin Diagram – 14-Pin PDIP, SOIC, TSSOP



**Note:** See [Table 2](#) for location of all peripheral functions.

# PIC16F753/HV753

## Pin Diagram – 16-Pin QFN



**TABLE 2: 14/16-PIN ALLOCATION TABLE FOR PIC16F753/HV753**

I/O	14-Pin PDIP/SOIC/TSSOP	16-Pin QFN	ADC	Reference	Op Amp	Comparator	Timer	CCP	Interrupt	Pull-up	Slope Compensation	Basic
RA0	13	12	AN0	FVROUT DACOUT	—	C1IN0+	—	—	IOC	Y	—	ICSPDAT
RA1	12	11	AN1	VREF FVRIN	—	C1IN0- C2IN0-	—	—	IOC	Y	—	ICSPCLK
RA2	11	10	AN2	COG1FLT	—	C1OUT	T0CKI	—	INT IOC	Y	—	—
RA3	4	3	—	—	—	—	T1G <sup>(2)</sup>	—	IOC	Y	—	MCLR/ VPP
RA4	3	2	AN3	—	—	—	T1G <sup>(1)</sup>	—	IOC	Y	—	CLKOUT
RA5	2	1	—	—	—	—	T1CKI	—	IOC	Y	—	CLKIN
RC0	10	9	AN4	—	OPAxIN+	C2IN0+	—	—	IOC	—	—	—
RC1	9	8	AN5	—	OPAxIN-	C1IN1- C2IN1-	—	—	IOC	—	—	—
RC2	8	7	AN6	—	OPAxOUT	C1IN2- C2IN2-	—	—	IOC	—	SLPCIN	—
RC3	7	6	AN7	—	—	C1IN3- C2IN3-	—	—	IOC	—	—	—
RC4	6	5	—	COG1OUT1	—	C2OUT	—	—	IOC	—	—	—
RC5	5	4	—	COG1OUT0	—	—	—	CCP1	IOC	—	—	—
VDD	1	16	—	—	—	—	—	—	—	—	—	VDD
VSS	14	13	—	—	—	—	—	—	—	—	—	VSS

**Note 1:** Default location for peripheral pin function. Alternate location can be selected using the APFCON register.  
**Note 2:** Alternate location for peripheral pin function selected by the APFCON register.

# PIC16F753/HV753

---

## Table of Contents

1.0	Device Overview .....	7
2.0	Memory Organization .....	11
3.0	Flash Program Memory Self Read/Self Write Control .....	27
4.0	Oscillator Module .....	37
5.0	I/O Ports .....	43
6.0	Timer0 Module .....	59
7.0	Timer1 Module with Gate Control .....	63
8.0	Timer2 Module .....	75
9.0	Hardware Limit Timer (HLT) Module .....	77
10.0	Capture/Compare/PWM Modules .....	81
11.0	Complementary Output Generator (COG) Module .....	89
12.0	Analog-to-Digital Converter (ADC) Module .....	113
13.0	Fixed Voltage Reference (FVR) .....	125
14.0	Digital-to-Analog Converter (DAC) Module .....	127
15.0	Comparator Module .....	133
16.0	Operational Amplifier (OPA) Module .....	143
17.0	Slope Compensator .....	145
18.0	Instruction Set Summary .....	151
19.0	Special Features of the CPU .....	161
20.0	Shunt Regulator (PIC12HV752 Only) .....	181
21.0	Development Support .....	183
22.0	Electrical Specifications .....	187
23.0	DC and AC Characteristics Graphs and Charts .....	213
24.0	Packaging Information .....	215
	Index .....	229
	The Microchip Web Site .....	233
	Customer Change Notification Service .....	233
	Customer Support .....	233
	Reader Response .....	234
	Product Identification System .....	235

## TO OUR VALUED CUSTOMERS

It is our intention to provide our valued customers with the best documentation possible to ensure successful use of your Microchip products. To this end, we will continue to improve our publications to better suit your needs. Our publications will be refined and enhanced as new volumes and updates are introduced.

If you have any questions or comments regarding this publication, please contact the Marketing Communications Department via E-mail at [docerrors@microchip.com](mailto:docerrors@microchip.com) or fax the **Reader Response Form** in the back of this data sheet to (480) 792-4150. We welcome your feedback.

### Most Current Data Sheet

To obtain the most up-to-date version of this data sheet, please register at our Worldwide Web site at:

<http://www.microchip.com>

You can determine the version of a data sheet by examining its literature number found on the bottom outside corner of any page. The last character of the literature number is the version number, (e.g., DS30000A is version A of document DS30000).

### Errata

An errata sheet, describing minor operational differences from the data sheet and recommended workarounds, may exist for current devices. As device/documentation issues become known to us, we will publish an errata sheet. The errata will specify the revision of silicon and revision of document to which it applies.

To determine if an errata sheet exists for a particular device, please check with one of the following:

- Microchip's Worldwide Web site; <http://www.microchip.com>
- Your local Microchip sales office (see last page)

When contacting a sales office, please specify which device, revision of silicon and data sheet (include literature number) you are using.

### Customer Notification System

Register on our web site at [www.microchip.com](http://www.microchip.com) to receive the most current information on all of our products.

# PIC16F753/HV753

---

NOTES:

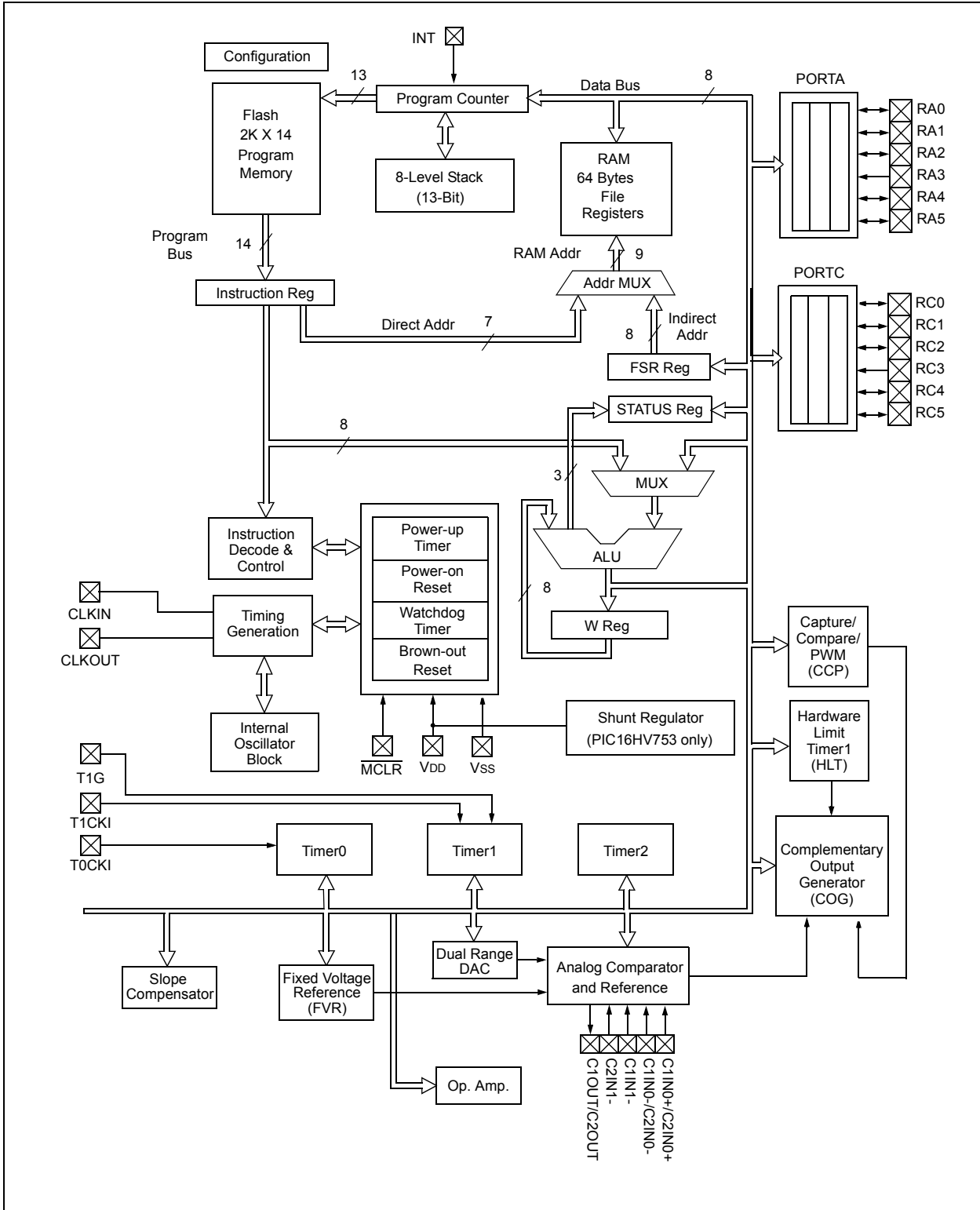
# PIC16F753/HV753

## 1.0 DEVICE OVERVIEW

Block Diagrams and pinout descriptions of the devices are shown in Figure 1-1 and Table 1-1.

The PIC16F753/HV753 devices are covered by this data sheet. They are available in 14-pin PDIP, SOIC, TSSOP and 16-pin QFN packages.

FIGURE 1-1: PIC16F753/HV753 BLOCK DIAGRAM



# PIC16F753/HV753

**TABLE 1-1: PIC16F753/HV753 PINOUT DESCRIPTION**

Name	Function	Input Type	Output Type	Description
RA0/C1IN0+/C2IN0+/AN0/ DACOUT/REFOUT/ ICSPDAT	RA0	TTL	HP	General purpose I/O with IOC and WPU.
	C1IN0+	AN	—	Comparator C1 positive input.
	C2IN0+	AN	—	Comparator C2 positive input.
	AN0	AN	—	A/D Channel 0 input.
	DACOUT	—	AN	DAC unbuffered Voltage Reference output.
	REFOUT	—	AN	DAC/FVR buffered Voltage Reference output.
	ICSPDAT	ST	HP	Serial Programming Data I/O.
RA1/C1IN0-/C2IN0-/AN1/ VREF+/FVRIN/ICSPCLK	RA1	TTL	CMOS	General purpose I/O with IOC and WPU.
	C1IN0-	AN	—	Comparator C1 negative input.
	C2IN0-	AN	—	Comparator C2 negative input.
	AN1	AN	—	A/D Channel 1 input.
	VREF+	AN	—	A/D Positive Voltage Reference input.
	FVRIN	AN	—	Voltage reference input.
	ICSPCLK	ST	—	Serial Programming Clock.
RA2/INT/CCP1/C2OUT/ C1OUT/T0CKI/ COG1OUT0 <sup>(2)</sup> /AN2/ COG1FLT	RA2	ST	HP	General purpose I/O with IOC and WPU.
	INT	ST	—	External interrupt.
	CCP1	ST	HP	Capture/Compare/PWM 1.
	C2OUT	—	HP	Comparator C2 output.
	C1OUT	—	HP	Comparator C1 output.
	T0CKI	ST	—	Timer0 clock input.
	COG1OUT0	—	HP	COG output channel 0.
	AN2	AN	—	A/D Channel 2 input.
	COG1FLT	ST	—	COG auto-shutdown fault input.
RA3 <sup>(1)</sup> /T1G <sup>(3)</sup> /VPP/MCLR <sup>(4)</sup>	RA3	TTL	—	General purpose input with WPU.
	T1G	ST	—	Timer1 Gate input.
	VPP	HV	—	Programming voltage.
	MCLR	ST	—	Master Clear w/internal pull-up.
RA4/T1G <sup>(2)</sup> /COG1OUT1 <sup>(3)</sup> / COG1FLT <sup>(2)</sup> /C1IN1-/AN3/ CLKOUT	RA4	TTL	CMOS	General purpose I/O with IOC and WPU.
	T1G	ST	—	Timer1 Gate input.
	COG1OUT1	—	CMOS	COG output channel 1
	COG1FLT	ST	—	COG auto-shutdown fault input.
	C1IN1-	AN	—	Comparator C1 negative input.
	AN3	AN	—	A/D Channel 3 input.
	CLKOUT	—	CMOS	Fosc/4 output.
RA5/T1CKI/COG1OUT0 <sup>(3)</sup> / C2IN1-/CLKIN	RA5	TTL	CMOS	General purpose I/O with IOC and WPU.
	T1CKI	ST	—	Timer1 clock input.
	COG1OUT0	—	CMOS	COG output channel 0.
	C2IN1-	AN	—	Comparator C2 negative input.
	CLKIN	ST	—	External Clock input (EC mode).

**Legend:** AN = Analog input or output    CMOS = CMOS compatible input or output  
TTL = TTL compatible input    ST = Schmitt Trigger input with CMOS levels  
HP = High Power    HV = High Voltage

\* Alternate pin function.

- Note** 1: Input only.  
2: Default pin function via the APFCON register.  
3: Alternate pin function via the APFCON register.  
4: RA3 pull-up is enabled when pin is configured as MCLR in Configuration Word.



**TABLE 1-1: PIC16F753/HV753 PINOUT DESCRIPTION (CONTINUED)**

Name	Function	Input Type	Output Type	Description
VDD	VDD	Power	—	Positive supply.
VSS	VSS	Power	—	Ground reference.
RC0/OPA1IN+/AN4/C2IN0+	RC0	TTL	CMOS	General purpose I/O.
	OPA1IN+	AN	—	Op amp positive input.
	AN4	AN	—	A/D Channel 4 input.
	C2IN0+	AN	—	Comparator C2 positive input.
RC1/OPA1IN-/AN5/C1IN1-/C2IN1-	RC1	TTL	CMOS	General purpose I/O.
	OPA1IN-	AN	—	Op amp negative input.
	AN5	AN	—	A/D Channel 5 input.
	C1IN1-	AN	—	Comparator C1 negative input.
RC2/SLPCIN/AN6/OPA1OUT/C1IN2-/C2IN2-	RC2	TTL	CMOS	General purpose I/O.
	SLPCIN	AN	—	Slope Compensator input.
	AN6	AN	—	A/D Channel 6 input.
	OPA1OUT	AN	HP	Op amp output.
	C1IN2-	AN	—	Comparator C1 negative input.
RC3/AN7/C1IN3-/C2IN3-	RC3	TTL	CMOS	General purpose I/O.
	AN7	AN	—	A/D Channel 7 input.
	C1IN3-	AN	—	Comparator C1 negative input.
	C2IN3-	AN	—	Comparator C2 negative input.
RC4/COG1OUT1/C2OUT	RC4	TTL	CMOS	General purpose I/O.
	COG1OUT1	—	CMOS	COG output Channel 1.
	C2OUT	—	HP	Comparator C2 output.
RC5/COG1OUT0/CCP1	RC5	TTL	CMOS	General purpose I/O.
	COG1OUT0	—	CMOS	COG output Channel 0.
	CCP1	—	HP	Capture/Compare/PWM 1.

**Legend:** AN = Analog input or output      CMOS = CMOS compatible input or output  
TTL = TTL compatible input      ST = Schmitt Trigger input with CMOS levels  
HP = High Power      HV = High Voltage

\* Alternate pin function.

- Note** 1: Input only.  
2: Default pin function via the APFCON register.  
3: Alternate pin function via the APFCON register.  
4: RA3 pull-up is enabled when pin is configured as MCLR in Configuration Word.

# PIC16F753/HV753

---

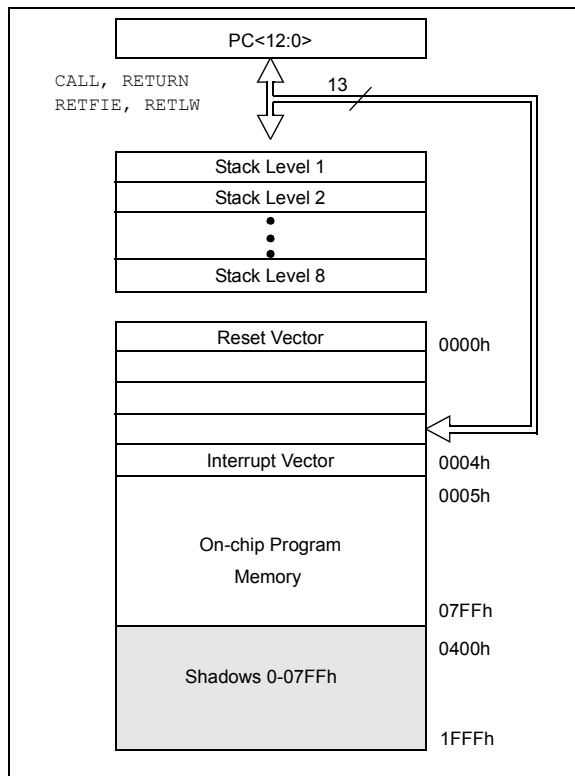
NOTES:

## 2.0 MEMORY ORGANIZATION

### 2.1 Program Memory Organization

The PIC16F753/HV753 has a 13-bit program counter capable of addressing an 8K x 14 program memory space. Only the first 2K x 14 (0000h-07FFh) is physically implemented. Accessing a location above these boundaries will cause a wrap-around within the first 2K x 14 space for PIC16F753/HV753. The Reset vector is at 0000h and the interrupt vector is at 0004h (see Figure 2-1).

**FIGURE 2-1: PROGRAM MEMORY MAP AND STACK FOR THE PIC16F753/HV753**



### 2.2 Data Memory Organization

The data memory (see Figure 2-2) is partitioned into four banks, which contain the General Purpose Registers (GPR) and the Special Function Registers (SFR). The Special Function Registers are located in the first 32 locations of each bank. Register locations 40h-6Fh in Bank 0 are General Purpose Registers, implemented as static RAM. Register locations 70h-7Fh in Bank 0 are Common RAM and shared as the last 16 addresses in all Banks. All other RAM is unimplemented and returns '0' when read. The RP<1:0> bits of the STATUS register are the bank select bits.

RP1	RP0	
0	0	→ Bank 0 is selected
0	1	→ Bank 1 is selected
1	0	→ Bank 2 is selected
1	1	→ Bank 3 is selected

#### 2.2.1 GENERAL PURPOSE REGISTER FILE

The register file is organized as 64 x 8 in the PIC16F753/HV753. Each register is accessed, either directly or indirectly, through the File Select Register (FSR) (see Section 2.5 "Indirect Addressing, INDF and FSR Registers").

#### 2.2.2 SPECIAL FUNCTION REGISTERS

The Special Function Registers are registers used by the CPU and peripheral functions for controlling the desired operation of the device (see Table 2-1). These registers are static RAM.

The special registers can be classified into two sets: core and peripheral. The Special Function Registers associated with the "core" are described in this section. Those related to the operation of the peripheral features are described in the section of that peripheral feature.

# PIC16F753/HV753

**FIGURE 2-2: DATA MEMORY MAP OF THE PIC16F753/HV753**

BANK 0		BANK 1		BANK 2		BANK 3	
INDF	00h	INDF	80h	INDF	100h	INDF	180h
TMR0	01h	OPTION_REG	81h	TMR0	101h	OPTION_REG	181h
PCL	02h	PCL	82h	PCL	102h	PCL	182h
STATUS	03h	STATUS	83h	STATUS	103h	STATUS	183h
FSR	04h	FSR	84h	FSR	104h	FSR	184h
PORTA	05h	TRISA	85h	LATA	105h	ANSELA	185h
—	06h	—	86h	—	106h	—	186h
PORTC	07h	TRISC	87h	LATC	107h	ANSELC	187h
IOCAF	08h	IOCAP	88h	IOCAN	108h	APFCON	188h
IOCCF	09h	IOCCP	89h	IOCCN	109h	OSCTUNE	189h
PCLATH	0Ah	PCLATH	8Ah	PCLATH	10Ah	PCLATH	18Ah
INTCON	0Bh	INTCON	8Bh	INTCON	10Bh	INTCON	18Bh
PIR1	0Ch	PIE1	8Ch	WPUA	10Ch	PMCON1	18Ch
PIR2	0Dh	PIE2	8Dh	WPUC	10Dh	PMCON2	18Dh
—	0Eh	—	8Eh	SLRCONC	10Eh	PMADRL	18Eh
TMR1L	0Fh	OSCCON	8Fh	PCON	10Fh	PMADRH	18Fh
TMR1H	10h	FVR1CON0	90h	TMR2	110h	PMDATL	190h
T1CON	11h	DAC1CON0	91h	PR2	111h	PMDATH	191h
T1GCON	12h	DAC1REFL	92h	T2CON	112h	COG1PHR	192h
CCPR1L	13h	DAC1REFH	93h	HLTMR1	113h	COG1PHF	193h
CCPR1H	14h	—	94h	HLTPR1	114h	COG1BKR	194h
CCP1CON	15h	—	95h	HLT1CON0	115h	COG1BKF	195h
—	16h	OPA1CON0	96h	HLT1CON1	116h	COG1DBR	196h
—	17h	—	97h	HLTMR2	117h	COG1DBF	197h
—	18h	—	98h	HLTPR2	118h	COG1CON0	198h
—	19h	—	99h	HLT2CON0	119h	COG1CON1	199h
—	1Ah	—	9Ah	HLT2CON1	11Ah	COG1RIS	19Ah
—	1Bh	CM2CON0	9Bh	—	11Bh	COG1RSIM	19Bh
ADRESL	1Ch	CM2CON1	9Ch	—	11Ch	COG1FIS	19Ch
ADRESH	1Dh	CM1CON0	9Dh	—	11Dh	COG1FSIM	19Dh
ADCON0	1Eh	CM1CON1	9Eh	SLPCCON0	11Eh	COG1ASD0	19Eh
ADCON1	1Fh	CMOUT	9Fh	SLPCCON1	11Fh	COG1ASD1	19Fh
GPRs “gpr0”	20h	GPRS “gpr1”	A0h	Unimplemented	120h	Unimplemented	1A0h
—	6Fh	—	BFh	—	16Fh	—	1EFh
GPRs “gprnobank”	70h	Unimplemented	C0h	GPRs “gpr2s” (mirrors “gprnobank”)	170h	GPRs “gpr2s” (mirrors “gprnobank”)	1F0h
—	7Fh	—	EFh	—	17Fh	—	1FFh
—	—	GPRs “gpr1s” (mirrors “gprnobank”)	F0h	—	—	—	—
—	—	—	FFh	—	—	—	—

**Legend:** ■ = Unimplemented data memory locations, read as ‘0’.

# PIC16F753/HV753

**TABLE 2-1: PIC16F753/HV753 SPECIAL REGISTERS SUMMARY BANK 0**

Addr	Name	Bit 7	Bit 6	Bit 5	Bit 4	Bit 3	Bit 2	Bit 1	Bit 0	Value on POR/BOR	Value on all other Resets		
<b>Bank 0</b>													
00h	INDF	INDF<7:0>								xxxx xxxx	xxxx xxxx		
01h	TMR0	TMR0<7:0>								xxxx xxxx	uuuu uuuu		
02h	PCL	PCL<7:0>								0000 0000	0000 0000		
03h	STATUS	IRP	RP1	RP0	$\overline{TO}$	$\overline{PD}$	Z	DC	C	0001 1xxx	000q quuu		
04h	FSR	FSR<7:0>								xxxx xxxx	uuuu uuuu		
05h	PORTA	—	—	RA5	RA4	RA3	RA2	RA1	RA0	--xx xxxx	--uu uuuu		
06h	—	Unimplemented								—	—		
07h	PORTC	—	—	RC5	RC4	RC3	RC2	RC1	RC0	--xx xxxx	--uu uuuu		
08h	IOCAF	—	—	IOCAF5	IOCAF4	IOCAF3	IOCAF2	IOCAF1	IOCAF0	--00 0000	--00 0000		
09h	IOCCF	—	—	IOCCF5	IOCCF4	IOCCF3	IOCCF2	IOCCF1	IOCCF0	--00 0000	--00 0000		
0Ah	PCLATH	—	—	—	PCLATH<4:0>					---	0000	---	0000
0Bh	INTCON	GIE	PEIE	TOIE	INTE	IOCFIE	TOIF	INTF	IOCFIF	0000 0000	0000 0000		
0Ch	PIR1	TMR1GIF	ADIF	—	—	HLTMR2IF	HLTMR1IF	TMR2IF	TMR1IF	00--0000	00--0000		
0Dh	PIR2	—	—	C2IF	C1IF	—	COG1IF	—	CCP1IF	--00 -0-0	--00 -0-0		
0Eh	—	Unimplemented								—	—		
0Fh	TMR1L	TMR1L<7:0>								xxxx xxxx	uuuu uuuu		
10h	TMR1H	TMR1H<7:0>								xxxx xxxx	uuuu uuuu		
11h	T1CON	TMR1CS<1:0>		T1CKPS<1:0>		T1OSCEN	$\overline{T1SYNC}$	—	TMR1ON	0000 00-0	0000 00-0		
12h	T1GCON	TMR1GE	T1GPOL	T1GTM	T1GSPM	T1GGO/DONE	T1GVAL	T1GSS<1:0>		0000 0x00	0000 0x00		
13h	CCPR1L	CCPR1L<7:0>								xxxx xxxx	uuuu uuuu		
14h	CCPR1H	CCPR1H<7:0>								xxxx xxxx	uuuu uuuu		
15h	CCP1CON	—	—	DC1B<1:0>		CCP1M<3:0>			—	--00 0000	--00 0000		
16h	—	Unimplemented								—	—		
17h	—	Unimplemented								—	—		
18h	—	Unimplemented								—	—		
19h	—	Unimplemented								—	—		
1Ah	—	Unimplemented								—	—		
1Bh	—	Unimplemented								—	—		
1Ch	ADRESL	Least Significant two bits of the left shifted result or eight bits of the right shifted result								xxxx xxxx	uuuu uuuu		
1Dh	ADRESH	Most Significant eight bits of the left shifted A/D result or two bits of the right shifted result								xxxx xxxx	uuuu uuuu		
1Eh	ADCON0	ADFM	—	CHS<3:0>				$\overline{GO/DONE}$	ADON	0-00 0000	0-00 0000		
1Fh	ADCON1	—	ADCS<2:0>			—	—	—	ADPREF1	-000 ---0	-000 ---0		

**Legend:** — = Unimplemented locations read as '0', u = unchanged, x = unknown, q = value depends on condition shaded = unimplemented.

# PIC16F753/HV753

**TABLE 2-2: PIC16F753/HV753 SPECIAL REGISTERS SUMMARY BANK 1**

Addr	Name	Bit 7	Bit 6	Bit 5	Bit 4	Bit 3	Bit 2	Bit 1	Bit 0	Value on POR/BOR	Values on all other Resets	
<b>Bank 1</b>												
80h	INDF	INDF<7:0>								xxxx xxxx	uuuu uuuu	
81h	OPTION_REG	$\overline{\text{RAPU}}$	INTEDG	T0CS	T0SE	PSA	PS<2:0>			1111 1111	1111 1111	
82h	PCL	PCL<7:0>								0000 0000	0000 0000	
83h	STATUS	IRP	RP1	RP0	$\overline{\text{TO}}$	$\overline{\text{PD}}$	Z	DC	C	0001 1xxx	000q quuu	
84h	FSR	FSR								xxxx xxxx	uuuu uuuu	
85h	TRISA	—	—	TRISA5	TRISA4	TRISA3	TRISA2	TRISA1	TRISA0	--11 1111	--11 1111	
86h	—	Unimplemented								—	—	
87h	TRISC	—	—	TRISC5	TRISC4	TRISC3	TRISC2	TRISC1	TRISC0	--11 1111	--11 1111	
88h	IOCAP	—	—	IOCAP5	IOCAP4	IOCAP3	IOCAP2	IOCAP1	IOCAP0	--00 0000	--00 0000	
89h	IOCCP	—	—	IOCCP5	IOCCP4	IOCCP3	IOCCP2	IOCCP1	IOCCP0	--00 0000	--00 0000	
8Ah	PCLATH	—	—	—	PCLATH<4:0>				---	0000	---	0000
8Bh	INTCON	GIE	PEIE	TOIE	INTE	IOCIE	T0IF	INTF	IOCIF	0000 0000	0000 0000	
8Ch	PIE1	TMR1GIE	ADIE	—	—	HLTMR2IE	HLTMR1IE	TMR2IE	TMR1IE	00-- 0000	00-- 0000	
8Dh	PIE2	—	—	C2IE	C1IE	—	COG1IE	—	CCP1IE	--00 -0-0	--00 -0-0	
8Eh	—	Unimplemented								—	—	
8Fh	OSCCON	—	—	IRCF<1:0>		—	HTS	LTS	—	--01 -0-	--uu -uu-	
90h	FVR1CON0	FVREN	FVRRDY	FVROE	FVRBUFSS1	FVRBUFSS0	—	—	FVRBUFEN	0000 0--0	0000 0--0	
91h	DAC1CON0	DACEN	DACFM	DACOE	—	DACPSS1	DACPSS0	—	—	000- 00--	000- 00--	
92h	DAC1REFL	Least Significant bit of the left shifted result or eight bits of the right shifted DAC setting								0000 0000	0000 0000	
93h	DAC1REFH	Most Significant eight bits of the left shifted DAC setting or first bit of the right shifted result								0000 0000	0000 0000	
94h	—	Unimplemented								—	—	
95h	—	Unimplemented								—	—	
96h	OPA1CON	OPA1EN	—	—	OPA1UGM	OPA1NCH<1:0>		OPA1PCH<1:0>		0--0 0000	0--0 0000	
97h	—	Unimplemented								—	—	
98h	—	Unimplemented								—	—	
99h	—	Unimplemented								—	—	
9Ah	—	Unimplemented								—	—	
9Bh	CM2CON0	C2ON	C2OUT	C2OE	C2POL	C2ZLF	C2SP	C2HYS	C2SYNC	0000 0100	0000 0100	
9Ch	CM2CON1	C2INTP	C2INTN	C2PCH<2:0>			C2NCH<2:0>			0000 0000	0000 0000	
9Dh	CM1CON0	C1ON	C1OUT	C1OE	C1POL	C1ZLF	C1SP	C1HYS	C1SYNC	0000 0100	0000 0100	
9Eh	CM1CON1	C1INTP	C1INTN	C1PCH<2:0>			C1NCH<2:0>			0000 0000	0000 0000	
9Fh	CMOUT	—	—	—	—	—	—	MCOUT2	MCOUT1	---- -00	---- -00	

**Legend:** — = Unimplemented locations read as '0', u = unchanged, x = unknown, q = value depends on condition shaded = unimplemented.

# PIC16F753/HV753

**TABLE 2-3: PIC16F753/HV753 SPECIAL REGISTERS SUMMARY BANK 2**

Addr	Name	Bit 7	Bit 6	Bit 5	Bit 4	Bit 3	Bit 2	Bit 1	Bit 0	Value on POR/BOR	Value on all other Resets	
<b>Bank 2</b>												
100h	INDF	INDF<7:0>								xxxx xxxx	xxxx xxxx	
101h	TMR0	TMR0<7:0>								xxxx xxxx	uuuu uuuu	
102h	PCL	PCL<7:0>								0000 0000	0000 0000	
103h	STATUS	IRP	RP1	RP0	$\overline{TO}$	$\overline{PD}$	Z	DC	C	0001 1xxx	000q quuu	
104h	FSR	FSR<7:0>								xxxx xxxx	uuuu uuuu	
105h	LATA	—	—	LATA5	LATA4	—	LATA2	LATA1	LATA0	--xx -xxx	--uu -uuu	
106h	—	Unimplemented								—	—	
107h	LATC	—	—	LATC5	LATC4	—	LATC2	LATC1	LATC0	--xx xxxx	--uu uuuu	
108h	IOCAN	—	—	IOCAN5	IOCAN4	IOCAN3	IOCAN2	IOCAN1	IOCAN0	--00 0000	--00 0000	
109h	IOCCN	—	—	IOCCN5	IOCCN4	IOCCN3	IOCCN2	IOCCN1	IOCCN0	--00 0000	--00 0000	
10Ah	PCLATH	—	—	—	PCLATH<4:0>				---	0000	---	0000
10Bh	INTCON	GIE	PEIE	T0IE	INTE	IOCFE	T0IF	INTF	IOCFIF	0000 0000	0000 0000	
10Ch	WPUA	—	—	WPUA5	WPUA4	WPUA3	WPUA2	WPUA1	WPUA0	--11 1111	--11 1111	
10Dh	WPUC	—	—	WPUC5	WPUC4	WPUC3	WPUC2	WPUC1	WPUC0	--11 1111	--11 1111	
10Eh	SLRCONC	—	—	SLRC5	SLRC4	—	—	—	—	--00 ----	--00 ----	
10Fh	PCON	—	—	—	—	—	—	$\overline{POR}$	$\overline{BOR}$	---- -qq	---- -uu	
110h	TMR2	TMR2<7:0>								0000 0000	0000 0000	
111h	PR2	PR2<7:0>								1111 1111	1111 1111	
112h	T2CON	—	T2OUTPS<3:0>				TMR2ON	T2CKPS<1:0>		-000 0000	-000 0000	
113h	HLTMR1	Holding Register for the 8-bit Hardware Limit Timer1 Count								0000 0000	0000 0000	
114h	HLTPR1	HLTMR1 Module Period Register								1111 1111	1111 1111	
115h	HLT1CON0	—	H1OUTPS<3:0>				H1ON	H1CKPS<1:0>		-000 0000	-000 0000	
116h	HLT1CON1	H1FES	H1RES	—	H1ERS<2:0>			H1FEREN	H1REREN	11-0 0000	11-0 0000	
117h	HLTMR2	Holding Register for the 8-bit Hardware Limit Timer2 Count								0000 0000	0000 0000	
118h	HLTPR2	HLTMR2 Module Period Register								1111 1111	1111 1111	
119h	HLT2CON0	—	H2OUTPS<3:0>				H2ON	H2CKPS<1:0>		-000 0000	-000 0000	
11Ah	HLT2CON1	H2FES	H2RES	—	H2ERS<2:0>			H2FEREN	H2REREN	11-0 0000	11-0 0000	
11Bh	—	Unimplemented								—	—	
11Ch	—	Unimplemented								—	—	
11Dh	—	Unimplemented								—	—	
11Eh	SLPCCON0	SC1EN	—	—	SC1POL	SC1TSS1	SC1TSS0	—	SC1INS	0-00 00-0	0-00 00-0	
11Fh	SLPCCON1	—	—	—	SC1RNG	SC1ISET<3:0>			---	0000	---	0000

**Legend:** — = Unimplemented locations read as '0', u = unchanged, x = unknown, q = value depends on condition shaded = unimplemented.

# PIC16F753/HV753

**TABLE 2-4: PIC16F753/HV753 SPECIAL FUNCTION REGISTERS SUMMARY BANK 3**

Addr	Name	Bit 7	Bit 6	Bit 5	Bit 4	Bit 3	Bit 2	Bit 1	Bit 0	Value on POR/BOR	Values on all other Resets
<b>Bank 3</b>											
180h	INDF	INDF<7:0>								xxxx xxxx	uuuu uuuu
181h	OPTION_REG	RAPU	INTEDG	T0CS	T0SE	PSA	PS<2:0>			1111 1111	1111 1111
182h	PCL	PCL<7:0>								0000 0000	0000 0000
183h	STATUS	IRP	RP1	RP0	T0	PD	Z	DC	C	0001 1xxx	000q quuu
184h	FSR	FSR<7:0>								xxxx xxxx	uuuu uuuu
185h	ANSELA	—	—	—	ANSA4	—	ANSA2	ANSA1	ANSA0	---1 -111	---1 -111
186h	—	Unimplemented								—	—
187h	ANSELC	—	—	—	—	ANSC3	ANSC2	ANSC1	ANSC0	---- 0000	---- 0000
188h	APFCON	—	—	—	T1GSEL	—	—	—	—	---0 ----	---0 ----
189h	OSCTUNE	—	—	—	TUN<4:0>					---0 0000	---0 0000
18Ah	PCLATH	—	—	—	PCLATH<4:0>					---0 0000	---0 0000
18Bh	INTCON	GIE	PEIE	T0IE	INTE	IOCFE	T0IF	INTF	IOCF	0000 0000	0000 0000
18Ch	PMCON1	—	—	—	—	—	WREN	WR	RD	---- -000	---- -000
18Dh	PMCON2	Program Memory Control Register 2								---- ----	---- ----
18Eh	PMADRL	PMADRL<7:0>								0000 0000	0000 0000
18Fh	PMADRH	—	—	—	—	—	PMADRH<1:0>			---- --00	---- --00
190h	PMDATL	PMDATL<7:0>								0000 0000	0000 0000
191h	PMDATH	—	—	PMDATH<5:0>						--00 0000	--00 0000
192h	COG1PHR	—	—	—	—	G1PHR<3:0>			---- xxxx	---- uuuu	
193h	COG1PHF	—	—	—	—	G1PHF<3:0>			---- xxxx	---- uuuu	
194h	COG1BKR	—	—	—	—	G1BLKR<3:0>			---- xxxx	---- uuuu	
195h	COG1BKF	—	—	—	—	G1BLKF<3:0>			---- xxxx	---- uuuu	
196h	COG1DBR	—	—	—	—	G1DBR<3:0>			---- xxxx	---- uuuu	
197h	COG1DBF	—	—	—	—	G1DBF<3:0>			---- xxxx	---- uuuu	
198h	COG1CON0	G1EN	G1OE1	G1OE0	G1POL1	G1POL0	G1LD	—	G1MD	0000 00-0	0000 00-0
199h	COG1CON1	G1RDBTS	G1FDBTS	—	—	—	—	G1CS<1:0>		00-- --00	00-- --00
19Ah	COG1RIS	—	G1RIHLT2	G1RIHLT1	G1RIT2M	G1RIFLT	G1RICCP1	G1RIC2	G1RIC1	0000 0000	0000 0000
19Bh	COG1RSIM	—	G1RMHLT2	G1RMHLT1	G1RMT2M	G1RMFLT	G1RMCCP1	G1RMC2	G1RMC1	0000 0000	0000 0000
19Ch	COG1FIS	—	G1FIHLT2	G1FIHLT1	G1FIT2M	G1FIFLT	G1FICCP1	G1FIC2	G1FIC1	0000 0000	0000 0000
19Dh	COG1FSIM	—	G1FMHLT2	G1FMHLT1	G1FMT2M	G1FMFLT	G1FMCCP1	G1FMC2	G1FMC1	0000 0000	0000 0000
19Eh	COG1ASD0	C1ASDE	C1ARSEN	G1ASD1L<1:0>		G1ASD0L<1:0>		—	—	0000 00--	0000 00--
19Fh	COG1ASD1	—	—	—	G1ASD1SHLT2	G1ASD1SHLT1	G1ASD1DSC2	G1ASD1DSC1	G1ASD1SFLT	0000 0000	0000 0000

**Legend:** — = Unimplemented locations read as '0', u = unchanged, x = unknown, q = value depends on condition shaded = unimplemented



## 2.3 Global SFRs

### 2.3.1 STATUS REGISTER

The STATUS register, shown in [Register 2-1](#), contains:

- the arithmetic status of the ALU
- the Reset status
- the bank select bits for data memory (RAM)

The STATUS register can be the destination for any instruction, like any other register. If the STATUS register is the destination for an instruction that affects the Z, DC or C bits, then the write to these three bits is disabled. These bits are set or cleared according to the device logic. Furthermore, the  $\overline{\text{TO}}$  and  $\overline{\text{PD}}$  bits are not

writable. Therefore, the result of an instruction with the STATUS register as destination may be different than intended.

For example, `CLRF STATUS`, will clear the upper three bits and set the Z bit. This leaves the STATUS register as `'000u u1uu'` (where u = unchanged).

It is recommended, therefore, that only `BCF`, `BSF`, `SWAPF` and `MOVWF` instructions are used to alter the STATUS register, because these instructions do not affect any Status bits. For other instructions not affecting any Status bits, see [Section 18.0 "Instruction Set Summary"](#).

#### REGISTER 2-1: STATUS: STATUS REGISTER

R/W-0	R/W-0	R/W-0	R-1	R-1	R/W-x	R/W-x	R/W-x
IRP	RP1	RP0	$\overline{\text{TO}}$	$\overline{\text{PD}}$	Z	DC <sup>(1)</sup>	C <sup>(1)</sup>
bit 7							bit 0

#### Legend:

R = Readable bit	W = Writable bit	U = Unimplemented bit, read as '0'
-n = Value at POR	'1' = Bit is set	'0' = Bit is cleared
		x = Bit is unknown

bit 7	<b>IRP:</b> Register Bank Select bit (used for indirect addressing) 1 = Bank 2, 3 (100h-1FFh) 0 = Bank 0, 1 (00h-FFh)
bit 6	<b>RP1:</b> Register Bank Select bit (used for direct addressing) 00 = Bank 0 (00h-7Fh) 01 = Bank 1 (80h-FFh) 10 = Bank 2 (100h-17Fh) 11 = Bank 3 (180h-1FFh)
bit 5	<b>RP0:</b> Register Bank Select bit (used for direct addressing) 1 = Bank 1 (80h-FFh) 0 = Bank 0 (00h-7Fh)
bit 4	<b><math>\overline{\text{TO}}</math>:</b> Time-Out bit 1 = After power-up, <code>CLRWDT</code> instruction or <code>SLEEP</code> instruction 0 = A WDT time-out occurred
bit 3	<b><math>\overline{\text{PD}}</math>:</b> Power-Down bit 1 = After power-up or by the <code>CLRWDT</code> instruction 0 = By execution of the <code>SLEEP</code> instruction
bit 2	<b>Z:</b> Zero bit 1 = The result of an arithmetic or logic operation is zero 0 = The result of an arithmetic or logic operation is not zero
bit 1	<b>DC:</b> Digit Carry/Borrow bit <sup>(2)</sup> ( <code>ADDWF</code> , <code>ADDLW</code> , <code>SUBLW</code> , <code>SUBWF</code> instructions), For Borrow, the polarity is reversed. 1 = A carry-out from the 4th low-order bit of the result occurred 0 = No carry-out from the 4th low-order bit of the result
bit 0	<b>C:</b> Carry/Borrow bit <sup>(2)</sup> ( <code>ADDWF</code> , <code>ADDLW</code> , <code>SUBLW</code> , <code>SUBWF</code> instructions) 1 = A carry-out from the Most Significant bit of the result occurred 0 = No carry-out from the Most Significant bit of the result occurred

**Note 1:** The C and DC bits operate as a  $\overline{\text{Borrow}}$  and  $\overline{\text{Digit Borrow}}$  out bit, respectively, in subtraction. See the `SUBLW` and `SUBWF` instructions for examples.

**Note 2:** For Borrow, the polarity is reversed. A subtraction is executed by adding the two's complement of the second operand. For rotate (`RRE`, `RLF`) instructions, this bit is loaded with either the high-order or low-order bit of the source register.

# PIC16F753/HV753

## 2.3.2 OPTION REGISTER

The OPTION register is a readable and writable register, which contains various control bits to configure:

- Timer0/WDT prescaler
- External RA2/INT interrupt
- Timer0
- Weak pull-ups on PORTA

**Note:** To achieve a 1:1 prescaler assignment for Timer0, assign the prescaler to the WDT by setting PSA bit to '1' of the OPTION register. See **Section 6.1.3 "Software Programmable Prescaler"**.

### REGISTER 2-2: OPTION\_REG: OPTION REGISTER

R/W-1	R/W-1	R/W-1	R/W-1	R/W-1	R/W-1	R/W-1	R/W-1
$\overline{\text{RAPU}}$	INTEDG	T0CS	T0SE	PSA	PS<2:0>		
bit 7							bit 0

**Legend:**

R = Readable bit	W = Writable bit	U = Unimplemented bit, read as '0'
-n = Value at POR	'1' = Bit is set	'0' = Bit is cleared      x = Bit is unknown

- bit 7       **$\overline{\text{RAPU}}$ :** PORTA Pull-up Enable bit  
 1 = PORTA pull-ups are disabled  
 0 = PORTA pull-ups are enabled by individual PORT latch values
- bit 6      **INTEDG:** Interrupt Edge Select bit  
 1 = Interrupt on rising edge of INT pin  
 0 = Interrupt on falling edge of INT pin
- bit 5      **T0CS:** Timer0 Clock Source Select bit  
 1 = Transition on T0CKI pin  
 0 = Internal instruction cycle clock (FOSC/4)
- bit 4      **T0SE:** Timer0 Source Edge Select bit  
 1 = Increment on high-to-low transition on T0CKI pin  
 0 = Increment on low-to-high transition on T0CKI pin
- bit 3      **PSA:** Prescaler Assignment bit  
 1 = Prescaler is assigned to the WDT  
 0 = Prescaler is assigned to the Timer0 module
- bit 2-0    **PS<2:0>:** Prescaler Rate Select bits

BIT VALUE	TIMER0 RATE	WDT RATE
000	1 : 2	1 : 1
001	1 : 4	1 : 2
010	1 : 8	1 : 4
011	1 : 16	1 : 8
100	1 : 32	1 : 16
101	1 : 64	1 : 32
110	1 : 128	1 : 64
111	1 : 256	1 : 128

## 2.3.3 INTCON REGISTER

The INTCON register is a readable and writable register, which contains the various enable and flag bits for TMR0 register overflow, IOCIE change and external RA2/INT pin interrupts.

**Note:** Interrupt flag bits are set when an interrupt condition occurs, regardless of the state of its corresponding enable bit or the Global Enable bit, GIE of the INTCON register. User software should ensure the appropriate interrupt flag bits are clear prior to enabling an interrupt.

### REGISTER 2-3: INTCON: INTERRUPT CONTROL REGISTER

R/W-0	R/W-0	R/W-0	R/W-0	R/W-0	R/W-0	R/W-0	R/W-0
GIE	PEIE	T0IE	INTE	IOCIE	T0IF	INTF	IOCIF
bit 7							bit 0

**Legend:**

R = Readable bit	W = Writable bit	U = Unimplemented bit, read as '0'
-n = Value at POR	'1' = Bit is set	'0' = Bit is cleared      x = Bit is unknown

- bit 7      **GIE:** Global Interrupt Enable bit  
1 = Enables all unmasked interrupts  
0 = Disables all interrupts
- bit 6      **PEIE:** Peripheral Interrupt Enable bit  
1 = Enables all unmasked peripheral interrupts  
0 = Disables all peripheral interrupts
- bit 5      **T0IE:** Timer0 Overflow Interrupt Enable bit  
1 = Enables the Timer0 interrupt  
0 = Disables the Timer0 interrupt
- bit 4      **INTE:** RA2/INT External Interrupt Enable bit  
1 = Enables the RA2/INT external interrupt  
0 = Disables the RA2/INT external interrupt
- bit 3      **IOCIE:** Interrupt-on-Change Interrupt Enable bit<sup>(1)</sup>  
1 = Enables the IOC change interrupt  
0 = Disables the IOC change interrupt
- bit 2      **T0IF:** Timer0 Overflow Interrupt Flag bit<sup>(2)</sup>  
1 = Timer0 register has overflowed (must be cleared in software)  
0 = Timer0 register did not overflow
- bit 1      **INTF:** RA2/INT External Interrupt Flag bit  
1 = The RA2/INT external interrupt occurred (must be cleared in software)  
0 = The RA2/INT external interrupt did not occur
- bit 0      **IOCIF:** Interrupt-on-Change Interrupt Flag bit  
1 = An IOC pin has changed state and generated an interrupt  
0 = No pin interrupts have been generated

- Note 1:** IOC register must also be enabled.
- 2:** T0IF bit is set when TMR0 rolls over. TMR0 is unchanged on Reset and should be initialized before clearing T0IF bit.

# PIC16F753/HV753

## 2.3.4 PIE1 REGISTER

The PIE1 register contains the Peripheral Interrupt Enable bits, as shown in [Register 2-4](#).

**Note:** Bit PEIE of the INTCON register must be set to enable any peripheral interrupt.

### REGISTER 2-4: PIE1: PERIPHERAL INTERRUPT ENABLE REGISTER 1

R/W-0	R/W-0	U-0	U-0	R/W-0	R/W-0	R/W-0	R/W-0
TMR1GIE	ADIE	—	—	HLTMR2IE	HLTMR1IE	TMR2IE	TMR1IE
bit 7							bit 0

#### Legend:

R = Readable bit

W = Writable bit

U = Unimplemented bit, read as '0'

-n = Value at POR

'1' = Bit is set

'0' = Bit is cleared

x = Bit is unknown

- bit 7      **TMR1GIE:** ADC Interrupt Enable bit  
1 = Enables the TMR1 gate interrupt  
0 = Disables the TMR1 gate interrupt
- bit 6      **ADIE:** ADC Interrupt Enable bit  
1 = Enables the ADC interrupt  
0 = Disables the ADC interrupt
- bit 5-4    **Unimplemented:** Read as '0'
- bit 3      **HLTMR2IE:** HLT2 Interrupt Enable bit  
1 = Enables the HLT2 interrupt  
0 = Disables the HLT2 interrupt
- bit 2      **HLTMR1IE:** HLT1 Interrupt Enable bit  
1 = Enables the HLT1 interrupt  
0 = Disables the HLT1 interrupt
- bit 1      **TMR2IE:** Timer2 Interrupt Enable bit  
1 = Enables the Timer2 interrupt  
0 = Disables the Timer2 interrupt
- bit 0      **TMR1IE:** Timer1 Interrupt Enable bit  
1 = Enables the Timer1 interrupt  
0 = Disables the Timer1 interrupt

## 2.3.5 PIE2 REGISTER

The PIE2 register contains the Peripheral Interrupt Enable bits, as shown in [Register 2-5](#).

**Note:** Bit PEIE of the INTCON register must be set to enable any peripheral interrupt.

### REGISTER 2-5: PIE2: PERIPHERAL INTERRUPT ENABLE REGISTER 1

U-0	U-0	R/W-0	R/W-0	U-0	R/W-0	U-0	R/W-0
—	—	C2IE	C1IE	—	COG1IE	—	CCP1IE
bit 7							bit 0

**Legend:**

R = Readable bit	W = Writable bit	U = Unimplemented bit, read as '0'
-n = Value at POR	'1' = Bit is set	'0' = Bit is cleared
		x = Bit is unknown

- bit 7-6      **Unimplemented:** Read as '0'
- bit 5      **C2IE:** Comparator 2 Interrupt Enable bit  
1 = Enables the Comparator 2 interrupt  
0 = Disables the Comparator 2 interrupt
- bit 4      **C1IE:** Comparator 1 Interrupt Enable bit  
1 = Enables the Comparator 1 interrupt  
0 = Disables the Comparator 1 interrupt
- bit 3      **Unimplemented:** Read as '0'
- bit 2      **COG1IE:** COG 1 Interrupt Flag bit  
1 = COG1 interrupt enabled  
0 = COG1 interrupt disabled
- bit 1      **Unimplemented:** Read as '0'
- bit 0      **CCP1IE:** CCP1 Interrupt Enable bit  
1 = Enables the CCP1 interrupt  
0 = Disables the CCP1 interrupt

# PIC16F753/HV753

## 2.3.6 PIR1 REGISTER

The PIR1 register contains the Peripheral Interrupt flag bits, as shown in [Register 2-6](#).

**Note:** Interrupt flag bits are set when an interrupt condition occurs, regardless of the state of its corresponding enable bit or the Global Enable bit, GIE of the INTCON register. User software should ensure the appropriate interrupt flag bits are clear prior to enabling an interrupt.

### REGISTER 2-6: PIR1: PERIPHERAL INTERRUPT REQUEST REGISTER 1

R/W-0	R/W-0	U-0	U-0	R/W-0	R/W-0	R/W-0	R/W-0
TMR1GIF	ADIF	—	—	HLTMR2IF	HLTMR1IF	TMR2IF	TMR1IF
bit 7							bit 0

#### Legend:

R = Readable bit	W = Writable bit	U = Unimplemented bit, read as '0'
-n = Value at POR	'1' = Bit is set	'0' = Bit is cleared
		x = Bit is unknown

- bit 7      **TMR1GIF:** TMR1 Gate Interrupt Flag bit  
           1 = Timer1 gate interrupt is pending  
           0 = Timer1 gate interrupt is not pending
- bit 6      **ADIF:** ADC Interrupt Flag bit  
           1 = ADC conversion complete  
           0 = ADC conversion has not completed or has not been started
- bit 5-4    **Unimplemented:** Read as '0'
- bit 3      **HLTMR2IF:** HLT2 to HLTMR2 Match Interrupt Flag bit  
           1 = HLT2 to HLTMR2 match occurred (must be cleared in software)  
           0 = HLT2 to HLTMR2 match did not occur
- bit 2      **HLTMR1IF:** HLT1 to HLTMR1 Match Interrupt Flag bit  
           1 = HLT1 to HLTMR1 match occurred (must be cleared in software)  
           0 = HLT1 to HLTMR1 match did not occur
- bit 1      **TMR2IF:** Timer2 to PR2 Match Interrupt Flag bit  
           1 = Timer2 to PR2 match occurred (must be cleared in software)  
           0 = Timer2 to PR2 match did not occur
- bit 0      **TMR1IF:** Timer1 Interrupt Flag bit  
           1 = Timer1 rolled over (must be cleared in software)  
           0 = Timer1 has not rolled over

## 2.3.7 PIR2 REGISTER

The PIR2 register contains the Peripheral Interrupt flag bits, as shown in [Register 2-7](#).

**Note:** Interrupt flag bits are set when an interrupt condition occurs, regardless of the state of its corresponding enable bit or the Global Enable bit, GIE of the INTCON register. User software should ensure the appropriate interrupt flag bits are clear prior to enabling an interrupt.

### REGISTER 2-7: PIR2: PERIPHERAL INTERRUPT REQUEST REGISTER 1

U-0	U-0	R/W-0	R/W-0	U-0	R/W-0	U-0	R/W-0
—	—	C2IF	C1IF	—	COG1IF	—	CCP1IF
bit 7							bit 0

**Legend:**

R = Readable bit	W = Writable bit	U = Unimplemented bit, read as '0'
-n = Value at POR	'1' = Bit is set	'0' = Bit is cleared      x = Bit is unknown

- bit 7-6      **Unimplemented:** Read as '0'
- bit 5      **C2IF:** Comparator 1 Interrupt Flag bit
  - 1 = Comparator output (C2OUT bit) has changed (must be cleared in software)
  - 0 = Comparator output (C2OUT bit) has not changed
- bit 4      **C1IF:** Comparator 1 Interrupt Flag bit
  - 1 = Comparator output (C1OUT bit) has changed (must be cleared in software)
  - 0 = Comparator output (C1OUT bit) has not changed
- bit 3      **Unimplemented:** Read as '0'
- bit 2      **COG1IF:** COG 1 Interrupt Flag bit
  - 1 = COG1 has generated an auto-shutdown interrupt
  - 0 = COG1 has NOT generated an auto-shutdown interrupt
- bit 1      **Unimplemented:** Read as '0'
- bit 0      **CCP1IF:** ECCP Interrupt Flag bit
  - Capture Mode
    - 1 = A TMR1 register capture occurred (must be cleared in software)
    - 0 = No TMR1 register capture occurred
  - Compare Mode
    - 1 = A TMR1 register compare match occurred (must be cleared in software)
    - 0 = No TMR1 register compare match occurred
  - PWM mode  
Unused in this mode

# PIC16F753/HV753

## 2.3.8 PCON REGISTER

The Power Control (PCON) register (see [Table 19-2](#)) contains flag bits to differentiate between a:

- Power-on Reset ( $\overline{\text{POR}}$ )
- Brown-out Reset ( $\overline{\text{BOR}}$ )
- Watchdog Timer Reset (WDT)
- External MCLR Reset

The PCON register also controls the software enable of the  $\overline{\text{BOR}}$ .

The PCON register bits are shown in [Register 2-8](#).

### REGISTER 2-8: PCON: POWER CONTROL REGISTER

U-0	U-0	U-0	U-0	U-0	U-0	R/W-q/u	R/W-q/u
—	—	—	—	—	—	$\overline{\text{POR}}$	$\overline{\text{BOR}}$
bit 7						bit 0	

#### Legend:

R = Readable bit

W = Writable bit

U = Unimplemented bit, read as '0'

u = Bit is unchanged

x = Bit is unknown

-n/n = Value at POR and BOR/Value at all other Resets

'1' = Bit is set

'0' = Bit is cleared

q = unchanged

bit 7-2      **Unimplemented:** Read as '0'

bit 1      **POR:** Power-on Reset Status bit

1 = No Power-on Reset occurred

0 = A Power-on Reset occurred (must be set in software after a Power-on Reset occurs)

bit 0      **BOR:** Brown-out Reset Status bit

1 = No Brown-out Reset occurred

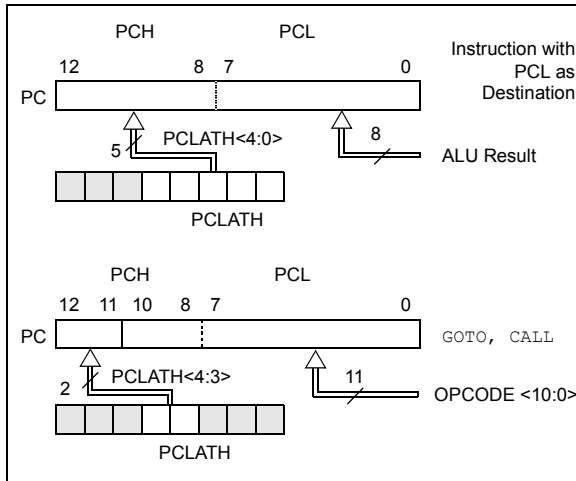
0 = A Brown-out Reset occurred (must be set in software after a Brown-out Reset occurs)



## 2.4 PCL and PCLATH

The Program Counter (PC) is 13 bits wide. The low byte comes from the PCL register, which is a readable and writable register. The high byte (PC<12:8>) is not directly readable or writable and comes from PCLATH. On any Reset, the PC is cleared. Figure 2-3 shows the two situations for the loading of the PC. The upper example in Figure 2-3 shows how the PC is loaded on a write to PCL (PCLATH<4:0> → PCH). The lower example in Figure 2-3 shows how the PC is loaded during a CALL or GOTO instruction (PCLATH<4:3> → PCH).

**FIGURE 2-3: LOADING OF PC IN DIFFERENT SITUATIONS**



### 2.4.1 MODIFYING PCL

Executing any instruction with the PCL register as the destination simultaneously causes the Program Counter PC<12:8> bits (PCH) to be replaced by the contents of the PCLATH register. This allows the entire contents of the program counter to be changed by writing the desired upper five bits to the PCLATH register. When the lower eight bits are written to the PCL register, all 13 bits of the program counter will change to the values contained in the PCLATH register and those being written to the PCL register.

A computed GOTO is accomplished by adding an offset to the program counter (ADDWF PCL). Care should be exercised when jumping into a look-up table or program branch table (computed GOTO) by modifying the PCL register. Assuming that PCLATH is set to the table start address, if the table length is greater than 255 instructions or if the lower eight bits of the memory address rolls over from 0xFF to 0x00 in the middle of the table, then PCLATH must be incremented for each address rollover that occurs between the table beginning and the target location within the table.

For more information refer to Application Note AN556, "Implementing a Table Read" (DS00556).

### 2.4.2 STACK

The PIC16F753/HV753 Family has an 8-level x 13-bit wide hardware stack (see Figure 2-1). The stack space is not part of either program or data space and the Stack Pointer is not readable or writable. The PC is PUSHed onto the stack when a CALL instruction is executed or an interrupt causes a branch. The stack is POPed in the event of a RETURN, RETLW or a RETFIE instruction execution. PCLATH is not affected by a PUSH or POP operation.

The stack operates as a circular buffer. This means that after the stack has been PUSHed eight times, the ninth push overwrites the value that was stored from the first push. The tenth push overwrites the second push (and so on).

- Note 1:** There are no Status bits to indicate Stack Overflow or Stack Underflow conditions.
- 2:** There are no instructions/mnemonics called PUSH or POP. These are actions that occur from the execution of the CALL, RETURN, RETLW and RETFIE instructions or the vectoring to an interrupt address.

## 2.5 Indirect Addressing, INDF and FSR Registers

The INDF register is not a physical register. Addressing the INDF register will cause indirect addressing.

Indirect addressing is possible by using the INDF register. Any instruction using the INDF register actually accesses data pointed to by the File Select Register (FSR). Reading INDF itself indirectly will produce 00h. Writing to the INDF register indirectly results in a no operation (although Status bits may be affected). An effective 9-bit address is obtained by concatenating the 8-bit FSR and the IRP bit of the STATUS register, as shown in Figure 2-4.

A simple program to clear RAM location 40h-7Fh using indirect addressing is shown in Example 2-1.

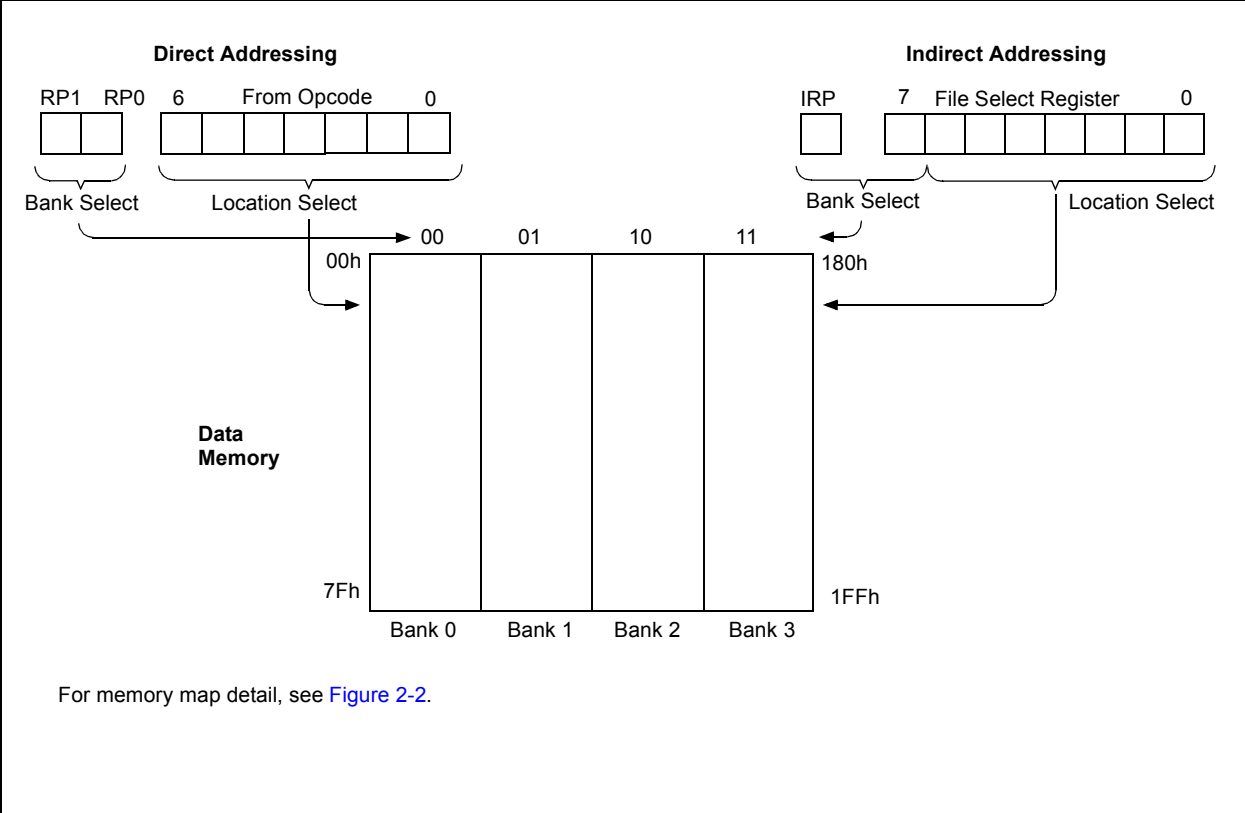
### EXAMPLE 2-1: INDIRECT ADDRESSING

```

MOV LW 0x40 ;initialize pointer
MOV WF FSR ;to RAM
NEXT CLRF INDF ;clear INDF register
INCF FSR ;inc pointer
BTFS FSR,7 ;all done?
GOTO NEXT ;no clear next
CONTINUE ;yes continue
    
```

# PIC16F753/HV753

**FIGURE 2-4: DIRECT/INDIRECT ADDRESSING PIC16F753/HV753**



## 3.0 FLASH PROGRAM MEMORY SELF READ/SELF WRITE CONTROL

The Flash program memory is readable and writable during normal operation (full VDD range). This memory is not directly mapped in the register file space. Instead, it is indirectly addressed through the Special Function Registers (see Registers 3-1 to 3-5). There are six SFRs used to read and write this memory:

- PMCON1
- PMCON2
- PMDATL
- PMDATH
- PMADRL
- PMADRH

When interfacing the program memory block, the PMDATL and PMDATH registers form a two-byte word which holds the 14-bit data for read/write, and the PMADRL and PMADRH registers form a two-byte word which holds the 10-bit address of the Flash location being accessed. These devices have 1K words of program Flash with an address range from 0000h to 03FFh.

The program memory allows a single-word read and a four-word write. A four-word write automatically erases the row of the location and writes the new data (erase before write).

The write time is controlled by an on-chip timer. The write/erase voltages are generated by an on-chip charge pump rated to operate over the voltage range of the device for byte or word operations.

When the device is code-protected, the CPU may continue to read and write the Flash program memory.

Depending on the settings of the Flash Program Memory Enable (WRT<1:0>) bits, the device may or may not be able to write certain blocks of the program memory; however, reads of the program memory are allowed.

When the Flash program memory Code Protection (CP) bit in the Configuration Word register is enabled, the program memory is code-protected, and the device programmer (ICSP™) cannot access data or program memory.

## 3.1 PMADRH and PMADRL Registers

The PMADRH and PMADRL registers can address up to a maximum of 1K words of program memory.

When selecting a program address value, the Most Significant Byte (MSB) of the address is written to the PMADRH register and the Least Significant Byte (LSB) is written to the PMADRL register.

## 3.2 PMCON1 and PMCON2 Registers

PMCON1 is the control register for the data program memory accesses.

Control bits RD and WR initiate read and write, respectively. These bits cannot be cleared, only set in software. They are cleared in hardware at completion of the read or write operation. The inability to clear the WR bit in software prevents the accidental premature termination of a write operation.

The WREN bit, when set, will allow a write operation. On power-up, the WREN bit is clear.

PMCON2 is not a physical register. Reading PMCON2 will read all '0's. The PMCON2 register is used exclusively in the Flash memory write sequence.

# PIC16F753/HV753

## 3.3 Register Definitions: Flash Program Memory Control

### REGISTER 3-1: PMDATL: PROGRAM MEMORY DATA LOW BYTE REGISTER

R/W-0	R/W-0	R/W-0	R/W-0	R/W-0	R/W-0	R/W-0	R/W-0
PMDATL<7:0>							
bit 7							bit 0

**Legend:**

R = Readable bit                      W = Writable bit                      U = Unimplemented bit, read as '0'  
 -n = Value at POR                      '1' = Bit is set                      '0' = Bit is cleared                      x = Bit is unknown

bit 7-0                      **PMDATL<7:0>**: Eight Least Significant Data bits to Write or Read from Program Memory

### REGISTER 3-2: PMADRL: PROGRAM MEMORY ADDRESS LOW BYTE REGISTER

R/W-0	R/W-0	R/W-0	R/W-0	R/W-0	R/W-0	R/W-0	R/W-0
PMADRL<7:0>							
bit 7							bit 0

**Legend:**

R = Readable bit                      W = Writable bit                      U = Unimplemented bit, read as '0'  
 -n = Value at POR                      '1' = Bit is set                      '0' = Bit is cleared                      x = Bit is unknown

bit 7-0                      **PMADRL<7:0>**: Eight Least Significant Address bits for Program Memory Read/Write Operation

### REGISTER 3-3: PMDATH: PROGRAM MEMORY DATA HIGH BYTE REGISTER

U-0	U-0	R/W-0	R/W-0	R/W-0	R/W-0	R/W-0	R/W-0
—	—	PMDATH<5:0>					
bit 7							bit 0

**Legend:**

R = Readable bit                      W = Writable bit                      U = Unimplemented bit, read as '0'  
 -n = Value at POR                      '1' = Bit is set                      '0' = Bit is cleared                      x = Bit is unknown

bit 7-6                      **Unimplemented:** Read as '0'

bit 5-0                      **PMDATH<5:0>**: Six Most Significant Data bits from Program Memory

### REGISTER 3-4: PMADRH: PROGRAM MEMORY ADDRESS HIGH BYTE REGISTER

U-0	U-0	U-0	U-0	U-0	U-0	R/W-0	R/W-0
—	—	—	—	—	—	PMADRH<1:0>	
bit 7							bit 0

**Legend:**

R = Readable bit                      W = Writable bit                      U = Unimplemented bit, read as '0'  
 -n = Value at POR                      '1' = Bit is set                      '0' = Bit is cleared                      x = Bit is unknown

bit 7-2                      **Unimplemented:** Read as '0'

bit 1-0                      **PMADRH<1:0>**: Specifies the two Most Significant Address bits or High bits for Program Memory Reads.

## REGISTER 3-5: PMCON1: PROGRAM MEMORY CONTROL 1 REGISTER

U-0	U-0	U-0	U-0	U-0	R/W-0/0	R/S/HC-0/0	R/S/HC-0/0
—	—	—	—	—	WREN	WR	RD
bit 7						bit 0	

### Legend:

R = Readable bit	W = Writable bit	U = Unimplemented bit, read as '0'
S = Bit can only be set	x = Bit is unknown	-n/n = Value at POR and BOR/Value at all other Resets
'1' = Bit is set	'0' = Bit is cleared	HC = Bit is cleared by hardware

bit 7-3 **Unimplemented:** Read as '0'

bit 2 **WREN:** Program/Erase Enable bit  
 1 = Allows program/erase cycles  
 0 = Inhibits programming/erasing of program Flash

bit 1 **WR:** Write Control bit  
 1 = Initiates a program Flash program/erase operation  
 The operation is self-timed and the bit is cleared by hardware once operation is complete.  
 The WR bit can only be set (not cleared) in software.  
 0 = Program/erase operation to the Flash is complete and inactive

bit 0 **RD:** Read Control bit  
 1 = Initiates a program Flash read. Read takes one cycle. RD is cleared in hardware. The RD bit can only be set (not cleared) in software.  
 0 = Does not initiate a program Flash read

## REGISTER 3-6: PMCON2: PROGRAM MEMORY CONTROL 2 REGISTER

W-0/0	W-0/0	W-0/0	W-0/0	W-0/0	W-0/0	W-0/0	W-0/0
Program Memory Control Register 2							
bit 7						bit 0	

### Legend:

R = Readable bit	W = Writable bit	U = Unimplemented bit, read as '0'
S = Bit can only be set	x = Bit is unknown	-n/n = Value at POR and BOR/Value at all other Resets
'1' = Bit is set	'0' = Bit is cleared	

bit 7-0 **Flash Memory Unlock Pattern bits:**  
 To unlock writes, a 55h must be written first, followed by an AAh, before setting the WR bit of the PMCON1 register. The value written to this register is used to unlock the writes. There are specific timing requirements on these writes.

# PIC16F753/HV753

---

## 3.4 Reading the Flash Program Memory

To read a program memory location, the user must write two bytes of the address to the PMADRL and PMADRH registers, and then set control bit RD (PMCON1<0>). Once the read control bit is set, the program memory Flash controller will use the second instruction cycle after to read the data. This causes the second instruction immediately following the “BSF PMCON1, RD” instruction to be ignored. The data is available in the very next cycle in the PMDATL and PMDATH registers; it can be read as two bytes in the following instructions. PMDATL and PMDATH registers will hold this value until another read or until it is written to by the user (during a write operation).

### EXAMPLE 3-1: FLASH PROGRAM READ

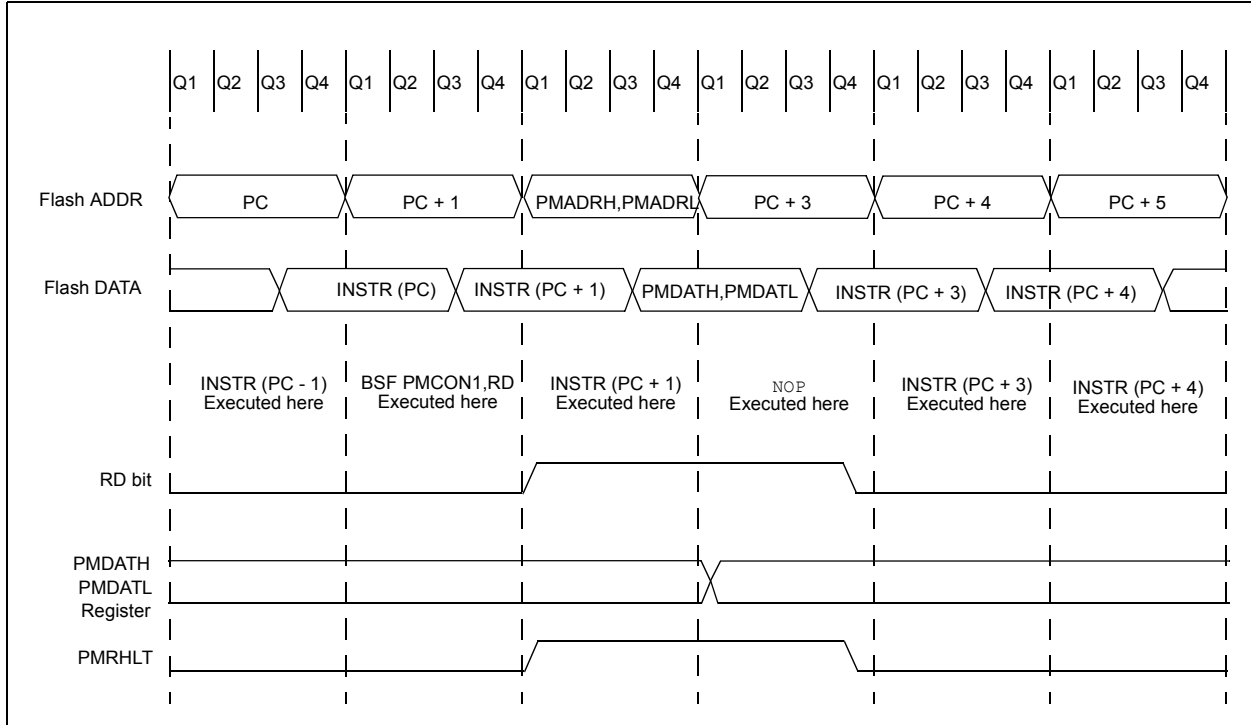
```
BANKSEL  PM_ADR           ; Change STATUS bits RP1:0 to select bank with PMADRL
MOVLW    MS_PROG_PM_ADDR ;
MOVWF    PMADRH          ; MS Byte of Program Address to read
MOVLW    LS_PROG_PM_ADDR ;
MOVWF    PMADRL          ; LS Byte of Program Address to read
BANKSEL  PMCON1          ; Bank to containing PMCON1
BSF      PMCON1, RD      ; PM Read

NOP                                             ; First instruction after BSF PMCON1,RD executes normally

NOP                                             ; Any instructions here are ignored as program
                                             ; memory is read in second cycle after BSF PMCON1,RD
                                             ;

BANKSEL  PMDATL          ; Bank to containing PMADRL
MOVF     PMDATL, W       ; W = LS Byte of Program PMDATL
MOVF     PMDATH, W       ; W = MS Byte of Program PMDATL
```

**FIGURE 3-1: FLASH PROGRAM MEMORY READ CYCLE EXECUTION**



# PIC16F753/HV753

---

## 3.5 Writing the Flash Program Memory

A word of the Flash program memory may only be written to if the word is in an unprotected segment of memory.

Flash program memory must be written in four-word blocks. See [Figure 3-2](#) and [Figure 3-3](#) for more details. A block consists of four words with sequential addresses, with a lower boundary defined by an address, where  $PMADRL<1:0> = 00$ . All block writes to program memory are done as 16-word erase by four-word write operations. The write operation is edge-aligned and cannot occur across boundaries.

To write program data, it must first be loaded into the buffer registers (see [Figure 3-2](#)). This is accomplished by first writing the destination address to PMADRL and PMADRH and then writing the data to PMDATL and PMDATH. After the address and data have been set up, then the following sequence of events must be executed:

1. Write 55h, then AAh, to PMCON2 (Flash programming sequence).
2. Set the WR control bit of the PMCON1 register.

All four buffer register locations should be written to with correct data. If less than four words are being written to in the block of four words, then a read from the program memory location(s) not being written to must be performed. This takes the data from the program location(s) not being written and loads it into the PMDATL and PMDATH registers. Then the sequence of events to transfer data to the buffer registers must be executed.

To transfer data from the buffer registers to the program memory, the PMADRL and PMADRH must point to the last location in the four-word block ( $PMADRL<1:0> = 11$ ). Then the following sequence of events must be executed:

1. Write 55h, then AAh, to PMCON2 (Flash programming sequence).
2. Set control bit WR of the PMCON1 register to begin the write operation.

The user must follow the same specific sequence to initiate the write for each word in the program block, writing each program word in sequence (000, 001, 010, 011). When the write is performed on the last word ( $PMADRL<1:0> = 11$ ), a block of sixteen words is automatically erased and the content of the four-word buffer registers are written into the program memory.

After the “BSF PMCON1, WR” instruction, the processor requires two cycles to set up the erase/write operation. The user must place two NOP instructions after the WR bit is set. Since data is being written to buffer registers, the writing of the first three words of the block appears to occur immediately. The processor will halt internal operations for the typical 4 ms, only during the cycle in

which the erase takes place (i.e., the last word of the sixteen-word block erase). This is not Sleep mode as the clocks and peripherals will continue to run. After the four-word write cycle, the processor will resume operation with the third instruction after the PMCON1 write instruction. The above sequence must be repeated for the higher 12 words.

## 3.6 Protection Against Spurious Write

There are conditions when the device should not write to the program memory. To protect against spurious writes, various mechanisms have been built in. On power-up, WREN is cleared. Also, the Power-up Timer (64 ms duration) prevents program memory writes.

The write initiate sequence and the WREN bit help prevent an accidental write during brown-out, power glitch or software malfunction.

## 3.7 Operation During Code-Protect

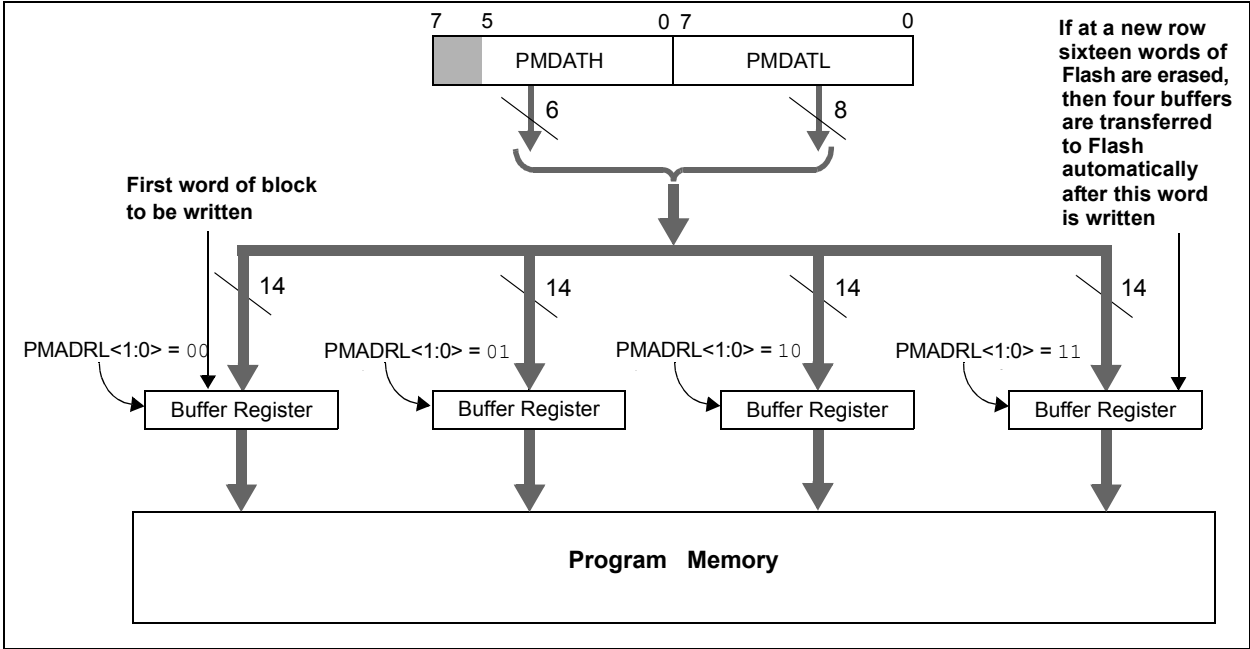
When the device is code-protected, the CPU is able to read and write unscrambled data to the program memory.

## 3.8 Operation During Write Protect

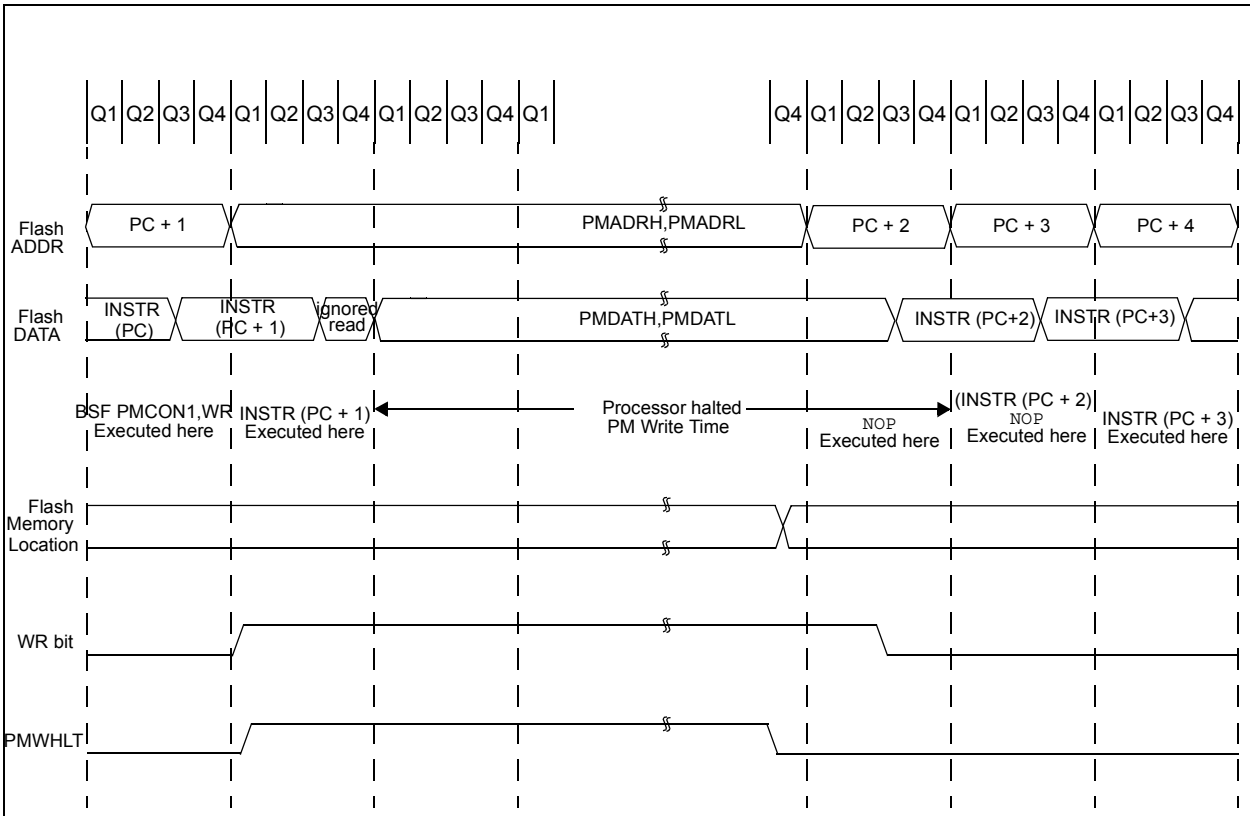
When the program memory is write-protected, the CPU can read and execute from the program memory. The portions of program memory that are write-protected can be modified by the CPU using the PMCON registers, but the protected program memory cannot be modified using ICSP mode.



**FIGURE 3-2: BLOCK WRITES TO 1K FLASH PROGRAM MEMORY**



**FIGURE 3-3: FLASH PROGRAM MEMORY LONG WRITE CYCLE EXECUTION**



# PIC16F753/HV753

An example of the complete four-word write sequence is shown in [Example 3-2](#). The initial address is loaded into the PMADRH and PMADRL register pair; the four words of data are loaded using indirect addressing.

## EXAMPLE 3-2: WRITING TO FLASH PROGRAM MEMORY

```
;/;;;;;;;;;;;;;;;;;;;;;;;;;;;;;;;;;;;;;;;;;;;;;;;;;;;;;;;;;;;;;;;;;;;;;;;;;;;;;;;;;/
; This write routine assumes the following:
;   A valid starting address (the least significant bits = '00')
;   is loaded in ADDRH:ADDRL
;   ADDRH, ADDRL and DATADDR are all located in data memory
;
BANKSEL          PMADRH
MOVF  ADDRH,W    ;Load initial address
MOVWF PMADRH    ;
MOVF  ADDRL,W   ;
MOVWF PMADRL    ;
MOVF  DATAADDR,W ;Load initial data address
MOVWF FSR      ;
LOOP MOVF INDF,W ;Load first data byte into lower
MOVWF PMDATL   ;
INCF  FSR,F    ;Next byte
MOVF  INDF,W   ;Load second data byte into upper
MOVWF PMDATH   ;
INCF  FSR,F    ;
BANKSEL PMCON1
BSF  PMCON1,WREN ;Enable writes
BCF  INTCON,GIE ;Disable interrupts (if using)
BTFSC INTCON,GIE ;See AN576
GOTO $-2
;/;;;;;;;;;;;;;;;;;;;;;;;;;;;;;;;;;;;;;;;;;;;;;;;;;;;;;;;;;;;;;;;;;;;;;;;;;;;;;;;;;/
; Required Sequence
MOVLW 55h      ;Start of required write sequence:
MOVWF PMCON2   ;Write 55h
MOVLW 0AAh    ;
MOVWF PMCON2   ;Write 0AAh
BSF  PMCON1,WR ;Set WR bit to begin write
NOP   ;Required to transfer data to the buffer
NOP   ;registers
;/;;;;;;;;;;;;;;;;;;;;;;;;;;;;;;;;;;;;;;;;;;;;;;;;;;;;;;;;;;;;;;;;;;;;;;;;;;;;;;;;;/
BCF  PMCON1,WREN ;Disable writes
BSF  INTCON,GIE  ;Enable interrupts (comment out if not using interrupts)
BANKSEL PMADRL
MOVF  PMADRL, W
INCF  PMADRL,F  ;Increment address
ANDLW 0x03     ;Indicates when sixteen words have been programmed
SUBLW 0x03     ;Change value for different size write blocks
;0x0F = 16 words
;0x0B = 12 words
;0x07 = 8 words
;0x03 = 4 words
BTFSS STATUS,Z ;Exit on a match,
GOTO  LOOP     ;Continue if more data needs to be written
```

**TABLE 3-1: SUMMARY OF REGISTERS ASSOCIATED WITH FLASH PROGRAM MEMORY**

Name	Bit 7	Bit 6	Bit 5	Bit 4	Bit 3	Bit 2	Bit 1	Bit 0	Register on Page
PMCON1	—	—	—	—	—	WREN	WR	RD	29
PMCON2	Program Memory Control Register 2								29
PMADRL	PMADRL<7:0>								28
PMADRH	—	—	—	—	—	—	PMADRH<1:0>		28
PMDATL	PMDATL<7:0>								28
PMDATH	—	—	PMDATH<5:0>						28
INTCON	GIE	PEIE	TOIE	INTE	IOCF	TOIF	INTF	IOCF	19

**Legend:** — = unimplemented location, read as '0'. Shaded cells are not used by Flash program memory module.

\* Page provides register information.

**TABLE 3-2: SUMMARY OF CONFIGURATION WORD WITH FLASH PROGRAM MEMORY**

Name	Bits	Bit -/7	Bit -/6	Bit 13/5	Bit 12/4	Bit 11/3	Bit 10/2	Bit 9/1	Bit 8/0	Register on Page
CONFIG <sup>(1)</sup>	13:8	—	—	DEBUG	CLKOUTEN	WRT<1:0>		BOREN<1:0>		162
	7:0	—	CP	MCLRE	PWRTE	WDTE	—	—	FOSC0	

**Legend:** — = unimplemented location, read as '1'. Shaded cells are not used by Flash program memory.

**Note 1:** See Configuration Word register ([Register 19-1](#)) for operation of all register bits.

# PIC16F753/HV753

---

NOTES:

## 4.0 OSCILLATOR MODULE

The internal oscillator module provides the following selectable system clock modes:

### 4.1 Overview

The oscillator module has a variety of clock sources and selection features that allow it to be used in a wide range of applications while maximizing performance and minimizing power consumption. Figure 4-1 illustrates a block diagram of the oscillator module.

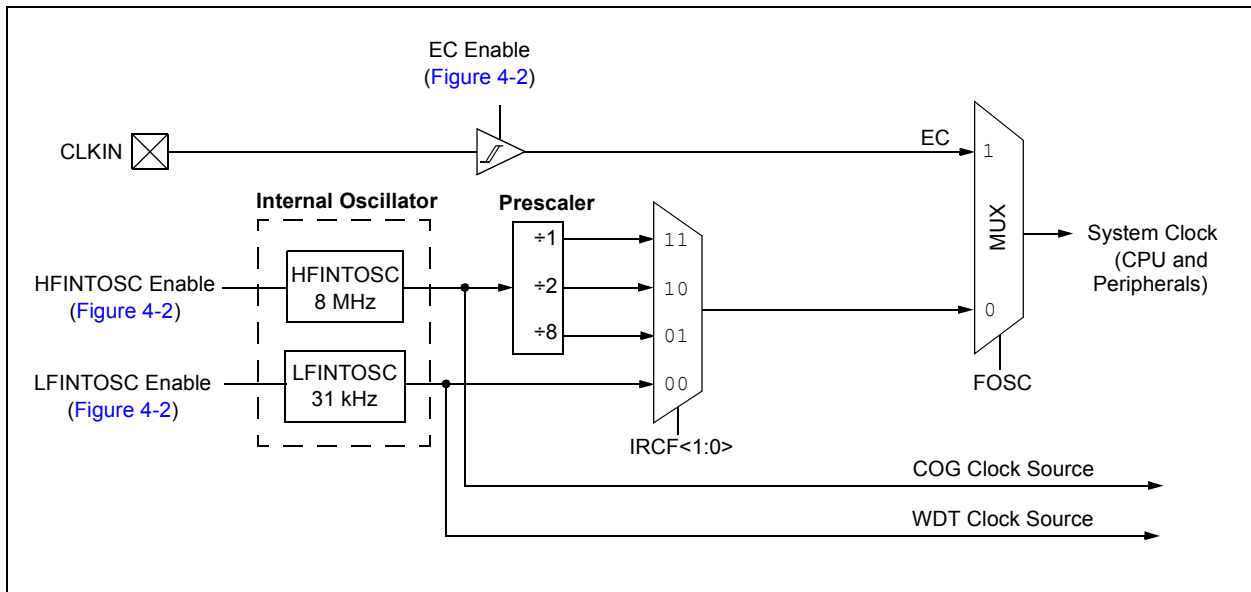
- 8 MHz (HFINTOSC)
- 4 MHz (HFINTOSC Postscaler)
- 1 MHz (HFINTOSC Postscaler)
- 31 kHz (LFINTOSC)

The oscillator module can be configured in one of two clock modes.

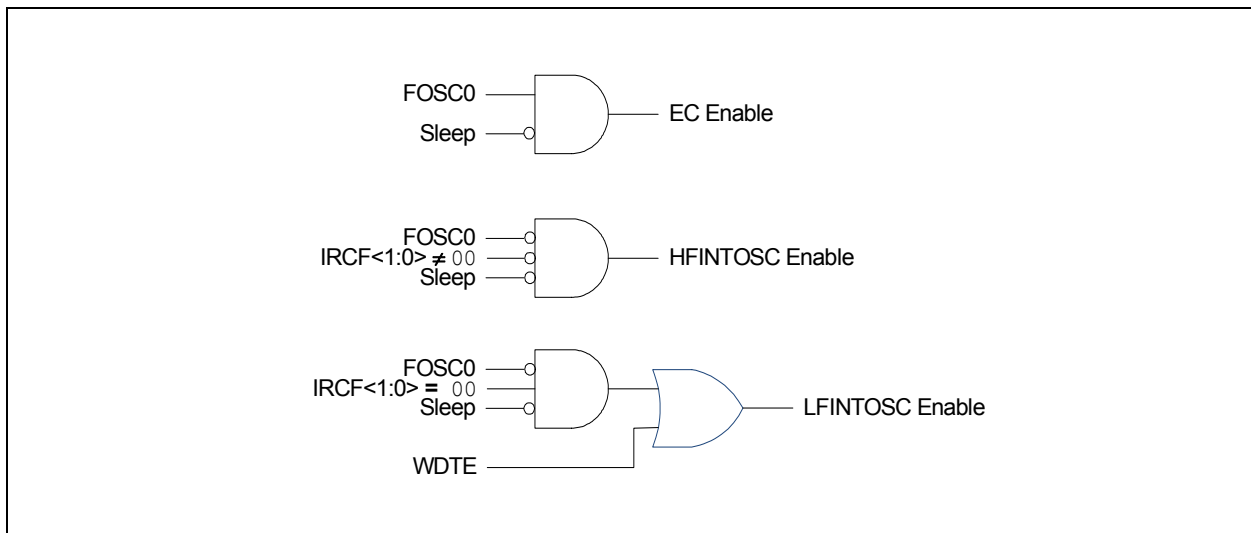
1. EC (external clock)
2. INTOSC (internal oscillator)

Clock Source modes are configured by the FOSC bit in the Configuration Word register (CONFIG).

**FIGURE 4-1: PIC® MCU CLOCK SOURCE BLOCK DIAGRAM**



**FIGURE 4-2: OSCILLATOR ENABLE**



# PIC16F753/HV753

## 4.2 Clock Source Modes

Clock Source modes can be classified as external or internal:

- The External Clock mode relies on an external clock for the clock source. For example, a clock module or clock output from another circuit.
- Internal clock sources are contained internally within the oscillator module. The oscillator module has four selectable clock frequencies:
  - 8 MHz
  - 4 MHz
  - 1 MHz
  - 31 kHz

The system clock can be selected between external or internal clock sources via the FOSC0 bit of the Configuration Word register (CONFIG).

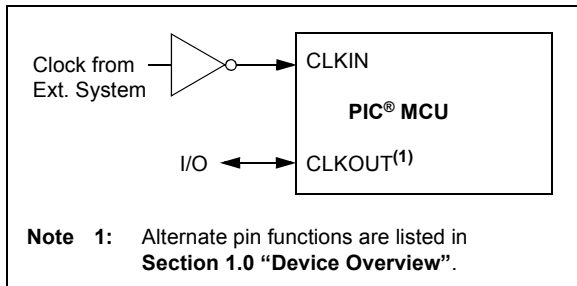
### 4.2.1 EC MODE

The External Clock (EC) mode allows an externally generated logic as the system clock source. The EC clock mode is selected when the FOSC0 bit of the Configuration Word is set.

When operating in this mode, an external clock source must be connected to the CLKIN input. The CLKOUT is available for either general purpose I/O or system clock output. [Figure 4-3](#) shows the pin connections for EC mode.

Because the PIC® MCU design is fully static, stopping the external clock input will have the effect of halting the device while leaving all data intact. Upon restarting the external clock, the device will resume operation as if no time had elapsed.

**FIGURE 4-3: EXTERNAL CLOCK (EC) MODE OPERATION**



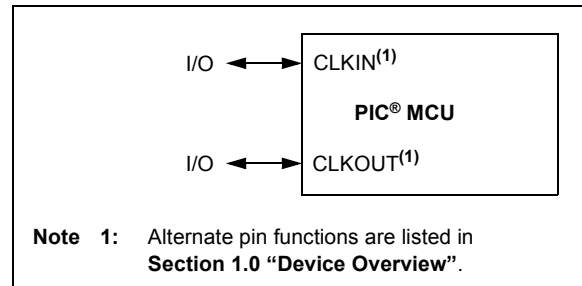
### 4.2.2 INTERNAL CLOCK MODE

Internal Clock mode configures the internal oscillators as the system clock source. The Internal Clock mode is selected when the FOSC0 bit of the Configuration Word is cleared. The source and frequency are selected with the IRCF<1:0> bits of the OSCCON register.

When one of the HFINTOSC frequencies is selected, the frequency of the internal oscillator can be trimmed by adjusting the TUN<4:0> bits of the OSTUNE register.

Operation after a Power-on Reset (POR) or wake-up from Sleep is delayed by the oscillator start-up time. Delays are typically longer for the LFINTOSC than HFINTOSC because of the very low-power operation and relatively narrow bandwidth of the LF internal oscillator. However, when another peripheral keeps the oscillator running during Sleep, the start-up time is delayed to allow the memory bias to stabilize.

**FIGURE 4-4: INTERNAL CLOCK MODE OPERATION**



#### 4.2.2.1 Oscillator Ready Bits

The HTS and LTS bits of the OSCCON register indicate the status of the HFINTOSC and LFINTOSC, respectively. When either bit is set, it indicates that the corresponding oscillator is running and stable.

## 4.3 System Clock Output

The CLKOUT pin is available for general purpose I/O or system clock output. The  $\overline{\text{CLKOUTEN}}$  bit of the Configuration Word controls the function of the CLKOUT pin.

When the  $\overline{\text{CLKOUTEN}}$  bit is cleared, the CLKOUT pin is driven by the selected internal oscillator frequency divided by 4. The corresponding I/O pin always reads '0' in this configuration.

The CLKOUT signal may be used to provide a clock for external circuitry, synchronization, calibration, test or other application requirements.

When the  $\overline{\text{CLKOUTEN}}$  bit is set, the system clock out function is disabled and the CLKOUT pin is available for general purpose I/O.

## 4.4 Oscillator Delay upon Wake-Up, Power-Up, and Base Frequency Change

In applications where the OSCTUNE register is used to shift the HFINTOSC frequency, the application should not expect the frequency to stabilize immediately. In this case, the frequency may shift gradually toward the new value. The time for this frequency shift is less than eight cycles of the base frequency.

A short delay is invoked upon power-up and when waking from sleep to allow the memory bias circuitry to stabilize. Table 4-1 shows examples where the oscillator delay is invoked.

**TABLE 4-1: OSCILLATOR DELAY EXAMPLES**

Switch From	Switch To	Frequency	Oscillator Delay
Sleep/POR	INTOSC	31 kHz to 8 MHz	10 $\mu\text{s}$ internal delay to allow memory bias to stabilize.
Sleep/POR	EC	DC – 20 MHz	

# PIC16F753/HV753

## 4.5 Register Definitions: Oscillator Control

REGISTER 4-1: OSCCON: OSCILLATOR CONTROL REGISTER

U-0	U-0	R/W-0/u	R/W-1/u	U-0	R-0/u	R-0/u	U-0
—	—	IRCF<1:0>		—	HTS	LTS	—
bit 7							bit 0

**Legend:**

R = Readable bit                      W = Writable bit                      U = Unimplemented bit, read as '0'  
-n = Value at POR                      '1' = Bit is set                      '0' = Bit is cleared                      x = Bit is unknown

- bit 7-6            **Unimplemented:** Read as '0'
- bit 5-4            **IRCF<1:0>:** Internal Oscillator Frequency Select bits
  - 11 = 8 MHz
  - 10 = 4 MHz
  - 01 = 1 MHz (Reset default)
  - 00 = 31 kHz (LFINTOSC)
- bit 3              **Unimplemented:** Read as '0'
- bit 2              **HTS:** HFINTOSC Status bit
  - 1 = HFINTOSC is stable
  - 0 = HFINTOSC is not stable
- bit 1              **LTS:** LFINTOSC Status bit
  - 1 = LFINTOSC is stable
  - 0 = LFINTOSC is not stable
- bit 0              **Unimplemented:** Read as '0'



## 4.5.1 OSCTUNE REGISTER

The oscillator is factory calibrated, but can be adjusted in software by writing to the OSCTUNE register ([Register 4-2](#)).

The default value of the OSCTUNE register is '0'. The value is a 5-bit two's complement number.

When the OSCTUNE register is modified, the frequency will begin shifting to the new frequency. Code execution continues during this shift. There is no indication that the shift has occurred.

### REGISTER 4-2: OSCTUNE: OSCILLATOR TUNING REGISTER

U-0	U-0	U-0	R/W-0/u	R/W-0/u	R/W-0/u	R/W-0/u	R/W-0/u
—	—	—	TUN<4:0>				
bit 7							bit 0

#### Legend:

R = Readable bit

W = Writable bit

U = Unimplemented bit, read as '0'

-n = Value at POR

'1' = Bit is set

'0' = Bit is cleared

x = Bit is unknown

bit 7-5 **Unimplemented:** Read as '0'

bit 4-0 **TUN<4:0>:** Frequency Tuning bits

01111 = Maximum frequency

01110 =

•

•

•

00001 =

00000 = Oscillator module is running at the calibrated frequency.

11111 =

•

•

•

10000 = Minimum frequency

**TABLE 4-2: SUMMARY OF REGISTERS ASSOCIATED WITH CLOCK SOURCES**

Name	Bit 7	Bit 6	Bit 5	Bit 4	Bit 3	Bit 2	Bit 1	Bit 0	Register on Page
OSCCON	—	—	IRCF<1:0>		—	HTS	LTS	—	40
OSCTUNE	—	—	—	TUN<4:0>					41

**Legend:** x = unknown, u = unchanged, - = unimplemented locations read as '0'. Shaded cells are not used by oscillators.

**TABLE 4-3: SUMMARY OF CONFIGURATION WORD CLOCK SOURCES**

Name	Bits	Bit -/7	Bit -/6	Bit 13/5	Bit 12/4	Bit 11/3	Bit 10/2	Bit 9/1	Bit 8/0	Register on Page
CONFIG <sup>(1)</sup>	13:8	—	—	DEBUG	CLKOUTEN	WRT<1:0>		BOREN<1:0>		162
	7:0	—	CP	MCLRE	PWRTE	WDTE	—	—	FOSC0	

**Legend:** — = unimplemented location, read as '1'. Shaded cells are not used by oscillator module.

**Note 1:** See Configuration Word register ([Register 19-1](#)) for operation of all register bits.

# PIC16F753/HV753

---

NOTES:

## 5.0 I/O PORTS

Depending on the device selected and peripherals enabled, there are up to two ports available. In general, when a peripheral is enabled, that pin may not be used as a general purpose I/O pin.

Each port has three standard registers for its operation.

These registers are:

- TRISx registers (data direction)
- PORTx registers (reads the levels on the pins of the device)
- LATx registers (output latch)

Some ports may have one or more of the following additional registers. These registers are:

- ANSELx (analog select)
- WPUx (weak pull-up)
- INLVx (input level control)

The Data Latch (LATx registers) is useful for read-modify-write operations on the values that the I/O pins are driving.

A write operation to the LATx register has the same affect as a write to the corresponding PORTx register. A read of the LATx register reads the values held in the I/O PORT latches, while a read of the PORTx register reads the actual I/O pin value.

Ports with analog functions also have an ANSELx register which can disable the digital input and save power. A simplified model of a generic I/O port, without the interfaces to other peripherals, is shown in Figure 5-1.

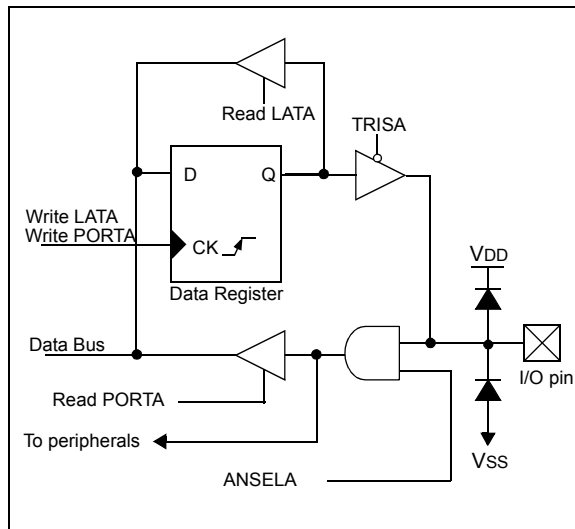
### EXAMPLE 5-1: INITIALIZING PORTA

```

; This code example illustrates
; initializing the PORTA register. The
; other ports are initialized in the same
; manner.

BANKSEL PORTA      ;
CLRF PORTA         ;Init PORTA
BANKSEL LATA       ;Data Latch
CLRF LATA          ;
BANKSEL ANSELA     ;
CLRF ANSELA       ;digital I/O
BANKSEL TRISA      ;
MOVLW B'00111000' ;Set RA<5:3> as inputs
MOVWF TRISA        ;and set RA<2:0> as
                   ;outputs
    
```

**FIGURE 5-1: GENERIC I/O PORTA OPERATION**



# PIC16F753/HV753

## 5.1 Alternate Pin Function

The Alternate Pin Function Control (APFCON) register is used to steer specific peripheral input and output functions between different pins. The APFCON register is shown in [Register 5-1](#). For this device family, the following functions can be moved between different pins.

- Timer1 Gate
- COG1

These bits have no effect on the values of any TRIS register. PORT and TRIS overrides will be routed to the correct pin. The unselected pin will be unaffected.

## 5.2 Register Definitions: Alternate Pin Function Control

**REGISTER 5-1: APFCON: ALTERNATE PIN FUNCTION CONTROL REGISTER**

U-0	U-0	U-0	R/W-0/0	U-0	U-0	U-0	U-0
—	—	—	T1GSEL	—	—	—	—
bit 7							bit 0

**Legend:**

R = Readable bit	W = Writable bit	U = Unimplemented bit, read as '0'
u = bit is unchanged	x = Bit is unknown	-n/n = Value at POR and BOR/Value at all other Resets
'1' = Bit is set	'0' = Bit is cleared	

- bit 7-5      **Unimplemented:** Read as '0'.
- bit 4      **T1GSEL:** Timer 1 Gate Input Pin Selection bit  
1 = T1G function is on RA3  
0 = T1G function is on RA4
- bit 3-0      **Unimplemented:** Read as '0'.

## 5.3 PORTA and TRISA Registers

PORTA is a 6-bit wide port with five bidirectional and one input-only pin. The corresponding data direction register is TRISA (Register 5-2). Setting a TRISA bit (= 1) will make the corresponding PORTA pin an input (i.e., disable the output driver). Clearing a TRISA bit (= 0) will make the corresponding PORTA pin an output (i.e., enables output driver and puts the contents of the output latch on the selected pin). The exception is RA3, which is input-only and its TRIS bit will always read as '1'. Example 5-1 shows how to initialize PORTA.

Reading the PORTA register (Register 5-2) reads the status of the pins, whereas writing to it will write to the PORT latch. All write operations are read-modify-write operations. Therefore, a write to a port implies that the port pins are read, this value is modified and then written to the PORT data latch. RA3 reads '0' when MCLR = 1.

The TRISA register controls the direction of the PORTA pins, even when they are being used as analog inputs. The user must ensure the bits in the TRISA register are maintained set when using them as analog inputs. I/O pins configured as analog input always read '0'.

**Note:** The ANSEL register must be initialized to configure an analog channel as a digital input. Pins configured as analog inputs will read '0' and cannot generate an interrupt.

### 5.3.1 PORTA FUNCTIONS AND OUTPUT PRIORITIES

Each PORTA pin is multiplexed with other functions. The pins, their combined functions and their output priorities are shown in Table 5-1.

When multiple outputs are enabled, the actual pin control goes to the peripheral with the highest priority.

Analog input functions, such as comparator inputs, are not shown in the priority lists. These inputs are active when the peripheral is enabled and the input multiplexer for the pin is selected. The Analog mode, set with the ANSELA register, disables the digital input buffer thereby preventing excessive input current when the analog input voltage is between logic states. Digital output functions may control the pin when it is in Analog mode with the priority shown in Table 5-1.

**TABLE 5-1: PORTA OUTPUT PRIORITY**

Pin Name	Function Priority
RA0	ICSPDAT FVROUT DACOUT C1IN0+ RA0
RA1	FVRIN ICSPCLK VREF C1IN0- C2IN0- RA1
RA2	COG1FLT T0CKI C1OUT INT RA2
RA3	MCLR VPP T1G RA3
RA4	CLKOUT T1G RA4
RA5	CLKIN T1CKI RA5

# PIC16F753/HV753

## 5.4 Register Definitions: PORTA Control

### REGISTER 5-2: PORTA: PORTA REGISTER

U-0	U-0	R/W-x/u	R/W-x/u	R-x/x	R/W-x/u	R/W-x/u	R/W-x/u
—	—	RA5	RA4	RA3	RA2	RA1	RA0
bit 7							bit 0

#### Legend:

R = Readable bit                      W = Writable bit                      U = Unimplemented bit, read as '0'  
u = Bit is unchanged                      x = Bit is unknown                      -n/n = Value at POR and BOR/Value at all other Resets  
'1' = Bit is set                              '0' = Bit is cleared

bit 7-6                      **Unimplemented:** Read as '0'  
bit 5-0                      **RA<5:0>:** PORTA I/O Value bits<sup>(1)</sup>  
                                    1 = Port pin is  $\geq V_{IH}$   
                                    0 = Port pin is  $\leq V_{IL}$

**Note 1:** Writes to PORTA are actually written to corresponding LATA register. Reads from PORTA register is return of actual I/O pin values.

### REGISTER 5-3: TRISA: PORTA TRI-STATE REGISTER

U-0	U-0	R/W-1/1	R/W-1/1	R-1/1	R/W-1/1	R/W-1/1	R/W-1/1
—	—	TRISA5	TRISA4	TRISA3 <sup>(1)</sup>	TRISA2	TRISA1	TRISA0
bit 7							bit 0

#### Legend:

R = Readable bit                      W = Writable bit                      U = Unimplemented bit, read as '0'  
u = Bit is unchanged                      x = Bit is unknown                      -n/n = Value at POR and BOR/Value at all other Resets  
'1' = Bit is set                              '0' = Bit is cleared

bit 7-6                      **Unimplemented:** Read as '0'  
bit 5-0                      **TRISA<5:0>:** PORTA Tri-State Control bits<sup>(1)</sup>  
                                    1 = PORTA pin configured as an input (tri-stated)  
                                    0 = PORTA pin configured as an output

**Note 1:** TRISA3 always reads '1'.

### REGISTER 5-4: LATA: PORTA DATA LATCH REGISTER

U-0	U-0	R/W-x/u	R/W-x/u	U-0	R/W-x/u	R/W-x/u	R/W-x/u
—	—	LATA5	LATA4	—	LATA2	LATA1	LATA0
bit 7							bit 0

#### Legend:

R = Readable bit                      W = Writable bit                      U = Unimplemented bit, read as '0'  
u = Bit is unchanged                      x = Bit is unknown                      -n/n = Value at POR and BOR/Value at all other Resets  
'1' = Bit is set                              '0' = Bit is cleared

bit 7-6                      **Unimplemented:** Read as '0'  
bit 5-4                      **LATA<5:4>:** PORTA Output Latch Value bits<sup>(1)</sup>  
bit 3                              **Unimplemented:** Read as '0'  
bit 2-0                      **LATA<2:0>:** PORTA Output Latch Value bits<sup>(1)</sup>

**Note 1:** Writes to PORTA are actually written to corresponding LATA register. Reads from PORTA register is return of actual I/O pin values.

## 5.5 Additional Pin Functions

Every PORTA pin on the PIC16F753 has an interrupt-on-change option and a weak pull-up option. The next three sections describe these functions.

### 5.5.1 ANSELA REGISTER

The ANSELA register ([Register 5-5](#)) is used to configure the Input mode of an I/O pin to analog. Setting the appropriate ANSELA bit high will cause all digital reads on the pin to be read as '0' and allow analog functions on the pin to operate correctly.

The state of the ANSELA bits has no effect on digital output functions. A pin with TRIS clear and ANSEL set will still operate as a digital output, but the Input mode will be analog. This can cause unexpected behavior when executing read-modify-write instructions on the affected port.

**Note:** The ANSELA bits default to the Analog mode after Reset. To use any pins as digital general purpose or peripheral inputs, the corresponding ANSEL bits must be initialized to '0' by user software.

### 5.5.2 WEAK PULL-UPS

Each of the PORTA pins, except RA3, has an individually configurable internal weak pull-up. Control bits WPUx enable or disable each pull-up. Refer to [Register 5-6](#). Each weak pull-up is automatically turned off when the port pin is configured as an output. The pull-ups are disabled on a Power-on Reset by the RPU bit of the OPTION\_REG register. A weak pull-up is automatically enabled for RA3 when configured as MCLR and disabled when RA3 is an I/O. There is no software control of the MCLR pull-up.

### 5.5.3 INTERRUPT-ON-CHANGE

Each PORTA pin is individually configurable as an interrupt-on-change pin. Control bits IOCA enable or disable the interrupt function for each pin. Refer to [Register 5-7](#). The interrupt-on-change is disabled on a Power-on Reset.

For enabled interrupt-on-change pins, the values are compared with the old value latched on the last read of PORTA. The 'mismatch' outputs of the last read are OR'd together to set the PORTA Change Interrupt Flag bit (IOCIF) in the INTCON register ([Register 2-3](#)).

This interrupt can wake the device from Sleep. The user, in the Interrupt Service Routine, clears the interrupt by:

- a) Any read of PORTA AND Clear flag bit IOCIF.  
This will end the mismatch condition;
- OR
- b) Any write of PORTA AND Clear flag bit IOCIF  
will end the mismatch condition;

A mismatch condition will continue to set flag bit IOCIF. Reading PORTA will end the mismatch condition and allow flag bit IOCIF to be cleared. The latch holding the last read value is not affected by a MCLR nor BOR Reset. After these Resets, the IOCIF flag will continue to be set if a mismatch is present.

**Note:** If a change on the I/O pin should occur when any PORTA operation is being executed, then the IOCIF interrupt flag may not get set.

### 5.5.4 SLEW RATE CONTROL

Two of the PORTA pins, RA0 and RA2, are equipped with high current driver circuitry. The SLRCONA register provides reduced slew rate control to mitigate possible EMI radiation from these pins.

# PIC16F753/HV753

## REGISTER 5-5: ANSELA: PORTA ANALOG SELECT REGISTER

U-0	U-0	U-0	R/W-1	U-0	R/W-1	R/W-1	R/W-1
—	—	—	ANSA4	—	ANSA2	ANSA1	ANSA0
bit 7							bit 0

### Legend:

R = Readable bit                      W = Writable bit                      U = Unimplemented bit, read as '0'  
 -n = Value at POR                      '1' = Bit is set                      '0' = Bit is cleared                      x = Bit is unknown

- bit 7-5                      **Unimplemented:** Read as '0'
- bit 4                      ANSA4: Analog Select Between Analog or Digital Function on Pin RA4 bit  
 1 = Analog input. Pin is assigned as analog input<sup>(1)</sup>.  
 0 = Digital I/O. Pin is assigned to port or special function.
- bit 3                      **Unimplemented:** Read as '0'
- bit 2-0                      ANSA<2:0> Analog Select Between Analog or Digital Function on Pin RA<2:0> bits  
 1 = Analog input. Pin is assigned as analog input.<sup>(1)</sup>  
 0 = Digital I/O. Pin is assigned to port or special function.

**Note 1:** Setting a pin to an analog input automatically disables the digital input circuitry, weak pull-ups, and interrupt-on-change if available. The corresponding TRIS bit must be set to Input mode in order to allow external control of the voltage on the pin.

## REGISTER 5-6: WPUA: WEAK PULL-UP PORTA REGISTER

U-0	U-0	R/W-1	R/W-1	R/W-1	R/W-1	R/W-1	R/W-1
—	—	WPUA5	WPUA4	WPUA3	WPUA2	WPUA1	WPUA0
bit 7							bit 0

### Legend:

R = Readable bit                      W = Writable bit                      U = Unimplemented bit, read as '0'  
 -n = Value at POR                      '1' = Bit is set                      '0' = Bit is cleared                      x = Bit is unknown

- bit 7-6                      **Unimplemented:** Read as '0'
- bit 5-0                      **WPUA<5:0>:** Weak Pull-up Control bits<sup>(1,2,3)</sup>  
 1 = Pull-up enabled  
 0 = Pull-up disabled

**Note 1:** Global  $\overline{\text{RAPU}}$  must be enabled for individual pull-ups to be enabled.  
**Note 2:** The weak pull-up device is automatically disabled if the pin is in Output mode (TRISA = 0).  
**Note 3:** The RA3 pull-up is enabled when configured as  $\overline{\text{MCLR}}$  in the Configuration Word, otherwise it is disabled as an input and reads as '0'.



## REGISTER 5-7: IOCAP: INTERRUPT-ON-CHANGE POSITIVE EDGE REGISTER

U-0	U-0	R/W-0/0	R/W-0/0	R/W-0/0	R/W-0/0	R/W-0/0	R/W-0/0
—	—	IOCAP5	IOCAP4	IOCAP3	IOCAP2	IOCAP1	IOCAP0
bit 7							bit 0

### Legend:

R = Readable bit                      W = Writable bit                      U = Unimplemented bit, read as '0'  
u = Bit is unchanged                      x = Bit is unknown                      -n/n = Value at POR and BOR/Value at all other Resets  
'1' = Bit is set                              '0' = Bit is cleared

bit 7-6                      **Unimplemented:** Read as '0'

bit 5-0                      **IOCAP<5:0>:** Interrupt-on-Change Positive Edge Enable bits

- 1 = Interrupt-on-Change enabled on the pin for a positive going edge. Associated Status bit and interrupt flag will be set upon detecting an edge.
- 0 = Interrupt-on-Change disabled for the associated pin.

## REGISTER 5-8: IOCAN: INTERRUPT-ON-CHANGE NEGATIVE EDGE REGISTER

U-0	U-0	R/W-0/0	R/W-0/0	R/W-0/0	R/W-0/0	R/W-0/0	R/W-0/0
—	—	IOCAN5	IOCAN4	IOCAN3	IOCAN2	IOCAN1	IOCAN0
bit 7							bit 0

### Legend:

R = Readable bit                      W = Writable bit                      U = Unimplemented bit, read as '0'  
u = Bit is unchanged                      x = Bit is unknown                      -n/n = Value at POR and BOR/Value at all other Resets  
'1' = Bit is set                              '0' = Bit is cleared

bit 7-6                      **Unimplemented:** Read as '0'

bit 5-0                      **IOCAN<5:0>:** Interrupt-on-Change Negative Edge Enable bits

- 1 = Interrupt-on-Change enabled on the pin for a negative going edge. Associated Status bit and interrupt flag will be set upon detecting an edge.
- 0 = Interrupt-on-Change disabled for the associated pin.

## REGISTER 5-9: IOCAF: INTERRUPT-ON-CHANGE FLAG REGISTER

U-0	U-0	R/W/HS-0/0	R/W/HS-0/0	R/W/HS-0/0	R/W/HS-0/0	R/W/HS-0/0	R/W/HS-0/0
—	—	IOCAF5	IOCAF4	IOCAF3	IOCAF2	IOCAF1	IOCAF0
bit 7							bit 0

### Legend:

R = Readable bit                      W = Writable bit                      U = Unimplemented bit, read as '0'  
u = Bit is unchanged                      x = Bit is unknown                      -n/n = Value at POR and BOR/Value at all other Resets  
'1' = Bit is set                              '0' = Bit is cleared                      HS - Bit is set in hardware

bit 7-6                      **Unimplemented:** Read as '0'

bit 5-0                      **IOCAF<5:0>:** Interrupt-on-Change Flag bits

- 1 = An enabled change was detected on the associated pin.  
Set when IOCAPx = 1 and a rising edge was detected on RBx, or when IOCANx = 1 and a falling edge was detected on RAx.
- 0 = No change was detected, or the user cleared the detected change.

# PIC16F753/HV753

**TABLE 5-2: SUMMARY OF REGISTERS ASSOCIATED WITH PORTA**

Name	Bit 7	Bit 6	Bit 5	Bit 4	Bit 3	Bit 2	Bit 1	Bit 0	Register on Page
ADCON0	ADFM	—	CHS<3:0>			—	GO/DONE	ADON	118
ADCON1	—	ADCS<2:0>			—	—	—	ADPREF1	119
ANSELA	—	—	—	ANSA4	—	ANSA2	ANSA1	ANSA0	48
APFCON	—	—	—	T1GSEL	—	—	—	—	44
CM1CON0	C1ON	C1OUT	C1OE	C1POL	C1ZLF	C1SP	C1HYS	C1SYNC	139
CM2CON0	C2ON	C2OUT	C2OE	C2POL	C2ZLF	C2SP	C2HYS	C2SYNC	139
CM1CON1	C1INTP	C1INTN	C1PCH<2:0>			C1NCH<2:0>			140
CM2CON1	C2INTP	C2INTN	C2PCH<2:0>			C2NCH<2:0>			140
DAC1CON0	DACEN	DACFM	DACOE	—	DACPSS1	DACPSS0	—	—	130
IOCAF	—	—	IOCAF5	IOCAF4	IOCAF3	IOCAF2	IOCAF1	IOCAF0	49
IOCAN	—	—	IOCAN5	IOCAN4	IOCAN3	IOCAN2	IOCAN1	IOCAN0	49
IOCAP	—	—	IOCAP5	IOCAP4	IOCAP3	IOCAP2	IOCAP1	IOCAP0	49
LATA	—	—	LATA5	LATA4	—	LATA2	LATA1	LATA0	46
OPTION_REG	RAPU	INTEDG	T0CS	T0SE	PSA	PS<2:0>			18
PORTA	—	—	RA5	RA4	RA3	RA2	RA1	RA0	46
SLRCONC	—	—	SLRC5	SLRC4	—	—	—	—	54
TRISA	—	—	TRISA5	TRISA4	TRISA3 <sup>(1)</sup>	TRISA2	TRISA1	TRISA0	46

**Legend:** x = unknown, u = unchanged, — = unimplemented locations read as '0'. Shaded cells are not used by PORTA.

**Note 1:** TRISA3 always reads '1'.

## 5.6 PORTC Registers

PORTC is a 6-bit wide port with five bidirectional and one input-only pin. The corresponding data direction register is TRISC (Register 5-2). Setting a TRISC bit (= 1) will make the corresponding PORTC pin an input (i.e., disable the output driver). Clearing a TRISC bit (= 0) will make the corresponding PORTC pin an output (i.e., enables output driver and puts the contents of the output latch on the selected pin). The exception is RA3, which is input-only and its TRIS bit will always read as '1'. Example 5-1 shows how to initialize PORTC.

Reading the PORTC register (Register 5-2) reads the status of the pins, whereas writing to it will write to the PORT latch. All write operations are read-modify-write operations. Therefore, a write to a port implies that the port pins are read, this value is modified and then written to the PORT data latch. RC3 reads '0' when MCLRE = 1.

The TRISC register controls the direction of the PORTC pins, even when they are being used as analog inputs. The user must ensure the bits in the TRISC register are maintained set when using them as analog inputs. I/O pins configured as analog input always read '0'.

**Note:** The ANSEL register must be initialized to configure an analog channel as a digital input. Pins configured as analog inputs will read '0' and cannot generate an interrupt.

### 5.6.1 PORTC FUNCTIONS AND OUTPUT PRIORITIES

Each PORTC pin is multiplexed with other functions. The pins, their combined functions and their output priorities are shown in Table 5-1.

When multiple outputs are enabled, the actual pin control goes to the peripheral with the highest priority.

Analog input functions, such as comparator inputs, are not shown in the priority lists. These inputs are active when the peripheral is enabled and the input multiplexer for the pin is selected. The Analog mode, set with the ANSEL register, disables the digital input buffer thereby preventing excessive input current when the analog input voltage is between logic states. Digital output functions may control the pin when it is in Analog mode with the priority shown in Table 5-1.

**TABLE 5-3: PORTC OUTPUT PRIORITY**

Pin Name	Function Priority
RC0	OPA1IN+ C2IN0+ RC0
RC1	OPA1IN- C1IN1- C2IN1- RC1
RC2	SLPCIN OPA1OUT C1IN2- C2IN2- RC2
RC3	C1IN3- C2IN3- RC3
RC4	COG1OUT1 C2OUT RC4
RC5	COG1OUT0 CCP1 RC5

## 5.7 PORTC Control Registers

**REGISTER 5-10: PORTC: PORTC REGISTER**

U-0	U-0	R/W-x/u	R/W-x/u	R-x/x	R/W-x/u	R/W-x/u	R/W-x/u
—	—	RC5	RC4	RC3	RC2	RC1	RC0
bit 7							bit 0

**Legend:**

R = Readable bit	W = Writable bit	U = Unimplemented bit, read as '0'
u = Bit is unchanged	x = Bit is unknown	-n/n = Value at POR and BOR/Value at all other Resets
'1' = Bit is set	'0' = Bit is cleared	

bit 7-6      **Unimplemented:** Read as '0'

bit 5-0      **RC<5:0>:** PORTC I/O Value bits<sup>(1)</sup>  
                   1 = Port pin is  $\geq V_{IH}$   
                   0 = Port pin is  $\leq V_{IL}$

**Note 1:** Writes to PORTC are actually written to corresponding LATC register. Reads from PORTC register is return of actual I/O pin values.

# PIC16F753/HV753

## REGISTER 5-11: TRISC: PORTC TRI-STATE REGISTER

U-0	U-0	R/W-1/1	R/W-1/1	R-1/1	R/W-1/1	R/W-1/1	R/W-1/1
—	—	TRISC5	TRISC4	TRISC3 <sup>(1)</sup>	TRISC2	TRISC1	TRISC0
bit 7							bit 0

### Legend:

R = Readable bit                      W = Writable bit                      U = Unimplemented bit, read as '0'  
u = Bit is unchanged                      x = Bit is unknown                      -n/n = Value at POR and BOR/Value at all other Resets  
'1' = Bit is set                              '0' = Bit is cleared

bit 7-6                      **Unimplemented:** Read as '0'  
bit 5-0                      **TRISC<5:0>:** PORTC Tri-State Control bits<sup>(1)</sup>  
                                    1 = PORTC pin configured as an input (tri-stated)  
                                    0 = PORTC pin configured as an output

**Note 1:** TRISC3 always reads '1'.

## REGISTER 5-12: LATC: PORTC DATA LATCH REGISTER

U-0	U-0	R/W-x/u	R/W-x/u	U-0	R/W-x/u	R/W-x/u	R/W-x/u
—	—	LATC5	LATC4	—	LATC2	LATC1	LATC0
bit 7							bit 0

### Legend:

R = Readable bit                      W = Writable bit                      U = Unimplemented bit, read as '0'  
u = Bit is unchanged                      x = Bit is unknown                      -n/n = Value at POR and BOR/Value at all other Resets  
'1' = Bit is set                              '0' = Bit is cleared

bit 7-6                      **Unimplemented:** Read as '0'  
bit 5-4                      **LATC<5:4>:** PORTC Output Latch Value bits<sup>(1)</sup>  
bit 3                              **Unimplemented:** Read as '0'  
bit 2-0                      **LATC<2:0>:** PORTC Output Latch Value bits<sup>(1)</sup>

**Note 1:** Writes to PORTC are actually written to corresponding LATC register. Reads from PORTC register is return of actual I/O pin values.

## 5.8 Additional Pin Functions

Every PORTC pin on the PIC16F753 has an interrupt-on-change option and a weak pull-up option. The next three sections describe these functions.

### 5.8.1 ANSEL REGISTER

The ANSEL register ([Register 5-5](#)) is used to configure the Input mode of an I/O pin to analog. Setting the appropriate ANSEL bit high will cause all digital reads on the pin to be read as '0' and allow analog functions on the pin to operate correctly.

The state of the ANSEL bits has no effect on digital output functions. A pin with TRIS clear and ANSEL set will still operate as a digital output, but the Input mode will be analog. This can cause unexpected behavior when executing read-modify-write instructions on the affected port.

**Note:** The ANSEL bits default to the Analog mode after Reset. To use any pins as digital general purpose or peripheral inputs, the corresponding ANSEL bits must be initialized to '0' by user software.

### 5.8.2 WEAK PULL-UPS

Each of the PORTC pins, except RC3, has an individually configurable internal weak pull-up. Control bits WPUx enable or disable each pull-up. Refer to [Register 5-6](#). Each weak pull-up is automatically turned off when the port pin is configured as an output. The pull-ups are disabled on a Power-on Reset by the RAPU bit of the OPTION\_REG register. A weak pull-up is automatically enabled for RC3 when configured as MCLR and disabled when RC3 is an I/O. There is no software control of the MCLR pull-up.

### 5.8.3 INTERRUPT-ON-CHANGE

Each PORTC pin is individually configurable as an interrupt-on-change pin. Control bit IOCC enables or disables the interrupt function for each pin. Refer to [Register 5-7](#). The interrupt-on-change is disabled on a Power-on Reset.

For enabled interrupt-on-change pins, the values are compared with the old value latched on the last read of PORTC. The 'mismatch' outputs of the last read are OR'd together to set the PORTC Change Interrupt Flag bit (IOCIF) in the INTCON register ([Register 2-3](#)).

This interrupt can wake the device from Sleep. The user, in the Interrupt Service Routine, clears the interrupt by:

- a) Any read of PORTC AND Clear flag bit IOCIF.  
This will end the mismatch condition;
- OR
- b) Any write of PORTC AND Clear flag bit IOCIF  
will end the mismatch condition;

A mismatch condition will continue to set flag bit IOCIF. Reading PORTC will end the mismatch condition and allow flag bit IOCIF to be cleared. The latch holding the last read value is not affected by a MCLR nor BOR Reset. After these Resets, the IOCIF flag will continue to be set if a mismatch is present.

**Note:** If a change on the I/O pin should occur when any PORTC operation is being executed, then the IOCIF interrupt flag may not get set.

### 5.8.4 SLEW RATE CONTROL

Two of the PORTC pins, RC4 and RC5, are equipped with high current driver circuitry. The SLRCONC register provides reduced slew rate control to mitigate possible EMI radiation from these pins.

# PIC16F753/HV753

## REGISTER 5-13: SLRCONC: SLEW RATE CONTROL REGISTER

U-0	U-0	R/W-1/1	R/W-1/1	U-0	U-0	U-0	U-0
—	—	SLRC5	SLRC4	—	—	—	—
bit 7							bit 0

### Legend:

R = Readable bit                      W = Writable bit                      U = Unimplemented bit, read as '0'  
-n = Value at POR                      '1' = Bit is set                      '0' = Bit is cleared                      x = Bit is unknown

bit 7-6                      **Unimplemented:** Read as '0'  
bit 5-4                      **SLRC<5:4>:** Slew Rate Control Register bit  
                                    1 = Slew rate control enabled  
                                    0 = Slew rate control disabled  
bit 3-0                      **Unimplemented:** Read as '0'

## REGISTER 5-14: ANSELC: PORTC ANALOG SELECT REGISTER

U-0	U-0	U-0	U-0	R/W-1	R/W-1	R/W-1	R/W-1
—	—	—	—	ANSC3	ANSC2	ANSC1	ANSC0
bit 7							bit 0

### Legend:

R = Readable bit                      W = Writable bit                      U = Unimplemented bit, read as '0'  
-n = Value at POR                      '1' = Bit is set                      '0' = Bit is cleared                      x = Bit is unknown

bit 7-4                      **Unimplemented:** Read as '0'  
bit 3-0                      **ANSC<3:0>:** Analog Select Between Analog or Digital Function on Pin RC<3:0> bits  
                                    1 = Analog input. Pin is assigned as analog input.<sup>(1)</sup>  
                                    0 = Digital I/O. Pin is assigned to port or special function.

**Note 1:** Setting a pin to an analog input automatically disables the digital input circuitry, weak pull-ups, and interrupt-on-change if available. The corresponding TRIS bit must be set to Input mode in order to allow external control of the voltage on the pin.

## REGISTER 5-15: WPUC: WEAK PULL-UP PORTC REGISTER

U-0	U-0	R/W-1	R/W-1	R/W-1	R/W-1	R/W-1	R/W-1
—	—	WPUC5	WPUC4	WPUC3	WPUC2	WPUC1	WPUC0
bit 7							bit 0

### Legend:

R = Readable bit                      W = Writable bit                      U = Unimplemented bit, read as '0'  
 -n = Value at POR                      '1' = Bit is set                      '0' = Bit is cleared                      x = Bit is unknown

bit 7-6                      **Unimplemented:** Read as '0'  
 bit 5-0                      **WPUC<5:0>:** Weak Pull-up Control bits<sup>(1,2,3)</sup>  
                                     1 = Pull-up enabled  
                                     0 = Pull-up disabled

- Note 1:** Global  $\overline{\text{RAPU}}$  must be enabled for individual pull-ups to be enabled.  
**Note 2:** The weak pull-up device is automatically disabled if the pin is in Output mode ( $\text{TRISC} = 0$ ).  
**Note 3:** The RC3 pull-up is enabled when configured as  $\overline{\text{MCLR}}$  in the Configuration Word, otherwise it is disabled as an input and reads as '0'.

## REGISTER 5-16: IOCCP: INTERRUPT-ON-CHANGE POSITIVE EDGE REGISTER

U-0	U-0	R/W-0/0	R/W-0/0	R/W-0/0	R/W-0/0	R/W-0/0	R/W-0/0
—	—	IOCCP5	IOCCP4	IOCCP3	IOCCP2	IOCCP1	IOCCP0
bit 7							bit 0

### Legend:

R = Readable bit                      W = Writable bit                      U = Unimplemented bit, read as '0'  
 u = Bit is unchanged                      x = Bit is unknown                      -n/n = Value at POR and BOR/Value at all other Resets  
 '1' = Bit is set                      '0' = Bit is cleared

bit 7-6                      **Unimplemented:** Read as '0'  
 bit 5-0                      **IOCCP<5:0>:** Interrupt-on-Change Positive Edge Enable bits  
                                     1 = Interrupt-on-Change enabled on the pin for a positive going edge. Associated Status bit and interrupt flag will be set upon detecting an edge.  
                                     0 = Interrupt-on-Change disabled for the associated pin.

# PIC16F753/HV753

## REGISTER 5-17: IOCCN: INTERRUPT-ON-CHANGE NEGATIVE EDGE REGISTER

U-0	U-0	R/W-0/0	R/W-0/0	R/W-0/0	R/W-0/0	R/W-0/0	R/W-0/0
—	—	IOCCN5	IOCCN4	IOCCN3	IOCCN2	IOCCN1	IOCCN0
bit 7							bit 0

### Legend:

R = Readable bit	W = Writable bit	U = Unimplemented bit, read as '0'
u = Bit is unchanged	x = Bit is unknown	-n/n = Value at POR and BOR/Value at all other Resets
'1' = Bit is set	'0' = Bit is cleared	

bit 7-6 **Unimplemented:** Read as '0'

bit 5-0 **IOCCN<5:0>:** Interrupt-on-Change Negative Edge Enable bits

1 = Interrupt-on-Change enabled on the pin for a negative going edge. Associated Status bit and interrupt flag will be set upon detecting an edge.

0 = Interrupt-on-Change disabled for the associated pin.

## REGISTER 5-18: IOCCF: INTERRUPT-ON-CHANGE FLAG REGISTER

U-0	U-0	R/W/HS-0/0	R/W/HS-0/0	R/W/HS-0/0	R/W/HS-0/0	R/W/HS-0/0	R/W/HS-0/0
—	—	IOCCF5	IOCCF4	IOCCF3	IOCCF2	IOCCF1	IOCCF0
bit 7							bit 0

### Legend:

R = Readable bit	W = Writable bit	U = Unimplemented bit, read as '0'
u = Bit is unchanged	x = Bit is unknown	-n/n = Value at POR and BOR/Value at all other Resets
'1' = Bit is set	'0' = Bit is cleared	HS - Bit is set in hardware

bit 7-6 **Unimplemented:** Read as '0'

bit 5-0 **IOCCF<5:0>:** Interrupt-on-Change Flag bits

1 = An enabled change was detected on the associated pin.

Set when IOCCPx = 1 and a rising edge was detected on RBx, or when IOCCNx = 1 and a falling edge was detected on RCx.

0 = No change was detected, or the user cleared the detected change.



**TABLE 5-4: SUMMARY OF REGISTERS ASSOCIATED WITH PORTC**

Name	Bit 7	Bit 6	Bit 5	Bit 4	Bit 3	Bit 2	Bit 1	Bit 0	Register on Page
ADCON0	ADFM	—	CHS<3:0>			GO/DONE		ADON	118
ADCON1	—	ADCS<2:0>			—	—	—	ADPREF1	119
ANSELC	—	—	—	—	ANSC3	ANSC2	ANSC1	ANSC0	48
APFCON	—	—	—	T1GSEL	—	—	—	—	44
CM1CON0	C1ON	C1OUT	C1OE	C1POL	C1ZLF	C1SP	C1HYS	C1SYNC	139
CM2CON0	C2ON	C2OUT	C2OE	C2POL	C2ZLF	C2SP	C2HYS	C2SYNC	139
CM1CON1	C1INTP	C1INTN	C1PCH<2:0>			C1NCH<2:0>			140
CM2CON1	C2NTP	C2INTN	C2PCH<2:0>			C2NCH<2:0>			140
DAC1CON0	DACEN	DACFM	DACOE	—	DACPSS1	DACPSS0	—	—	130
IOCCF	—	—	IOCCF5	IOCCF4	IOCCF3	IOCCF2	IOCCF1	IOCCF0	49
IOCCN	—	—	IOCCN5	IOCCN4	IOCCN3	IOCCN2	IOCCN1	IOCCN0	49
IOCCP	—	—	IOCCP5	IOCCP4	IOCCP3	IOCCP2	IOCCP1	IOCCP0	49
LATC	—	—	LATC5	LATC4	—	LATC2	LATC1	LATC0	46
OPTION_REG	RAPU	INTEDG	T0CS	T0SE	PSA	PS<2:0>			18
PORTC	—	—	RC5	RC4	RC3	RC2	RC1	RC0	46
SLRCONC	—	—	SLRC5	SLRC4	—	—	—	—	54
TRISC	—	—	TRISC5	TRISC4	TRISC3 <sup>(1)</sup>	TRISC2	TRISC1	TRISC0	46

**Legend:** x = unknown, u = unchanged, — = unimplemented locations read as '0'. Shaded cells are not used by PORTA.

**Note 1:** TRISC3 always reads '1'.

# PIC16F753/HV753

---

NOTES:

## 6.0 TIMER0 MODULE

The Timer0 module is an 8-bit timer/counter with the following features:

- 8-bit timer/counter register (TMR0)
- 8-bit prescaler (shared with Watchdog Timer)
- Programmable internal or external clock source
- Programmable external clock edge selection
- Interrupt on overflow

Figure 6-1 is a block diagram of the Timer0 module.

## 6.1 Timer0 Operation

When used as a timer, the Timer0 module can be used as either an 8-bit timer or an 8-bit counter.

### 6.1.1 8-BIT TIMER MODE

When used as a timer, the Timer0 module will increment every instruction cycle (without prescaler). Timer mode is selected by clearing the T0CS bit of the OPTION register to '0'.

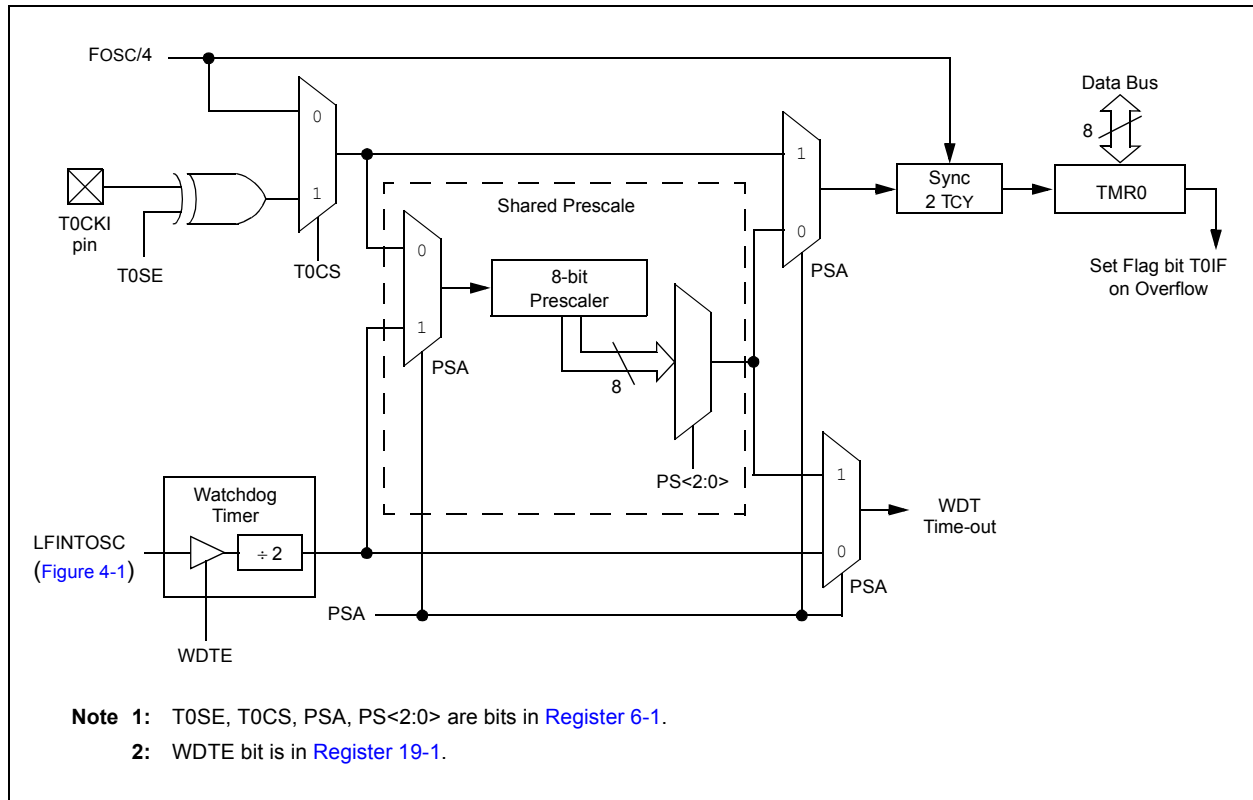
When TMR0 is written, the increment is inhibited for two instruction cycles immediately following the write.

**Note:** The value written to the TMR0 register can be adjusted, in order to account for the two instruction cycle delay when TMR0 is written.

### 6.1.2 8-BIT COUNTER MODE

When used as a counter, the Timer0 module will increment on every rising or falling edge of the T0CKI pin. The incrementing edge is determined by the T0SE bit of the OPTION\_REG register. Counter mode is selected by setting the T0CS bit of the OPTION register to '1'.

**FIGURE 6-1: TIMER0 WITH SHARED PRESCALE BLOCK DIAGRAM**



# PIC16F753/HV753

## 6.1.3 SOFTWARE PROGRAMMABLE PRESCALER

A single software programmable prescaler is available for use with either Timer0 or the Watchdog Timer (WDT), but not both simultaneously. The prescaler assignment is controlled by the PSA bit of the OPTION register. To assign the prescaler to Timer0, the PSA bit must be cleared to a '0'.

There are eight prescaler options for the Timer0 module ranging from 1:2 to 1:256. The prescale values are selectable via the PS<2:0> bits of the OPTION register. In order to have a 1:1 prescaler value for the Timer0 module, the prescaler must be assigned to the WDT module.

The prescaler is not readable or writable. When assigned to the Timer0 module, all instructions writing to the TMR0 register will clear the prescaler.

When the prescaler is assigned to WDT (PSA = 1), a CLRWDT instruction will clear the prescaler along with the WDT.

### 6.1.3.1 Switching Prescaler Between Timer0 and WDT Modules

As a result of having the prescaler assigned to either Timer0 or the WDT, it is possible to generate an unintended device Reset when switching prescaler values. When changing the prescaler assignment from Timer0 to the WDT module, the instruction sequence shown in [Example 6-1](#) must be executed.

#### EXAMPLE 6-1: CHANGING PRESCALER (TIMER0 → WDT)

```
BANKSEL TMR0      ;
CLRWDT            ;Clear WDT
CLRFB   TMR0      ;Clear TMR0 and
                  ;prescaler
BANKSEL OPTION_REG ;
BSF   OPTION_REG,PSA ;Select WDT
CLRWDT ;
                  ;
MOVLW b'11111000' ;Mask prescaler
ANDWF  OPTION_REG,W ;bits
IORLW  b'00000101' ;Set WDT prescaler
MOVWF  OPTION_REG  ;to 1:32
```

When changing the prescaler assignment from the WDT to the Timer0 module, the following instruction sequence must be executed (see [Example 6-2](#)).

#### EXAMPLE 6-2: CHANGING PRESCALER (WDT → TIMER0)

```
CLRWDT            ;Clear WDT and
                  ;prescaler
BANKSEL OPTION_REG ;
MOVLW  b'11110000' ;Mask TMR0 select and
ANDWF  OPTION_REG,W ;prescaler bits
IORLW  b'00000011' ;Set prescale to 1:16
MOVWF  OPTION_REG  ;
```

## 6.1.4 TIMER0 INTERRUPT

Timer0 will generate an interrupt when the TMR0 register overflows from FFh to 00h. The T0IF interrupt flag bit of the INTCON register is set every time the TMR0 register overflows, regardless of whether or not the Timer0 interrupt is enabled. The T0IF bit must be cleared in software. The Timer0 interrupt enable is the T0IE bit of the INTCON register.

**Note:** The Timer0 interrupt cannot wake the processor from Sleep since the timer is frozen during Sleep.

## 6.1.5 USING TIMER0 WITH AN EXTERNAL CLOCK

When Timer0 is in Counter mode, the synchronization of the T0CKI input and the Timer0 register is accomplished by sampling the prescaler output on the Q2 and Q4 cycles of the internal phase clocks. Therefore, the high and low periods of the external clock source must meet the timing requirements as shown in [Section 22.0 "Electrical Specifications"](#).

## 6.2 Register Definitions: Option and Timer0 Control

**REGISTER 6-1: OPTION\_REG: OPTION REGISTER**

R/W-1	R/W-1	R/W-1	R/W-1	R/W-1	R/W-1	R/W-1	R/W-1
$\overline{\text{RAPU}}$	INTEDG	T0CS	T0SE	PSA	PS<2:0>		
bit 7							bit 0

**Legend:**

R = Readable bit                      W = Writable bit                      U = Unimplemented bit, read as '0'  
 -n = Value at POR                      '1' = Bit is set                      '0' = Bit is cleared                      x = Bit is unknown

- bit 7             **$\overline{\text{RAPU}}$** : PORTA Pull-up Enable bit  
                  1 = PORTA pull-ups are disabled  
                  0 = PORTA pull-ups are enabled by individual PORT latch values in WPU register
- bit 6            **INTEDG**: Interrupt Edge Select bit  
                  1 = Interrupt on rising edge of INT pin  
                  0 = Interrupt on falling edge of INT pin
- bit 5            **T0CS**: TMR0 Clock Source Select bit  
                  1 = Transition on T0CKI pin  
                  0 = Internal instruction cycle clock (Fosc/4)
- bit 4            **T0SE**: TMR0 Source Edge Select bit  
                  1 = Increment on high-to-low transition on T0CKI pin  
                  0 = Increment on low-to-high transition on T0CKI pin
- bit 3            **PSA**: Prescaler Assignment bit  
                  1 = Prescaler is assigned to the WDT  
                  0 = Prescaler is assigned to the Timer0 module
- bit 2-0        **PS<2:0>**: Prescaler Rate Select bits

Bit Value	TMR0 Rate	WDT Rate
000	1:2	1:1
001	1:4	1:2
010	1:8	1:4
011	1:16	1:8
100	1:32	1:16
101	1:64	1:32
110	1:128	1:64
111	1:256	1:128

**TABLE 6-1: SUMMARY OF REGISTERS ASSOCIATED WITH TIMER0**

Name	Bit 7	Bit 6	Bit 5	Bit 4	Bit 3	Bit 2	Bit 1	Bit 0	Register on Page
TMR0	TMR0<7:0>								59*
INTCON	GIE	PEIE	T0IE	INTE	IOCFIE	T0IF	INTF	IOCF	19
OPTION_REG	$\overline{\text{RAPU}}$	INTEDG	T0CS	T0SE	PSA	PS<2:0>			61
TRISA	—	—	TRISA5	TRISA4	TRISA3 <sup>(1)</sup>	TRISA2	TRISA1	TRISA0	46

**Legend:** — = Unimplemented locations, read as '0', u = unchanged, x = unknown. Shaded cells are not used by the Timer0 module.

\* Page provides register information.

**Note 1:** TRISA3 always reads '1'.

# PIC16F753/HV753

---

NOTES:

## 7.0 TIMER1 MODULE WITH GATE CONTROL

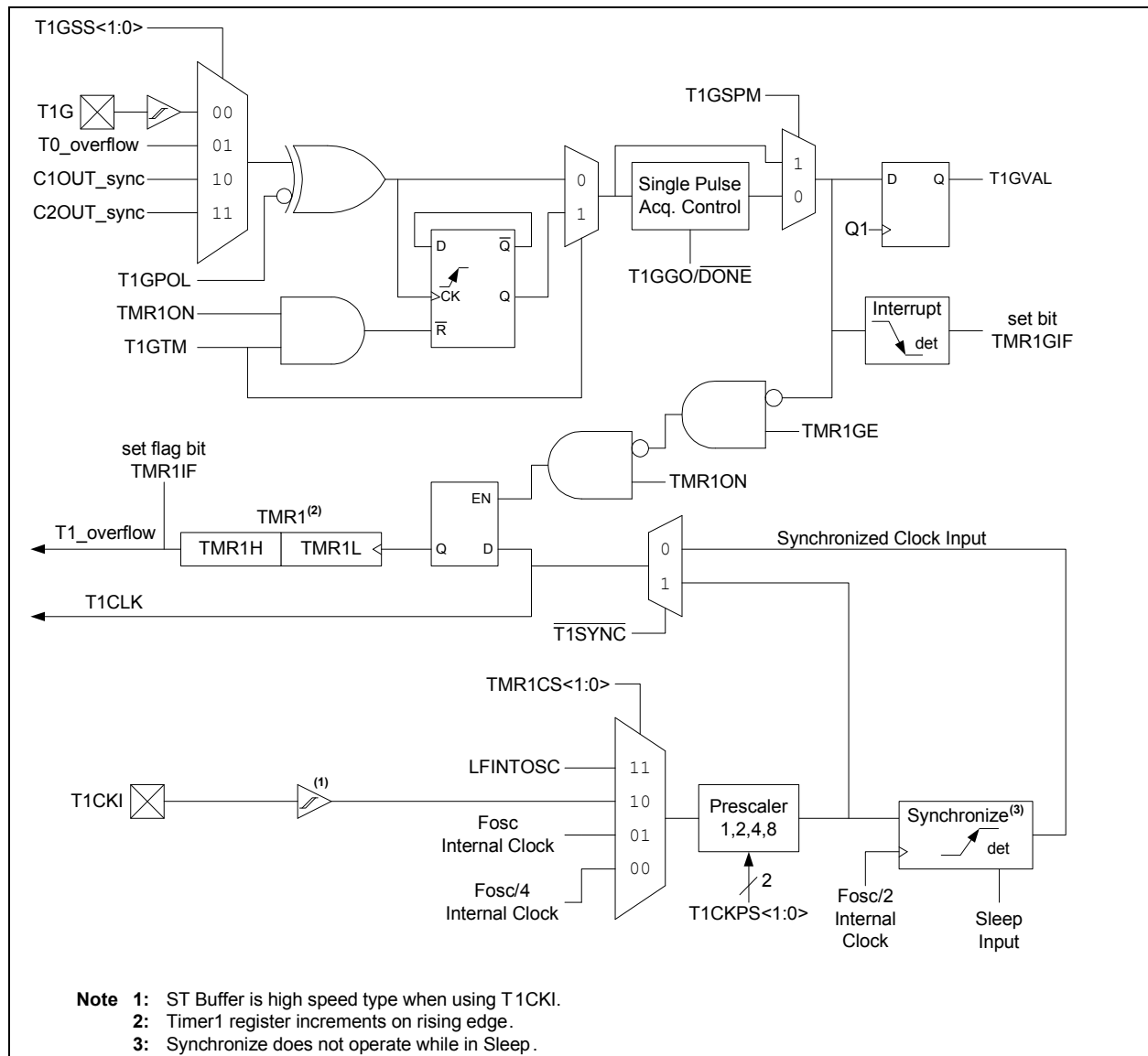
The Timer1 module is a 16-bit timer/counter with the following features:

- 16-bit timer/counter register pair (TMR1H:TMR1L)
- Selectable internal or external clock sources
- 2-bit prescaler
- Synchronous or asynchronous operation
- Multiple Timer1 gate (count enable) sources
- Interrupt on overflow
- Wake-up on overflow (external clock, Asynchronous mode only)
- Time base for the Capture/Compare function
- Special Event Trigger (with CCP)
- Selectable Gate Source Polarity

- Gate Toggle mode
- Gate Single-pulse mode
- Gate Value Status
- Gate Event Interrupt

Figure 7-1 is a block diagram of the Timer1 module.

**FIGURE 7-1: TIMER1 BLOCK DIAGRAM**



# PIC16F753/HV753

## 7.1 Timer1 Operation

The Timer1 module is a 16-bit incrementing counter which is accessed through the TMR1H:TMR1L register pair. Writes to TMR1H or TMR1L directly update the counter.

When used with an internal clock source, the module is a timer and increments on every instruction cycle. When used with an external clock source, the module can be used as either a timer or counter and increments on every selected edge of the external source.

Timer1 is enabled by configuring the TMR1ON and TMR1GE bits in the T1CON and T1GCON registers, respectively. [Table 7-1](#) displays the Timer1 enable selections.

**TABLE 7-1: TIMER1 ENABLE SELECTIONS**

TMR1ON	TMR1GE	Timer1 Operation
0	0	Off
0	1	Off
1	0	Always On
1	1	Count Enabled

## 7.2 Clock Source Selection

The TMR1CS<1:0> bits of the T1CON register are used to select the clock source for Timer1. [Table 7-2](#) displays the clock source selections.

**TABLE 7-2: CLOCK SOURCE SELECTIONS**

TMR1CS<1:0>	Clock Source
11	Temperature Sense Oscillator
10	External Clocking on T1CKI Pin
01	System Clock (Fosc)
00	Instruction Clock (Fosc/4)

### 7.2.1 INTERNAL CLOCK SOURCE

When the internal clock source is selected, the TMR1H:TMR1L register pair will increment on multiples of Fosc or Fosc/4 as determined by the Timer1 prescaler.

### 7.2.2 EXTERNAL CLOCK SOURCE

When the external clock source is selected, the Timer1 module may work as a timer or a counter. When enabled to count, Timer1 is incremented on the rising edge of the external clock input T1CKI.

**Note:** In Counter mode, a falling edge must be registered by the counter prior to the first incrementing rising edge (see [Figure 7-2](#)) after any one or more of the following conditions:

- Timer1 enabled after POR Reset
- Write to TMR1H or TMR1L
- Timer1 is disabled
- Timer1 is disabled (TMR1ON = 0) when T1CKI is high then Timer1 is enabled (TMR1ON=1) when T1CKI is low.

### 7.2.3 WDT OSCILLATOR

When the Watchdog is selected, Timer 1 will use the LFINTOSC that is used to operate the Watchdog Timer. This is the same oscillator as the LFINTOSC used as the system clock. Selecting this option will enable the oscillator even when the LFINTOSC or the Watchdog are not in use. This oscillator will continue to operate when in Sleep mode.



## 7.3 Timer1 Prescaler

Timer1 has four prescaler options allowing one, two, four or eight divisions of the clock input. The T1CKPS bits of the T1CON register control the prescale counter. The prescale counter is not directly readable or writable; however, the prescaler counter is cleared upon a write to TMR1H or TMR1L.

## 7.4 Timer1 Operation in Asynchronous Counter Mode

If control bit  $\overline{T1SYNC}$  of the T1CON register is set, the external clock input is not synchronized. The timer increments asynchronously to the internal phase clocks. If external clock source is selected then the timer will continue to run during Sleep and can generate an interrupt on overflow, which will wake-up the processor. However, special precautions in software are needed to read/write the timer (see [Section 7.4.1 “Reading and Writing Timer1 in Asynchronous Counter Mode”](#)).

**Note:** When switching from synchronous to asynchronous operation, it is possible to skip an increment. When switching from asynchronous to synchronous operation, it is possible to produce an additional increment.

### 7.4.1 READING AND WRITING TIMER1 IN ASYNCHRONOUS COUNTER MODE

Reading TMR1H or TMR1L while the timer is running from an external asynchronous clock will ensure a valid read (taken care of in hardware). However, the user should keep in mind that reading the 16-bit timer in two 8-bit values itself, poses certain problems, since the timer may overflow between the reads.

For writes, it is recommended that the user simply stop the timer and write the desired values. A write contention may occur by writing to the timer registers, while the register is incrementing. This may produce an unpredictable value in the TMR1H:TMR1L register pair.

## 7.5 Timer1 Gate

Timer1 can be configured to count freely or the count can be enabled and disabled using Timer1 gate circuitry. This is also referred to as Timer1 gate count enable.

Timer1 gate can also be driven by multiple selectable sources.

### 7.5.1 TIMER1 GATE COUNT ENABLE

The Timer1 gate is enabled by setting the TMR1GE bit of the T1GCON register. The polarity of the Timer1 gate is configured using the T1GPOL bit of the T1GCON register.

When Timer1 Gate (T1G) input is active, Timer1 will increment on the rising edge of the Timer1 clock source. When Timer1 gate input is inactive, no incrementing will occur and Timer1 will hold the current count. See [Figure 7-3](#) for timing details.

**TABLE 7-3: TIMER1 GATE ENABLE SELECTIONS**

T1CLK	T1GPOL	T1G	Timer1 Operation
↑	0	0	Counts
↑	0	1	Holds Count
↑	1	0	Holds Count
↑	1	1	Counts

### 7.5.2 TIMER1 GATE SOURCE SELECTION

The Timer1 gate source can be selected from one of four different sources. Source selection is controlled by the T1GSS bits of the T1GCON register. The polarity for each available source is also selectable. Polarity selection is controlled by the T1GPOL bit of the T1GCON register.

**TABLE 7-4: TIMER1 GATE SOURCES**

T1GSS	Timer1 Gate Source
11	SYNCC2OUT
10	SYNCC1OUT
01	Overflow of Timer0 (TMR0 increments from FFh to 00h)
00	Timer1 Gate Pin

# PIC16F753/HV753

---

## 7.5.2.1 T1G Pin Gate Operation

The T1G pin is one source for Timer1 gate control. It can be used to supply an external source to the Timer1 gate circuitry.

## 7.5.2.2 Timer0 Overflow Gate Operation

When Timer0 increments from FFh to 00h, a low-to-high pulse will automatically be generated and internally supplied to the Timer1 gate circuitry.

## 7.5.2.3 C1OUT/C2OUT Gate Operation

The outputs from the Comparator C1 and C2 modules can be used as gate sources for the Timer1 module.

## 7.5.3 TIMER1 GATE TOGGLE MODE

When Timer1 Gate Toggle mode is enabled, it is possible to measure the full-cycle length of a Timer1 gate signal, as opposed to the duration of a single-level pulse.

The Timer1 gate source is routed through a flip-flop that changes state on every incrementing edge of the signal. See [Figure 7-4](#) for timing details.

Timer1 Gate Toggle mode is enabled by setting the T1GTM bit of the T1GCON register. When the T1GTM bit is cleared, the flip-flop is cleared and held clear. This is necessary in order to control which edge is measured.

<b>Note:</b> Enabling Toggle mode at the same time as changing the gate polarity may result in indeterminate operation.
---

## 7.5.4 TIMER1 GATE SINGLE-PULSE MODE

When Timer1 Gate Single-Pulse mode is enabled, it is possible to capture a single-pulse gate event. Timer1 Gate Single-Pulse mode is first enabled by setting the T1GSPM bit in the T1GCON register. Next, the T1GGO/ $\overline{\text{DONE}}$  bit in the T1GCON register must be set. The Timer1 will be fully enabled on the next incrementing edge. On the next trailing edge of the pulse, the T1GGO/ $\overline{\text{DONE}}$  bit will automatically be cleared. No other gate events will be allowed to increment Timer1 until the T1GGO/ $\overline{\text{DONE}}$  bit is once again set in software.

Clearing the T1GSPM bit of the T1GCON register will also clear the T1GGO/ $\overline{\text{DONE}}$  bit. See [Figure 7-5](#) for timing details.

Enabling the Toggle mode and the Single-Pulse mode simultaneously will permit both sections to work together. This allows the cycle times on the Timer1 gate source to be measured. See [Figure 7-6](#) for timing details.

## 7.5.5 TIMER1 GATE VALUE STATUS

When Timer1 gate value status is utilized, it is possible to read the most current level of the gate control value. The value is stored in the T1GVAL bit in the T1GCON register. The T1GVAL bit is valid even when the Timer1 gate is not enabled (TMR1GE bit is cleared).

## 7.5.6 TIMER1 GATE EVENT INTERRUPT

When Timer1 gate event interrupt is enabled, it is possible to generate an interrupt upon the completion of a gate event. When the falling edge of T1GVAL occurs, the TMR1GIF flag bit in the PIR1 register will be set. If the TMR1GIE bit in the PIE1 register is set, then an interrupt will be recognized.

The TMR1GIF flag bit operates even when the Timer1 gate is not enabled (TMR1GE bit is cleared).

## 7.6 Timer1 Interrupt

The Timer1 register pair (TMR1H:TMR1L) increments to FFFFh and rolls over to 0000h. When Timer1 rolls over, the Timer1 interrupt flag bit of the PIR1 register is set. To enable the interrupt on rollover, you must set these bits:

- TMR1ON bit of the T1CON register
- TMR1IE bit of the PIE1 register
- PEIE bit of the INTCON register
- GIE bit of the INTCON register

The interrupt is cleared by clearing the TMR1IF bit in the Interrupt Service Routine.

**Note:** The TMR1H:TMR1L register pair and the TMR1IF bit should be cleared before enabling interrupts.

## 7.7 Timer1 Operation During Sleep

Timer1 can only operate during Sleep when set up in Asynchronous Counter mode or with the internal watchdog clock source. In this mode, the clock source can be used to increment the counter. To set up the timer to wake the device:

- TMR1ON bit of the T1CON register must be set
- TMR1IE bit of the PIE1 register must be set
- PEIE bit of the INTCON register must be set
- T1SYNC bit of the T1CON register must be set
- TMR1CS bits of the T1CON register must be configured
- TMR1GE bit of the T1GCON register must be configured

The device will wake-up on an overflow and execute the next instructions. If the GIE bit of the INTCON register is set, the device will call the Interrupt Service Routine (0004h).

## 7.8 CCP Capture/Compare Time Base

The CCP module uses the TMR1H:TMR1L register pair as the time base when operating in Capture or Compare mode.

In Capture mode, the value in the TMR1H:TMR1L register pair is copied into the CCPR1H:CCPR1L register pair on a configured event.

In Compare mode, an event is triggered when the value CCPR1H:CCPR1L register pair matches the value in the TMR1H:TMR1L register pair. This event can be a Special Event Trigger.

For more information, see [Section 10.0 “Capture/Compare/PWM Modules”](#).

## 7.9 CCP Special Event Trigger

When the CCP is configured to trigger a special event, the trigger will clear the TMR1H:TMR1L register pair. This special event does not cause a Timer1 interrupt. The CCP module may still be configured to generate a CCP interrupt.

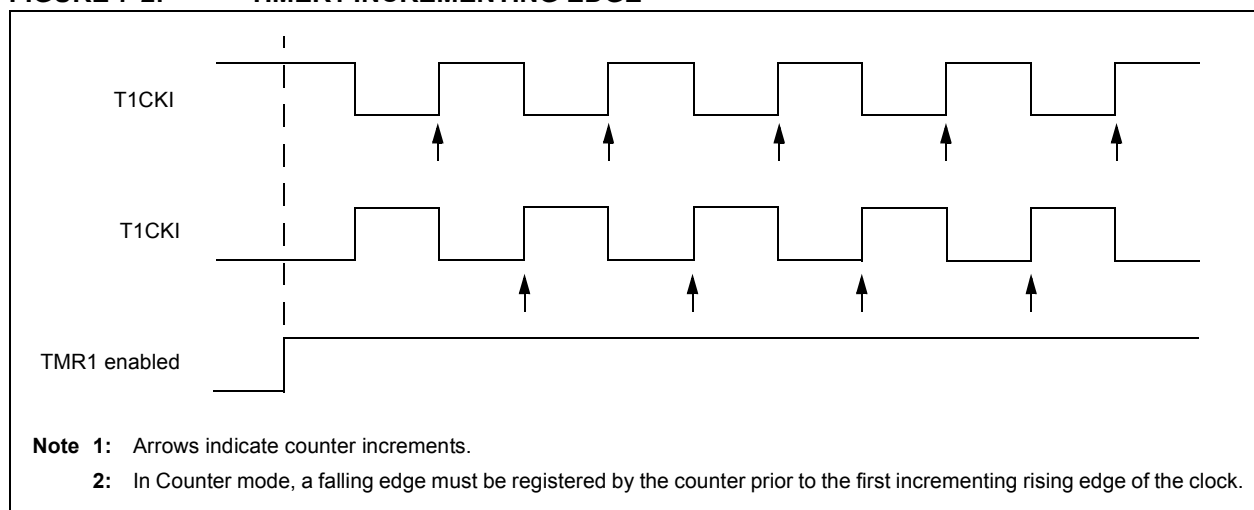
In this mode of operation, the CCPR1H:CCPR1L register pair becomes the period register for Timer1.

Timer1 should be synchronized to the FOSC/4 to utilize the Special Event Trigger. Asynchronous operation of Timer1 can cause a Special Event Trigger to be missed.

In the event that a write to TMR1H or TMR1L coincides with a Special Event Trigger from the CCP, the write will take precedence.

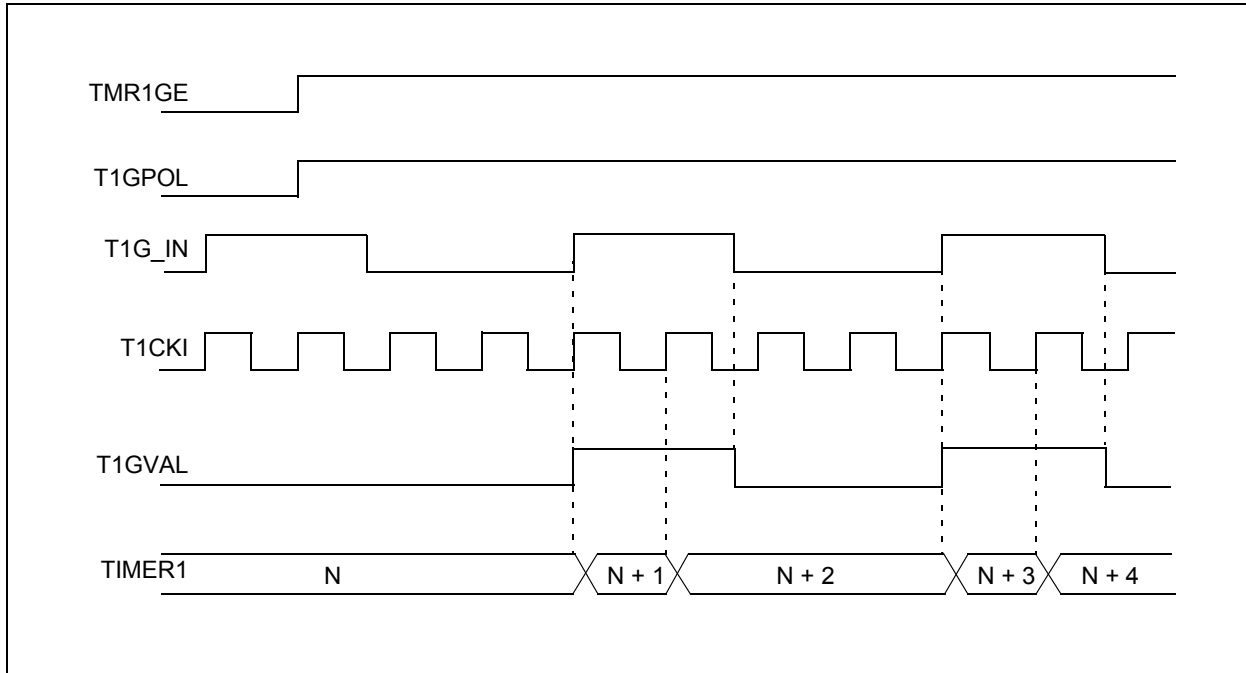
For more information, see [Section 12.2.5 “Special Event Trigger”](#).

**FIGURE 7-2: TIMER1 INCREMENTING EDGE**

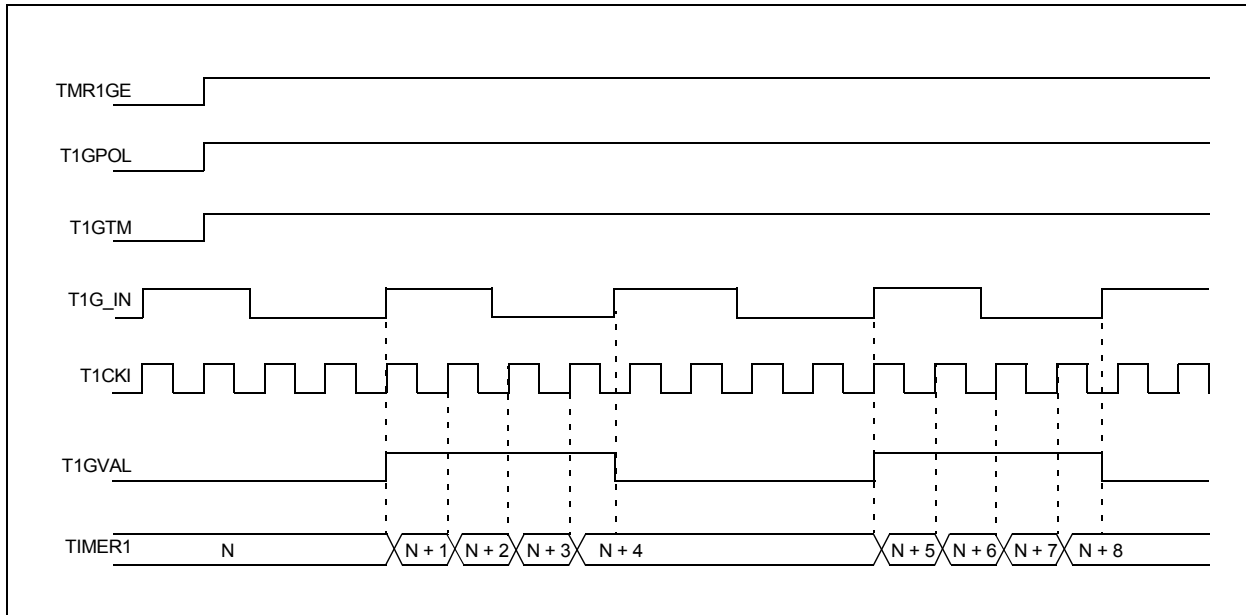


# PIC16F753/HV753

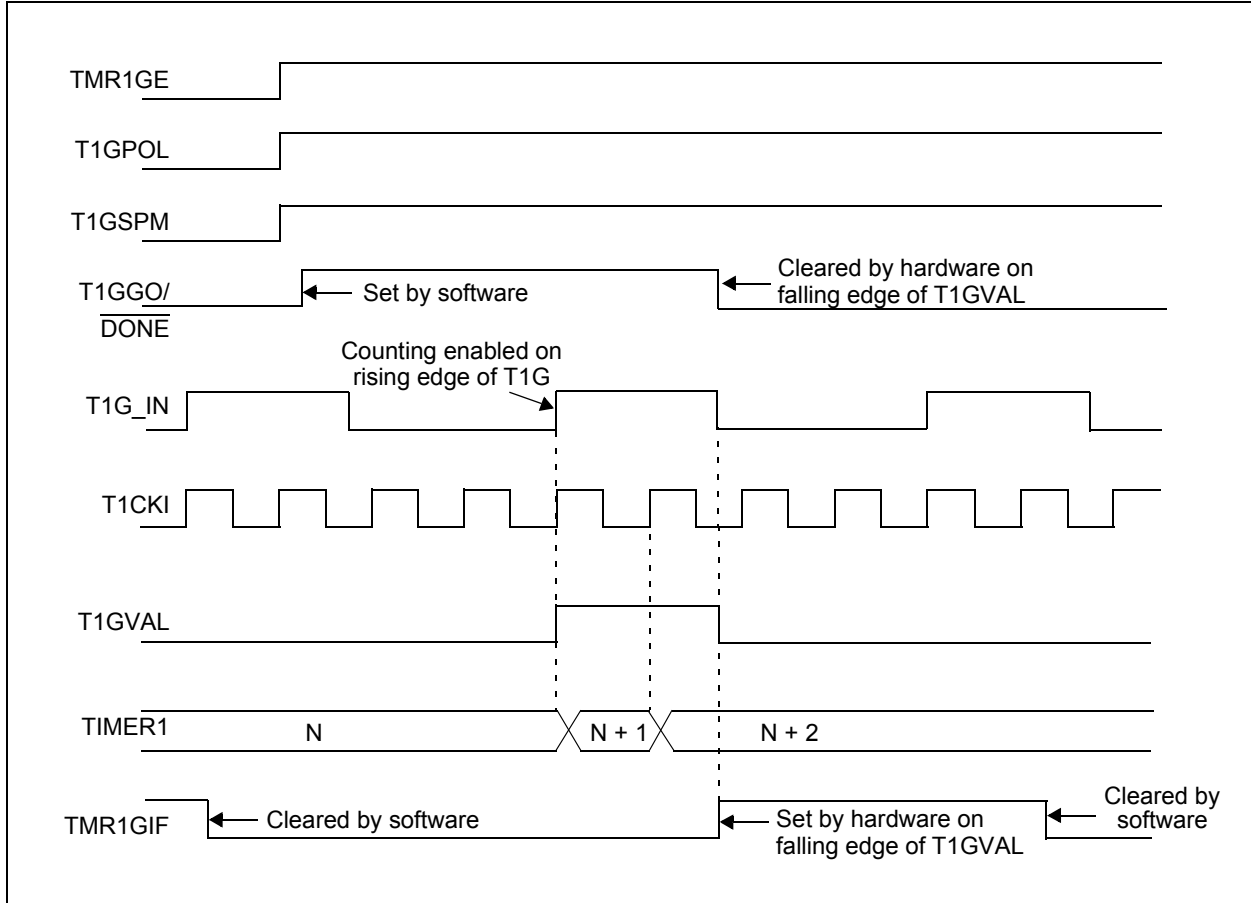
**FIGURE 7-3: TIMER1 GATE COUNT ENABLE MODE**



**FIGURE 7-4: TIMER1 GATE TOGGLE MODE**

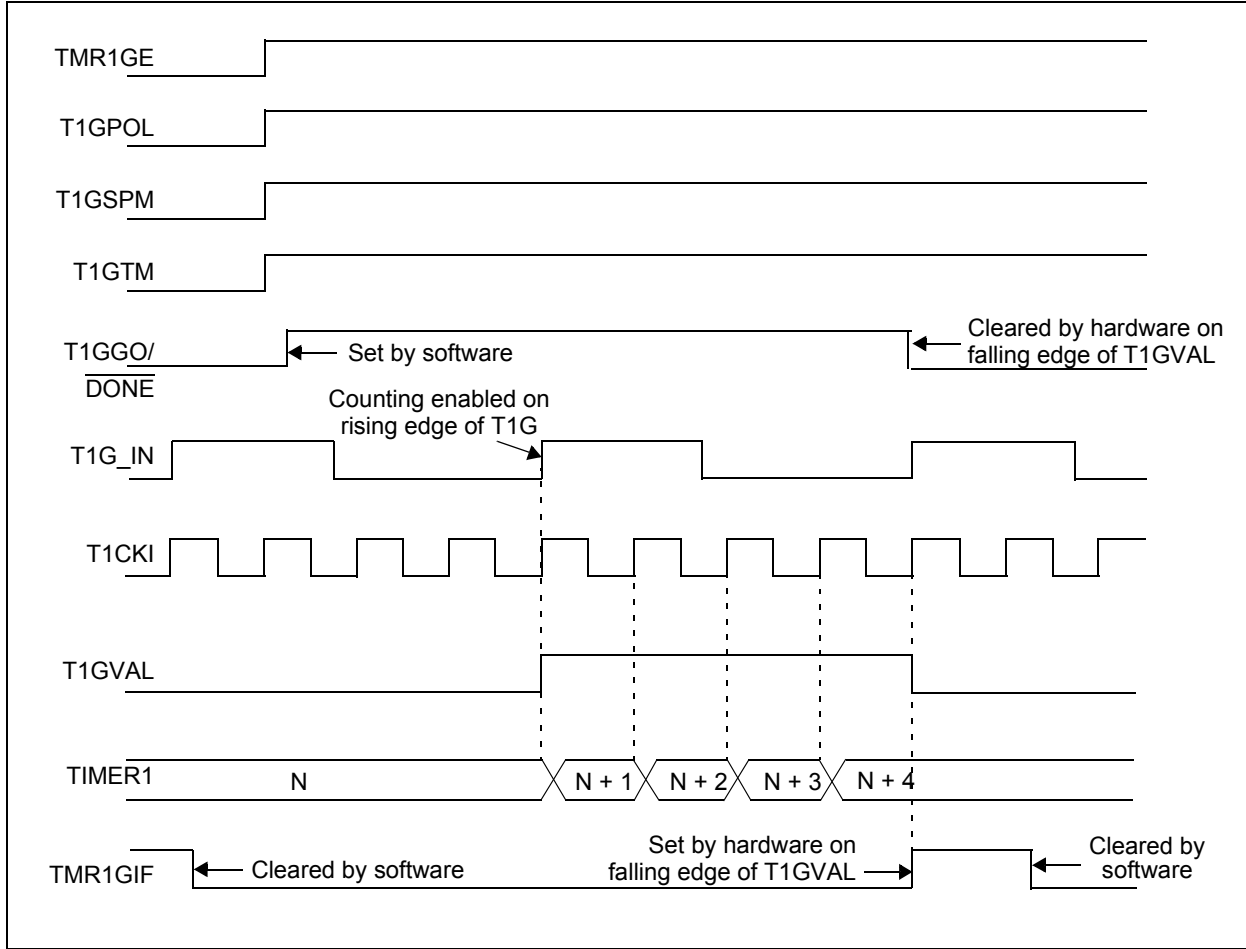


**FIGURE 7-5: TIMER1 GATE SINGLE-PULSE MODE**



# PIC16F753/HV753

FIGURE 7-6: TIMER1 GATE SINGLE-PULSE AND TOGGLE COMBINED MODE



## 7.10 Register Definitions: Timer1 Control

### REGISTER 7-1: T1CON: TIMER1 CONTROL REGISTER

R/W-0	R/W-0	R/W-0	R/W-0	R/W-0	R/W-0	U-0	R/W-0
TMR1CS<1:0>		T1CKPS<1:0>		T1OSCEN	T1SYNC	—	TMR1ON
bit 7							bit 0

#### Legend:

R = Readable bit	W = Writable bit	U = Unimplemented bit, read as '0'
-n = Value at POR	'1' = Bit is set	'0' = Bit is cleared
		x = Bit is unknown

- bit 7-6      **TMR1CS<1:0>**: Timer1 Clock Source Select bits  
 11 = Watchdog timer oscillator  
 10 = External clock from T1CKI pin (on the rising edge)  
 01 = Timer1 clock source is system clock (Fosc)  
 00 = Timer1 clock source is instruction clock (Fosc/4)
- bit 5-4      **T1CKPS<1:0>**: Timer1 Input Clock Prescale Select bits  
 11 = 1:8 Prescale value  
 10 = 1:4 Prescale value  
 01 = 1:2 Prescale value  
 00 = 1:1 Prescale value
- bit 3        **T1OSCEN**: This bit is ignored.
- bit 2        **T1SYNC**: Timer1 External Clock Input Synchronization Control bit  
TMR1CS<1:0> = 1X  
 1 = Do not synchronize external clock input  
 0 = Synchronize external clock input with system clock (Fosc)
- TMR1CS<1:0> = 0X  
 This bit is ignored. Timer1 uses the internal clock when TMR1CS<1:0> = 1X.
- bit 1        **Unimplemented**: Read as '0'
- bit 0        **TMR1ON**: Timer1 On bit  
 1 = Enables Timer1  
 0 = Stops Timer1  
 Clears Timer1 gate flip-flop

# PIC16F753/HV753

## REGISTER 7-2: T1GCON: TIMER1 GATE CONTROL REGISTER

R/W-0	R/W-0	R/W-0	R/W-0	R/W-0	R-x	R/W-0	R/W-0
TMR1GE	T1GPOL	T1GTM	T1GSPM	T1GGO/DONE	T1GVAL	T1GSS<1:0>	
bit 7						bit 0	

### Legend:

R = Readable bit

W = Writable bit

U = Unimplemented bit, read as '0'

-n = Value at POR

'1' = Bit is set

'0' = Bit is cleared

x = Bit is unknown

bit 7 **TMR1GE:** Timer1 Gate Enable bit

If TMR1ON = 0:

This bit is ignored

If TMR1ON = 1:

1 = Timer1 counting is controlled by the Timer1 gate function

0 = Timer1 counts regardless of Timer1 gate function

bit 6 **T1GPOL:** Timer1 Gate Polarity bit

1 = Timer1 gate is active-high (Timer1 counts when gate is high)

0 = Timer1 gate is active-low (Timer1 counts when gate is low)

bit 5 **T1GTM:** Timer1 Gate Toggle mode bit

1 = Timer1 Gate Toggle mode is enabled.

0 = Timer1 Gate Toggle mode is disabled and toggle flip-flop is cleared

Timer1 gate flip-flop toggles on every rising edge.

bit 4 **T1GSPM:** Timer1 Gate Single-Pulse mode bit

1 = Timer1 Gate Single-Pulse mode is enabled and is controlling Timer1 gate

0 = Timer1 Gate Single-Pulse mode is disabled

bit 3 **T1GGO/DONE:** Timer1 Gate Single-Pulse Acquisition Status bit

1 = Timer1 gate single-pulse acquisition is ready, waiting for an edge

0 = Timer1 gate single-pulse acquisition has completed or has not been started

This bit is automatically cleared when T1GSPM is cleared.

bit 2 **T1GVAL:** Timer1 Gate Current State bit

Indicates the current state of the Timer1 gate that could be provided to TMR1H:TMR1L.

Unaffected by Timer1 Gate Enable (TMR1GE).

bit 1-0 **T1GSS<1:0>:** Timer1 Gate Source Select bits

11 = SYNCC2OUT

10 = SYNCC1OUT

01 = Timer0 overflow output

00 = Timer1 gate pin



**TABLE 7-5: SUMMARY OF REGISTERS ASSOCIATED WITH TIMER1**

Name	Bit 7	Bit 6	Bit 5	Bit 4	Bit 3	Bit 2	Bit 1	Bit 0	Register on Page
ANSELA	—	—	—	ANSA4	—	ANSA2	ANSA1	ANSA0	48
APFCON	—	—	—	T1GSEL	—	—	—	—	44
CCP1CON	—	—	DC1B<1:0>		CCP1M<3:0>				87
INTCON	GIE	PEIE	T0IE	INTE	IOCIE	T0IF	INTF	IOCIF	19
PIE1	TMR1GIE	ADIE	—	—	HLTMR2IE	HLTMR1IE	TMR2IE	TMR1IE	20
PIR1	TMR1GIF	ADIF	—	—	HLTMR2IF	HLTMR1IF	TMR2IF	TMR1IF	22
PORTA	—	—	RA5	RA4	RA3	RA2	RA1	RA0	46
TMR1H	TMR1H<7:0>								63*
TMR1L	TMR1L<7:0>								63*
TRISA	—	—	TRISA5	TRISA4	TRISA3	TRISA2	TRISA1	TRISA0	46
T1CON	TMR1CS<1:0>		T1CKPS<1:0>		T1OSCEN	T1SYNC	—	TMR1ON	71
T1GCON	TMR1GE	T1GPOL	T1GTM	T1GSPM	T1GGO/ DONE	T1GVAL	T1GSS<1:0>		72

**Legend:** x = unknown, u = unchanged, - = unimplemented, read as '0'. Shaded cells are not used by the Timer1 module.

\* Page provides register information.

# PIC16F753/HV753

---

NOTES:

## 8.0 TIMER2 MODULE

The Timer2 module is an 8-bit timer with the following features:

- 8-bit timer register (TMR2)
- 8-bit period register (PR2)
- Interrupt on TMR2 match with PR2
- Software programmable prescaler (1:1, 1:4, 1:16, 1:64)
- Software programmable postscaler (1:1 to 1:16)

See Figure 8-1 for a block diagram of Timer2.

### 8.1 Timer2 Operation

The clock input to the Timer2 module is the system instruction clock ( $F_{osc}/4$ ). The clock is fed into the Timer2 prescaler, which has prescale options of 1:1, 1:4 or 1:16. The output of the prescaler is then used to increment the TMR2 register.

The values of TMR2 and PR2 are constantly compared to determine when they match. TMR2 will increment from 00h until it matches the value in PR2. When a match occurs, two things happen:

- TMR2 is reset to 00h on the next increment cycle.
- The Timer2 postscaler is incremented

The match output of the Timer2/PR2 comparator is then fed into the Timer2 postscaler. The postscaler has postscale options of 1:1 to 1:16 inclusive. The output of the Timer2 postscaler is used to set the TMR2IF interrupt flag bit in the PIR1 register.

The TMR2 and PR2 registers are both fully readable and writable. On any Reset, the TMR2 register is set to 00h and the PR2 register is set to FFh.

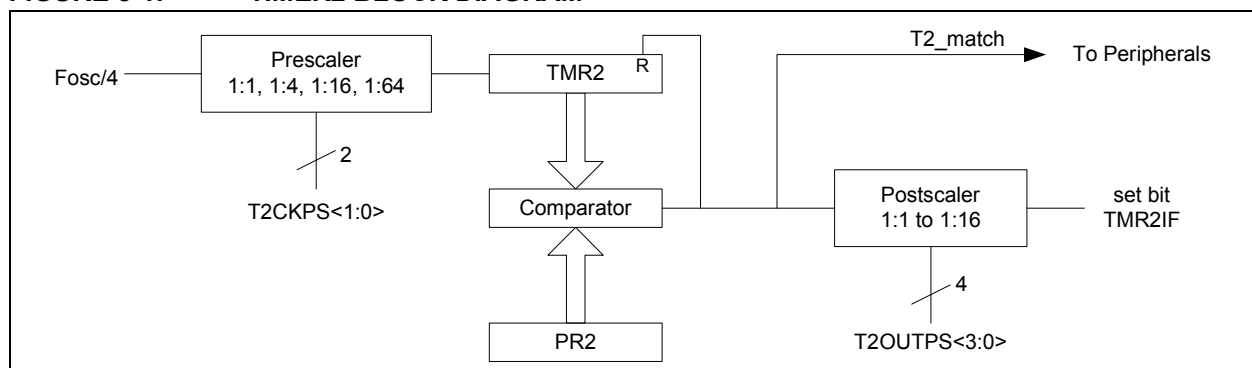
Timer2 is turned on by setting the TMR2ON bit in the T2CON register to a '1'. Timer2 is turned off by clearing the TMR2ON bit to a '0'.

The Timer2 prescaler is controlled by the T2CKPS bits in the T2CON register. The Timer2 postscaler is controlled by the T2OUTPS bits in the T2CON register. The prescaler and postscaler counters are cleared when:

- A write to TMR2 occurs.
- A write to T2CON occurs.
- Any device Reset occurs (Power-on Reset,  $\overline{MCLR}$  Reset, Watchdog Timer Reset, or Brown-out Reset).

**Note:** TMR2 is not cleared when T2CON is written.

**FIGURE 8-1: TIMER2 BLOCK DIAGRAM**



# PIC16F753/HV753

## 8.2 Register Definitions: Timer2 Control

**REGISTER 8-1: T2CON: TIMER2 CONTROL REGISTER**

U-0	R/W-0	R/W-0	R/W-0	R/W-0	R/W-0	R/W-0	R/W-0
—	T2OUTPS<3:0>				TMR2ON	T2CKPS<1:0>	
bit 7							bit 0

**Legend:**

R = Readable bit                      W = Writable bit                      U = Unimplemented bit, read as '0'  
 -n = Value at POR                      '1' = Bit is set                      '0' = Bit is cleared                      x = Bit is unknown

- bit 7                      **Unimplemented:** Read as '0'
- bit 6-3                **T2OUTPS<3:0>:** Timer2 Output Postscaler Select bits
  - 0000 = 1:1 Postscaler
  - 0001 = 1:2 Postscaler
  - 0010 = 1:3 Postscaler
  - 0011 = 1:4 Postscaler
  - 0100 = 1:5 Postscaler
  - 0101 = 1:6 Postscaler
  - 0110 = 1:7 Postscaler
  - 0111 = 1:8 Postscaler
  - 1000 = 1:9 Postscaler
  - 1001 = 1:10 Postscaler
  - 1010 = 1:11 Postscaler
  - 1011 = 1:12 Postscaler
  - 1100 = 1:13 Postscaler
  - 1101 = 1:14 Postscaler
  - 1110 = 1:15 Postscaler
  - 1111 = 1:16 Postscaler
- bit 2                      **TMR2ON:** Timer2 On bit
  - 1 = Timer2 is on
  - 0 = Timer2 is off
- bit 1-0                **T2CKPS<1:0>:** Timer2 Clock Prescale Select bits
  - 00 = Prescaler is 1
  - 01 = Prescaler is 4
  - 10 = Prescaler is 16
  - 11 = Prescaler is 64

**TABLE 8-1: SUMMARY OF REGISTERS ASSOCIATED WITH TIMER2**

Name	Bit 7	Bit 6	Bit 5	Bit 4	Bit 3	Bit 2	Bit 1	Bit 0	Register on Page
INTCON	GIE	PEIE	T0IE	INTE	IOCIE	T0IF	INTF	IOCIF	19
PIE1	TMR1GIE	ADIE	—	—	HLTMR2IE	HLTMR1IE	TMR2IE	TMR1IE	20
PIR1	TMR1GIF	ADIF	—	—	HLTMR2IF	HLTMR1IF	TMR2IF	TMR1IF	22
PR2	PR2<7:0>								75*
TMR2	TMR2<7:0>								75*
T2CON	—	T2OUTPS<3:0>				TMR2ON	T2CKPS<1:0>		76

**Legend:** x = unknown, u = unchanged, - = unimplemented read as '0'. Shaded cells are not used for Timer2 module.  
 \* Page provides register information.

## 9.0 HARDWARE LIMIT TIMER (HLT) MODULE

The Hardware Limit Timer (HLT) module is a version of the Timer2-type modules. In addition to all the Timer2-type features, the HLT can be reset on rising and falling events from selected peripheral outputs.

The HLT primary purpose is to act as a timed hardware limit to be used in conjunction with asynchronous analog feedback applications. The external Reset source synchronizes the HLTMRx to an analog application.

In normal operation, the external Reset source from the analog application should occur before the HLTMRx matches the HLTPrx. This resets HLTMRx for the next period and prevents the HLTMRx Output from going active.

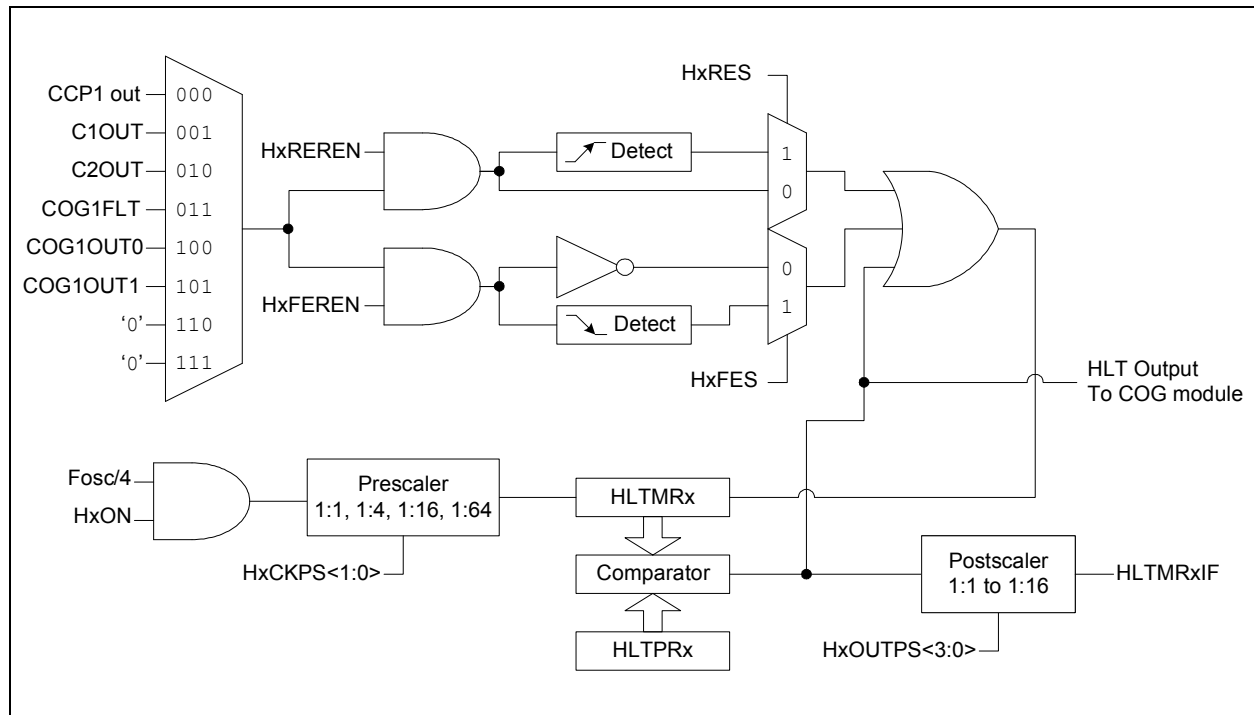
When the external Reset source fails to generate a signal within the expected time, (allowing the HLTMRx to match the HLTPrx), then the HLTMRx Output becomes active.

The HLT module incorporates the following features:

- 8-bit Read-Write Timer Register (HLTMRx)
- 8-bit Read-Write Period register (HLTPrx)
- Software programmable prescaler:
  - 1:1
  - 1:4
  - 1:16
  - 1:64
- Software programmable postscaler
  - 1:1 to 1:16, inclusive
- Interrupt on HLTMRx match with HLTPrx
- Eight selectable timer Reset inputs (two reserved)
- Reset on rising and falling event

Refer to [Figure 9-1](#) for a block diagram of the HLT.

**FIGURE 9-1: HLTMRx BLOCK DIAGRAM**



# PIC16F753/HV753

## 9.1 HLT Operation

The clock input to the HLT module is the system instruction clock (Fosc/4). HLTMRx increments on each rising clock edge.

A 4-bit counter/prescaler on the clock input provides the following prescale options:

- Direct input
- Divide-by-4
- Divide-by-16
- Divide-by-64

The prescale options are selected by the prescaler control bits, HxCKPS<1:0> of the HLTxCON0 register.

The value of HLTMRx is compared to that of the Period register, HLTPRx, on each clock cycle. When the two values match, then the comparator generates a match signal as the HLTimerx output. This signal also resets the value of HLTMRx to 00h on the next clock rising edge and drives the output counter/postscaler (see [Section 9.2 “HLT Interrupt”](#)).

The HLTMRx and HLTPRx registers are both directly readable and writable. The HLTMRx register is cleared on any device Reset, whereas the HLTPRx register initializes to FFh. Both the prescaler and postscaler counters are cleared on any of the following events:

- A write to the HLTMRx register
- A write to the HLTxCON0 register
- Power-on Reset (POR)
- Brown-out Reset (BOR)
- MCLR Reset
- Watchdog Timer (WDT) Reset
- Stack Overflow Reset
- Stack Underflow Reset
- RESET Instruction

**Note:** HLTMRx is not cleared when HLTxCON0 is written.

## 9.2 HLT Interrupt

The HLT can also generate an optional device interrupt. The HLTMRx output signal (HLTMRx-to-HLTPRx match) provides the input for the 4-bit counter/postscaler. The overflow output of the postscaler sets the HLTMRxIF bit of the PIR1 register. The interrupt is enabled by setting the HLTMRx Match Interrupt Enable bit, HLTMRxIE of the PIE1 register.

A range of 16 postscale options (from 1:1 through 1:16 inclusive) can be selected with the postscaler control bits, HxOUTPS<3:0>, of the HLTxCON0 register.

## 9.3 Peripheral Resets

Resets driven from the selected peripheral output prevents the HLTMRx from matching the HLTPRx register and generating an output. In this manner, the HLT can be used as a hardware time limit to other peripherals.

In this device, the primary purpose of the HLT is to limit the COG PWM duty cycle. Normally, the COG operation uses analog feedback to determine the PWM duty cycle. The same feedback signal is used as an HLT Reset input. The HLTPRx register is set to occur at the maximum allowed duty cycle. If the analog feedback to the COG exceeds the maximum time, then an HLTMRx-to-HLTPRx match will occur and generate the output needed to limit the COG drive output.

The HLTMRx can be reset by one of several selectable peripheral sources. Reset inputs include:

- CCP1 output
- Comparator 1 output
- Comparator 2 output
- COGxFLT pin
- COG1OUT0
- COG1OUT1

The external Reset input is selected with the HxERS<2:0> bits of the HLTxCON1 register. High and low Reset enables are selected with the HxREREN and HxFEREN bits, respectively. Setting the HxRES and HxFES bits makes the respective rising and falling Reset events edge sensitive. Reset inputs that are not edge sensitive are level sensitive.

HLTMRx Resets are synchronous with the HLT clock. In other words, HLTMRx is cleared on the rising edge of the HLT clock after the enabled Reset event occurs.

If an enabled external Reset occurs at the same time a write occurs to the TMR4A register, the write to the timer takes precedence and pending Resets are cleared.

## 9.4 HLTimerx Output

The unscaled output of HLTMRx is available only to the COG module, where it is used as a selectable limit to the maximum COG period.

## 9.5 HLT Operation During Sleep

The HLT cannot be operated while the processor is in Sleep mode. The contents of the HLTMRx register will remain unchanged while the processor is in Sleep mode.

## 9.6 Register Definitions: HLT Control Registers

### REGISTER 9-1: HLTxCON0: HLTx CONTROL REGISTER 0

U-0	R/W-0/0	R/W-0/0	R/W-0/0	R/W-0/0	R/W-0/0	R/W-0/0	R/W-0/0
—	HxOUTPS<3:0>			HxON	HxCKPS<1:0>		
bit 7							bit 0

#### Legend:

R = Readable bit	W = Writable bit	U = Unimplemented bit, read as '0'
u = Bit is unchanged	x = Bit is unknown	-n/n = Value at POR and BOR/Value at all other Resets
'1' = Bit is set	'0' = Bit is cleared	

bit 7      **Unimplemented:** Read as '0'

bit 6-3      **HxOUTPS<3:0>:** Hardware Limit Timerx Output Postscaler Select bits

0000 = 1:1 Postscaler  
 0001 = 1:2 Postscaler  
 0010 = 1:3 Postscaler  
 0011 = 1:4 Postscaler  
 0100 = 1:5 Postscaler  
 0101 = 1:6 Postscaler  
 0110 = 1:7 Postscaler  
 0111 = 1:8 Postscaler  
 1000 = 1:9 Postscaler  
 1001 = 1:10 Postscaler  
 1010 = 1:11 Postscaler  
 1011 = 1:12 Postscaler  
 1100 = 1:13 Postscaler  
 1101 = 1:14 Postscaler  
 1110 = 1:15 Postscaler  
 1111 = 1:16 Postscaler

bit 2      **HxON:** Hardware Limit Timerx On bit

1 = Timer is on  
 0 = Timer is off

bit 1-0      **HxCKPS<1:0>:** Hardware Limit Timer x Clock Prescale Select bits

00 = Prescaler is 1  
 01 = Prescaler is 4  
 10 = Prescaler is 16  
 11 = Prescaler is 64

# PIC16F753/HV753

**REGISTER 9-2: HLTxCON1: HLTx CONTROL REGISTER 1**

R/W-0/0	R/W-0/0	U-0	R/W-0/0	R/W-0/0	R/W-0/0	R/W-0/0	R/W-0/0
HxFES	HxRES	—	HxERS<2:0>			HxFEREN	HxREREN
bit 7							bit 0

**Legend:**

R = Readable bit                      W = Writable bit                      U = Unimplemented bit, read as '0'  
u = Bit is unchanged                  x = Bit is unknown                  -n/n = Value at POR and BOR/Value at all other Resets  
'1' = Bit is set                            '0' = Bit is cleared

- bit 7            **HxFES:** Hardware Limit Timerx Falling Edge Sensitivity bit  
1 = Edge sensitive  
0 = Level sensitive
- bit 6            **HxRES:** Hardware Limit Timerx Rising Edge Sensitivity bit  
1 = Edge sensitive  
0 = Level sensitive
- bit 5            **Unimplemented:** Read as '0'
- bit 4-2        **HxERS<2:0>:** Hardware Limit Timerx External Reset Source Select bits  
000 = CCP1 Out  
001 = C1OUT  
010 = C2OUT  
011 = COG1FLT  
100 = COG1OUT0  
101 = COG1OUT1  
110 = Reserved - '0' input  
111 = Reserved - '0' input
- bit 1            **HxFEREN:** Hardware Limit Timerx Falling Event Reset Enable bit  
1 = HLTMRx will reset on the first clock after a falling event of selected Reset source  
0 = Falling events of selected source have no effect
- bit 0            **HxREREN:** Hardware Limit Timerx Rising Event Reset Enable bit  
1 = HLTMRx will reset on the first clock after a rising event of selected Reset source  
0 = Rising events of selected source have no effect

**TABLE 9-1: SUMMARY OF REGISTERS ASSOCIATED WITH HLT**

Name	Bit 7	Bit 6	Bit 5	Bit 4	Bit 3	Bit 2	Bit 1	Bit 0	Register on Page
CCP1CON	—	—	DC1B<1:0>		CCP1M<3:0>				87
CM1CON0	C1ON	C1OUT	C1OE	C1POL	C1ZLF	C1SP	C1HYS	C1SYNC	139
CM1CON1	C1INTP	C1INTN	C1PCH<2:0>			C1NCH<2:0>			140
CM2CON0	C2ON	C2OUT	C2OE	C2POL	C2ZLF	C2SP	C2HYS	C2SYNC	139
CM2CON1	C2INTP	C2INTN	C2PCH<2:0>			C2NCH<2:0>			140
INTCON	GIE	PEIE	TOIE	INTE	IOCFIE	TOIF	INTF	IOCFIF	19
PIE1	TMR1GIE	ADIE	—	—	HLTMR2IE	HLTMR1IE	TMR2IE	TMR1IE	20
PIR1	TMR1GIF	ADIF	—	—	HLTMR2IF	HLTMR1IF	TMR2IF	TMR1IF	22
HLTMRx	Holding Register for the 8-bit Hardware Limit TimerX Count								77*
HLTPRx	HLTMRx Module Period Register								77*
HLTxCAN0	—	HxOUTPS<3:0>				HxON	HxCKPS<1:0>		79
HLTxCAN1	HxFES	HxRES	—	HxERS<2:0>			HxFEREN	HxREREN	80

**Legend:** — = unimplemented location, read as '0'. Shaded cells do not affect the HLT module operation.  
\* Page provides register information.



## 10.0 CAPTURE/COMPARE/PWM MODULES

The Capture/Compare/PWM module is a peripheral which allows the user to time and control different events, and to generate Pulse-Width Modulation (PWM) signals. In Capture mode, the peripheral allows the timing of the duration of an event. The Compare mode allows the user to trigger an external event when a predetermined amount of time has expired. The PWM mode can generate Pulse-Width Modulated signals of varying frequency and duty cycle.

### 10.1 Capture Mode

Capture mode makes use of the 16-bit Timer1 resource. When an event occurs on the CCP1 pin, the 16-bit CCPR1H:CCPR1L register pair captures and stores the 16-bit value of the TMR1H:TMR1L register pair, respectively. An event is defined as one of the following and is configured by the CCP1M<3:0> bits of the CCP1CON register:

- Every falling edge
- Every rising edge
- Every 4th rising edge
- Every 16th rising edge

When a capture is made, the Interrupt Request Flag bit CCP1IF of the PIR2 register is set. The interrupt flag must be cleared in software. If another capture occurs before the value in the CCPR1H, CCPR1L register pair is read, the old captured value is overwritten by the new captured value.

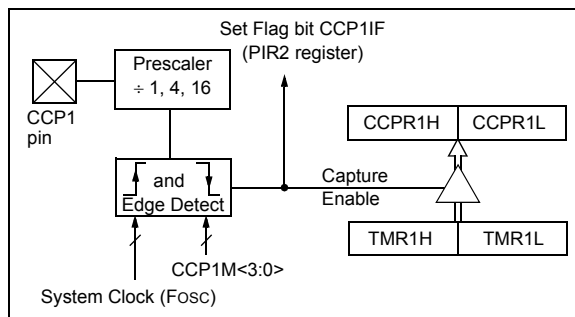
Figure 10-1 shows a simplified diagram of the Capture operation.

#### 10.1.1 CCP1 PIN CONFIGURATION

In Capture mode, the CCP1 pin should be configured as an input by setting the associated TRIS control bit.

**Note:** If the CCP1 pin is configured as an output, a write to the port can cause a capture condition.

**FIGURE 10-1: CAPTURE MODE OPERATION BLOCK DIAGRAM**



#### 10.1.2 TIMER1 MODE RESOURCE

Timer1 must be running in Timer mode or Synchronized Counter mode for the CCP1 module to use the capture feature. In Asynchronous Counter mode, the capture operation may not work.

See Section 7.0 “Timer1 Module with Gate Control” for more information on configuring Timer1.

#### 10.1.3 SOFTWARE INTERRUPT MODE

When the Capture mode is changed, a false capture interrupt may be generated. The user should keep the CCP1IE interrupt enable bit of the PIE2 register clear to avoid false interrupts. Additionally, the user should clear the CCP1IF interrupt flag bit of the PIR2 register following any change in Operating mode.

**Note:** Clocking Timer1 from the system clock (Fosc) should not be used in Capture mode. In order for Capture mode to recognize the trigger event on the CCP1 pin, Timer1 must be clocked from the instruction clock (Fosc/4) or from an external clock source.

#### 10.1.4 CCP1 PRESCALER

There are four prescaler settings specified by the CCP1M<3:0> bits of the CCP1CON register. Whenever the CCP1 module is turned off, or the CCP1 module is not in Capture mode, the prescaler counter is cleared. Any Reset will clear the prescaler counter.

Switching from one capture prescaler to another does not clear the prescaler and may generate a false interrupt. To avoid this unexpected operation, turn the module off by clearing the CCP1CON register before changing the prescaler. Example 10-1 demonstrates the code to perform this function.

#### EXAMPLE 10-1: CHANGING BETWEEN CAPTURE PRESCALERS

```
BANKSEL CCP1CON    ;Set Bank bits to point
                   ;to CCP1CON
CLRF    CCP1CON    ;Turn CCP1 module off
MOVLW  NEW_CAPT_PS;Load the W reg with
                   ;the new prescaler
MOVWF  CCP1CON    ;move value and CCP1 ON
                   ;Load CCP1CON with this
                   ;value
```

# PIC16F753/HV753

## 10.1.5 CAPTURE DURING SLEEP

Capture mode depends upon the Timer1 module for proper operation. If the Timer1 clock input source is a clock that is not disabled during Sleep, Timer1 will continue to operate and Capture mode will operate during Sleep to wake the device. The T1CKI is an example of a clock source that will operate during Sleep.

When the input source to Timer1 is disabled during Sleep, such as the HFINTOSC, Timer1 will not increment during Sleep. When the device wakes from Sleep, Timer1 will continue from its previous state.

**TABLE 10-1: SUMMARY OF REGISTERS ASSOCIATED WITH CAPTURE**

Name	Bit 7	Bit 6	Bit 5	Bit 4	Bit 3	Bit 2	Bit 1	Bit 0	Register on Page
CCP1CON	—	—	DC1B<1:0>		CCP1M<3:0>				87
CCPR1L	CCPR1L<7:0>								81
CCPR1H	CCPR1H<7:0>								81
INTCON	GIE	PEIE	T0IE	INTE	IOCFE	T0IF	INTF	IOCF	19
PIE1	TMR1GIE	ADIE	—	—	HLTMR2IE	HLTMR1IE	TMR2IE	TMR1IE	20
PIE2	—	—	C2IE	C1IE	—	COG1IE	—	CCP1IE	21
PIR1	TMR1GIF	ADIF	—	—	HLTMR2IF	HLTMR1IF	TMR2IF	TMR1IF	22
PIR2	—	—	C2IF	C1IF	—	COG1IF	—	CCP1IF	23
T1CON	TMR1CS<1:0>		T1CKPS<1:0>		T1OSCEN	T1SYNC	—	TMR1ON	71
T1GCON	TMR1GE	T1GPOL	T1GTM	T1GSPM	T1GGO/ DONE	T1GVAL	T1GSS<1:0>		72
TMR1H	TMR1H<7:0>								63*
TMR1L	TMR1L<7:0>								63*
TRISA	—	—	TRISA5	TRISA4	TRISA3 <sup>(1)</sup>	TRISA2	TRISA1	TRISA0	46

**Legend:** — = Unimplemented location, read as '0'. Shaded cells are not used by Capture mode.

\* Page provides register information.

**Note 1:** TRISA3 always reads '1'.

## 10.2 Compare Mode

Compare mode makes use of the 16-bit Timer1 resource. The 16-bit value of the CCPR1H:CCPR1L register pair is constantly compared against the 16-bit value of the TMR1H:TMR1L register pair. When a match occurs, one of the following events can occur:

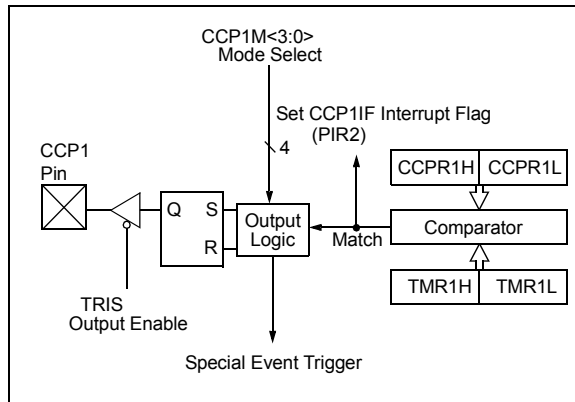
- Toggle the CCP1 output
- Set the CCP1 output
- Clear the CCP1 output
- Generate a Special Event Trigger
- Generate a Software Interrupt

The action on the pin is based on the value of the CCP1M<3:0> control bits of the CCP1CON register. At the same time, the interrupt flag CCP1IF bit is set.

All Compare modes can generate an interrupt.

Figure 10-2 shows a simplified diagram of the Compare operation.

**FIGURE 10-2: COMPARE MODE OPERATION BLOCK DIAGRAM**



### 10.2.1 CCP1 PIN CONFIGURATION

The user must configure the CCP1 pin as an output by clearing the associated TRIS bit.

**Note:** Clearing the CCP1CON register will force the CCP1 compare output latch to the default low level. This is not the PORT I/O data latch.

### 10.2.2 TIMER1 MODE RESOURCE

In Compare mode, Timer1 must be running in either Timer mode or Synchronized Counter mode. The compare operation may not work in Asynchronous Counter mode.

See Section 7.0 “Timer1 Module with Gate Control” for more information on configuring Timer1.

**Note:** Clocking Timer1 from the system clock (FOSC) should not be used in Compare mode. In order for Compare mode to recognize the trigger event on the CCP1 pin, Timer1 must be clocked from the instruction clock (FOSC/4) or from an external clock source.

### 10.2.3 SOFTWARE INTERRUPT MODE

When Generate Software Interrupt mode is chosen (CCP1M<3:0> = 1010), the CCP1 module does not assert control of the CCP1 pin (see the CCP1CON register).

### 10.2.4 SPECIAL EVENT TRIGGER

When Special Event Trigger mode is chosen (CCP1M<3:0> = 1011), the CCP1 module does the following:

- Resets Timer1
- Starts an ADC conversion if ADC is enabled

The CCP1 module does not assert control of the CCP1 pin in this mode.

The Special Event Trigger output of the CCP1 occurs immediately upon a match between the TMR1H, TMR1L register pair and the CCPR1H, CCPR1L register pair. The TMR1H, TMR1L register pair is not reset until the next rising edge of the Timer1 clock. The Special Event Trigger output starts an A/D conversion (if the A/D module is enabled). This allows the CCPR1H, CCPR1L register pair to effectively provide a 16-bit programmable period register for Timer1.

**TABLE 10-2: SPECIAL EVENT TRIGGER**

Device	CCP1
PIC16F753	CCP1
PIC16HV753	CCP1

Refer to Section 12.0 “Analog-to-Digital Converter (ADC) Module” for more information.

- Note 1:** The Special Event Trigger from the CCP module does not set interrupt flag bit TMR1IF of the PIR1 register.
- 2:** Removing the match condition by changing the contents of the CCPR1H and CCPR1L register pair, between the clock edge that generates the Special Event Trigger and the clock edge that generates the Timer1 Reset, will preclude the Reset from occurring.

# PIC16F753/HV753

## 10.2.5 COMPARE DURING SLEEP

The Compare mode is dependent upon the system clock (Fosc) for proper operation. Since Fosc is shut down during Sleep mode, the Compare mode will not function properly during Sleep.

**TABLE 10-3: SUMMARY OF REGISTERS ASSOCIATED WITH COMPARE**

Name	Bit 7	Bit 6	Bit 5	Bit 4	Bit 3	Bit 2	Bit 1	Bit 0	Register on Page
CCP1CON	—	—	DC1B<1:0>		CCP1M<3:0>				87
CCPR1L	CCPR1L<7:0>								81
CCPR1H	CCPR1H<7:0>								81
INTCON	GIE	PEIE	T0IE	INTE	IOCIE	T0IF	INTF	IOCF	19
PIE1	TMR1GIE	ADIE	—	—	HLTMR2IE	HLTMR1IE	TMR2IE	TMR1IE	20
PIE2	—	—	C2IE	C1IE	—	COG1IE	—	CCP1IE	21
PIR1	TMR1GIF	ADIF	—	—	HLTMR2IF	HLTMR1IF	TMR2IF	TMR1IF	22
PIR2	—	—	C2IF	C1IF	—	COG1IF	—	CCP1IF	23
T1CON	TMR1CS<1:0>		T1CKPS<1:0>		T1OSCEN	T1SYNC	—	TMR1ON	71
T1GCON	TMR1GE	T1GPOL	T1GTM	T1GSPM	T1GGO/ DONE	T1GVAL	T1GSS<1:0>		72
TMR1H	TMR1H<7:0>								63*
TMR1L	TMR1L<7:0>								63*
TRISA	—	—	TRISA5	TRISA4	TRISA3 <sup>(1)</sup>	TRISA2	TRISA1	TRISA0	46

**Legend:** — = Unimplemented location, read as '0'. Shaded cells are not used by Compare mode.

\* Page provides register information.

**Note 1:** TRISA3 always reads '1'.

## 10.3 PWM Overview

Pulse-Width Modulation (PWM) is a scheme that provides power to a load by switching quickly between fully on and fully off states. The PWM signal resembles a square wave where the high portion of the signal is considered the on state and the low portion of the signal is considered the off state. The high portion, also known as the pulse width, can vary in time and is defined in steps. A larger number of steps applied, which lengthens the pulse width, also supplies more power to the load. Lowering the number of steps applied, which shortens the pulse width, supplies less power. The PWM period is defined as the duration of one complete cycle or the total amount of on and off time combined.

PWM resolution defines the maximum number of steps that can be present in a single PWM period. A higher resolution allows for more precise control of the pulse width time and in turn the power that is applied to the load.

The term duty cycle describes the proportion of the on time to the off time and is expressed in percentages, where 0% is fully off and 100% is fully on. A lower duty cycle corresponds to less power applied and a higher duty cycle corresponds to more power applied.

Figure 10-3 shows a typical waveform of the PWM signal.

### 10.3.1 STANDARD PWM OPERATION

The standard PWM mode generates a Pulse-Width Modulation (PWM) signal on the CCP1 pin with up to 10 bits of resolution. The period, duty cycle, and resolution are controlled by the following registers:

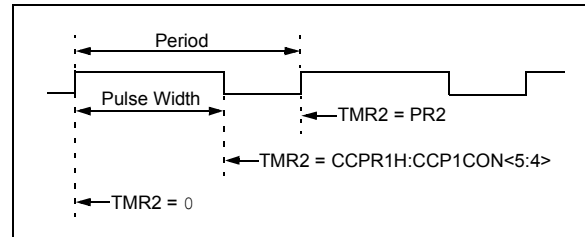
- PR2 registers
- T2CON registers
- CCPR1L registers
- CCP1CON registers

Figure 10-4 shows a simplified block diagram of PWM operation.

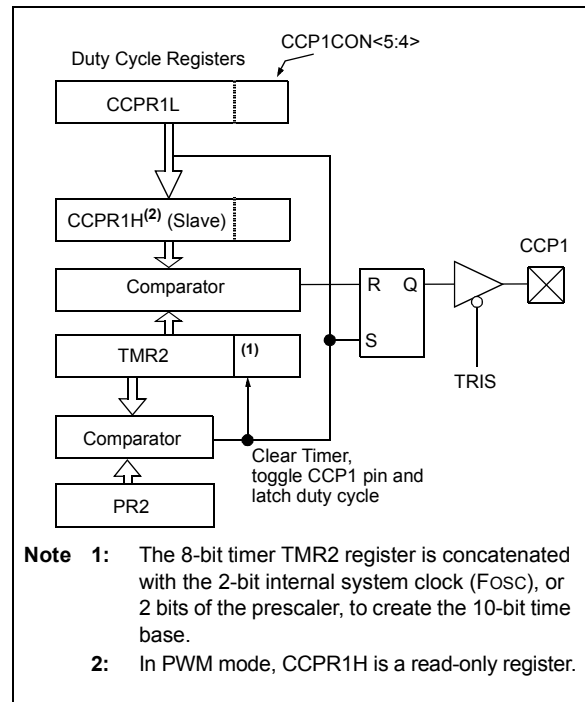
**Note 1:** The corresponding TRIS bit must be cleared to enable the PWM output on the CCP1 pin.

**2:** Clearing the CCP1CON register will relinquish control of the CCP1 pin.

**FIGURE 10-3: CCP1 PWM OUTPUT SIGNAL**



**FIGURE 10-4: SIMPLIFIED PWM BLOCK DIAGRAM**



# PIC16F753/HV753

## 10.3.2 SETUP FOR PWM OPERATION

The following steps should be taken when configuring the CCP1 module for standard PWM operation:

1. Disable the CCP1 pin output driver by setting the associated TRIS bit.
2. Load the PR2 register with the PWM period value.
3. Configure the CCP1 module for the PWM mode by loading the CCP1CON register with the appropriate values.
4. Load the CCPR1L register and the DC1B<1:0> bits of the CCP1CON register, with the PWM duty cycle value.
5. Configure and start Timer2:
  - Clear the TMR2IF interrupt flag bit of the PIR1 register. See Note below.
  - Configure the T2CKPS bits of the T2CON register with the Timer prescale value.
  - Enable the Timer by setting the TMR2ON bit of the T2CON register.
6. Enable PWM output pin:
  - Wait until the Timer overflows and the TMR2IF bit of the PIR1 register is set. See Note below.
  - Enable the CCP1 pin output driver by clearing the associated TRIS bit.

**Note:** In order to send a complete duty cycle and period on the first PWM output, the above steps must be included in the setup sequence. If it is not critical to start with a complete PWM signal on the first output, then step 6 may be ignored.

## 10.3.3 PWM PERIOD

The PWM period is specified by the PR2 register of Timer2. The PWM period can be calculated using the formula of [Equation 10-1](#).

### EQUATION 10-1: PWM PERIOD

$$PWM\ Period = [(PR2) + 1] \cdot 4 \cdot TOSC \cdot (TMR2\ Prescale\ Value)$$

**Note 1:**  $TOSC = 1/FOSC$

When TMR2 is equal to PR2, the following three events occur on the next increment cycle:

- TMR2 is cleared
- The CCP1 pin is set. (Exception: If the PWM duty cycle = 0%, the pin will not be set.)
- The PWM duty cycle is latched from CCPR1L into CCPR1H.

**Note:** The Timer postscale (see [Section 8.1 “Timer2 Operation”](#)) is not used in the determination of the PWM frequency.

## 10.3.4 PWM DUTY CYCLE

The PWM duty cycle is specified by writing a 10-bit value to multiple registers: CCPR1L register and DC1B<1:0> bits of the CCP1CON register. The CCPR1L contains the eight MSBs and the DC1B<1:0> bits of the CCP1CON register contain the two LSBs. CCPR1L and DC1B<1:0> bits of the CCP1CON register can be written to at any time. The duty cycle value is not latched into CCPR1H until after the period completes (i.e., a match between PR2 and TMR2 registers occurs). While using the PWM, the CCPR1H register is read-only.

[Equation 10-2](#) is used to calculate the PWM pulse width.

[Equation 10-3](#) is used to calculate the PWM duty cycle ratio.

### EQUATION 10-2: PULSE WIDTH

$$Pulse\ Width = (CCPR1L:CCP1CON<5:4>) \cdot TOSC \cdot (TMR2\ Prescale\ Value)$$

### EQUATION 10-3: DUTY CYCLE RATIO

$$Duty\ Cycle\ Ratio = \frac{(CCPRxL:CCPxCON<5:4>)}{4(PR_x + 1)}$$

The CCPR1H register and a 2-bit internal latch are used to double buffer the PWM duty cycle. This double buffering is essential for glitchless PWM operation.

The 8-bit timer TMR2 register is concatenated with either the 2-bit internal system clock (FOSC), or 2 bits of the prescaler, to create the 10-bit time base. The system clock is used if the Timer2 prescaler is set to 1:1.

When the 10-bit time base matches the CCPR1H and 2-bit latch, then the CCP1 pin is cleared (see [Figure 10-4](#)).

## 10.4 Register Definitions: CCP Control

**REGISTER 10-1: CCP1CON: CCP1 CONTROL REGISTER**

U-0	U-0	R/W-0/0	R/W-0/0	R/W-0/0	R/W-0/0	R/W-0/0	R/W-0/0	
—	—	DC1B<1:0>		CCP1M<3:0>				
bit 7								bit 0

**Legend:**

R = Readable bit	W = Writable bit	U = Unimplemented bit, read as '0'
u = Bit is unchanged	x = Bit is unknown	-n/n = Value at POR and BOR/Value at all other Reset
'1' = Bit is set	'0' = Bit is cleared	

bit 7-6 **Unimplemented:** Read as '0'

bit 5-4 **DC1B<1:0>:** PWM Duty Cycle Least Significant bits

Capture mode:

Unused

Compare mode:

Unused

PWM mode:

These bits are the two LSBs of the PWM duty cycle. The eight MSBs are found in CCP1L.

bit 3-0 **CCP1M<3:0>:** CCP1 Mode Select bits

0000 = Capture/Compare/PWM off (resets CCP1 module)

0001 = Reserved

0010 = Compare mode: toggle output on match

0011 = Reserved

0100 = Capture mode: every falling edge

0101 = Capture mode: every rising edge

0110 = Capture mode: every 4th rising edge

0111 = Capture mode: every 16th rising edge

1000 = Compare mode: initialize CCP1 pin low; set output on compare match (set CCP1IF)

1001 = Compare mode: initialize CCP1 pin high; clear output on compare match (set CCP1IF)

1010 = Compare mode: generate software interrupt only; CCP1 pin reverts to I/O state

1011 = Compare mode: Special Event Trigger (CCP1 resets Timer, sets CCP1IF bit, and starts A/D conversion if A/D module is enabled)

11xx = PWM mode

# PIC16F753/HV753

---

NOTES:



## 11.0 COMPLEMENTARY OUTPUT GENERATOR (COG) MODULE

The primary purpose of the Complementary Output Generator (COG) is to convert a single output PWM signal into a two output complementary PWM signal. The COG can also convert two separate input events into a single or complementary PWM output.

The COG PWM frequency and duty cycle are determined by a rising event input and a falling event input. The rising event and falling event may be the same source. Sources may be synchronous or asynchronous to the COG\_clock.

The rate at which the rising event occurs determines the PWM frequency. The time from the rising event input to the falling event input determines the duty cycle.

A selectable clock input is used to generate the phase delay, blanking and dead-band times.

A simplified block diagram of the COG is shown in [Figure 11-1](#).

The COG module has the following features:

- Two modes of operation:
  - Synchronous PWM
  - Push-pull
- Selectable clock source
- Independently selectable rising event sources
- Independently selectable falling event sources
- Independently selectable edge or level event sensitivity
- Independent output enables
- Independent output polarity selection
- Phase delay with independent rising and falling delay times
- Dead-band control with:
  - Independent rising and falling event dead-band times
  - Synchronous and asynchronous timing
- Blanking control with independent rising and falling event blanking times
- Auto-shutdown control with:
  - Independently selectable shutdown sources
  - Auto-restart enable
  - Auto-shutdown pin override control (high, low, off, and High-Z)

### 11.1 Fundamental Operation

#### 11.1.1 SYNCHRONOUS PWM MODE

In synchronous PWM mode, the COG generates a two output complementary PWM waveform from rising and falling event sources. In the simplest configuration, the rising and falling event sources have the same signal, which is a PWM signal with the desired period and duty

cycle. The COG converts this single PWM input into a dual complementary PWM output. The frequency and duty cycle of the dual PWM output match those of the single input PWM signal. The off-to-on transition of each output can be delayed from the on-to-off transition of the other output, thereby creating a time immediately after the PWM transition where neither output is driven. This is referred to as dead time and is covered in [Section 11.5 “Dead-Band Control”](#).

A typical operating waveform, with dead band, generated from a single CCP1 input is shown in [Figure 11-4](#).

#### 11.1.2 PUSH-PULL MODE

In Push-Pull mode, the COG generates a single PWM output that alternates every PWM period, between the two COG output pins. The output drive activates with the rising input event and terminates with the falling event input. Each rising event starts a new period and causes the output to switch to the COG pin not used in the previous period.

A typical push-pull waveform generated from a single CCP1 input is shown in [Figure 11-6](#).

Push-Pull mode is selected by setting the GxMD bit of the COGxCON0 register.

#### 11.1.3 ALL MODES

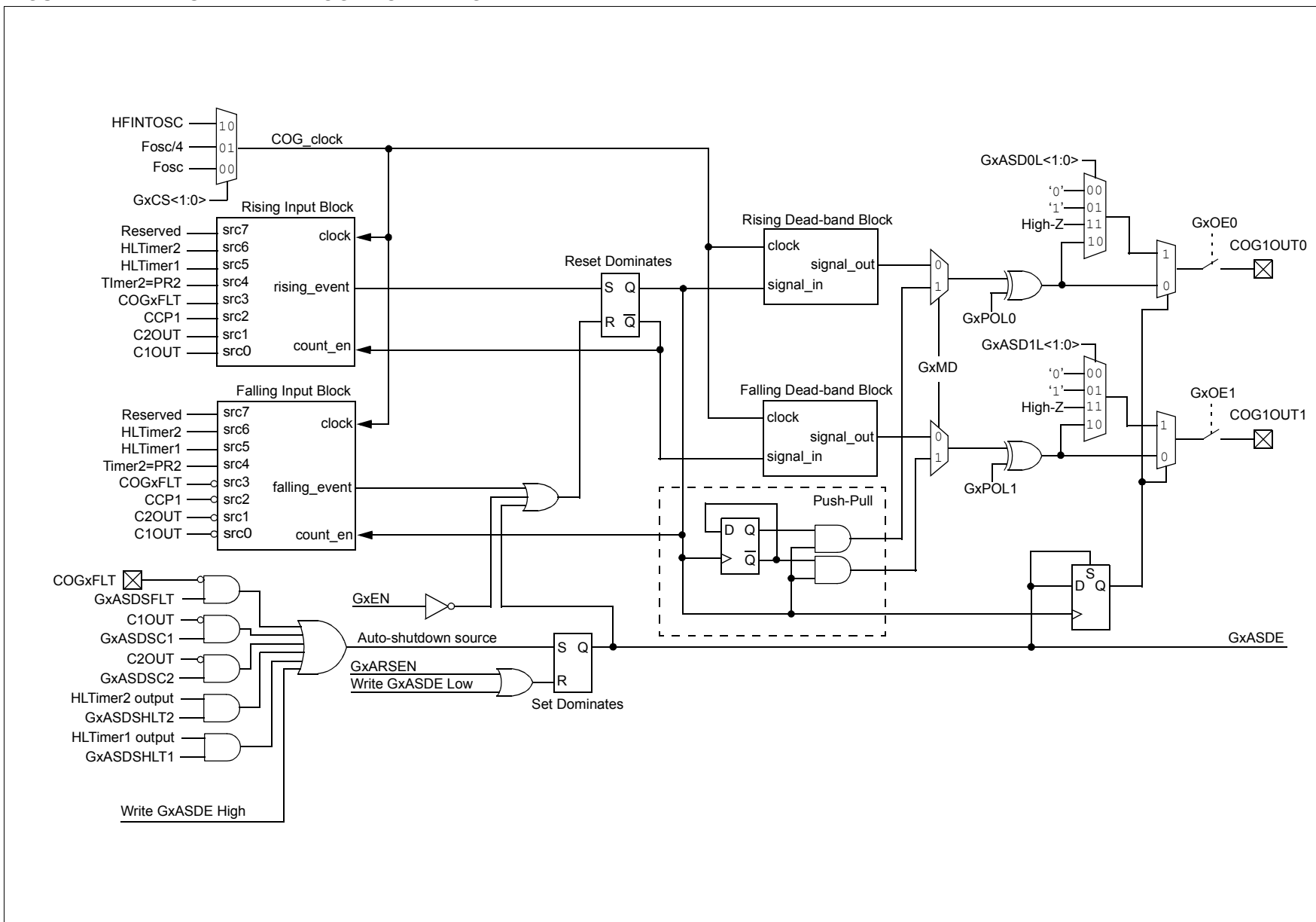
In addition to generating a complementary output from a single PWM input, the COG can also generate PWM waveforms from a periodic rising event and a separate falling event. In this case, the falling event is usually derived from analog feedback within the external PWM driver circuit. In this configuration, high-power switching transients may trigger a false falling event that needs to be blanked out. The COG can be configured to blank falling (and rising) event inputs for a period of time immediately following the rising (and falling) event drive output. This is referred to as input blanking and is described in [Section 11.6 “Blanking Control”](#).

It may be necessary to guard against the possibility of circuit faults. In this case, the active drive must be terminated before the Fault condition causes damage. This is referred to as auto-shutdown and is described in [Section 11.8 “Auto-shutdown Control”](#).

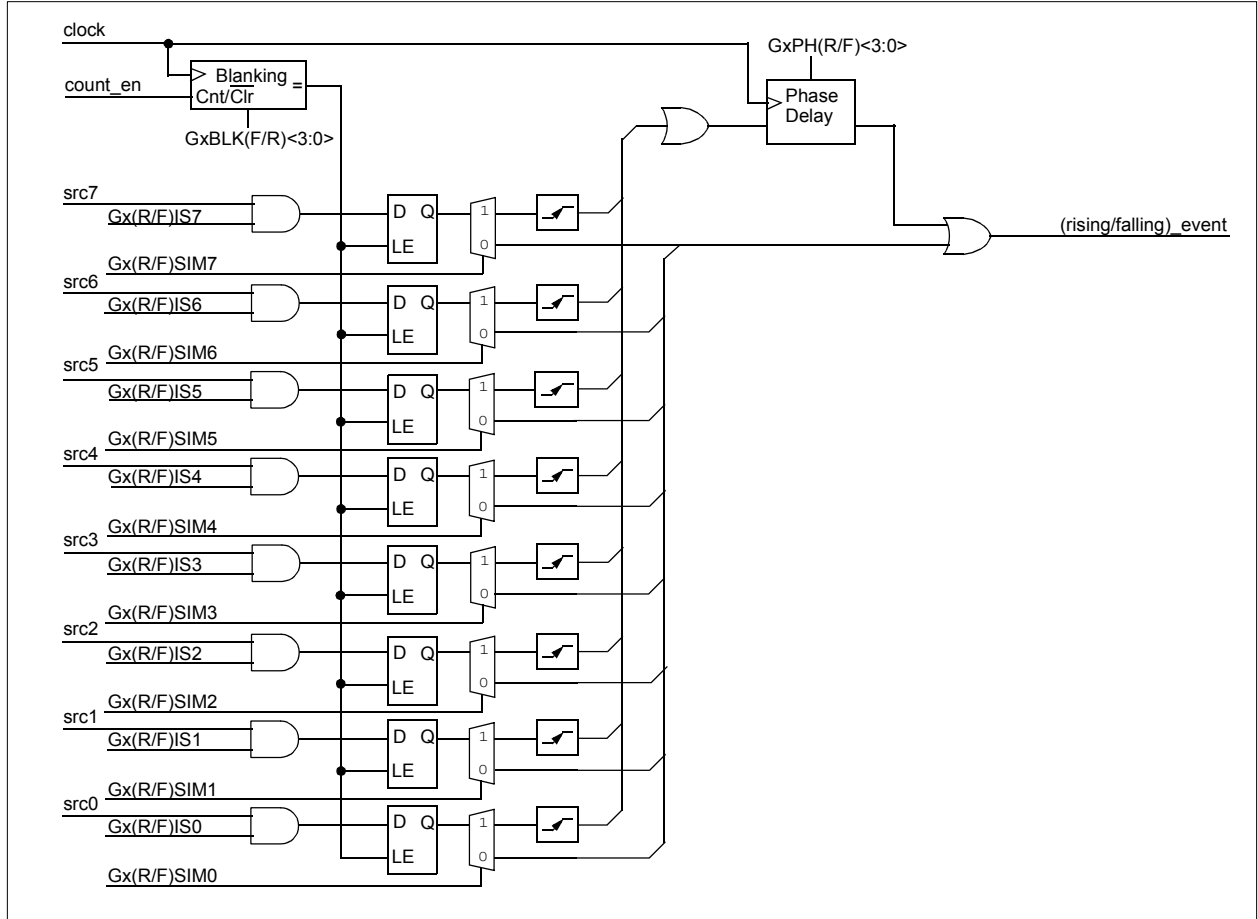
A feedback falling event arriving too late or not at all can be terminated with auto-shutdown or by enabling one of the Hardware Limit Timer (HLT) event inputs. See [Section 9.0 “Hardware Limit Timer \(HLT\) Module”](#) for more information about the HLT.

The COG can be configured to operate in phase delayed conjunction with another PWM. The active drive cycle is delayed from the rising event by a phase delay timer. Phase delay is covered in more detail in [Section 11.7 “Phase Delay”](#). A typical operating waveform, with phase delay and dead band, generated from a single CCP1 input, is shown in [Figure 11-5](#).

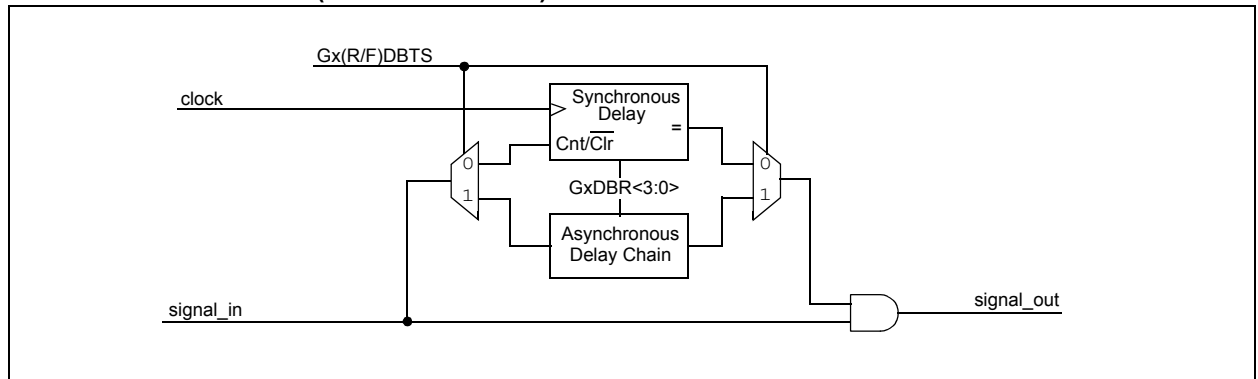
FIGURE 11-1: SIMPLIFIED COG BLOCK DIAGRAM



**FIGURE 11-2: COG (RISING/FALLING) INPUT BLOCK**

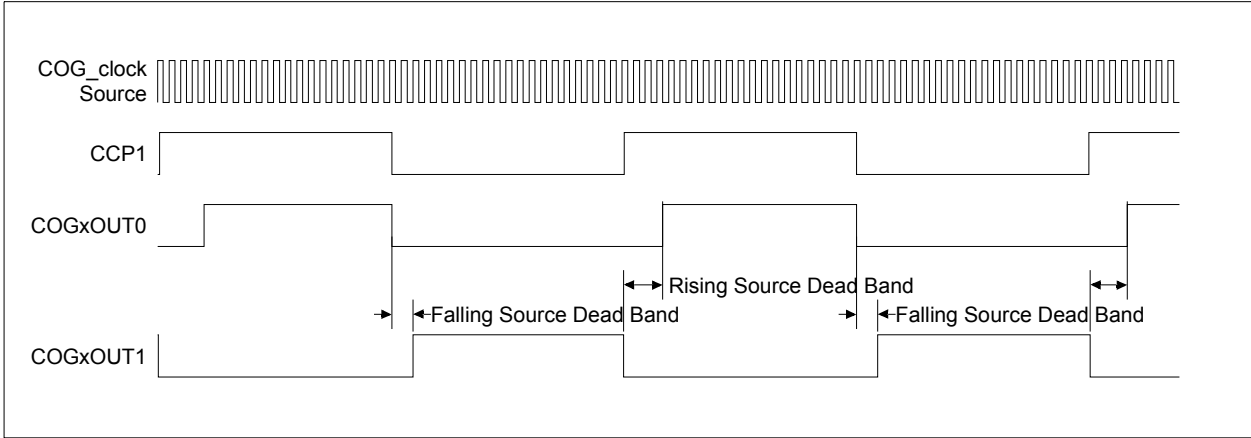


**FIGURE 11-3: COG (RISING/FALLING) DEAD-BAND BLOCK**

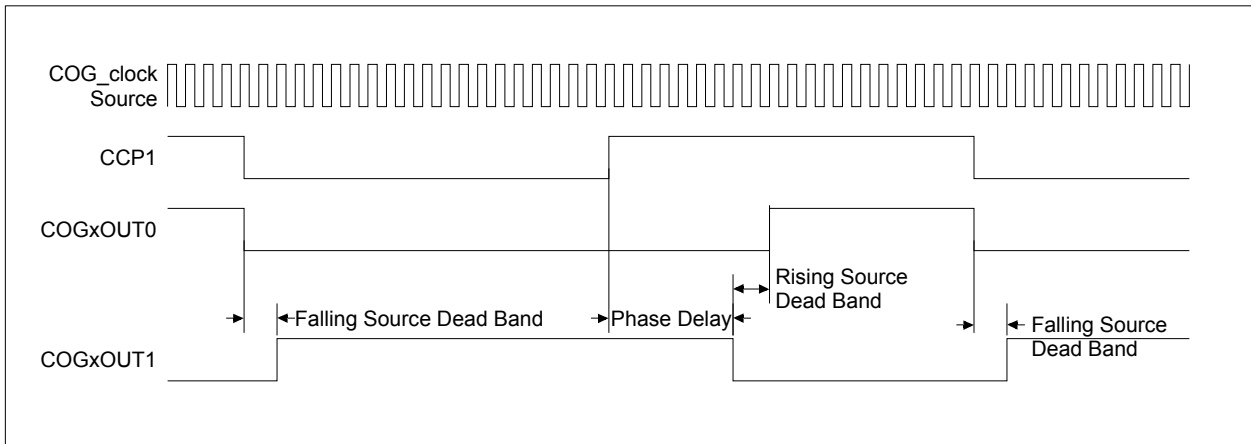


# PIC16F753/HV753

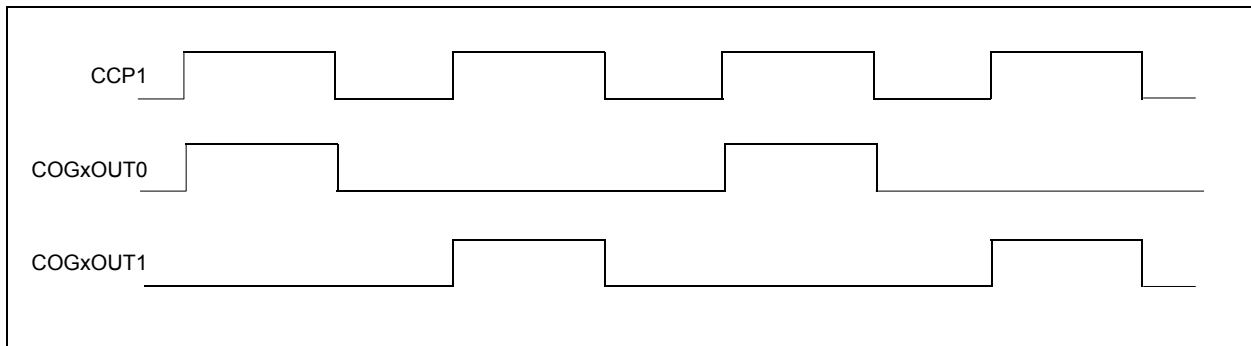
**FIGURE 11-4: TYPICAL COG OPERATION WITH CCP1**



**FIGURE 11-5: COG OPERATION WITH CCP1 AND PHASE DELAY**



**FIGURE 11-6: COG OPERATION IN PUSH-PULL MODE WITH CCP1**



## 11.2 Clock Sources

The COG\_clock is used as the reference clock to the various timers in the peripheral. Timers that use the COG\_clock include:

- Rising and falling dead-band time
- Rising and falling blanking time
- Rising and falling event phase delay

Clock sources available for selection include:

- 8 MHz HFINTOSC (active during Sleep)
- Instruction clock (Fosc/4)
- System clock (Fosc)

The clock source is selected with the GxCS<1:0> bits of the COGxCON1 register (Register 11-2).

## 11.3 Selectable Event Sources

The COG uses any combination of independently selectable event sources to generate the complementary waveform. Sources fall into two categories:

- Rising event sources
- Falling event sources

The rising event sources are selected by setting bits in the COGxRIS register (Register 11-3). The falling event sources are selected by setting bits in the COGxFIS register (Register 11-5). All selected sources are 'OR'd together to generate the corresponding event signal. Refer to Figure 11-2.

### 11.3.1 EDGE VS. LEVEL SENSING

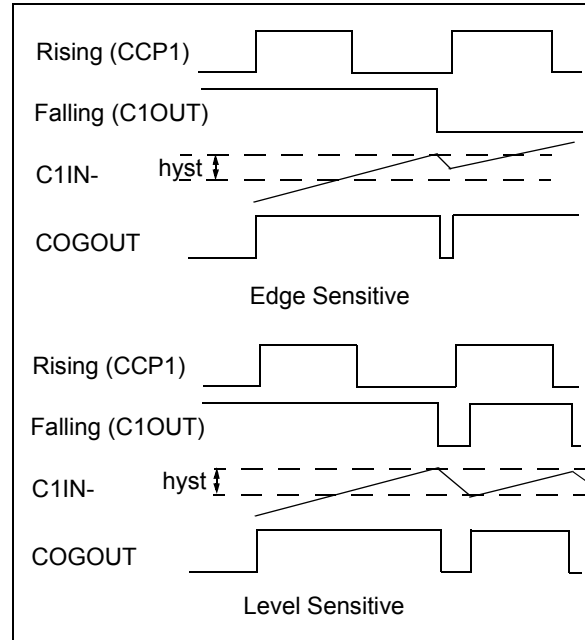
Event input detection may be selected as level or edge-sensitive. The Detection mode is individually selectable for every source. Rising source detection modes are selected with the COGxRSIM register (Register 11-4). Falling source detection modes are selected with the COGxFSIM register (Register 11-6). A set bit enables edge detection for the corresponding event source. A cleared bit enables level detection.

In general, events that are driven from a periodic source should be edge-detected and events that are derived from voltage thresholds at the target circuit should be level-sensitive. Consider the following two examples:

1. The first example is an application in which the period is determined by a 50% duty cycle clock and the COG output duty cycle is determined by a voltage level fed back through a comparator. If the clock input is level sensitive, duty cycles less than 50% will exhibit erratic operation.
2. The second example is similar to the first, except that the duty cycle is close to 100%. The feedback comparator high-to-low transition trips the COG drive off, but almost immediately the period source turns the drive back on. If the off cycle is short enough, the comparator input may not reach the low side of the hysteresis band precluding an output change. The comparator

output stays low and without a high-to-low transition to trigger the edge sense, the drive of the COG output will be stuck in a constant drive-on condition. See Figure 11-7.

**FIGURE 11-7: EDGE VS. LEVEL SENSE**



### 11.3.2 RISING EVENT

The rising event starts the PWM output active duty cycle period. The rising event is the low-to-high transition of the rising\_event output. When the rising event phase delay and dead-band time values are zero, the COGxOUT0 output starts immediately. Otherwise, the COGxOUT0 output is delayed. The rising event source causes all the following actions:

- Start rising event phase delay counter (if enabled).
- Clear COGxOUT1 after phase delay.
- Start falling event input blanking (if enabled).
- Start dead-band delay (if enabled).
- Set COGxOUT0 output after dead-band delay expires.

### 11.3.3 FALLING EVENT

The falling event terminates the PWM output active duty cycle period. The falling event is the high-to-low transition of the falling\_event output. When the falling event phase delay and dead-band time values are zero, the COGxOUT1 output starts immediately. Otherwise, the COGxOUT1 output is delayed. The falling event source causes all the following actions:

- Start falling event phase delay counter (if enabled).
- Clear COGxOUT0.
- Start rising event input blanking (if enabled).
- Start falling event dead-band delay (if enabled).
- Set COGxOUT1 output after dead-band delay expires.

# PIC16F753/HV753

---

## 11.4 Output Control

Upon disabling, or immediately after enabling the COG module, the complementary drive is configured with COGxOUT0 drive inactive and COGxOUT1 drive active.

### 11.4.1 OUTPUT ENABLES

Each COG output pin has an individual output enable control. Output enables are selected with the GxOE0 and GxOE1 bits of the COGxCON0 register ([Register 11-1](#)). When an output enable control is cleared, the module asserts no control over the pin. When an output enable is set, the override value or PWM waveform is applied to the pin per the port priority selection.

The device pin output enable control bits are independent of the GxEN bit of the COGxCON0 register, which enables the COG. When GxEN is cleared, and shutdown is not active, the Reset state PWM levels are present on the COG output pins. The PWM levels are affected by the polarity controls. If shutdown is active when GxEN is cleared, the shutdown override levels will be present on the COG output pins. Note that setting the GxASE bit while the GxEN bit is cleared will activate shutdown which can only be cleared by either a rising event while the GxEN bit is set, or a device Reset.

### 11.4.2 POLARITY CONTROL

The polarity of each COG output can be selected independently. When the output polarity bit is set, the corresponding output is active-low. Clearing the output polarity bit configures the corresponding output as active-high. However, polarity does not affect the shutdown override levels.

Output polarity is selected with the GxPOL0 and GxPOL1 bits of the COGxCON0 register ([Register 11-1](#)).

## 11.5 Dead-Band Control

The dead-band control provides for non-overlapping PWM output signals to prevent shoot-through current in the external power switches.

The COG contains two dead-band timers. One dead-band timer is used for rising event dead-band control. The other is used for falling event dead-band control. Timer modes are selectable as either:

- Asynchronous delay chain
- Synchronous counter

The dead-band Timer mode is selected for the COGxOUT0 and COGxOUT1 dead-band times with the respective GxRDBTS and GxFDBTS bits of the COGxCON1 register ([Register 11-2](#)).

### 11.5.1 ASYNCHRONOUS DELAY CHAIN DEAD-BAND DELAY

Asynchronous dead-band delay is determined by the time it takes the input to propagate through a series of delay elements. Each delay element is a nominal five nanoseconds.

Set the COGxDBR register ([Register 11-9](#)) value to the desired number of delay elements in the COGxOUT0 dead band. Set the COGxDBF register ([Register 11-10](#)) value to the desired number of delay elements in the COGxOUT1 dead band. When the value is zero, dead-band delay is disabled.

### 11.5.2 SYNCHRONOUS COUNTER DEAD-BAND DELAY

Synchronous counter dead band is timed by counting COG\_clock periods from zero up to the value in the dead-band count register. Use [Equation 11-1](#) to calculate dead-band times.

Set the COGxDBR count register value to obtain the desired dead-band time of the COGxOUT0 output. Set the COGxDBF count register value to obtain the desired dead-band time of the COGxOUT1 output. When the value is zero, dead-band delay is disabled.

### 11.5.3 SYNCHRONOUS COUNTER DEAD-BAND TIME UNCERTAINTY

When the rising and falling events that trigger the dead-band counters come from asynchronous inputs, it creates uncertainty in the synchronous counter dead-band time. The maximum uncertainty is equal to one COG\_clock period. Refer to [Equation 11-1](#) for more detail.

When event input sources are asynchronous with no phase delay, use the asynchronous delay chain dead-band mode to avoid the dead-band time uncertainty.

## 11.5.4 RISING EVENT DEAD BAND

Rising event dead band adds a delay between the COGxOUT1 signal deactivation and the COGxOUT0 signal activation. The rising event dead-band time starts when the rising\_event output goes true.

See [Section 11.5.1, Asynchronous Delay Chain Dead-band Delay](#) and [Section 11.5.2, Synchronous Counter Dead-band Delay](#) for more information on setting the rising edge dead-band time.

## 11.5.5 FALLING EVENT DEAD BAND

Falling event dead band adds a delay between the COGxOUT1 signal deactivation and the COGxOUT0 signal activation. The falling event dead-band time starts when the falling\_event output goes true.

See [Section 11.5.1, Asynchronous Delay Chain Dead-band Delay](#) and [Section 11.5.2, Synchronous Counter Dead-band Delay](#) for more information on setting the rising edge dead-band time.

## 11.5.6 DEAD-BAND OVERLAP

There are two cases of dead-band overlap:

- Rising-to-falling
- Falling-to-rising

### 11.5.6.1 Rising-to-Falling Overlap

In this case, the falling event occurs while the rising event dead-band counter is still counting. When this happens, the COGxOUT0 drive is suppressed and the dead band extends by the falling event dead-band time. At the termination of the extended dead-band time, the COGxOUT1 drive goes true.

### 11.5.6.2 Falling-to-Rising Overlap

In this case, the rising event occurs while the falling event dead-band counter is still counting. When this happens, the COGxOUT1 drive is suppressed and the dead band extends by the rising event dead-band time. At the termination of the extended dead-band time, the COGxOUT0 drive goes true.

## 11.6 Blanking Control

Input blanking is a function, whereby the event inputs can be masked or blanked for a short period of time. This is to prevent electrical transients caused by the turn-on/off of power components from generating a false input event.

The COG contains two blanking counters: one triggered by the rising event and the other triggered by the falling event. The counters are cross-coupled with the events they are blanking. The falling event blanking counter is used to blank rising input events and the rising event blanking counter is used to blank

falling input events. Once started, blanking extends for the time specified by the corresponding blanking counter.

Blanking is timed by counting COG\_clock periods from zero up to the value in the blanking count register. Use [Equation 11-1](#) to calculate blanking times.

## 11.6.1 FALLING EVENT BLANKING OF RISING EVENT INPUTS

The falling event blanking counter inhibits rising event inputs from triggering a rising event. The falling event blanking time starts when the rising event output drive goes false.

The falling event blanking time is set by the value contained in the COGxBLKF register ([Register 11-12](#)). Blanking times are calculated using the formula shown in [Equation 11-1](#).

When the COGxBLKF value is zero, the falling event blanking is disabled and the blanking counter output is true, thereby allowing the event signal to pass straight through to the event trigger circuit.

## 11.6.2 RISING EVENT BLANKING OF FALLING EVENT INPUTS

The rising event blanking counter inhibits falling event inputs from triggering a falling event. The rising event blanking time starts when the falling event output drive goes false.

The rising event blanking time is set by the value contained in the COGxBLKR register ([Register 11-11](#)).

When the COGxBLKR value is zero, the rising event blanking is disabled and the blanking counter output is true, thereby allowing the event signal to pass straight through to the event trigger circuit.

## 11.6.3 BLANKING TIME UNCERTAINTY

When the rising and falling sources that trigger the blanking counters are asynchronous to the COG\_clock, it creates uncertainty in the blanking time. The maximum uncertainty is equal to one COG\_clock period. Refer to [Equation 11-1](#) and [Example 11-2](#) for more detail.

## 11.7 Phase Delay

It is possible to delay the assertion of either or both the rising event and falling event. This is accomplished by placing a non-zero value in COGxPHR or COGxPHF phase delay count register, respectively ([Register 11-13](#) and [Register 11-14](#)). Refer to [Figure 11-5](#) for COG operation with CCP1 and phase delay. The delay from the input rising event signal switching to the actual assertion of the events is calculated the same as the dead-band and blanking delays. Please see [Equation 11-1](#).

# PIC16F753/HV753

When the phase delay count value is zero, phase delay is disabled and the phase delay counter output is true, thereby allowing the event signal to pass straight through to complementary output driver flop.

## 11.7.1 CUMULATIVE UNCERTAINTY

It is not possible to create more than one COG\_clock of uncertainty by successive stages. Consider that the phase delay stage comes after the blanking stage, the dead-band stage comes after either the blanking or phase delay stages, and the blanking stage comes after the dead-band stage. When the preceding stage is enabled, the output of that stage is necessarily synchronous with the COG\_clock, which removes any possibility of uncertainty in the succeeding stage.

### EQUATION 11-1: PHASE, DEAD-BAND AND BLANKING TIME CALCULATION

$$T_{\min} = \frac{\text{Count}}{F_{\text{COG\_clock}}}$$

$$T_{\max} = \frac{\text{Count} + 1}{F_{\text{COG\_clock}}}$$

$$T_{\text{uncertainty}} = T_{\max} - T_{\min}$$

Also:

$$T_{\text{uncertainty}} = \frac{1}{F_{\text{COG\_clock}}}$$

Where:

T	Count
Rising Phase Delay	COGxPHR
Falling Phase Delay	COGxPHF
Rising Dead Band	COGxDBR
Falling Dead Band	COGxDBF
Rising Event Blanking	COGxBLKR
Falling Event Blanking	COGxBLKF

### EQUATION 11-2: TIMER UNCERTAINTY

Given:

$$\text{Count} = Ah = 10d$$

$$F_{\text{COG\_Clock}} = 8\text{MHz}$$

Therefore:

$$T_{\text{uncertainty}} = \frac{1}{F_{\text{COG\_clock}}}$$

$$= \frac{1}{8\text{MHz}} = 125\text{ns}$$

Proof:

$$T_{\min} = \frac{\text{Count}}{F_{\text{COG\_clock}}}$$

$$= 125\text{ns} \cdot 10d = 1.25\mu\text{s}$$

$$T_{\max} = \frac{\text{Count} + 1}{F_{\text{COG\_clock}}}$$

$$= 125\text{ns} \cdot (10d + 1)$$

$$= 1.375\mu\text{s}$$

Therefore:

$$T_{\text{uncertainty}} = T_{\max} - T_{\min}$$

$$= 1.375\mu\text{s} - 1.25\mu\text{s}$$

$$= 125\text{ns}$$



## 11.8 Auto-shutdown Control

Auto-shutdown is a method to immediately override the COG output levels with specific overrides that allow for safe shutdown of the circuit.

The shutdown state can be either cleared automatically or held until cleared by software. In either case, the shutdown overrides remain in effect until the first rising event after the shutdown is cleared.

### 11.8.1 SHUTDOWN

The shutdown state can be entered by either of the following two mechanisms:

- Software generated
- External Input

#### 11.8.1.1 Software Generated Shutdown

Setting the GxASDE bit of the COGxASD0 register ([Register 11-7](#)) will force the COG into the shutdown state.

When auto-restart is disabled, the shutdown state will persist until the first rising event after the GxASDE bit is cleared by software.

When auto-restart is enabled, the GxASDE bit will clear automatically and resume operation on the first rising event after the shutdown input clears. See [Figure 11-8](#) and [Section 11.8.3.2 “Auto-Restart”](#).

#### 11.8.1.2 External Shutdown Source

External shutdown inputs provide the fastest way to safely suspend COG operation in the event of a Fault condition. When any of the selected shutdown inputs goes true, the output drive latches are reset and the COG outputs immediately go to the selected override levels without software delay.

Any combination of the input sources can be selected to cause a shutdown condition. Shutdown input sources include:

- HLTimer1 output
- HLTimer2 output
- C2OUT (low true)
- C1OUT (low true)
- COG1FLT pin (low true)

Shutdown inputs are selected independently with bits of the COGxASD1 register ([Register 11-8](#)).

**Note:** Shutdown inputs are level-sensitive, not edge-sensitive. The shutdown state cannot be cleared as long as the shutdown input level persists, except by disabling auto-shutdown.

### 11.8.2 PIN OVERRIDE LEVELS

The levels driven to the output pins, while the shutdown is active, are controlled by the GxASD0L<1:0> and GxASD1L<1:0> bits of the COGxASD0 register ([Register 11-7](#)). GxASD0L<1:0> controls the GxOUT0 override level and GxASD1L<1:0> controls the GxOUT1 override level. There are four override options for each output:

- Forced low
- Forced high
- Tri-state
- PWM inactive state (same state as that caused by a falling event)

**Note:** The polarity control does not apply to the forced low and high override levels.

### 11.8.3 AUTO-SHUTDOWN RESTART

After an auto-shutdown event has occurred, there are two ways to have the module resume operation:

- Software controlled
- Auto-restart

The restart method is selected with the GxARSEN bit of the COGxASD0 register. Waveforms of a software controlled automatic restart are shown in [Figure 11-8](#).

#### 11.8.3.1 Software Controlled Restart

When the GxARSEN bit of the COGxASD0 register is cleared, software must clear the GxASDE bit to restart COG operation after an auto-shutdown event.

The COG will resume operation on the first rising event after the GxASDE bit is cleared. Clearing the shutdown state requires all selected shutdown inputs to be false, otherwise, the GxASDE bit will remain set.

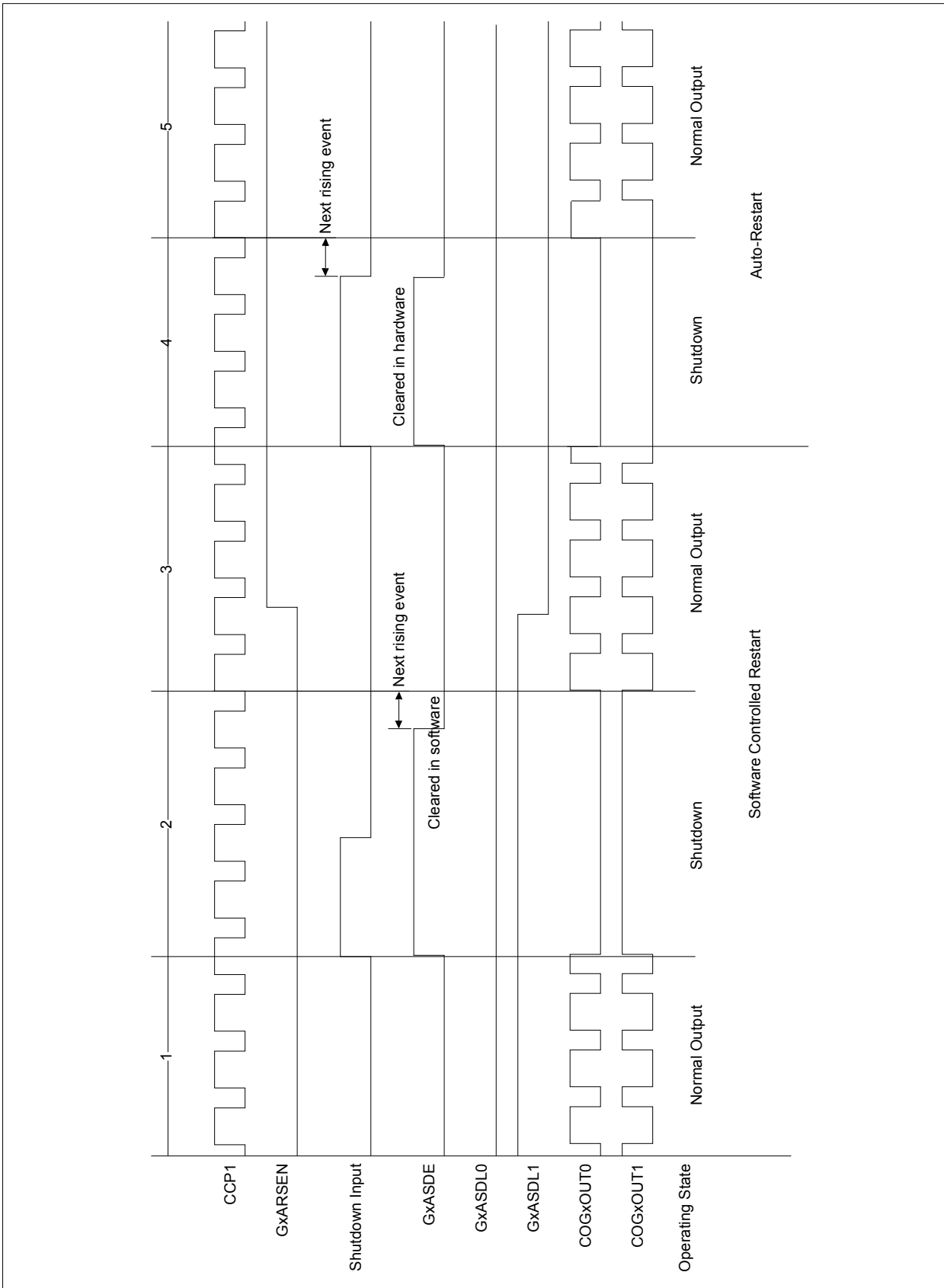
#### 11.8.3.2 Auto-Restart

When the GxARSEN bit of the COGxASD0 register is set, the COG will restart from the auto-shutdown state automatically.

The GxASDE bit will clear automatically and the COG will resume operation on the first rising event after all selected shutdown inputs go false.

# PIC16F753/HV753

**FIGURE 11-8: AUTO-SHUTDOWN WAVEFORM – CCP1 AS RISING AND FALLING EVENT INPUT SOURCE**



## 11.9 Buffer Updates

Changes to the phase, dead-band, and blanking count registers need to occur simultaneously during COG operation to avoid unintended operation that may occur as a result of delays between each register write. This is accomplished with the GxLD bit of the COGxCON0 register and double buffering of the phase, blanking, and dead-band count registers.

Before the COG module is enabled, writing the count registers loads the count buffers without need of the GxLD bit. However, when the COG is enabled, the count buffers updates are suspended after writing the count registers until after the GxLD bit is set. When the GxLD bit is set, the phase, dead-band, and blanking register values are transferred to the corresponding buffers synchronous with COG operation. The GxLD bit is cleared by hardware when the transfer is complete.

## 11.10 Alternate Pin Selection

The COGxOUT0, COGxOUT1 and COGxFLT functions can be directed to alternate pins with control bits of the APFCON register. Refer to [Register 5-1](#).

<b>Note:</b> The default COG outputs have high drive strength capability, whereas the alternate outputs do not.
---

## 11.11 Operation During Sleep

The COG continues to operate in Sleep provided that the COG\_clock, rising event, and falling event sources remain active.

The HFINTSOC remains active during Sleep when the COG is enabled and the HFINTOSC is selected as the COG\_clock source.

## 11.12 Configuring the COG

The following steps illustrate how to properly configure the COG to ensure a synchronous start with the rising event input:

1. Configure the desired COGxFLT input, COGxOUT0 and COGxOUT1 pins with the corresponding bits in the APFCON register.
2. Clear all ANSELA register bits associated with pins that are used for COG functions.
3. Ensure that the TRIS control bits corresponding to COGxOUT0 and COGxOUT1 are set so that both are configured as inputs. These will be set as outputs later.
4. Clear the GxEN bit, if not already cleared.
5. Set desired dead-band times with the COGxDBR and COGxDBF registers.
6. Set desired blanking times with the COGxBLKR and COGxBLKF registers.
7. Set desired phase delay with the COGxPHR and COGxPHF registers.
8. Select the desired shutdown sources with the COGxASD1 register.
9. Set up the following controls in COGxASD0 auto-shutdown register:
  - Select both output overrides to the desired levels (this is necessary, even if not using auto-shutdown because start-up will be from a shutdown state).
  - Set the GxASDE bit and clear the GxARSEN bit.
10. Select the desired rising and falling event sources with the COGxRIS and COGxFIS registers.
11. Select the desired rising and falling event modes with the COGxRSIM and COGxFSIM registers.
12. Configure the following controls in the COGxCON1 register:
  - Select the desired clock source
  - Select the desired dead-band timing sources
13. Configure the following controls in the COGxCON0 register:
  - Select the desired output polarities.
  - Set the output enables of the outputs to be used.
14. Set the GxEN bit.
15. Clear TRIS control bits corresponding to COGxOUT0 and COGxOUT1 to be used, thereby configuring those pins as outputs.
16. If auto-restart is to be used, set the GxARSEN bit and the GxASDE will be cleared automatically. Otherwise, clear the GxASDE bit to start the COG.

# PIC16F753/HV753

## 11.13 Register Definitions: COG Control

### REGISTER 11-1: COGxCON0: COG CONTROL REGISTER 0

R/W-0/0	R/W-0/0	R/W-0/0	R/W-0/0	R/W-0/0	R/W-0/0	U-0	R/W-0/0
GxEN	GxOE1	GxOE0	GxPOL1	GxPOL0	GxLD	—	GxMD
bit 7						bit 0	

#### Legend:

R = Readable bit	W = Writable bit	U = Unimplemented bit, read as '0'
u = Bit is unchanged	x = Bit is unknown	-n/n = Value at POR and BOR/Value at all other Resets
'1' = Bit is set	'0' = Bit is cleared	q = Value depends on condition

bit 7	<b>GxEN:</b> COGx Enable bit 1 = Module is enabled 0 = Module is disabled
bit 6	<b>GxOE1:</b> COGxOUT1 Output Enable bit 1 = COGxOUT1 is available on associated I/O pin 0 = COGxOUT1 is not available on associated I/O pin
bit 5	<b>GxOE0:</b> COGxOUT0 Output Enable bit 1 = COGxOUT0 is available on associated I/O pin 0 = COGxOUT0 is not available on associated I/O pin
bit 4	<b>GxPOL1:</b> COGxOUT1 Output Polarity bit 1 = Output is inverted polarity 0 = Output is normal polarity
bit 3	<b>GxPOL0:</b> COGxOUT0 Output Polarity bit 1 = Output is inverted polarity 0 = Output is normal polarity
bit 2	<b>GxLD:</b> COGx Load Buffers bit 1 = Phase, blanking, and dead-band buffers to be loaded with register values on next input events 0 = Register to buffer transfer is complete
bit 1	<b>Unimplemented:</b> Read as '0'
bit 0	<b>GxMD:</b> COGx Mode bit 1 = COG outputs operate in Push-Pull mode 0 = COG outputs operate in Synchronous mode

## REGISTER 11-2: COGxCON1: COG CONTROL REGISTER 1

R/W-0/0	R/W-0/0	U-0	U-0	U-0	U-0	R/W-0/0	R/W-0/0
GxRDBTS	GxFDBTS	—	—	—	—	GxCS<1:0>	
bit 7						bit 0	

### Legend:

R = Readable bit	W = Writable bit	U = Unimplemented bit, read as '0'
u = Bit is unchanged	x = Bit is unknown	-n/n = Value at POR and BOR/Value at all other Resets
'1' = Bit is set	'0' = Bit is cleared	q = Value depends on condition

- bit 7      **GxRDBTS:** COGx Rising Event Dead-band Timing Source Select bit  
 1 = Delay chain and COGxDBR are used for dead-band timing generation  
 0 = COGx\_clk and COGxDBR are used for dead-band timing generation
- bit 6      **GxFDBTS:** COGx Falling Event Dead-band Timing Source Select bit  
 1 = Delay chain and COGxDF are used for dead-band timing generation  
 0 = COGx\_clk and COGxDBF are used for dead-band timing generation
- bit 5-2    **Unimplemented:** Read as '0'
- bit 1-0    **GxCS<1:0>:** COGx Clock Source Select bits  
 11 = Reserved  
 10 = HFINTOSC (stays active during Sleep)  
 01 = Fosc/4  
 00 = Fosc

# PIC16F753/HV753

## REGISTER 11-3: COGxRIS: COG RISING EVENT INPUT SELECTION REGISTER

U-0	R/W-0/0	R/W-0/0	R/W-0/0	R/W-0/0	R/W-0/0	R/W-0/0	R/W-0/0
—	GxRIHLT2	GxRIHLT1	GxRIT2M	GxRIFLT	GxRICCP1	GxRIC2	GxRIC1
bit 7							bit 0

### Legend:

R = Readable bit	W = Writable bit	U = Unimplemented bit, read as '0'
u = Bit is unchanged	x = Bit is unknown	-n/n = Value at POR and BOR/Value at all other Resets
'1' = Bit is set	'0' = Bit is cleared	q = Value depends on condition

- bit 7      **Unimplemented:** Read as '0'
- bit 6      **GxRIHLT2:** COGx Rising Event Input Source 6 Enable bit  
 1 = HLTimer2 output is enabled as a rising event input  
 0 = HLTimer2 has no effect on the rising event
- bit 5      **GxRIHLT1:** COGx Rising Event Input Source 5 Enable bit  
 1 = HLTimer1 output is enabled as a rising event input  
 0 = HLTimer1 has no effect on the rising event
- bit 4      **GxRIT2M:** COGx Rising Event Input Source 4 Enable bit  
 1 = Timer2 match with PR2 is enabled as a rising event input  
 0 = Timer2 match with PR2 has no effect on the rising event
- bit 3      **GxRIFLT:** COGx Rising Event Input Source 3 Enable bit  
 1 = COGxFLT pin is enabled as a rising event input  
 0 = COGxFLT pin has no effect on the rising event
- bit 2      **GxRICCP1:** COGx Rising Event Input Source 2 Enable bit  
 1 = CCP1 output is enabled as a rising event input  
 0 = CCP1 has no effect on the rising event
- bit 1      **GxRIC2:** COGx Rising Event Input Source 1 Enable bit  
 1 = Comparator 2 output is enabled as a rising event input  
 0 = Comparator 2 output has no effect on the rising event
- bit 0      **GxRIC1:** COGx Rising Event Input Source 0 Enable bit  
 1 = Comparator 1 output is enabled as a rising event input  
 0 = Comparator 1 output has no effect on the rising event

## REGISTER 11-4: COGxRSIM: COG RISING EVENT SOURCE INPUT MODE REGISTER

U-0	R/W-0/0	R/W-0/0	R/W-0/0	R/W-0/0	R/W-0/0	R/W-0/0	R/W-0/0
—	GxRMHLT2	GxRMHLT1	GxRMT2M	GxRMFLT	GxRMCCP1	GxRMC2	GxRMC1
bit 7							bit 0

### Legend:

R = Readable bit	W = Writable bit	U = Unimplemented bit, read as '0'
u = Bit is unchanged	x = Bit is unknown	-n/n = Value at POR and BOR/Value at all other Resets
'1' = Bit is set	'0' = Bit is cleared	q = Value depends on condition

bit 7 **Unimplemented:** Read as '0'

bit 6 **GxRMHLT2:** COGx Rising Event Input Source 6 Mode bit<sup>(1)</sup>

GxRIHLT2 = 1:

1 = HLTimer2 low-to-high transition will cause a rising event after rising event phase delay

0 = HLTimer2 high level will cause an immediate rising event

GxRIHLT2 = 0:

HLTimer2 has no effect on rising event

bit 5 **GxRMHLT1:** COGx Rising Event Input Source 5 Mode bit<sup>(1)</sup>

GxRIHLT1 = 1:

1 = HLTimer1 low-to-high transition will cause a rising event after rising event phase delay

0 = HLTimer1 high level will cause an immediate rising event

GxRIHLT1 = 0:

HLTimer1 has no effect on rising event

bit 4 **GxRMT2M:** COGx Rising Event Input Source 4 Mode bit<sup>(1)</sup>

GxRIT2M = 1:

1 = Timer2 match with PR2 low-to-high transition will cause a rising event after rising event phase delay

0 = Timer2 match with PR2 high level will cause an immediate rising event

GxRIT2M = 0:

Timer2 match with PR2 has no effect on rising event

bit 3 **GxRMFLT:** COGx Rising Event Input Source 3 Mode bit

GxRIFLT = 1:

1 = COGxFLT pin low-to-high transition will cause a rising event after rising event phase delay

0 = COGxFLT pin high level will cause an immediate rising event

GxRIFLT = 0:

COGxFLT pin has no effect on rising event

bit 2 **GxRMCCP1:** COGx Rising Event Input Source 2 Mode bit

GxRICCP1 = 1:

1 = CCP1 low-to-high transition will cause a rising event after rising event phase delay

0 = CCP1 high level will cause an immediate rising event

GxRICCP1 = 0:

CCP1 has no effect on rising event

bit 1 **GxRMC2:** COGx Rising Event Input Source 1 Mode bit

GxRIC2 = 1:

1 = Comparator 2 low-to-high transition will cause a rising event after rising event phase delay

0 = Comparator 2 high level will cause an immediate rising event

GxRIC2 = 0:

Comparator 2 has no effect on rising event

bit 0 **GxRMC1:** COGx Rising Event Input Source 0 Mode bit

GxRIC1 = 1:

1 = Comparator 1 low-to-high transition will cause a rising event after rising event phase delay

0 = Comparator 1 high level will cause an immediate rising event

GxRIC1 = 0:

Comparator 1 has no effect on rising event

**Note 1:** These sources are pulses and therefore the only benefit of Edge mode over Level mode is that they can be delayed by rising event phase delay.

# PIC16F753/HV753

## REGISTER 11-5: COGxFIS: COG FALLING EVENT INPUT SELECTION REGISTER

U-0	R/W-0/0	R/W-0/0	R/W-0/0	R/W-0/0	R/W-0/0	R/W-0/0	R/W-0/0
—	GxFIHLT2	GxFIHLT1	GxFIT2M	GxFIFLT	GxFICCP1	GxFIC2	GxFIC1
bit 7							bit 0

### Legend:

R = Readable bit	W = Writable bit	U = Unimplemented bit, read as '0'
u = Bit is unchanged	x = Bit is unknown	-n/n = Value at POR and BOR/Value at all other Resets
'1' = Bit is set	'0' = Bit is cleared	q = Value depends on condition

- bit 7      **Unimplemented:** Read as '0'
- bit 6      **GxFIHLT2:** COGx Falling Event Input Source 6 Enable bit  
 1 = HLTimer2 output is enabled as a falling event input  
 0 = HLTimer2 has no effect on the falling event
- bit 5      **GxFIHLT1:** COGx Falling Event Input Source 5 Enable bit  
 1 = HLTimer1 output is enabled as a falling event input  
 0 = HLTimer1 has no effect on the falling event
- bit 4      **GxFIT2M:** COGx Falling Event Input Source 4 Enable bit  
 1 = Timer2 match with PR2 is enabled as a falling event input  
 0 = Timer2 match with PR2 has no effect on the falling event
- bit 3      **GxFIFLT:** COGx Falling Event Input Source 3 Enable bit  
 1 = COGxFLT pin is enabled as a falling event input  
 0 = COGxFLT pin has no effect on the falling event
- bit 2      **GxFICCP1:** COGx Falling Event Input Source 2 Enable bit  
 1 = CCP1 output is enabled as a falling event input  
 0 = CCP1 has no effect on the falling event
- bit 1      **GxFIC2:** COGx Falling Event Input Source 1 Enable bit  
 1 = Comparator 2 output is enabled as a falling event input  
 0 = Comparator 2 output has no effect on the falling event
- bit 0      **GxFIC1:** COGx Falling Event Input Source 0 Enable bit  
 1 = Comparator 1 output is enabled as a falling event input  
 0 = Comparator 1 output has no effect on the falling event



## REGISTER 11-6: COGxFSIM: COG FALLING EVENT SOURCE INPUT MODE REGISTER

U-0	R/W-0/0	R/W-0/0	R/W-0/0	R/W-0/0	R/W-0/0	R/W-0/0	R/W-0/0
—	GxFMHLT2	GxFMHLT1	GxFMT2M	GxFMFLT	GxFMCCP1	GxFMC2	GxFMC1
bit 7							bit 0

### Legend:

R = Readable bit	W = Writable bit	U = Unimplemented bit, read as '0'
u = Bit is unchanged	x = Bit is unknown	-n/n = Value at POR and BOR/Value at all other Resets
'1' = Bit is set	'0' = Bit is cleared	q = Value depends on condition

bit 7 **Unimplemented:** Read as '0'

bit 6 **GxFMHLT2:** COGx Falling Event Input Source 6 Mode bit<sup>(1)</sup>

GxFIHLT2 = 1:

1 = HLTimer2 low-to-high transition will cause a falling event after falling event phase delay

0 = HLTimer2 high level will cause an immediate falling event

GxFIHLT2 = 0:

HLTimer2 has no effect on falling event

bit 5 **GxFMHLT1:** COGx Falling Event Input Source 5 Mode bit<sup>(1)</sup>

GxFIHLT1 = 1:

1 = HLTimer1 low-to-high transition will cause a falling event after falling event phase delay

0 = HLTimer1 high level will cause an immediate falling event

GxFIHLT1 = 0:

HLTimer1 has no effect on falling event

bit 4 **GxFMT2M:** COGx Falling Event Input Source 4 Mode bit<sup>(1)</sup>

GxFIT2M = 1:

1 = Timer2 match with PR2 low-to-high transition will cause a falling event after falling event phase delay

0 = Timer2 match with PR2 high level will cause an immediate falling event

GxFIT2M = 0:

Timer2 match with PR2 has no effect on falling event

bit 3 **GxFMFLT:** COGx Falling Event Input Source 3 Mode bit

GxFIFLT = 1:

1 = COGxFLT pin low-to-high transition will cause a falling event after falling event phase delay

0 = COGxFLT pin high level will cause an immediate falling event

GxFIFLT = 0:

COGxFLT pin has no effect on falling event

bit 2 **GxFMCCP1:** COGx Falling Event Input Source 2 Mode bit

GxFICCP1 = 1:

1 = CCP1 low-to-high transition will cause a falling event after falling event phase delay

0 = CCP1 high level will cause an immediate falling event

GxFICCP1 = 0:

CCP1 has no effect on falling event

bit 1 **GxFMC2:** COGx Falling Event Input Source 1 Mode bit

GxFIC2 = 1:

1 = Comparator 2 low-to-high transition will cause a falling event after falling event phase delay

0 = Comparator 2 high level will cause an immediate falling event

GxFIC2 = 0:

Comparator 2 has no effect on falling event

bit 0 **GxFMC1:** COGx Falling Event Input Source 0 Mode bit

GxFIC1 = 1:

1 = Comparator 1 low-to-high transition will cause a falling event after falling event phase delay

0 = Comparator 1 high level will cause an immediate falling event

GxFIC1 = 0:

Comparator 1 has no effect on falling event

**Note 1:** These sources are pulses and therefore the only benefit of Edge mode over Level mode is that they can be delayed by falling event phase delay.

# PIC16F753/HV753

## REGISTER 11-7: COGxASD0: COG AUTO-SHUTDOWN CONTROL REGISTER 0

R/W-0/0	R/W-0/0	R/W-0/0	R/W-0/0	R/W-0/0	R/W-0/0	U-0	U-0
GxASDE	GxARSEN	GxASD1L<1:0>		GxASD0L<1:0>		—	—
bit 7						bit 0	

### Legend:

R = Readable bit	W = Writable bit	U = Unimplemented bit, read as '0'
u = Bit is unchanged	x = Bit is unknown	-n/n = Value at POR and BOR/Value at all other Resets
'1' = Bit is set	'0' = Bit is cleared	q = Value depends on condition

- bit 7      **GxASDE:** Auto-Shutdown Event Status bit  
 1 = COG is in the shutdown state  
 0 = COG is either not in the shutdown state or will exit the shutdown state on the next rising event
- bit 6      **GxARSEN:** Auto-Restart Enable bit  
 1 = Auto-restart is enabled  
 0 = Auto-restart is disabled
- bit 5-4    **GxASD1L<1:0>:** COGxOUT1 Auto-Shutdown Override Level Select bits  
 11 = COGxOUT1 is tri-stated when shutdown is active  
 10 = The inactive state of the pin, including polarity, is placed on COGxOUT1 when shutdown is active  
 01 = A logic '1' is placed on COGxOUT1 when shutdown is active  
 00 = A logic '0' is placed on COGxOUT1 when shutdown is active
- bit 3-2    **GxASD0L<1:0>:** COGxOUT0 Auto-Shutdown Override Level Select bits  
 11 = COGxOUT0 is tri-stated when shutdown is active  
 10 = The inactive state of the pin, including polarity, is placed on COGxOUT0 when shutdown is active  
 01 = A logic '1' is placed on COGxOUT0when shutdown is active  
 00 = A logic '0' is placed on COGxOUT0when shutdown is active
- bit 1-0    **Unimplemented:** Read as '0'

## REGISTER 11-8: COGxASD1: COG AUTO-SHUTDOWN CONTROL REGISTER 1

U-0	U-0	U-0	R/W-0/0	R/W-0/0	R/W-0/0	R/W-0/0	R/W-0/0
—	—	—	GxASDSHLT2	GxASDSHLT1	GxASDSC2	GxASDSC1	GxASDSFLT
bit 7							bit 0

### Legend:

R = Readable bit	W = Writable bit	U = Unimplemented bit, read as '0'
u = Bit is unchanged	x = Bit is unknown	-n/n = Value at POR and BOR/Value at all other Resets
'1' = Bit is set	'0' = Bit is cleared	q = Value depends on condition

- bit 7-5     **Unimplemented:** Read as '0'
- bit 4     **GxASDSHLT2:** COGx Auto-Shutdown Source Enable bit 4  
           1 = COGx is shutdown when HLTMR2 equals HLTMR2  
           0 = HLTMR2 has no effect on shutdown
- bit 3     **GxASDSHLT1:** COGx Auto-Shutdown Source Enable bit 3  
           1 = COGx is shutdown when HLTMR1 equals HLTMR1  
           0 = HLTMR1 has no effect on shutdown
- bit 2     **GxASDSC2:** COGx Auto-Shutdown Source Enable bit 2  
           1 = COGx is shutdown when Comparator 2 output is low  
           0 = Comparator 2 output has no effect on shutdown
- bit 1     **GxASDSC1:** COGx Auto-Shutdown Source Enable bit 1  
           1 = COGx is shutdown when Comparator 1 output is low  
           0 = Comparator 1 output has no effect on shutdown
- bit 0     **GxASDSFLT:** COGx Auto-Shutdown Source Enable bit 0  
           1 = COGx is shutdown when COGxFLT pin is low  
           0 = COGxFLT pin has no effect on shutdown

# PIC16F753/HV753

## REGISTER 11-9: COG<sub>x</sub>DBR: COG RISING EVENT DEAD-BAND COUNT REGISTER

U-0	U-0	U-0	U-0	R/W-x/u	R/W-x/u	R/W-x/u	R/W-x/u
—	—	—	—	GxDBR<3:0>			
bit 7				bit 0			

### Legend:

R = Readable bit	W = Writable bit	U = Unimplemented bit, read as '0'
u = Bit is unchanged	x = Bit is unknown	-n/n = Value at POR and BOR/Value at all other Resets
'1' = Bit is set	'0' = Bit is cleared	q = Value depends on condition

bit 7-4      **Unimplemented:** Read as '0'

bit 3-0      **GxDBR<3:0>:** Rising Event Dead-band Count Value bits

GxRDBTS = 1:

= Number of delay chain element periods to delay primary output after rising event

GxRDBTS = 0:

= Number of COG<sub>x</sub> clock periods to delay primary output after rising event

## REGISTER 11-10: COG<sub>x</sub>DBF: COG FALLING EVENT DEAD-BAND COUNT REGISTER

U-0	U-0	U-0	U-0	R/W-x/u	R/W-x/u	R/W-x/u	R/W-x/u
—	—	—	—	GxDBF<3:0>			
bit 7				bit 0			

### Legend:

R = Readable bit	W = Writable bit	U = Unimplemented bit, read as '0'
u = Bit is unchanged	x = Bit is unknown	-n/n = Value at POR and BOR/Value at all other Resets
'1' = Bit is set	'0' = Bit is cleared	q = Value depends on condition

bit 7-4      **Unimplemented:** Read as '0'

bit 3-0      **GxDBF<3:0>:** Falling Event Dead-Band Count Value bits

GxFDBTS = 1:

= Number of delay chain element periods to delay complementary output after falling event input

GxFDBTS = 0:

= Number of COG<sub>x</sub> clock periods to delay complementary output after falling event input

## REGISTER 11-11: COGxBLKR: COG RISING EVENT BLANKING COUNT REGISTER

U-0	U-0	U-0	U-0	R/W-x/u	R/W-x/u	R/W-x/u	R/W-x/u
—	—	—	—	GxBLKR<3:0>			
bit 7							bit 0

**Legend:**

R = Readable bit	W = Writable bit	U = Unimplemented bit, read as '0'
u = Bit is unchanged	x = Bit is unknown	-n/n = Value at POR and BOR/Value at all other Resets
'1' = Bit is set	'0' = Bit is cleared	q = Value depends on condition

bit 7-4      **Unimplemented:** Read as '0'  
bit 3-0      **GxBLKR<3:0>:** Rising Event Blanking Count Value bits  
= Number of COGx clock periods to inhibit falling event inputs

## REGISTER 11-12: COGxBLKF: COG FALLING EVENT BLANKING COUNT REGISTER

U-0	U-0	U-0	U-0	R/W-x/u	R/W-x/u	R/W-x/u	R/W-x/u
—	—	—	—	GxBLKF<3:0>			
bit 7							bit 0

**Legend:**

R = Readable bit	W = Writable bit	U = Unimplemented bit, read as '0'
u = Bit is unchanged	x = Bit is unknown	-n/n = Value at POR and BOR/Value at all other Resets
'1' = Bit is set	'0' = Bit is cleared	q = Value depends on condition

bit 7-4      **Unimplemented:** Read as '0'  
bit 3-0      **GxBLKF<3:0>:** Falling Event Blanking Count Value bits  
= Number of COGx clock periods to inhibit rising event inputs

# PIC16F753/HV753

## REGISTER 11-13: COGxPHR: COG RISING EDGE PHASE DELAY COUNT REGISTER

U-0	U-0	U-0	U-0	R/W-x/u	R/W-x/u	R/W-x/u	R/W-x/u
—	—	—	—	GxPHR<3:0>			
bit 7				bit 0			

**Legend:**

R = Readable bit	W = Writable bit	U = Unimplemented bit, read as '0'
u = Bit is unchanged	x = Bit is unknown	-n/n = Value at POR and BOR/Value at all other Resets
'1' = Bit is set	'0' = Bit is cleared	q = Value depends on condition

bit 7-4      **Unimplemented:** Read as '0'

bit 3-0      **GxPHR<3:0>:** Rising Edge Phase Delay Count Value bits  
 = Number of COGx clock periods to delay rising edge event

## REGISTER 11-14: COGxPHF: COG FALLING EDGE PHASE DELAY COUNT REGISTER

U-0	U-0	U-0	U-0	R/W-x/u	R/W-x/u	R/W-x/u	R/W-x/u
—	—	—	—	GxPHF<3:0>			
bit 7				bit 0			

**Legend:**

R = Readable bit	W = Writable bit	U = Unimplemented bit, read as '0'
u = Bit is unchanged	x = Bit is unknown	-n/n = Value at POR and BOR/Value at all other Resets
'1' = Bit is set	'0' = Bit is cleared	q = Value depends on condition

bit 7-4      **Unimplemented:** Read as '0'

bit 3-0      **GxPHF<3:0>:** Falling Edge Phase Delay Count Value bits  
 = Number of COGx clock periods to delay falling edge event

**TABLE 11-1: SUMMARY OF REGISTERS ASSOCIATED WITH COG**

Name	Bit 7	Bit 6	Bit 5	Bit 4	Bit 3	Bit 2	Bit 1	Bit 0	Register on Page
ANSELA	—	—	—	ANSA4	—	ANSA2	ANSA1	ANSA0	48
APFCON	—	—	—	T1GSEL	—	—	—	—	44
COG1PHR	—	—	—	—	G1PHR<3:0>				110
COG1PHF	—	—	—	—	G1PHF<3:0>				110
COG1BKR	—	—	—	—	G1BLKR<3:0>				109
COG1BKF	—	—	—	—	G1BLKF<3:0>				109
COG1DBR	—	—	—	—	G1DBR<3:0>				108
COG1DBF	—	—	—	—	G1DBF<3:0>				108
COG1RIS	—	G1RIHLT2	G1RIHLT1	G1RIT2M	G1RIFLT	G1RICCP1	G1RIC2	G1RIC1	102
COG1RSIM	—	G1RMHLT2	G1RMHLT1	G1RMT2M	G1RMFLT	G1RMCCP1	G1RMC2	G1RMC1	103
COG1FIS	—	G1FIHLT2	G1FIHLT1	G1FIT2M	G1FIFLT	G1FICCP1	G1FIC2	G1FIC1	104
COG1FSIM	—	G1FMHLT2	G1FMHLT1	G1FMT2M	G1FMFLT	G1FMCCP1	G1FMC2	G1FMC1	105
COG1CON0	G1EN	G1OE1	G1OE0	G1POL1	G1POL0	G1LD	—	G1MD	100
COG1CON1	G1RDBTS	G1FDBTS	—	—	—	—	G1CS<1:0>		101
COG1ASD0	G1ASDE	G1ARSEN	G1ASD1L<1:0>		G1ASD0L<1:0>		—	—	106
COG1ASD1	—	—	—	G1ASD1SHLT2	G1ASD1SHLT1	G1ASD1SC2	G1ASD1SC1	G1ASD1SFLT	107
INTCON	GIE	PEIE	TOIE	INTE	IOCIE	TOIF	INTF	IOCIF	19
LATA	—	—	LATA5	LATA4	—	LATA2	LATA1	LATA0	46
PIE2	—	—	C2IE	C1IE	—	COG1IE	—	CCP1IE	21
PIR2	—	—	C2IF	C1IF	—	COG1IF	—	CCP1IF	23
TRISA	—	—	TRISA5	TRISA4	TRISA3	TRISA2	TRISA1	TRISA0	46

**Legend:** x = unknown, u = unchanged, — = unimplemented locations read as '0'. Shaded cells are not used by COG.

# PIC16F753/HV753

---

NOTES:



## 12.0 ANALOG-TO-DIGITAL CONVERTER (ADC) MODULE

The Analog-to-Digital Converter (ADC) allows conversion of an analog input signal to a 10-bit binary representation of that signal. This device uses analog inputs, which are multiplexed into a single sample and hold circuit. The output of the sample and hold is connected to the input of the converter. The converter generates a 10-bit binary result via successive approximation and stores the conversion result into the ADC result registers (ADRESL and ADRESH).

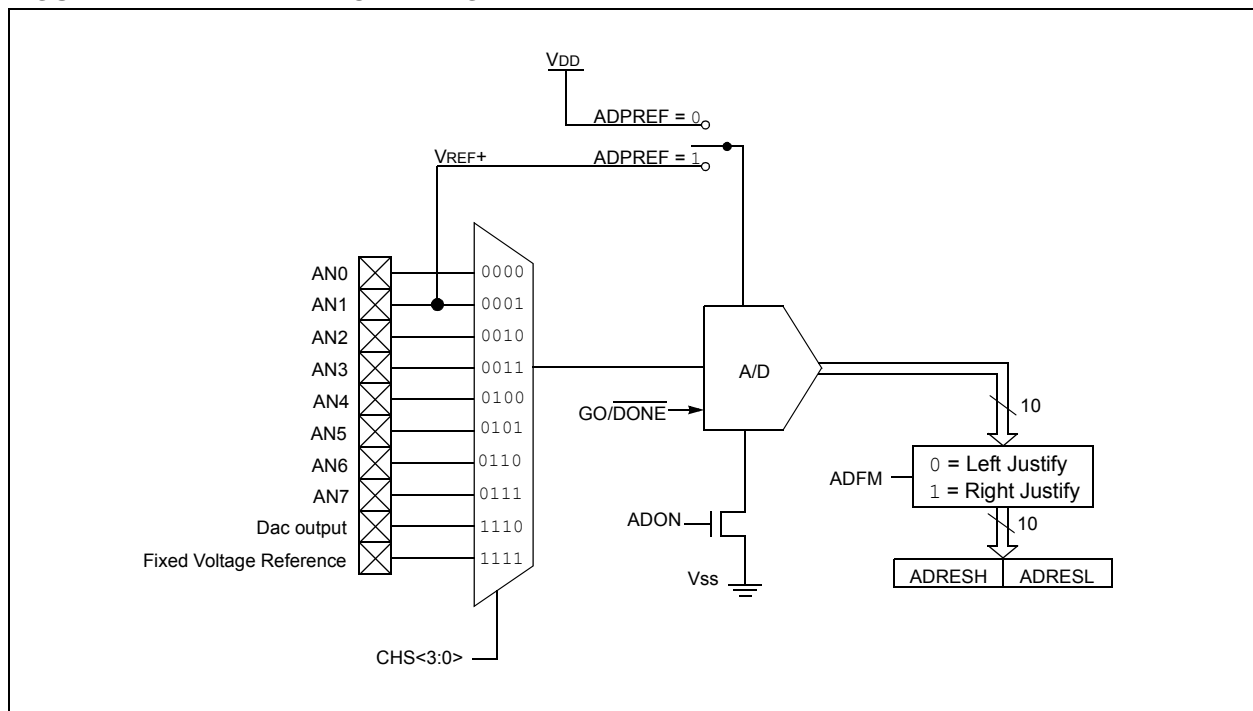
**Note:** The ADRESL and ADRESH registers are read-only.

The ADC voltage reference is software selectable to either VDD or a voltage applied to the external reference pins.

The ADC can generate an interrupt upon completion of a conversion. This interrupt can be used to wake-up the device from Sleep.

Figure 12-1 shows the block diagram of the ADC.

**FIGURE 12-1: ADC BLOCK DIAGRAM**



# PIC16F753/HV753

---

## 12.1 ADC Configuration

When configuring and using the ADC the following functions must be considered:

- Port configuration
- Channel selection
- ADC voltage reference selection
- ADC conversion clock source
- Interrupt control
- Results formatting

### 12.1.1 PORT CONFIGURATION

The ADC can be used to convert both analog and digital signals. When converting analog signals, the I/O pin should be configured for analog by setting the associated TRIS and ANSEL bits. See the corresponding port section for more information.

**Note:** Analog voltages on any pin that is defined as a digital input may cause the input buffer to conduct excess current.

### 12.1.2 CHANNEL SELECTION

The CHS bits of the ADCON0 register determine which channel is connected to the sample and hold circuit.

When changing channels, a delay is required before starting the next conversion. Refer to [Section 12.2 “ADC Operation”](#) for more information.

### 12.1.3 ADC VOLTAGE REFERENCE

The ADPREF1 bit of the ADCON1 register provides control of the positive voltage reference. The positive voltage reference can be either V<sub>DD</sub> or an external voltage source. The negative voltage reference is always connected to the ground reference.

### 12.1.4 CONVERSION CLOCK

The source of the conversion clock is software selectable via the ADCS bits of the ADCON1 register. There are seven possible clock options:

- Fosc/2
- Fosc/4
- Fosc/8
- Fosc/16
- Fosc/32
- Fosc/64
- FRC (dedicated internal oscillator)

The time to complete one bit conversion is defined as T<sub>AD</sub>. One full 10-bit conversion requires 11 T<sub>AD</sub> periods as shown in [Figure 12-2](#).

For correct conversion, the appropriate T<sub>AD</sub> specification must be met. See A/D conversion requirements in [Section 22.0 “Electrical Specifications”](#) for more information. [Table 12-1](#) gives examples of appropriate ADC clock selections.

**Note:** Unless using the FRC, any changes in the system clock frequency will change the ADC clock frequency, which may adversely affect the ADC result.

**TABLE 12-1: ADC CLOCK PERIOD (TAD) VS. DEVICE OPERATING FREQUENCIES (VDD ≥ 3.0V)**

ADC Clock Period (TAD)		Device Frequency (Fosc)			
ADC Clock Source	ADCS<2:0>	20 MHz	8 MHz	4 MHz	1 MHz
Fosc/2	000	100 ns <sup>(2)</sup>	250 ns <sup>(2)</sup>	500 ns <sup>(2)</sup>	2.0 μs
Fosc/4	100	200 ns <sup>(2)</sup>	500 ns <sup>(2)</sup>	1.0 μs <sup>(2)</sup>	4.0 μs
Fosc/8	001	400 ns <sup>(2)</sup>	1.0 μs <sup>(2)</sup>	2.0 μs	8.0 μs <sup>(3)</sup>
Fosc/16	101	800 ns <sup>(2)</sup>	2.0 μs	4.0 μs	16.0 μs <sup>(3)</sup>
Fosc/32	010	1.6 μs	4.0 μs	8.0 μs <sup>(3)</sup>	32.0 μs <sup>(3)</sup>
Fosc/64	110	3.2 μs	8.0 μs <sup>(3)</sup>	16.0 μs <sup>(3)</sup>	64.0 μs <sup>(3)</sup>
FRC	x11	2-6 μs <sup>(1,4)</sup>	2-6 μs <sup>(1,4)</sup>	2-6 μs <sup>(1,4)</sup>	2-6 μs <sup>(1,4)</sup>

**Legend:** Shaded cells are outside of recommended range.

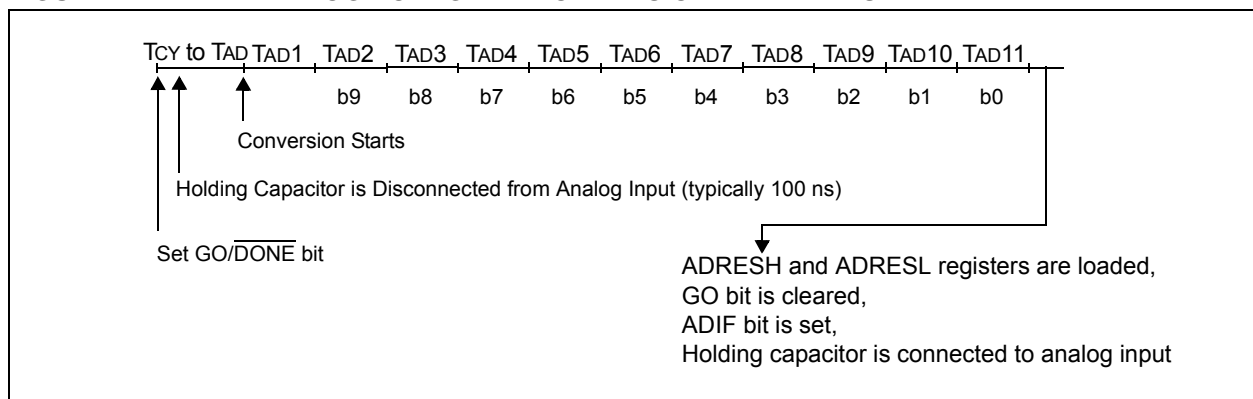
**Note 1:** The FRC source has a typical TAD time of 4 μs for VDD > 3.0V.

**2:** These values violate the minimum required TAD time.

**3:** For faster conversion times, the selection of another clock source is recommended.

**4:** When the device frequency is greater than 1 MHz, the FRC clock source is only recommended if the conversion will be performed during Sleep.

**FIGURE 12-2: ANALOG-TO-DIGITAL CONVERSION TAD CYCLES**



## 12.1.5 INTERRUPTS

The ADC module allows for the ability to generate an interrupt upon completion of an Analog-to-Digital conversion. The ADC interrupt flag is the ADIF bit in the PIR1 register. The ADC interrupt enable is the ADIE bit in the PIE1 register. The ADIF bit must be cleared in software.

**Note:** The ADIF bit is set at the completion of every conversion, regardless of whether or not the ADC interrupt is enabled.

This interrupt can be generated while the device is operating or while in Sleep. If the device is in Sleep, the interrupt will wake-up the device. Upon waking from Sleep, the next instruction following the SLEEP instruction is always executed. If the user is attempting to wake-up from Sleep and resume in-line code execution, the global interrupt must be disabled. If the global interrupt is enabled, execution will switch to the Interrupt Service Routine.

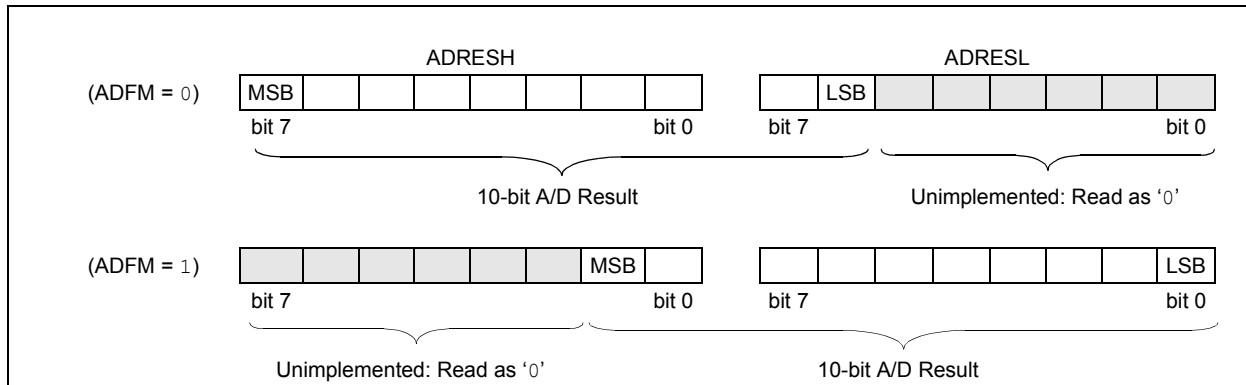
# PIC16F753/HV753

## 12.1.6 RESULT FORMATTING

The 10-bit A/D conversion result can be supplied in two formats, left justified or right justified. The ADFM bit of the ADCON0 register controls the output format.

Figure 12-4 shows the two output formats.

**FIGURE 12-3: 10-BIT A/D CONVERSION RESULT FORMAT**



## 12.2 ADC Operation

### 12.2.1 STARTING A CONVERSION

To enable the ADC module, the ADON bit of the ADCON0 register must be set to a '1'. Setting the GO/DONE bit of the ADCON0 register to a '1' will start the Analog-to-Digital conversion.

**Note:** The GO/DONE bit should not be set in the same instruction that turns on the ADC. Refer to [Section 12.2.6 "A/D Conversion Procedure"](#).

### 12.2.2 COMPLETION OF A CONVERSION

When the conversion is complete, the ADC module will:

- Clear the GO/DONE bit
- Set the ADIF flag bit
- Update the ADRESH:ADRESL registers with new conversion result

### 12.2.3 TERMINATING A CONVERSION

If a conversion must be terminated before completion, the GO/DONE bit can be cleared in software. The ADRESH:ADRESL registers will not be updated with the partially complete Analog-to-Digital conversion sample. Instead, the ADRESH:ADRESL register pair will retain the value of the previous conversion. Additionally, a 2 TAD delay is required before another acquisition can be initiated. Following this delay, an input acquisition is automatically started on the selected channel.

**Note:** A device Reset forces all registers to their Reset state. Thus, the ADC module is turned off and any pending conversion is terminated.

### 12.2.4 ADC OPERATION DURING SLEEP

The ADC module can operate during Sleep. This requires the ADC clock source to be set to the FRC option. When the FRC clock source is selected, the ADC waits one additional instruction before starting the conversion. This allows the SLEEP instruction to be executed, which can reduce system noise during the conversion. If the ADC interrupt is enabled, the device will wake-up from Sleep when the conversion completes. If the ADC interrupt is disabled, the ADC module is turned off after the conversion completes, although the ADON bit remains set.

When the ADC clock source is something other than FRC, a SLEEP instruction causes the present conversion to be aborted and the ADC module is turned off, although the ADON bit remains set.

### 12.2.5 SPECIAL EVENT TRIGGER

The CCP Special Event Trigger allows periodic ADC measurements without software intervention. When this trigger occurs, the GO/DONE bit is set by hardware and the Timer1 counter resets to zero.

Using the Special Event Trigger does not assure proper ADC timing. It is the user's responsibility to ensure that the ADC timing requirements are met.

See [Section 10.0 "Capture/Compare/PWM Modules"](#) for more information.

## 12.2.6 A/D CONVERSION PROCEDURE

This is an example procedure for using the ADC to perform an Analog-to-Digital conversion:

1. Configure Port:
  - Disable pin output driver (See TRIS register)
  - Configure pin as analog
2. Configure the ADC module:
  - Select ADC conversion clock
  - Configure voltage reference
  - Select ADC input channel
  - Select result format
  - Turn on ADC module
3. Configure ADC interrupt (optional):
  - Clear ADC interrupt flag
  - Enable ADC interrupt
  - Enable peripheral interrupt
  - Enable global interrupt<sup>(1)</sup>
4. Wait the required acquisition time<sup>(2)</sup>.
5. Start conversion by setting the GO/DONE bit.
6. Wait for ADC conversion to complete by one of the following:
  - Polling the GO/DONE bit
  - Waiting for the ADC interrupt (interrupts enabled)
7. Read ADC Result
8. Clear the ADC interrupt flag (required if interrupt is enabled).

## EXAMPLE 12-1: A/D CONVERSION

```

;This code block configures the ADC
;for polling, Vdd reference, Frc clock
;and RA0 input.
;
;Conversion start & polling for completion
;are included.
;
BANKSEL TRISA      ;
BSF      TRISA,0   ;Set RA0 to input
BANKSEL ADCON1    ;
MOVLW   B'01110000' ;ADC Frc clock,
IORWF   ADCON1    ; and RA0 as analog
BANKSEL ADCON0    ;
MOVLW   B'10000001' ;Right justify,
MOVWF   ADCON0    ;Vdd Vref, AN0, On
CALL    SampleTime ;Acquisiton delay
BSF     ADCON0,GO  ;Start conversion
TEST AGAIN
BTFSC   ADCON0,GO  ;Is conversion done?
GOTO    TEST AGAIN ;No, test again
BANKSEL ADRESH    ;
MOVF    ADRESH,W  ;Read upper 2 bits
MOVWF   RESULTHI  ;Store in GPR space
BANKSEL ADRESL    ;
MOVF    ADRESL,W  ;Read lower 8 bits
MOVWF   RESULTLO  ;Store in GPR space
    
```

**Note 1:** The global interrupt can be disabled if the user is attempting to wake-up from Sleep and resume in-line code execution.

**2:** See [Section 12.4 “A/D Acquisition Requirements”](#).

# PIC16F753/HV753

## 12.3 Register Definitions: ADC Control

### REGISTER 12-1: ADCON0: A/D CONTROL REGISTER 0

R/W-0	U-0	R/W-0	R/W-0	R/W-0	R/W-0	R/W-0	R/W-0
ADFM	—	CHS<3:0>				GO/DONE	ADON
bit 7							bit 0

**Legend:**

R = Readable bit

W = Writable bit

U = Unimplemented bit, read as '0'

-n = Value at POR

'1' = Bit is set

'0' = Bit is cleared

x = Bit is unknown

bit 7      **ADFM:** A/D Conversion Result Format Select bit

1 = Right justified

0 = Left justified

bit 6      **Unimplemented:** Read as '0'

bit 5-2    **CHS<3:0>:** Analog Channel Select bits

0000 = AN0

0001 = AN1

0010 = AN2

0011 = AN3

0100 = AN4

0101 = AN5

0110 = AN6

0111 = AN7

1110 = DAC output

1111 = Fixed Voltage Reference

bit 1      **GO/DONE:** A/D Conversion Status bit

1 = A/D conversion cycle in progress. Setting this bit starts an A/D conversion cycle.

This bit is automatically cleared by hardware when the A/D conversion has completed.

0 = A/D conversion completed/not in progress

bit 0      **ADON:** ADC Enable bit

1 = ADC is enabled

0 = ADC is disabled and consumes no operating current

## REGISTER 12-2: ADCON1: A/D CONTROL REGISTER 1

U-0	R/W-0/0	R/W-0/0	R/W-0/0	U-0	U-0	U-0	R/W-0/0
—	ADCS<2:0>			—	—	—	ADPREF1
bit 7							bit 0

### Legend:

R = Readable bit	W = Writable bit	U = Unimplemented bit, read as '0'
u = Bit is unchanged	x = Bit is unknown	-n/n = Value at POR and BOR/Value at all other Resets
'1' = Bit is set	'0' = Bit is cleared	

bit 7      **Unimplemented:** Read as '0'

bit 6-4    **ADCS<2:0>:** A/D Conversion Clock Select bits

000 = Fosc/2

001 = Fosc/8

010 = Fosc/32

011 = FRC (clock supplied from an internal oscillator with a divisor of 16)

100 = Fosc/4

101 = Fosc/16

110 = Fosc/64

bit 3-1    **Unimplemented:** Read as '0'

bit 0      **ADPREF1:** ADC Positive Voltage Reference Selection bit

0 = VDD

1 = VREF+

# PIC16F753/HV753

## REGISTER 12-3: ADRESH: ADC RESULT REGISTER HIGH (ADRESH) ADFM = 0 (READ-ONLY)

R-x	R-x	R-x	R-x	R-x	R-x	R-x	R-x
ADRESH<9:2>							
bit 7							bit 0

**Legend:**

R = Readable bit                      W = Writable bit                      U = Unimplemented bit, read as '0'  
 -n = Value at POR                      '1' = Bit is set                      '0' = Bit is cleared                      x = Bit is unknown

bit 7-0                      **ADRESH<9:2>**: ADC Result Register bits  
 Upper eight bits of 10-bit conversion result

## REGISTER 12-4: ADRESL: ADC RESULT REGISTER LOW (ADRESL) ADFM = 0 (READ-ONLY)

R-x	R-x	U-0	U-0	U-0	U-0	U-0	U-0
ADRESL<7:0>							
bit 7							bit 0

**Legend:**

R = Readable bit                      W = Writable bit                      U = Unimplemented bit, read as '0'  
 -n = Value at POR                      '1' = Bit is set                      '0' = Bit is cleared                      x = Bit is unknown

bit 7-0                      **ADRESL<7:0>**: ADC Result Register bits  
 Lower two bits of 10-bit conversion result

## REGISTER 12-5: ADRESH: ADC RESULT REGISTER HIGH (ADRESH) ADFM = 1 (READ-ONLY)

U-0	U-0	U-0	U-0	U-0	U-0	R-x	R-x
—	—	—	—	—	—	ADRESH<9:8>	
bit 7							bit 0

**Legend:**

R = Readable bit                      W = Writable bit                      U = Unimplemented bit, read as '0'  
 -n = Value at POR                      '1' = Bit is set                      '0' = Bit is cleared                      x = Bit is unknown

bit 7-2                      **Unimplemented:** Read as '0'  
 bit 1-0                      **ADRESH<9:8>**: ADC Result Register bits  
 Upper two bits of 10-bit conversion result

## REGISTER 12-6: ADRESL: ADC RESULT REGISTER LOW (ADRESL) ADFM = 1 (READ-ONLY)

R-x	R-x	R-x	R-x	R-x	R-x	R-x	R-x
ADRESL<7:0>							
bit 7							bit 0

**Legend:**

R = Readable bit                      W = Writable bit                      U = Unimplemented bit, read as '0'  
 -n = Value at POR                      '1' = Bit is set                      '0' = Bit is cleared                      x = Bit is unknown

bit 7-0                      **ADRESL<7:0>**: ADC Result Register bits  
 Lower eight bits of 10-bit conversion result



## 12.4 A/D Acquisition Requirements

For the ADC to meet its specified accuracy, the charge holding capacitor (CHOLD) must be allowed to fully charge to the input channel voltage level. The Analog Input model is shown in Figure 12-4. The source impedance (RS) and the internal sampling switch (RSS) impedance directly affect the time required to charge the capacitor CHOLD. The sampling switch (RSS) impedance varies over the device voltage (VDD), see Figure 12-4. **The maximum recommended impedance for analog sources is 10 kΩ.** As the source impedance is decreased, the acquisition time may be decreased. After the analog input channel is selected (or changed),

an A/D acquisition must be done before the conversion can be started. To calculate the minimum acquisition time, Equation 12-1 may be used. This equation assumes that 1/2 LSB error is used (1024 steps for the ADC). The 1/2 LSB error is the maximum error allowed for the ADC to meet its specified resolution.

### EQUATION 12-1: ACQUISITION TIME EXAMPLE

*Assumptions: Temperature = 50°C and external impedance of 10kΩ 5.0V VDD*

$$\begin{aligned} T_{ACQ} &= \text{Amplifier Settling Time} + \text{Hold Capacitor Charging Time} + \text{Temperature Coefficient} \\ &= T_{AMP} + T_C + T_{COFF} \\ &= 2\mu s + T_C + [(Temperature - 25^\circ C)(0.05\mu s/^\circ C)] \end{aligned}$$

*The value for TC can be approximated with the following equations:*

$$V_{APPLIED} \left( 1 - \frac{1}{2047} \right) = V_{CHOLD} \quad ;[1] \text{ } V_{CHOLD} \text{ charged to within } 1/2 \text{ lsb}$$

$$V_{APPLIED} \left( 1 - e^{-\frac{T_C}{RC}} \right) = V_{CHOLD} \quad ;[2] \text{ } V_{CHOLD} \text{ charge response to } V_{APPLIED}$$

$$V_{APPLIED} \left( 1 - e^{-\frac{T_C}{RC}} \right) = V_{APPLIED} \left( 1 - \frac{1}{2047} \right) \quad ;\text{combining [1] and [2]}$$

*Solving for TC:*

$$\begin{aligned} T_C &= -CHOLD(RIC + RSS + RS) \ln(1/2047) \\ &= -10pF(1k\Omega + 7k\Omega + 10k\Omega) \ln(0.0004885) \\ &= 1.37\mu s \end{aligned}$$

*Therefore:*

$$\begin{aligned} T_{ACQ} &= 2\mu s + 1.37\mu s + [(50^\circ C - 25^\circ C)(0.05\mu s/^\circ C)] \\ &= 4.67\mu s \end{aligned}$$

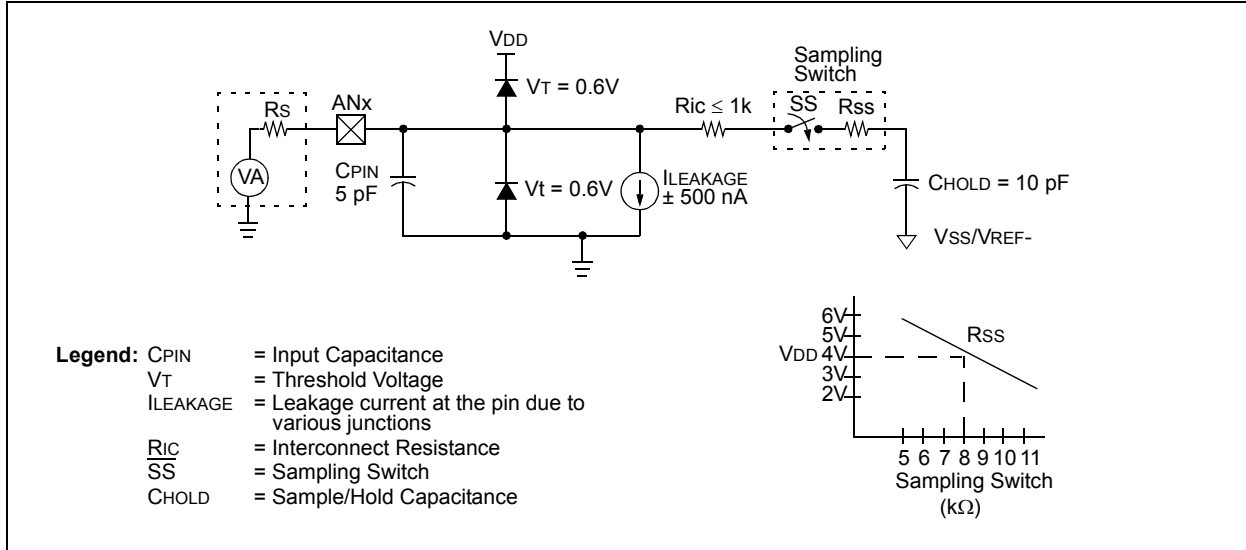
**Note 1:** The reference voltage (VREF) has no effect on the equation, since it cancels itself out.

**2:** The charge holding capacitor (CHOLD) is not discharged after each conversion.

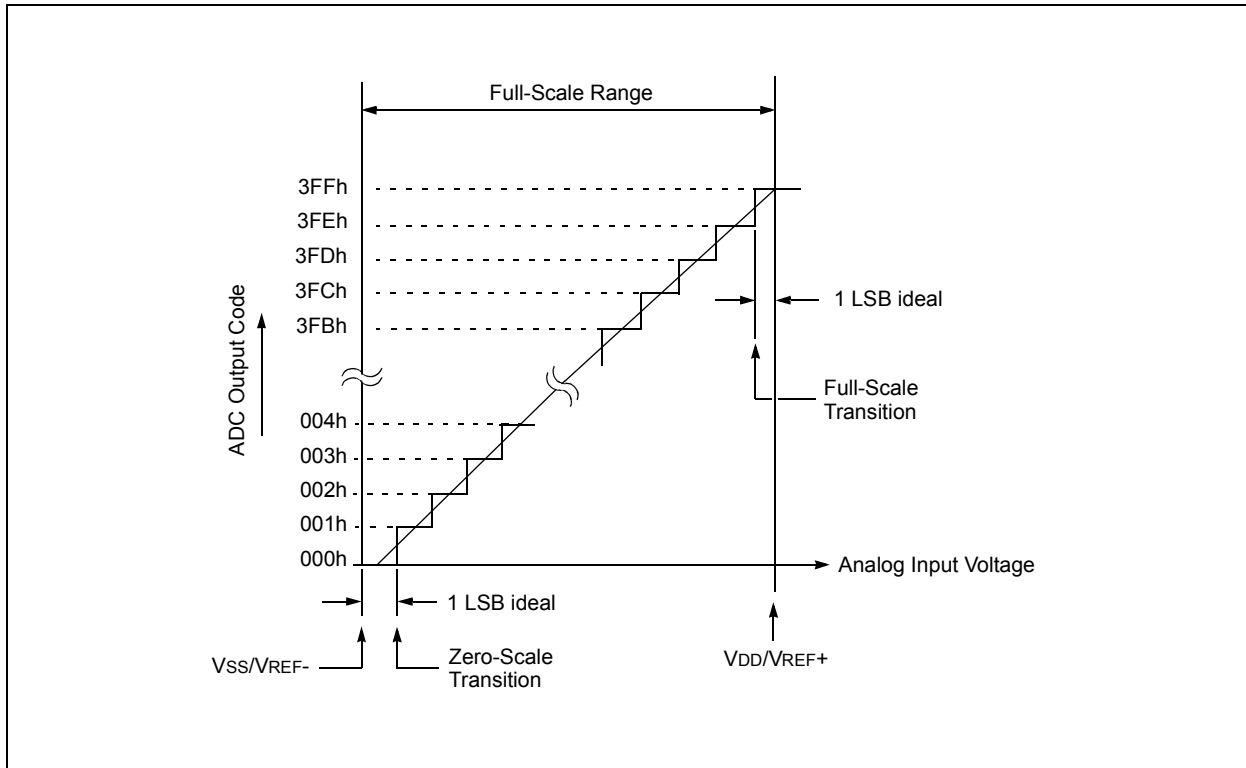
**3:** The maximum recommended impedance for analog sources is 10 kΩ. This is required to meet the pin leakage specification.

# PIC16F753/HV753

**FIGURE 12-4: ANALOG INPUT MODEL**



**FIGURE 12-5: ADC TRANSFER FUNCTION**



**TABLE 12-2: SUMMARY OF ASSOCIATED ADC REGISTERS**

Name	Bit 7	Bit 6	Bit 5	Bit 4	Bit 3	Bit 2	Bit 1	Bit 0	Register on Page
ADCON0	ADFM	—	CHS<3:0>				GO/DONE	ADON	118
ADCON1	—	ADCS<2:0>			—	—	—	ADPREF1	119
ANSELA	—	—	—	ANSA4	—	ANSA2	ANSA1	ANSA0	48
ADRESH <sup>(2)</sup>	Most Significant eight bits of the left shifted A/D result or two bits of the right shifted result								120*
ADRESL <sup>(2)</sup>	Least Significant two bits of the left shifted result or eight bits of the right shifted result								118*
PORTA	—	—	RA5	RA4	RA3	RA2	RA1	RA0	46
INTCON	GIE	PEIE	T0IE	INTE	IOCIE	T0IF	INTF	IOCIF	19
PIE1	TMR1GIE	ADIE	—	—	HLTMR2IE	HLTMR1IE	TMR2IE	TMR1IE	20
PIR1	TMR1GIF	ADIF	—	—	HLTMR2IF	HLTMR1IF	TMR2IF	TMR1IF	22
TRISA	—	—	TRISA5	TRISA4	TRISA3 <sup>(1)</sup>	TRISA2	TRISA1	TRISA0	46

**Legend:** x = unknown, u = unchanged, — = unimplemented read as '0'. Shaded cells are not used for ADC module.

\* Page provides register information.

**Note 1:** TRISA3 always reads '1'.

**2:** Read-only register.

# PIC16F753/HV753

---

NOTES:

## 13.0 FIXED VOLTAGE REFERENCE (FVR)

The Fixed Voltage Reference (FVR) is a stable voltage reference, independent of VDD, with 1.2V output level. The output of the FVR can be configured to supply a reference voltage to the following:

- ADC input channel
- Comparator 1 positive input (C1VP)
- Comparator 2 positive input (C2VP)
- REFOUT pin
- Shunt regulator

On the PIC16F753, the FVR is enabled by setting the FVREN bit of the FVRCON register. The FVR is always enabled on the PIC16HV753 device.

### 13.1 Fixed Voltage Reference Output

The FVR output can be applied to the REFOUT pin by setting the FVRBUFSS and FVRBUFEN bits of the FVRCON register. The FVRBUFSS bit selects the op amp, FVR or DAC output reference to the REFOUT pin buffer. The FVRBUFEN bit enables the output buffer to the REFOUT pin.

Enabling the REFOUT pin automatically overrides any digital input or output functions of the pin. Reading the REFOUT pin when it has been configured for a reference voltage output will always return a '0'.

### 13.2 FVR Stabilization Period

When the Fixed Voltage Reference module is enabled, it requires time for the reference circuit to stabilize. Once the circuit stabilizes and is ready for use, the FVRRDY bit of the FVRCON register will be set. See **Section 22.0 "Electrical Specifications"** for the minimum delay requirement.

### 13.3 Operation During Sleep

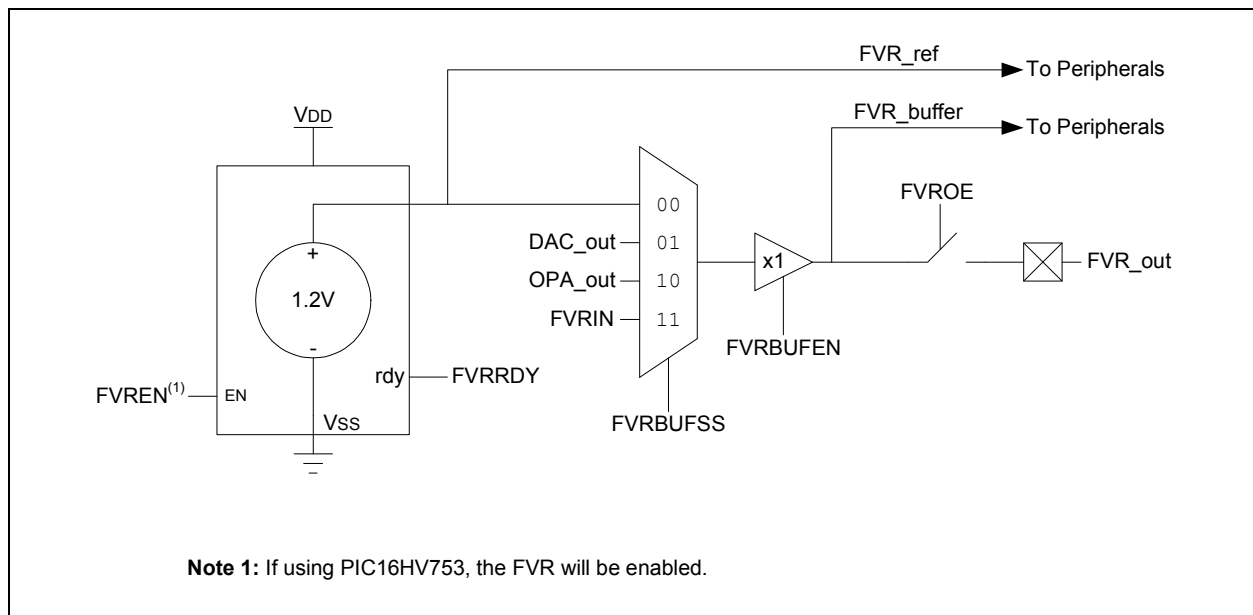
When the device wakes up from Sleep through an interrupt or a Watchdog Timer time-out, the contents of the FVRCON register are not affected. To minimize current consumption in Sleep mode, the FVR voltage reference should be disabled.

### 13.4 Effects of a Reset

A device Reset clears the FVRCON register. As a result:

- The FVR module is disabled
- The FVR voltage output is disabled on the REFOUT pin

**FIGURE 13-1: VOLTAGE REFERENCE BLOCK DIAGRAM**



# PIC16F753/HV753

## 13.5 Register Definitions: FVR Control

**REGISTER 13-1: FVR1CON0: FIXED VOLTAGE REFERENCE CONTROL REGISTER**

R/W-0/0	R-q/q	R/W-0/0	R/W-0/0	R/W-0/0	U-0	U-0	R/W-0/0
FVREN	FVRRDY	FVROE	FVRBUFSS1	FVRBUFSS0	—	—	FVRBUFEN
bit 7							bit 0

**Legend:**

R = Readable bit	W = Writable bit	U = Unimplemented bit, read as '0'
u = Bit is unchanged	x = Bit is unknown	-n/n = Value at POR and BOR/Value at all other Resets
'1' = Bit is set	'0' = Bit is cleared	q = Value depends on condition

- bit 7      **FVREN:** Fixed Voltage Reference Enable bit  
0 = Fixed Voltage Reference is disabled  
1 = Fixed Voltage Reference is enabled
- bit 6      **FVRRDY:** Fixed Voltage Reference Ready Flag bit  
0 = Fixed Voltage Reference output is not ready or not enabled bit  
1 = Fixed Voltage Reference output is ready for use
- bit 5      **FVROE:** Voltage Reference Output Pin Buffer Enable bit  
0 = Output pass gate is disabled  
1 = Output pass gate is enabled
- bit 4-3    **FVRBUFSS<1:0>:** Voltage Reference Pin Buffer Source Select bits  
00 = Selects the output of the band gap as the input  
01 = DAC output  
10 = Op amp buffered output  
11 = Selects FVRIN (RA1)
- bit 2-1    **Unimplemented:** Read as '0'
- bit 0      **FVRBUFEN:** Voltage Reference Output Pin Buffer Enable bit  
0 = Output buffer is disabled  
1 = Output buffer is enabled

**TABLE 13-1: SUMMARY OF REGISTERS ASSOCIATED WITH FIXED VOLTAGE REFERENCE**

Name	Bit 7	Bit 6	Bit 5	Bit 4	Bit 3	Bit 2	Bit 1	Bit 0	Register on Page
FVR1CON0	FVREN	FVRRDY	FVROE	FVRBUFSS1	FVRBUFSS0	—	—	FVRBUFEN	126

**Legend:** Shaded cells are not used with the Fixed Voltage Reference.

## 14.0 DIGITAL-TO-ANALOG CONVERTER (DAC) MODULE

The Digital-to-Analog Converter supplies a variable voltage reference, ratiometric with the input source, with 512 selectable output levels.

The input of the DAC can be connected to:

- External VREF pins
- VDD supply voltage
- FVR (Fixed Voltage Reference)

The output of the DAC can be configured to supply a reference voltage to the following:

- Comparator positive input
- ADC input channel
- DACxOUT pin
- Op amp

The Digital-to-Analog Converter (DAC) is enabled by setting the DACEN bit of the DACxCON0 register.

## 14.1 Output Voltage Selection

The DAC has 512 voltage level ranges. The 512 levels are set with the DACR<8:1> bits of the DACxREFH register and DACR0 of the DACxREFL.

The DAC output voltage is determined by [Equation 14-1](#):

### EQUATION 14-1: DAC OUTPUT VOLTAGE

*IF DACEN = 1*

$$V_{OUT} = \left( (V_{SOURCE+} - V_{SOURCE-}) \times \frac{DACR[8]}{2^9} \right) + V_{SOURCE-}$$

*V<sub>SOURCE+</sub> = V<sub>DD</sub>, V<sub>REF</sub>, OPA1OUT or FVR BUFFER 2*

*V<sub>SOURCE-</sub> = V<sub>SS</sub>*

## 14.2 Ratiometric Output Level

The DAC output value is derived using a resistor ladder with each end of the ladder tied to a positive and negative voltage reference input source. If the voltage of either input source fluctuates, a similar fluctuation will result in the DAC output value.

The value of the individual resistors within the ladder can be found in [Section 22.0 “Electrical Specifications”](#).

## 14.3 DAC Voltage Reference Output

The DAC voltage can be output to the DACxOUT pins by setting the DACOE1 bit of the DACxCON0 register. Selecting the DAC reference voltage for output on the DACxOUT pin automatically overrides the digital output buffer and digital input threshold detector functions of that pin. Reading the DACxOUT pin when it has been configured for DAC reference voltage output will always return a ‘0’.

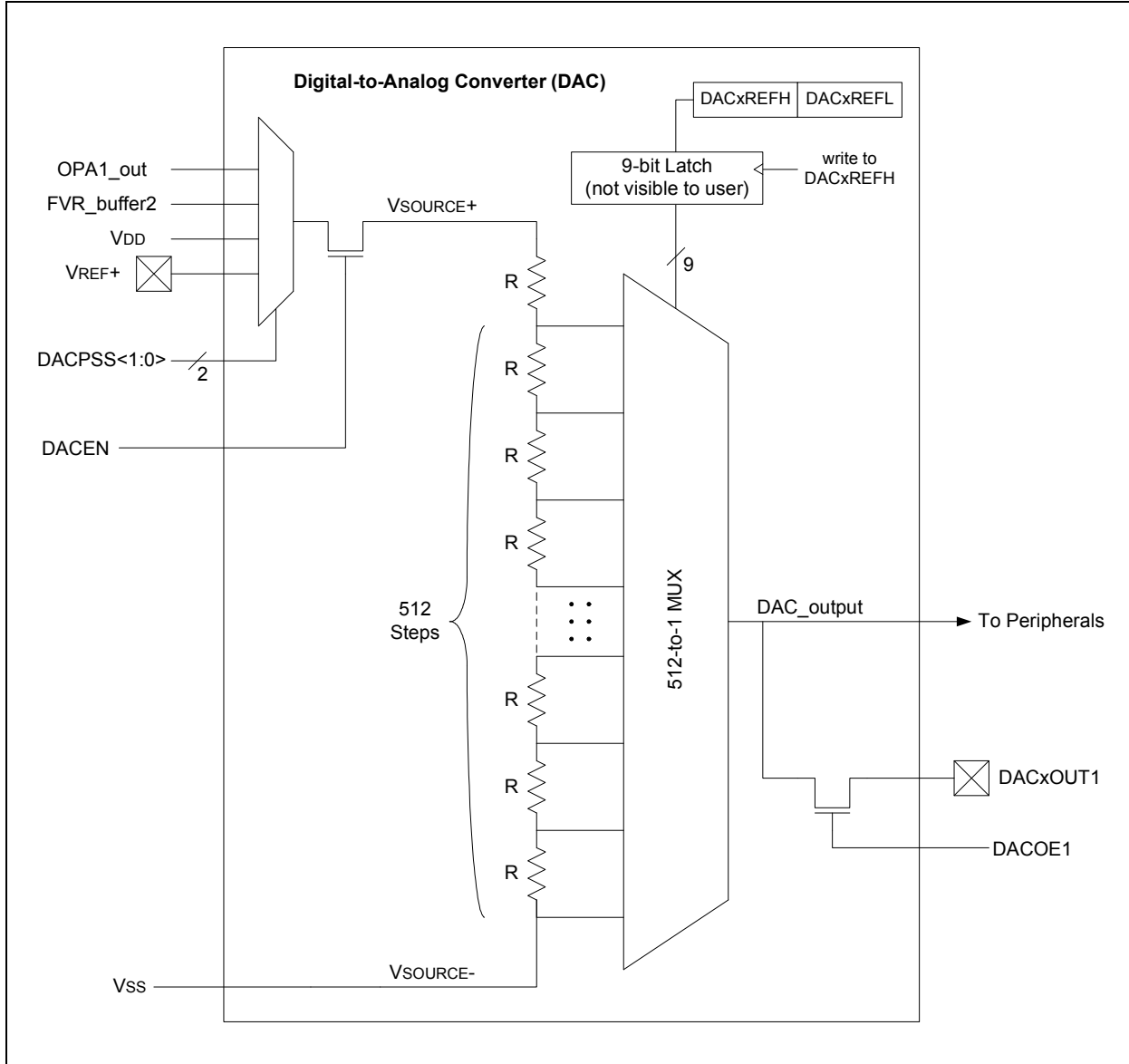
Due to the limited current drive capability, a buffer must be used on the DAC voltage reference output for external connections to either DACxOUT pin. [Figure 14-2](#) shows a buffering technique example.

## 14.4 DAC Justification

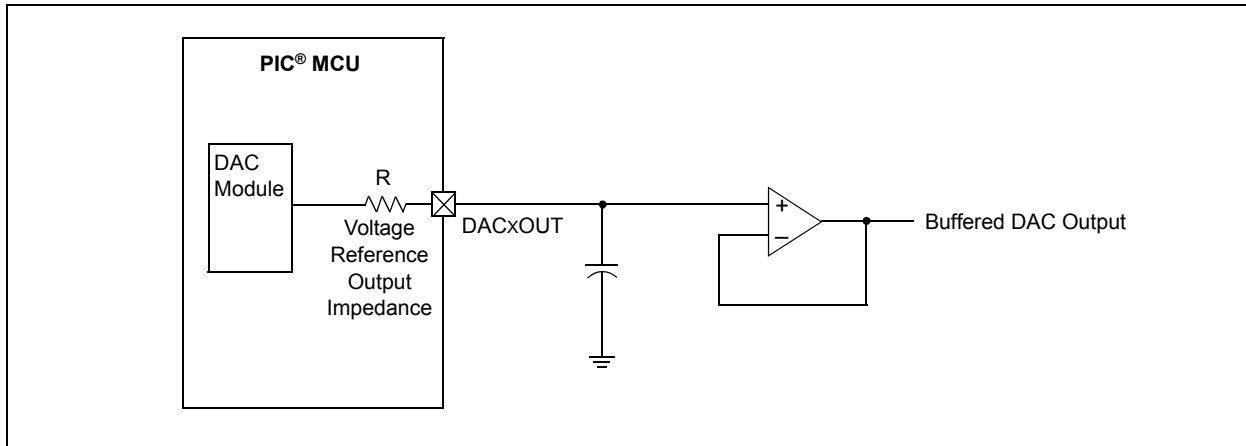
The DAC can be configured to be left or right justified based on application needs. In order for justification to work properly, all 16 bits of the DAC buffer register (DACxREFH:DACxREFL register pair) must be loaded in the correct sequence to get the effective 9-bit result. In most applications, DACxREFL is written prior to DACxREFH, regardless of justification. The DAC buffer is loaded at the end of the write cycle that writes DACxREFH register.

# PIC16F753/HV753

**FIGURE 14-1: DIGITAL-TO-ANALOG CONVERTER BLOCK DIAGRAM**



**FIGURE 14-2: VOLTAGE REFERENCE OUTPUT BUFFER EXAMPLE**





## 14.5 Operation During Sleep

When the device wakes up from Sleep through an interrupt or a Watchdog Timer time-out, the contents of the DACxCON0 register are not affected. To minimize current consumption in Sleep mode, the voltage reference should be disabled.

## 14.6 Effects of a Reset

A device Reset affects the following:

- DAC is disabled
- DAC output voltage is removed from the DACxOUT pin
- The DACR<8:0> range select bits are cleared

# PIC16F753/HV753

## 14.7 Register Definitions: DAC Control

### REGISTER 14-1: DACxCON0: VOLTAGE REFERENCE CONTROL REGISTER 0

R/W-0/0	R/W-0/0	R/W-0/0	U-0	R/W-0/0	R/W-0/0	U-0	U-0
DACEN	DACFM	DACOE	—	DACPSS<1:0>		—	—
bit 7						bit 0	

#### Legend:

R = Readable bit	W = Writable bit	U = Unimplemented bit, read as '0'
u = Bit is unchanged	x = Bit is unknown	-n/n = Value at POR and BOR/Value at all other Resets
'1' = Bit is set	'0' = Bit is cleared	

- bit 7      **DACEN:** DAC Enable bit  
1 = DACx is enabled  
0 = DACx is disabled
- bit 6      **DACFM:** DAC Output Format bit  
1 = DACx output result is right justified  
0 = DACx output result is left justified
- bit 5      **DACOE:** DAC Voltage Output Enable bit  
1 = DACx voltage level is also an output on the DACxOUT pin  
0 = DACx voltage level is disconnected from the DACxOUT pin
- bit 4      **Unimplemented:** Read as '0'
- bit 3-2    **DACPSS<1:0>:** DAC Positive Source Select bits  
11 = FVR output  
10 = VREF+ pin  
01 = OPA1OUT pin  
00 = VDD
- bit 1-0    **Unimplemented:** Read as '0'

## REGISTER 14-2: DACxREFH: DAC REFERENCE HIGH REGISTER (DACxFM = 0)

R/W-0/0	R/W-0/0	R/W-0/0	R/W-0/0	R/W-0/0	R/W-0/0	R/W-0/0	R/W-0/0
DACR<8:1>							
bit 7							bit 0

### Legend:

R = Readable bit	W = Writable bit	U = Unimplemented bit, read as '0'
u = Bit is unchanged	x = Bit is unknown	-n/n = Value at POR and BOR/Value at all other Resets
'1' = Bit is set	'0' = Bit is cleared	

bit 7-0      **DACR<8:1>**: DAC Reference Selection bits  
 $DACxOUT = (DACR<8:0> \times V_{dac\_ref})/512$

## REGISTER 14-3: DACxREFL: DAC REFERENCE LOW REGISTER (DACxFM = 0)

R/W-0/0	U-0	U-0	U-0	U-0	U-0	U-0	U-0
DACR0	—	—	—	—	—	—	—
bit 7							bit 0

### Legend:

R = Readable bit	W = Writable bit	U = Unimplemented bit, read as '0'
u = Bit is unchanged	x = Bit is unknown	-n/n = Value at POR and BOR/Value at all other Resets
'1' = Bit is set	'0' = Bit is cleared	

bit 7      **DACR0**: DAC Reference Selection bits  
 $DACxOUT = (DACR<8:0> \times V_{dac\_ref})/512$

bit 6-0      **Unimplemented**: Read as '0'

# PIC16F753/HV753

**REGISTER 14-4: DACxREFH: DAC REFERENCE HIGH REGISTER (DACxFM = 1)**

U-0	U-0	U-0	U-0	U-0	U-0	U-0	R/W-0/0
—	—	—	—	—	—	—	DACR8
bit 7							bit 0

**Legend:**

R = Readable bit                      W = Writable bit                      U = Unimplemented bit, read as '0'  
u = Bit is unchanged                  x = Bit is unknown                  -n/n = Value at POR and BOR/Value at all other Resets  
'1' = Bit is set                            '0' = Bit is cleared

bit 7-1            **Unimplemented:** Read as '0'  
bit 0              **DACR8:** DAC Reference Selection bits  
DACxOUT = (DACR<8:0> x (Vdac\_ref) / 512)

**REGISTER 14-5: DACxREFL: DAC REFERENCE LOW REGISTER (DACxFM = 1)**

R/W-0/0	R/W-0/0	R/W-0/0	R/W-0/0	R/W-0/0	R/W-0/0	R/W-0/0	R/W-0/0
DACR<7:0>							
bit 7							bit 0

**Legend:**

R = Readable bit                      W = Writable bit                      U = Unimplemented bit, read as '0'  
u = Bit is unchanged                  x = Bit is unknown                  -n/n = Value at POR and BOR/Value at all other Resets  
'1' = Bit is set                            '0' = Bit is cleared

bit 7-0            **DACR<7:0>:** DAC Reference Selection bits  
DACxOUT = (DACR<8:0> x (Vdac\_ref) / 512)

**TABLE 14-1: SUMMARY OF REGISTERS ASSOCIATED WITH THE DAC MODULE**

Name	Bit 7	Bit 6	Bit 5	Bit 4	Bit 3	Bit 2	Bit 1	Bit 0	Register on Page
DACxCON0	DACEN	DACFM	DACOE	—	DACPSS<1:0>		—	—	130
DACxREFH	DACR<8:1>								131
DACxREFH	—	—	—	—	—	—	—	DACR8	132
DACxREFL	DACR<7:0>								131
DACxREFL	DACR0	—	—	—	—	—	—	—	132

**Legend:** — = Unimplemented location, read as '0'. Shaded cells are not used with the DAC module.

## 15.0 COMPARATOR MODULE

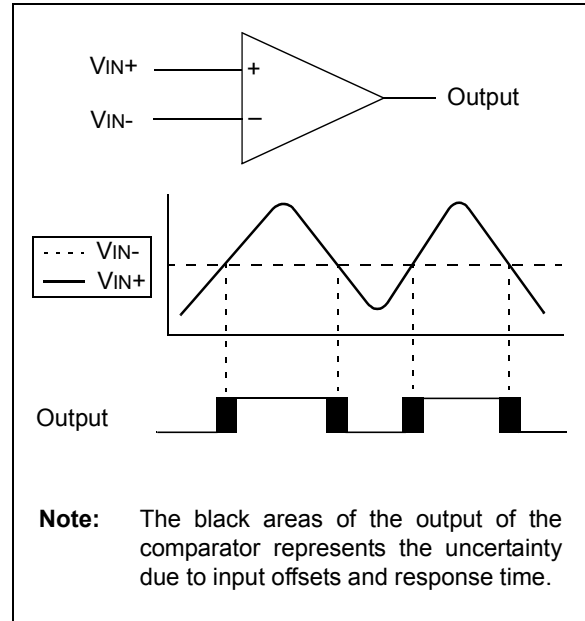
Comparators are used to interface analog circuits to a digital circuit by comparing two analog voltages and providing a digital indication of their relative magnitudes. Comparators are very useful mixed-signal building blocks because they provide analog functionality independent of program execution. The analog comparator module includes the following features:

- Independent comparator control
- Programmable input selection
- Comparator output is available internally/externally
- Programmable output polarity
- Interrupt-on-change
- Wake-up from Sleep
- Programmable Speed/Power optimization
- PWM shutdown
- Programmable and Fixed Voltage Reference

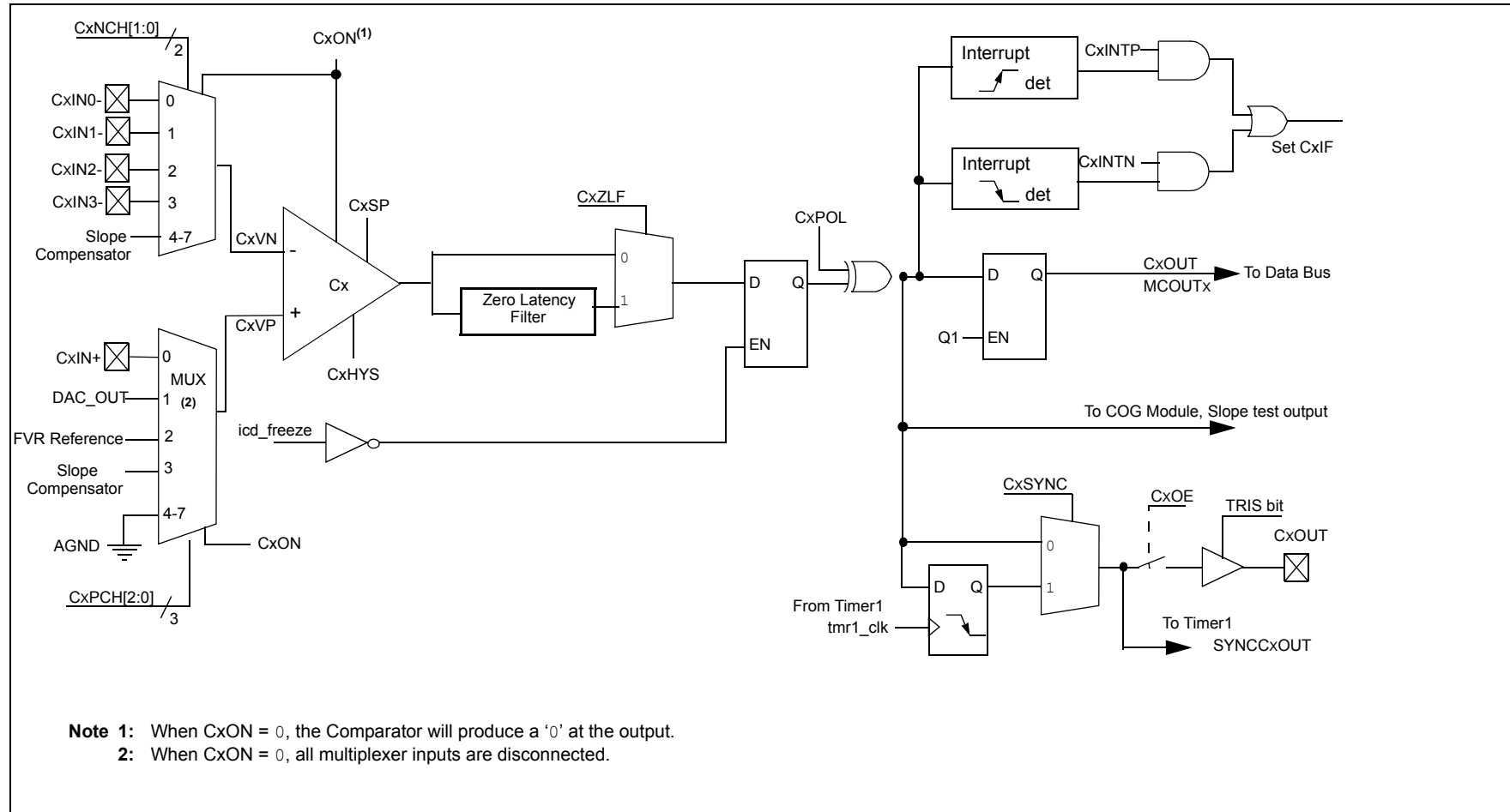
### 15.1 Comparator Overview

A single comparator is shown in [Figure 15-1](#) along with the relationship between the analog input levels and the digital output. When the analog voltage at  $V_{IN+}$  is less than the analog voltage at  $V_{IN-}$ , the output of the comparator is a digital low level. When the analog voltage at  $V_{IN+}$  is greater than the analog voltage at  $V_{IN-}$ , the output of the comparator is a digital high level.

FIGURE 15-1: SINGLE COMPARATOR



**FIGURE 15-2: COMPARATOR MODULE SIMPLIFIED BLOCK DIAGRAM**



## 15.2 Comparator Control

Each comparator has two control registers: CMxCON0 and CMxCON1.

The CMxCON0 registers (see [Register 15-1](#)) contain Control and Status bits for the following:

- Enable
- Output selection
- Output pin enable
- Output polarity
- Speed/Power selection
- Hysteresis enable
- Output synchronization

The CMxCON1 registers (see [Register 15-2](#)) contain Control bits for the following:

- Interrupt edge polarity (rising and/or falling)
- Positive input channel selection
- Negative input channel selection

### 15.2.1 COMPARATOR ENABLE

Setting the CxON bit of the CMxCON0 register enables the comparator for operation. Clearing the CxON bit disables the comparator resulting in minimum current consumption.

### 15.2.2 COMPARATOR OUTPUT SELECTION

The output of the comparator can be monitored by reading either the CxOUT bit of the CMxCON0 register or the MCOUTx bit of the CMOUT register. In order to make the output available for an external connection, the following conditions must be true:

- CxOE bit of the CMxCON0 register must be set
- Corresponding TRIS bit must be cleared
- CxON bit of the CMxCON0 register must be set

- Note 1:** The CxOE bit of the CMxCON0 register overrides the PORT data latch. Setting the CxON bit of the CMxCON0 register has no impact on the port override.
- 2:** The internal output of the comparator is latched with each instruction cycle. Unless otherwise specified, external outputs are not latched.

### 15.2.3 COMPARATOR OUTPUT POLARITY

Inverting the output of the comparator is functionally equivalent to swapping the comparator inputs. The polarity of the comparator output can be inverted by setting the CxPOL bit of the CMxCON0 register. Clearing the CxPOL bit results in a non-inverted output.

[Table 15-1](#) shows the output state versus input conditions, including polarity control.

**TABLE 15-1: COMPARATOR OUTPUT STATE VS. INPUT CONDITIONS**

Input Condition	CxPOL	CxOUT
$CxVN > CxVP$	0	0
$CxVN < CxVP$	0	1
$CxVN > CxVP$	1	1
$CxVN < CxVP$	1	0

### 15.2.4 COMPARATOR SPEED/POWER SELECTION

The trade-off between speed or power can be optimized during program execution with the CxSP control bit. The default state for this bit is '1' which selects the normal speed mode. Device power consumption can be optimized at the cost of slower comparator propagation delay by clearing the CxSP bit to '0'.

## 15.3 Comparator Hysteresis

A selectable amount of separation voltage can be added to the input pins of each comparator to provide a hysteresis function to the overall operation. Hysteresis is enabled by setting the CxHYS bit of the CMxCON0 register.

See [Section 22.0 "Electrical Specifications"](#) for more information.

## 15.4 Timer1 Gate Operation

The output resulting from a comparator operation can be used as a source for gate control of Timer1. See [Section 7.5 "Timer1 Gate"](#) for more information. This feature is useful for timing the duration or interval of an analog event.

It is recommended that the comparator output be synchronized to Timer1. This ensures that Timer1 does not increment while a change in the comparator is occurring.

# PIC16F753/HV753

## 15.4.1 COMPARATOR OUTPUT SYNCHRONIZATION

The output from either comparator, C1 or C2, can be synchronized with Timer1 by setting the CxSYNC bit of the CMxCON0 register.

Once enabled, the comparator output is latched on the falling edge of the Timer1 source clock. If a prescaler is used with Timer1, the comparator output is latched after the prescaling function. To prevent a race condition, the comparator output is latched on the falling edge of the Timer1 clock source and Timer1 increments on the rising edge of its clock source. See the Comparator Block Diagram (Figure 15-2) and the Timer1 Block Diagram (Figure 7-1) for more information.

## 15.5 Comparator Interrupt

An interrupt can be generated upon a change in the output value of the comparator for each comparator, a rising edge detector and a falling edge detector are present.

When either edge detector is triggered and its associated enable bit is set (CxINTP and/or CxINTN bits of the CMxCON1 register), the Corresponding Interrupt Flag bit (CxIF bit of the PIR2 register) will be set.

To enable the interrupt, you must set the following bits:

- CxON, CxPOL and CxSP bits of the CMxCON0 register
- CxIE bit of the PIE2 register
- CxINTP bit of the CMxCON1 register (for a rising edge detection)
- CxINTN bit of the CMxCON1 register (for a falling edge detection)
- PEIE and GIE bits of the INTCON register

The associated interrupt flag bit, CxIF bit of the PIR2 register, must be cleared in software. If another edge is detected while this flag is being cleared, the flag will still be set at the end of the sequence.

**Note:** Although a comparator is disabled, an interrupt can be generated by changing the output polarity with the CxPOL bit of the CMxCON0 register, or by switching the comparator on or off with the CxON bit of the CMxCON0 register.

## 15.6 Comparator Positive Input Selection

Configuring the CxPCH<1:0> bits of the CMxCON1 register directs an internal voltage reference or an analog pin to the non-inverting input of the comparator:

- CxIN0+ analog pin
- DAC Reference Voltage (dac\_ref)
- FVR Reference Voltage (fvr\_ref)
- Vss (Ground)

See [Section 13.0 “Fixed Voltage Reference \(FVR\)”](#) for more information on the Fixed Voltage Reference module.

See [Section 14.0 “Digital-to-Analog Converter \(DAC\) Module”](#) for more information on the DAC input signal.

Any time the comparator is disabled (CxON = 0), all comparator inputs are disabled.

## 15.7 Comparator Negative Input Selection

The CxNCH0 bit of the CMxCON0 register selects the analog input pin to the comparator inverting input.

**Note:** To use CxIN0+ and CxIN1x- pins as analog input, the appropriate bits must be set in the ANSEL register and the corresponding TRIS bits must also be set to disable the output drivers.

## 15.8 Comparator Response Time

The comparator output is indeterminate for a period of time after the change of an input source or the selection of a new reference voltage. This period is referred to as the response time. The response time of the comparator differs from the settling time of the voltage reference. Therefore, both of these times must be considered when determining the total response time to a comparator input change. See the Comparator and Voltage Reference Specifications in [Section 22.0 “Electrical Specifications”](#) for more details.

## 15.9 Interaction with the COG Module

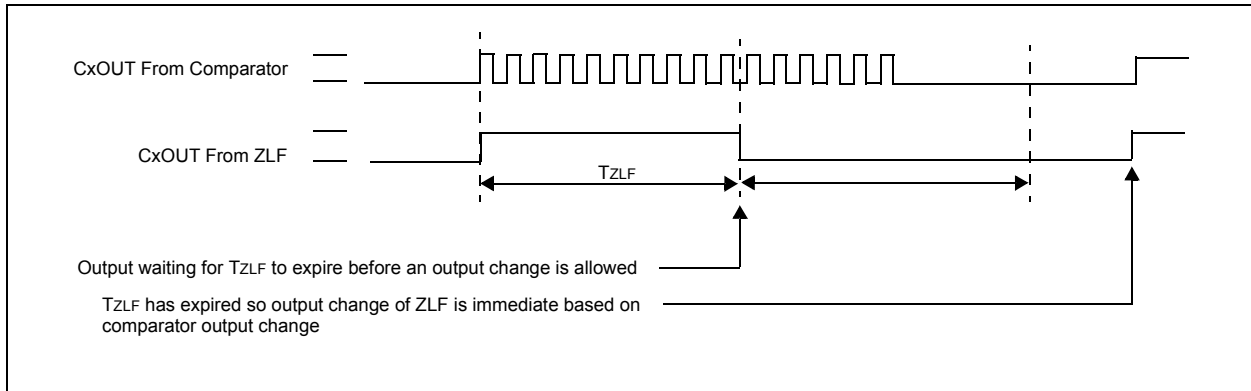
The comparator outputs can be brought to the COG module in order to facilitate auto-shutdown. If auto-restart is also enabled, the comparators can be configured as a closed loop analog feedback to the COG, thereby creating an analog controlled PWM.



## 15.10 Zero Latency Filter

In high-speed operation, and under proper circuit conditions, it is possible for the comparator output to oscillate. This oscillation can have adverse effects on the hardware and software relying on this signal. Therefore, a digital filter has been added to the comparator output to suppress the comparator output oscillation. Once the comparator output changes, the output is prevented from reversing the change for a nominal time of 20 ns. This allows the comparator output to stabilize without affecting other dependent devices. Refer to [Figure 15-3](#).

**FIGURE 15-3: COMPARATOR ZERO LATENCY FILTER OPERATION**



# PIC16F753/HV753

## 15.11 Analog Input Connection Considerations

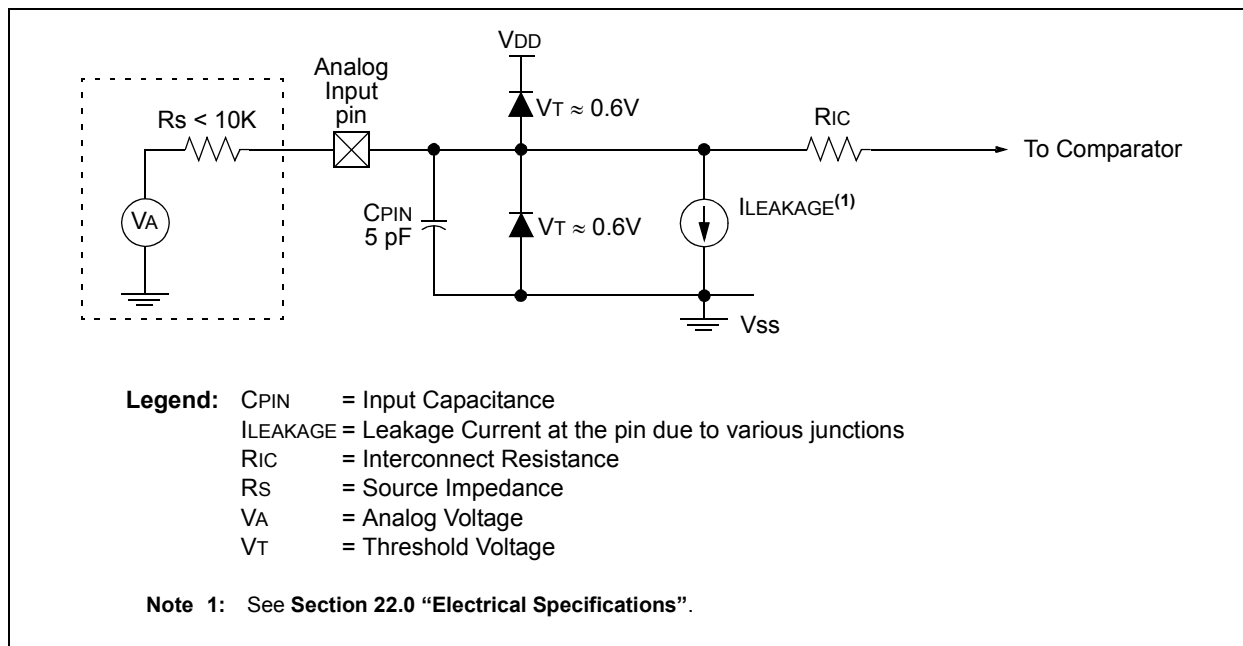
A simplified circuit for an analog input is shown in Figure 15-4. Since the analog input pins share their connection with a digital input, they have reverse biased ESD protection diodes to VDD and VSS. The analog input, therefore, must be between VSS and VDD. If the input voltage deviates from this range by more than 0.6V in either direction, one of the diodes is forward biased and a latch-up may occur.

A maximum source impedance of 10 kΩ is recommended for the analog sources. Also, any external component connected to an analog input pin, such as a capacitor or a Zener diode, should have very little leakage current to minimize inaccuracies introduced.

**Note 1:** When reading a PORT register, all pins configured as analog inputs will read as a '0'. Pins configured as digital inputs will convert as an analog input, according to the input specification.

**2:** Analog levels on any pin defined as a digital input, may cause the input buffer to consume more current than is specified.

**FIGURE 15-4: ANALOG INPUT MODEL**



## 15.12 Register Definitions: Comparator Control

**REGISTER 15-1: CMxCON0: COMPARATOR Cx CONTROL REGISTER 0**

R/W-0/0	R-0/0	R/W-0/0	R/W-0/0	R/W-0/0	R/W-1/1	R/W-0/0	R/W-0/0
CxON	CxOUT	CxOE	CxPOL	CxZLF	CxSP	CxHYS	CxSYNC
bit 7							bit 0

**Legend:**

R = Readable bit	W = Writable bit	U = Unimplemented bit, read as '0'
u = Bit is unchanged	x = Bit is unknown	-n/n = Value at POR and BOR/Value at all other Resets
'1' = Bit is set	'0' = Bit is cleared	

- bit 7      **CxON:** Comparator Enable bit  
           1 = Comparator is enabled  
           0 = Comparator is disabled and consumes no active power
- bit 6      **CxOUT:** Comparator Output bit  
           If CxPOL = 1 (inverted polarity):  
           1 = CxVP < CxVN  
           0 = CxVP > CxVN  
           If CxPOL = 0 (non-inverted polarity):  
           1 = CxVP > CxVN  
           0 = CxVP < CxVN
- bit 5      **CxOE:** Comparator Output Enable bit  
           1 = CxOUT is present on the CxOUT pin. Requires that the associated TRIS bit be cleared to actually drive the pin. Not affected by CxON.  
           0 = CxOUT is internal only
- bit 4      **CxPOL:** Comparator Output Polarity Select bit  
           1 = Comparator output is inverted  
           0 = Comparator output is not inverted
- bit 3      **CxZLF:** Zero Latency Filter Enable bit  
           1 = Zero latency filter is enabled  
           0 = Zero latency filter is disabled
- bit 2      **CxSP:** Comparator Speed/Power Select bit  
           1 = Comparator operates in normal power, higher speed mode  
           0 = Comparator operates in low-power, low-speed mode
- bit 1      **CxHYS:** Comparator Hysteresis Enable bit  
           1 = Comparator hysteresis enabled  
           0 = Comparator hysteresis disabled
- bit 0      **CxSYNC:** Comparator Output Synchronous Mode bit  
           1 = Comparator output to Timer1 and I/O pin is synchronous to changes on Timer1 clock source. Output updated on the falling edge of Timer1 clock source.  
           0 = Comparator output to Timer1 and I/O pin is asynchronous.

# PIC16F753/HV753

## REGISTER 15-2: CMxCON1: COMPARATOR Cx CONTROL REGISTER 1

R/W-0/0	R/W-0/0	R/W-0/0	R/W-0/0	R/W-0/0	R/W-0/0	R/W-0/0	R/W-0/0
CxINTP	CxINTN	CxPCH<1:0>			CxNCH<2:0>		
bit 7							bit 0

### Legend:

R = Readable bit                      W = Writable bit                      U = Unimplemented bit, read as '0'  
u = Bit is unchanged                  x = Bit is unknown                  -n/n = Value at POR and BOR/Value at all other Resets  
'1' = Bit is set                          '0' = Bit is cleared

- bit 7            **CxINTP:** Comparator Interrupt on Positive Going Edge Enable bit  
1 = The CxIF interrupt flag will be set upon a positive going edge of the CxOUT bit  
0 = No interrupt flag will be set on a positive going edge of the CxOUT bit
- bit 6            **CxINTN:** Comparator Interrupt on Negative Going Edge Enable bit  
1 = The CxIF interrupt flag will be set upon a negative going edge of the CxOUT bit  
0 = No interrupt flag will be set on a negative going edge of the CxOUT bit
- bit 5-3        **CxPCH<1:0>:** Comparator Positive Input Channel Select bits  
000 = CxVP connects to CxIN+ pin  
001 = CxVP connects to dac\_out  
010 = CxVP connects to FVR  
011 = CxVP connects to Slope Compensator Output  
1xx = CxVP connects to AGND
- bit 2-0        **CxNCH<2:0>:** Comparator Negative Input Channel Select bits  
000 = CxVN connects to CxIN0- pin  
001 = CxVN connects to CxIN1- pin  
010 = CxVN connects to CxIN2- pin  
011 = CxVN connects to CxIN3- pin  
1xx = CxVN connects to Slope Compensator Output

## REGISTER 15-3: CMOUT: COMPARATOR OUTPUT REGISTER

U-0	U-0	U-0	U-0	U-0	U-0	R-0/0	R-0/0
—	—	—	—	—	—	MCOUT2	MCOUT1
bit 7							bit 0

### Legend:

R = Readable bit                      W = Writable bit                      U = Unimplemented bit, read as '0'  
u = Bit is unchanged                  x = Bit is unknown                  -n/n = Value at POR and BOR/Value at all other Resets  
'1' = Bit is set                          '0' = Bit is cleared

- bit 7-2        **Unimplemented:** Read as '0'
- bit 1           **MCOUT2:** Mirror Copy of C2OUT bit
- bit 0           **MCOUT1:** Mirror Copy of C1OUT bit

**TABLE 15-2: SUMMARY OF REGISTERS ASSOCIATED WITH COMPARATOR MODULE**

Name	Bit 7	Bit 6	Bit 5	Bit 4	Bit 3	Bit 2	Bit 1	Bit 0	Register on Page
CM1CON0	C1ON	C1OUT	C1OE	C1POL	C1ZLF	C1SP	C1HYS	C1SYNC	139
CM1CON1	C1INTP	C1INTN	C1PCH<2:0>			C1NCH<2:0>			140
CM2CON0	C2ON	C2OUT	C2OE	C2POL	C2ZLF	C2SP	C2HYS	C2SYNC	139
CM2CON1	C2INTP	C2INTN	C2PCH<2:0>			C2NCH<2:0>			140
CMOUT	—	—	—	—	—	—	MCOUT2	MCOUT1	140
DAC1CON0	DACEN	DACFM	DACOE	—	DACPSS1	DACPSS0	—	—	130
DAC1REFL	Least Significant bit of the left shifted result or eight bits of the right shifted DAC setting								132
FVR1CON0	FVREN	FVRRDY	FVROE	FVRBUFSS1	FVRBUFSS0	—	—	FVRBUFEN	126
INTCON	GIE	PEIE	T0IE	INTE	IOCIE	T0IF	INTF	IOCIF	19
PIE2	—	—	C2IE	C1IE	—	COG1IE	—	CCP1IE	21
PIR2	—	—	C2IF	C1IF	—	COG1IF	—	CCP1IF	23
TRISA	—	—	TRISA5	TRISA4	TRISA3 <sup>(1)</sup>	TRISA2	TRISA1	TRISA0	46
ANSELA	—	—	—	ANSA4	—	ANSA2	ANSA1	ANSA0	48

**Legend:** — = unimplemented location, read as '0'. Shaded cells are unused by the comparator module.

**Note 1:** TRISA3 always reads '1'.

# PIC16F753/HV753

---

NOTES:

## 16.0 OPERATIONAL AMPLIFIER (OPA) MODULE

The Operational Amplifier (OPA) is a standard three-terminal device requiring external feedback to operate. The OPA module has the following features:

- External Connections to I/O Ports
- Selectable Unity Gain Bandwidth Product Option
- Low Leakage Inputs
- Factory Calibrated Input Offset Voltage

### 16.1 OPAXCON0 Register

The OPAXCON0 register, shown in [Register 16-1](#), controls the OPA module.

The OPA module is enabled by setting the OPAXEN bit of the OPAXCON register. When enabled, the OPA forces the output driver of the OPAXOUT pin into tri-state to prevent contention between the driver and the OPA output.

The OPAXUGM bit of the OPAXCON register enables the Unity Gain Bandwidth mode (voltage follower) of the amplifier. In Unity Gain mode, the OPAXNCH<1:0> inputs are disabled. The default mode is normal three-terminal operation.

**Note:** When the OPA module is enabled, the OPAXOUT pin is driven by the op amp output, not by the PORT digital driver. Refer to **Section 22.0 “Electrical Specifications”** for the op amp output drive capability.

### 16.2 Effects of a Reset

A device Reset forces all registers to their Reset state. This disables the OPA module.

## 16.3 OPA Module Performance

Common AC and DC performance specifications for the OPA module:

- Common Mode Voltage Range
- Leakage Current
- Input Offset Voltage
- Open Loop Gain
- Gain Bandwidth Product

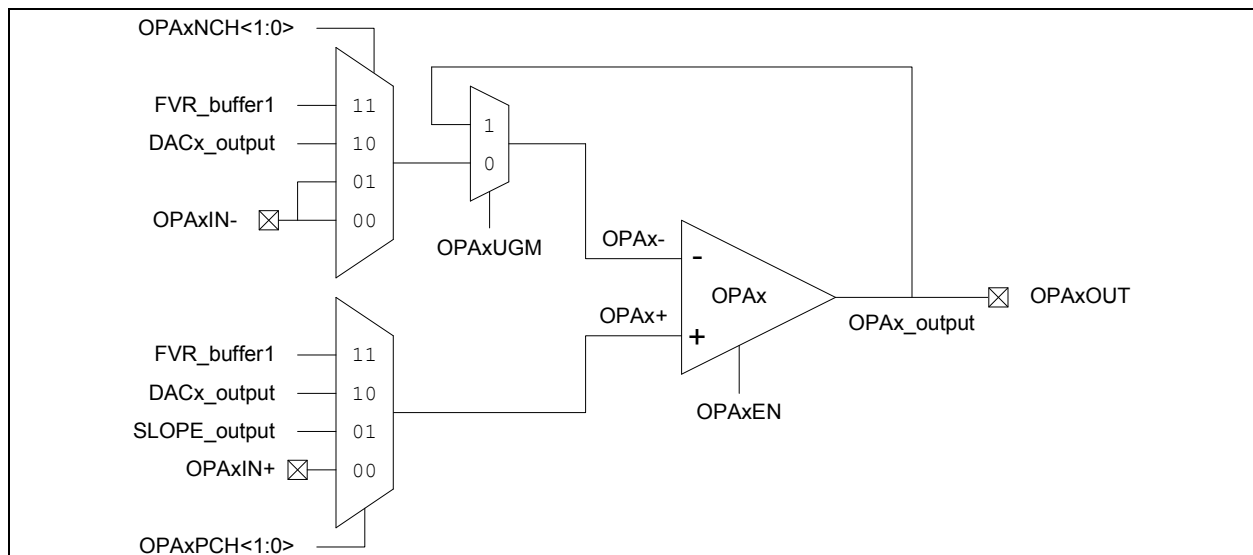
Common mode voltage range is the specified voltage range for the OPAX+ and OPAX- inputs, for which the OPA module will perform within its specifications. The OPA module is designed to operate with input voltages between VSS and VDD. Behavior for Common mode voltages greater than VDD or below VSS is not guaranteed.

Leakage current is a measure of the small source or sink currents on the OPAX+ and OPAX- inputs. To minimize the effect of leakage currents, the effective impedances connected to the OPAX+ and OPAX- inputs should be kept as small as possible and equal. Input offset voltage is a measure of the voltage difference between the OPAX+ and OPAX- inputs in a closed loop circuit with the OPA in its linear region. The offset voltage will appear as a DC offset in the output equal to the input offset voltage, multiplied by the gain of the circuit.

The input offset voltage is also affected by the Common mode voltage. The OPA is factory-calibrated to minimize the input offset voltage of the module. Open loop gain is the ratio of the output voltage to the differential input voltage (OPAX+) - (OPAX-). The gain is greatest at DC and falls off with frequency.

Gain Bandwidth Product or GBWP is the frequency at which the open loop gain falls off to 0 dB. The lower GBWP is optimized for systems requiring low-frequency response and low-power consumption.

**FIGURE 16-1: OPA MODULE BLOCK DIAGRAM**



# PIC16F753/HV753

## 16.4 Register Definitions: OPA Control

**REGISTER 16-1: OPAXCON0: OP AMP CONTROL REGISTER**

R/W-0/0	U-0	U-0	R/W-0/0	R/W-0/0	R/W-0/0	R/W-0/0	R/W-0/0
OPAxEN	—	—	OPAxUGM	OPAxNCH<1:0>		OPAxPCH<1:0>	
bit 7							bit 0

**Legend:**

R = Readable bit                      W = Writable bit                      U = Unimplemented bit, read as '0'  
 -n = Value at POR                      '1' = Bit is set                      '0' = Bit is cleared                      x = Bit is unknown

- bit 7            **OPAxEN:** OPAX Enable bit  
                   1 = OPAX is enabled  
                   0 = OPAX is disabled
- bit 6-5        **Unimplemented:** Read as '0'
- bit 4            **OPAxUGM:** OPAX Unity Gain Mode Enable bit  
                   1 = OPAX is in Unity gain mode  
                   0 = OPAX is not in Unity gain mode - operates as a three-terminal op amp
- bit 3-2        **OPAxNCH<1:0>:** OPAX Negative Input Source Selection bit  
                   11 = OPAX- connects to FVR\_buffer1  
                   10 = OPAX- connects to DAC1\_output  
                   0x = OPAX- connects to OPAXIN- pin
- bit 1-0        **OPAxPCH<1:0>:** OPAX Positive Input Source Selection bit  
                   11 = OPAX+ connects to FVR\_buffer1  
                   10 = OPAX+ connects to DAC1\_output  
                   01 = OPAX+ connects to SLOPE\_output  
                   00 = OPAX+ connects to OPAXIN+ pin

**TABLE 16-1: REGISTERS ASSOCIATED WITH THE OPA MODULE**

Name	Bit 7	Bit 6	Bit 5	Bit 4	Bit 3	Bit 2	Bit 1	Bit 0	Register on Page
OPA1CON0	OPA1EN	—	—	OPA1UGM	OPA1NCH<1:0>		OPA1PCH<1:0>		<a href="#">144</a>
TRISC	—	—	TRISC5	TRISC4	TRISC3	TRISC2	TRISC1	TRISC0	<a href="#">52</a>
ANSELC	—	—	—	—	ANSC3	ANSC2	ANSC1	ANSC0	<a href="#">54</a>

**Legend:** x = unknown, u = unchanged, - = unimplemented, read as '0'. Shaded cells are not used for the OPA module.



## 17.0 SLOPE COMPENSATION (SC) MODULE

The Slope Compensation (SC) module is designed to provide the necessary slope compensation for fixed frequency, continuous current, current mode switched power supplies. Slope compensation is a necessary feature of these power supplies because it prevents frequency instabilities at duty cycles greater than 50%.

## 17.1 Theory of Operation

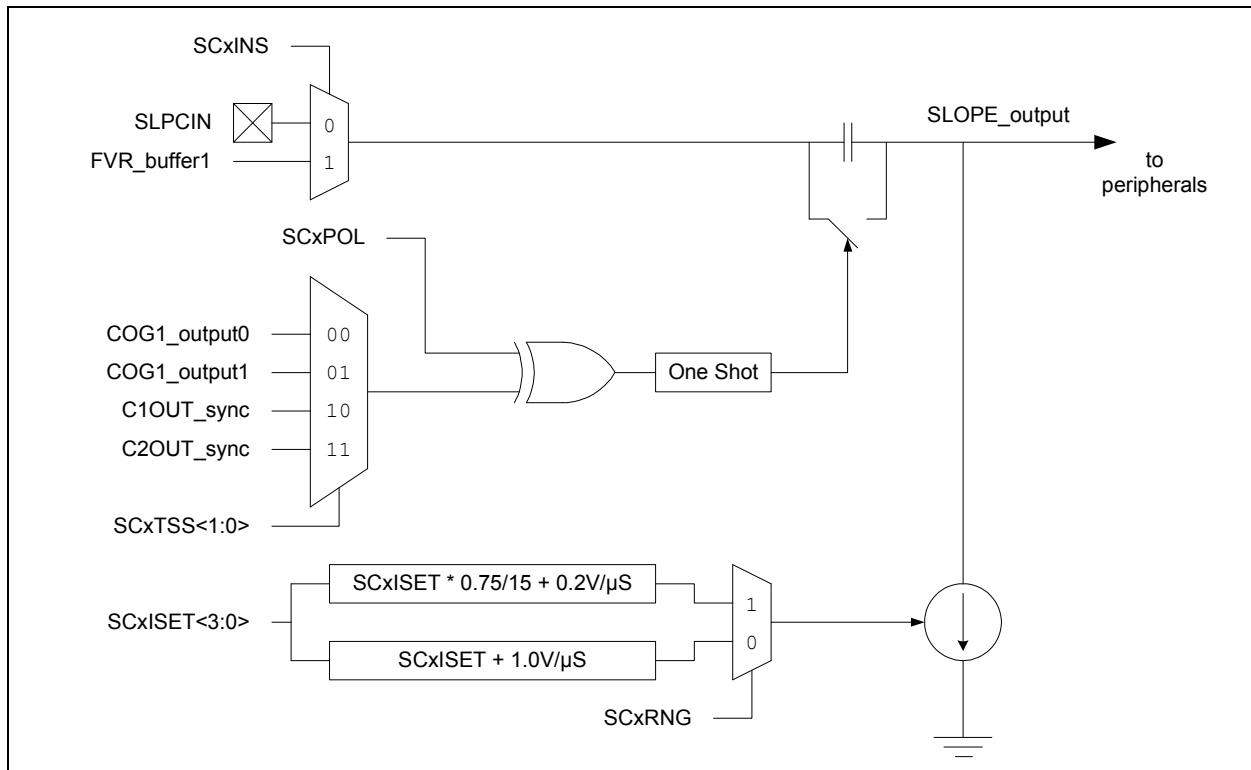
The SC module works by quickly discharging an internal capacitor at the beginning of each PWM period. A internal current sink charges this capacitor at a programmable rate. As the capacitor charges, the capacitor voltage is subtracted from the reference voltage, producing a linear voltage decay at the required rate. The current reference voltage can be supplied by either an I/O pin or by the buffered output of the FVR peripheral. The FVR module provides either a fixed voltage or a programmable DAC output. The Reset source can be derived from either COG output or the synchronized output of either comparator. Additionally, the Reset source can be inverted before triggering the Reset. The slope voltage can be sent to either comparator or the op amp.

The core of the SC module is:

- an on-chip capacitor in series with the voltage source,
- a shorting switch across the capacitor, and
- a calibrated current sink.

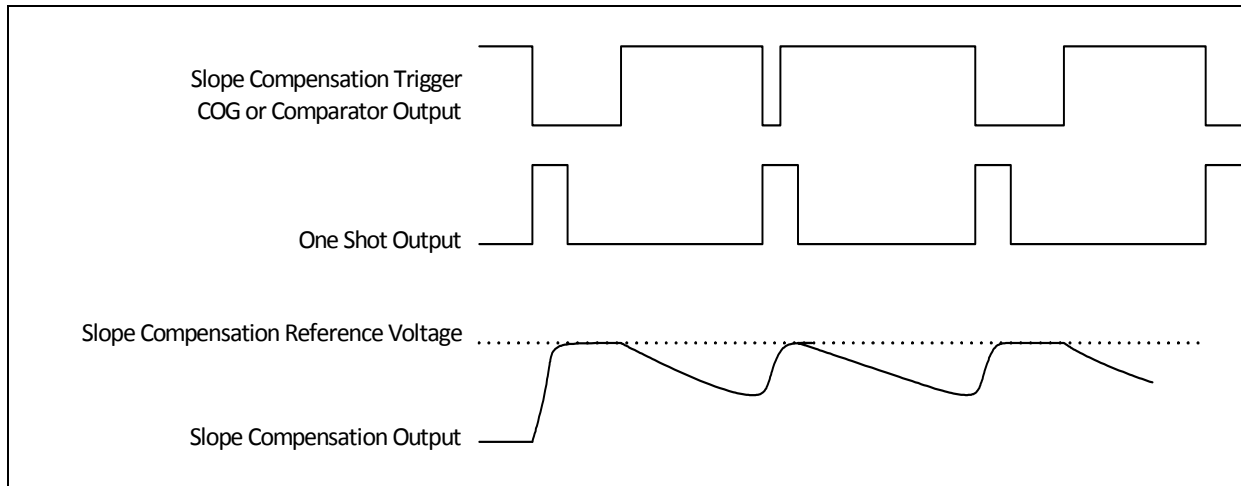
A one-shot pulse generator ensures that the switch is closed long enough to completely discharge the capacitor. This typically takes 50 nS.

**FIGURE 17-1: SIMPLIFIED SC MODULE BLOCK DIAGRAM**



# PIC16F753/HV753

FIGURE 17-2: SLOPE COMPENSATION TIMING DIAGRAM



## 17.2 Using the SC Module

The slope compensator input reference voltage should be set to the target circuit peak current sense voltage. The slope compensator output voltage starts at the input reference voltage and should fall at a rate less than half the target circuit current sense voltage rate of rise. Therefore, the compensator slope expressed as volts per  $\mu\text{s}$  can be computed as shown in Equation 17-2.

### EQUATION 17-1:

$$\frac{V}{\mu\text{s}} \geq \frac{\frac{V_{REF}}{2}}{PWM \text{ Period } (\mu\text{s})}$$

For example, when the circuit is using a  $1\Omega$  current sense resistor and the peak current is 1A, then the peak current expressed as a voltage ( $V_{REF}$ ) is 1V. If your power supply is running at 1 MHz, then the period is  $1\mu\text{s}$ . Therefore, the desired slope is:

### EQUATION 17-2:

$$\frac{\frac{V_{REF}}{2}}{PWM \text{ Period } (\mu\text{s})} = \frac{\frac{1}{2}}{1\mu\text{s}} = 0.5V/\mu\text{s}$$

**Note:** The setting for  $0.5V/\mu\text{s}$  is  $SCxISET<3:0> = 6$  and  $SCxRNG = 0$ .



# PIC16F753/HV753

## 17.7 Register Definitions: Slope Compensation Control

### REGISTER 17-1: SLPCCON0: SLOPE COMPENSATION CONTROL 0 REGISTER

R/W-0/0	U-0	U-0	R/W-0/0	R/W-0/0	R/W-0/0	U-0	R/W-0/0
SCxEN	—	—	SCxPOL	SCxTSS<1:0>		—	SCxINS
bit 7							bit 0

#### Legend:

R = Readable bit	W = Writable bit	U = Unimplemented bit, read as '0'
u = Bit is unchanged	x = Bit is unknown	-n/n = Value at POR and BOR/Value at all other Resets
'1' = Bit is set	'0' = Bit is cleared	q = value depends on configuration bits

- bit 7      **SCxEN:** Slope Compensation Enable bit  
 1 = Slope compensation is enabled  
 0 = Slope compensation is disabled
- bit 6-5    **Unimplemented:** Read as '0'
- bit 4      **SCxPOL:** Slope Compensation Input Polarity bit  
 1 = Signal is inverted polarity (active-low)  
 0 = Signal is normal polarity (active-high)
- bit 3-2    **SCxTSS<1:0>:** Slope Compensation Timing Select bits  
 11 = C2OUT\_sync  
 10 = C1OUT\_sync  
 01 = COG1\_output1  
 00 = COG1\_output0
- bit 1      **Unimplemented:** Read as '0'
- bit 0      **SCxINS:** Slope Compensation Input Select bit  
 1 = FVR\_buffer1 is selected  
 0 = SLPC1IN pin is selected

### REGISTER 17-2: SLPCCON1: SLOPE COMPENSATION CONTROL 1 REGISTER

U-0	U-0	U-0	R/W-0/0	R/W-0/0	R/W-0/0	R/W-0/0	R/W-0/0
—	—	—	SCxRNG	SCxISET<3:0>			
bit 7							bit 0

#### Legend:

R = Readable bit	W = Writable bit	U = Unimplemented bit, read as '0'
u = Bit is unchanged	x = Bit is unknown	-n/n = Value at POR and BOR/Value at all other Resets
'1' = Bit is set	'0' = Bit is cleared	q = value depends on configuration bits

- bit 7-5    **Unimplemented:** Read as '0'
- bit 4      **SCxRNG:** Slope Compensator Range bit  
 1 = Range setting is SCxISET \* 0.75/15 + 0.2V/μs  
 0 = Range setting is SCxISET + 1.0V/μs
- bit 3-0    **SCxISET<3:0>:** Slope Compensator Current Sink Set bits  
 xxxxxx = SC module Slope Selection

**TABLE 17-1: SLOPE COMPENSATOR CURRENT SETTINGS**

SC1ISET Value	Current Setting (uA)	Slope Value (V/us)	SC1ISET Value	Current Setting (uA)	Slope Value (V/us)
0h	2	0.2	10h	10	1.0
1h	2.5	0.25	11h	11	1.1
2h	3	0.3	12h	12	1.2
3h	3.5	0.35	13h	13	1.3
4h	4	0.4	14h	14	1.4
5h	4.5	0.45	15h	15	1.5
6h	5	0.5	16h	16	1.6
7h	5.5	0.55	17h	17	1.7
8h	6	0.6	18h	18	1.8
9h	6.5	0.65	19h	19	1.9
Ah	7	0.7	1Ah	20	2.0
Bh	7.5	0.75	1Bh	21	2.1
Ch	8	0.8	1Ch	22	2.2
Dh	8.5	0.85	1Dh	23	2.3
Eh	9	0.9	1Eh	24	2.4
Fh	9.5	0.95	1Fh	25	2.5

**TABLE 17-2: SUMMARY OF REGISTERS ASSOCIATED WITH THE SC MODULE**

Name	Bit 7	Bit 6	Bit 5	Bit 4	Bit 3	Bit 2	Bit 1	Bit 0	Register on Page
SLPCCON0	SC1EN	—	—	SC1POL	SC1TSS1	SC1TSS0	—	SC1INS	148
SLPCCON1	—	—	—	SC1RNG	SC1ISET<3:0>				148
PORTC	—	—	RC5	RC4	RC3	RC2	RC1	RC0	51
TRISC	—	—	TRISC5	TRISC4	TRISC3	TRISC2	TRISC1	TRISC0	52
ANSEL	—	—	—	—	ANSC3	ANSC2	ANSC1	ANSC0	54
WPUC	—	—	WPUC5	WPUC4	WPUC3	WPUC2	WPUC1	WPUC0	55

**Legend:** — = unimplemented, read as '0'. Shaded cells are unused by the slope compensation module.

**TABLE 17-3: SUMMARY OF CONFIGURATION WORD WITH THE SLOPE COMPENSATOR**

Name	Bits	Bit -/7	Bit -/6	Bit 13/5	Bit 12/4	Bit 11/3	Bit 10/2	Bit 9/1	Bit 8/0	Register on Page
CONFIG	13:8	—	—	DEBUG	CLKOUTEN	WRT<1:0>		BOREN<1:0>		162
	7:0	—	CP	MCLRE	PWRTE	WDTE	—	—	FOSC0	

**Legend:** — = unimplemented location, read as '0'. Shaded cells are not used by the slope compensation module.

# PIC16F753/HV753

---

NOTES:

## 18.0 INSTRUCTION SET SUMMARY

The PIC16F753/HV753 instruction set is highly orthogonal and is comprised of three basic categories:

- **Byte-oriented** operations
- **Bit-oriented** operations
- **Literal and control** operations

Each PIC16 instruction is a 14-bit word divided into an **opcode**, which specifies the instruction type and one or more **operands**, which further specify the operation of the instruction. The formats for each of the categories is presented in Figure 18-1, while the various opcode fields are summarized in Table 18-1.

Table 18-2 lists the instructions recognized by the MPASM™ assembler.

For **byte-oriented** instructions, 'f' represents a file register designator and 'd' represents a destination designator. The file register designator specifies which file register is to be used by the instruction.

The destination designator specifies where the result of the operation is to be placed. If 'd' is zero, the result is placed in the W register. If 'd' is one, the result is placed in the file register specified in the instruction.

For **bit-oriented** instructions, 'b' represents a bit field designator, which selects the bit affected by the operation, while 'f' represents the address of the file in which the bit is located.

For **literal and control** operations, 'k' represents an 8-bit or 11-bit constant, or literal value.

One instruction cycle consists of four oscillator periods; for an oscillator frequency of 4 MHz, this gives a normal instruction execution time of 1 μs. All instructions are executed within a single instruction cycle, unless a conditional test is true, or the program counter is changed as a result of an instruction. When this occurs, the execution takes two instruction cycles, with the second cycle executed as a **NOOP**.

All instruction examples use the format '0xhh' to represent a hexadecimal number, where 'h' signifies a hexadecimal digit.

### 18.1 Read-Modify-Write Operations

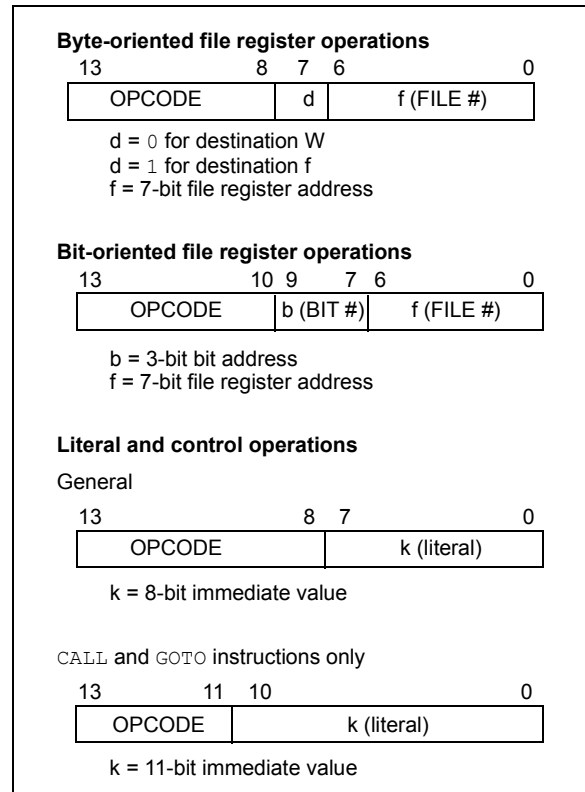
Any instruction that specifies a file register as part of the instruction performs a Read-Modify-Write (RMW) operation. The register is read, the data is modified, and the result is stored according to either the instruction or the destination designator 'd'. A read operation is performed on a register even if the instruction writes to that register.

For example, a `CLRF PORTA` instruction will read PORTA, clear all the data bits, then write the result back to PORTA. This example would have the unintended consequence of clearing the condition that set the IOCIF flag.

TABLE 18-1: OPCODE FIELD DESCRIPTIONS

Field	Description
f	Register file address (0x00 to 0x7F)
W	Working register (accumulator)
b	Bit address within an 8-bit file register
k	Literal field, constant data or label
x	Don't care location (= 0 or 1). The assembler will generate code with x = 0. It is the recommended form of use for compatibility with all Microchip software tools.
d	Destination select; d = 0: store result in W, d = 1: store result in file register f. Default is d = 1.
PC	Program Counter
$\overline{TO}$	Time-out bit
C	Carry bit
DC	Digit carry bit
Z	Zero bit
$\overline{PD}$	Power-down bit

FIGURE 18-1: GENERAL FORMAT FOR INSTRUCTIONS



# PIC16F753/HV753

**TABLE 18-2: PIC16F753/HV753 INSTRUCTION SET**

Mnemonic, Operands	Description	Cycles	14-Bit Opcode		Status Affected	Notes	
			MSb	LSb			
<b>BYTE-ORIENTED FILE REGISTER OPERATIONS</b>							
ADDWF	f, d	Add W and f	1	00	0111 dfff ffff	C, DC, Z	1, 2
ANDWF	f, d	AND W with f	1	00	0101 dfff ffff	Z	1, 2
CLRF	f	Clear f	1	00	0001 1fff ffff	Z	2
CLRWF	–	Clear W	1	00	0001 0xxx xxxx	Z	
COMF	f, d	Complement f	1	00	1001 dfff ffff	Z	1, 2
DECF	f, d	Decrement f	1	00	0011 dfff ffff	Z	1, 2
DECFSZ	f, d	Decrement f, Skip if 0	1(2)	00	1011 dfff ffff		1, 2, 3
INCF	f, d	Increment f	1	00	1010 dfff ffff	Z	1, 2
INCFSZ	f, d	Increment f, Skip if 0	1(2)	00	1111 dfff ffff		1, 2, 3
IORWF	f, d	Inclusive OR W with f	1	00	0100 dfff ffff	Z	1, 2
MOVF	f, d	Move f	1	00	1000 dfff ffff	Z	1, 2
MOVWF	f	Move W to f	1	00	0000 1fff ffff		
NOP	–	No Operation	1	00	0000 0xx0 0000		
RLF	f, d	Rotate Left f through Carry	1	00	1101 dfff ffff	C	1, 2
RRF	f, d	Rotate Right f through Carry	1	00	1100 dfff ffff	C	1, 2
SUBWF	f, d	Subtract W from f	1	00	0010 dfff ffff	C, DC, Z	1, 2
SWAPF	f, d	Swap nibbles in f	1	00	1110 dfff ffff		1, 2
XORWF	f, d	Exclusive OR W with f	1	00	0110 dfff ffff	Z	1, 2
<b>BIT-ORIENTED FILE REGISTER OPERATIONS</b>							
BCF	f, b	Bit Clear f	1	01	00bb bfff ffff		1, 2
BSF	f, b	Bit Set f	1	01	01bb bfff ffff		1, 2
BTFSC	f, b	Bit Test f, Skip if Clear	1(2)	01	10bb bfff ffff		3
BTFSS	f, b	Bit Test f, Skip if Set	1(2)	01	11bb bfff ffff		3
<b>LITERAL AND CONTROL OPERATIONS</b>							
ADDLW	k	Add literal and W	1	11	111x kkkk kkkk	C, DC, Z	
ANDLW	k	AND literal with W	1	11	1001 kkkk kkkk	Z	
CALL	k	Call Subroutine	2	10	0kkk kkkk kkkk		
CLRWDTC	–	Clear Watchdog Timer	1	00	0000 0110 0100	$\overline{TO}, \overline{PD}$	
GOTO	k	Go to address	2	10	1kkk kkkk kkkk		
IORLW	k	Inclusive OR literal with W	1	11	1000 kkkk kkkk	Z	
MOVLW	k	Move literal to W	1	11	00xx kkkk kkkk		
RETFIE	–	Return from interrupt	2	00	0000 0000 1001		
RETLW	k	Return with literal in W	2	11	01xx kkkk kkkk		
RETURN	–	Return from Subroutine	2	00	0000 0000 1000		
SLEEP	–	Go into Standby mode	1	00	0000 0110 0011	$\overline{TO}, \overline{PD}$	
SUBLW	k	Subtract W from literal	1	11	110x kkkk kkkk	C, DC, Z	
XORLW	k	Exclusive OR literal with W	1	11	1010 kkkk kkkk	Z	

- Note 1:** When an I/O register is modified as a function of itself (e.g., `MOVF PORTA, 1`), the value used will be that value present on the pins themselves. For example, if the data latch is '1' for a pin configured as input and is driven low by an external device, the data will be written back with a '0'.
- 2:** If this instruction is executed on the TMR0 register (and where applicable, d = 1), the prescaler will be cleared if assigned to the Timer0 module.
- 3:** If the Program Counter (PC) is modified, or a conditional test is true, the instruction requires two cycles. The second cycle is executed as a `NOP`.



## 18.2 Instruction Descriptions

### **ADDLW**      **Add literal and W**

**Syntax:**            `[label] ADDLW k`

**Operands:**         $0 \leq k \leq 255$

**Operation:**         $(W) + k \rightarrow (W)$

**Status Affected:** C, DC, Z

**Description:**      The contents of the W register are added to the 8-bit literal 'k' and the result is placed in the W register.

### **BCF**            **Bit Clear f**

**Syntax:**            `[label] BCF f,b`

**Operands:**         $0 \leq f \leq 127$   
 $0 \leq b \leq 7$

**Operation:**         $0 \rightarrow (f<b>)$

**Status Affected:** None

**Description:**      Bit 'b' in register 'f' is cleared.

### **ADDWF**        **Add W and f**

**Syntax:**            `[label] ADDWF f,d`

**Operands:**         $0 \leq f \leq 127$   
 $d \in [0,1]$

**Operation:**         $(W) + (f) \rightarrow (\text{destination})$

**Status Affected:** C, DC, Z

**Description:**      Add the contents of the W register with register 'f'. If 'd' is '0', the result is stored in the W register. If 'd' is '1', the result is stored back in register 'f'.

### **BSF**            **Bit Set f**

**Syntax:**            `[label] BSF f,b`

**Operands:**         $0 \leq f \leq 127$   
 $0 \leq b \leq 7$

**Operation:**         $1 \rightarrow (f<b>)$

**Status Affected:** None

**Description:**      Bit 'b' in register 'f' is set.

### **ANDLW**        **AND literal with W**

**Syntax:**            `[label] ANDLW k`

**Operands:**         $0 \leq k \leq 255$

**Operation:**         $(W) .\text{AND.} (k) \rightarrow (W)$

**Status Affected:** Z

**Description:**      The contents of W register are AND'ed with the 8-bit literal 'k'. The result is placed in the W register.

### **BTFSC**        **Bit Test f, Skip if Clear**

**Syntax:**            `[label] BTFSC f,b`

**Operands:**         $0 \leq f \leq 127$   
 $0 \leq b \leq 7$

**Operation:**        skip if  $(f<b>) = 0$

**Status Affected:** None

**Description:**      If bit 'b' in register 'f' is '1', the next instruction is executed.  
If bit 'b' in register 'f' is '0', the next instruction is discarded, and a NOP is executed instead, making this a two-cycle instruction.

### **ANDWF**        **AND W with f**

**Syntax:**            `[label] ANDWF f,d`

**Operands:**         $0 \leq f \leq 127$   
 $d \in [0,1]$

**Operation:**         $(W) .\text{AND.} (f) \rightarrow (\text{destination})$

**Status Affected:** Z

**Description:**      AND the W register with register 'f'. If 'd' is '0', the result is stored in the W register. If 'd' is '1', the result is stored back in register 'f'.

# PIC16F753/HV753

---

## **BTFS** Bit Test f, Skip if Set

---

Syntax: [ *label* ] BTFS f,b  
Operands:  $0 \leq f \leq 127$   
 $0 \leq b < 7$   
Operation: skip if (f<b>) = 1  
Status Affected: None  
Description: If bit 'b' in register 'f' is '0', the next instruction is executed.  
If bit 'b' is '1', then the next instruction is discarded and a NOP is executed instead, making this a two-cycle instruction.

## **CLRWD** Clear Watchdog Timer

---

Syntax: [ *label* ] CLRWD  
Operands: None  
Operation: 00h → WDT  
0 → WDT prescaler,  
1 →  $\overline{TO}$   
1 →  $\overline{PD}$   
Status Affected:  $\overline{TO}$ ,  $\overline{PD}$   
Description: CLRWD instruction resets the Watchdog Timer. It also resets the prescaler of the WDT.  
Status bits  $\overline{TO}$  and  $\overline{PD}$  are set.

## **CALL** Call Subroutine

---

Syntax: [ *label* ] CALL k  
Operands:  $0 \leq k \leq 2047$   
Operation: (PC)+1 → TOS,  
k → PC<10:0>,  
(PCLATH<4:3>) → PC<12:11>  
Status Affected: None  
Description: Call Subroutine. First, return address (PC + 1) is pushed onto the stack. The 11-bit immediate address is loaded into PC bits <10:0>. The upper bits of the PC are loaded from PCLATH. CALL is a two-cycle instruction.

## **COMF** Complement f

---

Syntax: [ *label* ] COMF f,d  
Operands:  $0 \leq f \leq 127$   
d ∈ [0,1]  
Operation: ( $\bar{f}$ ) → (destination)  
Status Affected: Z  
Description: The contents of register 'f' are complemented. If 'd' is '0', the result is stored in W. If 'd' is '1', the result is stored back in register 'f'.

## **CLRF** Clear f

---

Syntax: [ *label* ] CLRF f  
Operands:  $0 \leq f \leq 127$   
Operation: 00h → (f)  
1 → Z  
Status Affected: Z  
Description: The contents of register 'f' are cleared and the Z bit is set.

## **DECF** Decrement f

---

Syntax: [ *label* ] DECF f,d  
Operands:  $0 \leq f \leq 127$   
d ∈ [0,1]  
Operation: (f) - 1 → (destination)  
Status Affected: Z  
Description: Decrement register 'f'. If 'd' is '0', the result is stored in the W register. If 'd' is '1', the result is stored back in register 'f'.

## **CLRW** Clear W

---

Syntax: [ *label* ] CLRW  
Operands: None  
Operation: 00h → (W)  
1 → Z  
Status Affected: Z  
Description: W register is cleared. Zero bit (Z) is set.

## **DECFSZ      Decrement f, Skip if 0**

**Syntax:**            *[label]* DECFSZ f,d

**Operands:**         $0 \leq f \leq 127$   
 $d \in [0,1]$

**Operation:**         $(f) - 1 \rightarrow (\text{destination});$   
skip if result = 0

**Status Affected:** None

**Description:**     The contents of register 'f' are decremented. If 'd' is '0', the result is placed in the W register. If 'd' is '1', the result is placed back in register 'f'.  
If the result is '1', the next instruction is executed. If the result is '0', then a NOP is executed instead, making it a two-cycle instruction.

## **INCFSZ      Increment f, Skip if 0**

**Syntax:**            *[label]* INCFSZ f,d

**Operands:**         $0 \leq f \leq 127$   
 $d \in [0,1]$

**Operation:**         $(f) + 1 \rightarrow (\text{destination});$   
skip if result = 0

**Status Affected:** None

**Description:**     The contents of register 'f' are incremented. If 'd' is '0', the result is placed in the W register. If 'd' is '1', the result is placed back in register 'f'.  
If the result is '1', the next instruction is executed. If the result is '0', a NOP is executed instead, making it a two-cycle instruction.

## **GOTO        Unconditional Branch**

**Syntax:**            *[label]* GOTO k

**Operands:**         $0 \leq k \leq 2047$

**Operation:**         $k \rightarrow \text{PC}\langle 10:0 \rangle$   
 $\text{PCLATH}\langle 4:3 \rangle \rightarrow \text{PC}\langle 12:11 \rangle$

**Status Affected:** None

**Description:**     GOTO is an unconditional branch. The 11-bit immediate value is loaded into PC bits  $\langle 10:0 \rangle$ . The upper bits of PC are loaded from PCLATH $\langle 4:3 \rangle$ . GOTO is a two-cycle instruction.

## **IORLW      Inclusive OR literal with W**

**Syntax:**            *[label]* IORLW k

**Operands:**         $0 \leq k \leq 255$

**Operation:**         $(W) .OR. k \rightarrow (W)$

**Status Affected:** Z

**Description:**     The contents of the W register are OR'ed with the 8-bit literal 'k'. The result is placed in the W register.

## **INCF        Increment f**

**Syntax:**            *[label]* INCF f,d

**Operands:**         $0 \leq f \leq 127$   
 $d \in [0,1]$

**Operation:**         $(f) + 1 \rightarrow (\text{destination})$

**Status Affected:** Z

**Description:**     The contents of register 'f' are incremented. If 'd' is '0', the result is placed in the W register. If 'd' is '1', the result is placed back in register 'f'.

## **IORWF      Inclusive OR W with f**

**Syntax:**            *[label]* IORWF f,d

**Operands:**         $0 \leq f \leq 127$   
 $d \in [0,1]$

**Operation:**         $(W) .OR. (f) \rightarrow (\text{destination})$

**Status Affected:** Z

**Description:**     Inclusive OR the W register with register 'f'. If 'd' is '0', the result is placed in the W register. If 'd' is '1', the result is placed back in register 'f'.

# PIC16F753/HV753

---

<b>MOVF</b>	<b>Move f</b>
Syntax:	[ <i>label</i> ] MOVF f,d
Operands:	$0 \leq f \leq 127$ $d \in [0,1]$
Operation:	(f) → (dest)
Status Affected:	Z
Description:	The contents of register 'f' is moved to a destination dependent upon the status of 'd'. If d = 0, destination is W register. If d = 1, the destination is file register 'f' itself. d = 1 is useful to test a file register since Status flag Z is affected.
Words:	1
Cycles:	1
Example:	<pre>MOVF    FSR, 0</pre> <p>After Instruction</p> <pre>W = value in FSR register Z = 1</pre>

<b>MOVLW</b>	<b>Move literal to W</b>
Syntax:	[ <i>label</i> ] MOVLW k
Operands:	$0 \leq k \leq 255$
Operation:	$k \rightarrow (W)$
Status Affected:	None
Description:	The 8-bit literal 'k' is loaded into W register. The "don't cares" will assemble as '0's.
Words:	1
Cycles:	1
Example:	<pre>MOVLW  0x5A</pre> <p>After Instruction</p> <pre>W = 0x5A</pre>

<b>MOVWF</b>	<b>Move W to f</b>
Syntax:	[ <i>label</i> ] MOVWF f
Operands:	$0 \leq f \leq 127$
Operation:	(W) → (f)
Status Affected:	None
Description:	Move data from W register to register 'f'.
Words:	1
Cycles:	1
Example:	<pre>MOVWF  OPTION F</pre> <p>Before Instruction</p> <pre>OPTION = 0xFF W       = 0x4F</pre> <p>After Instruction</p> <pre>OPTION = 0x4F W       = 0x4F</pre>

<b>NOP</b>	<b>No Operation</b>
Syntax:	[ <i>label</i> ] NOP
Operands:	None
Operation:	No operation
Status Affected:	None
Description:	No operation.
Words:	1
Cycles:	1
Example:	<pre>NOP</pre>

<b>RETFIE</b>	<b>Return from Interrupt</b>
Syntax:	[ <i>label</i> ] RETFIE
Operands:	None
Operation:	TOS → PC, 1 → GIE
Status Affected:	None
Description:	Return from Interrupt. Stack is POPed and Top-of-Stack (TOS) is loaded in the PC. Interrupts are enabled by setting Global Interrupt Enable bit, GIE (INTCON<7>). This is a two-cycle instruction.
Words:	1
Cycles:	2
<u>Example:</u>	<pre> RETFIE After Interrupt     PC = TOS     GIE = 1         </pre>

<b>RETLW</b>	<b>Return with literal in W</b>
Syntax:	[ <i>label</i> ] RETLW k
Operands:	0 ≤ k ≤ 255
Operation:	k → (W); TOS → PC
Status Affected:	None
Description:	The W register is loaded with the 8-bit literal 'k'. The program counter is loaded from the top of the stack (the return address). This is a two-cycle instruction.
Words:	1
Cycles:	2
<u>Example:</u>	<pre> CALL TABLE;W contains                     ;table offset                     ;value  GOTO DONE TABLE     •     •     ADDWF PC    ;W = offset     RETLW k1    ;Begin table     RETLW k2    ;     •     •     RETLW kn    ;End of table  DONE  Before Instruction     W = 0x07 After Instruction     W = value of k8         </pre>

<b>RETURN</b>	<b>Return from Subroutine</b>
Syntax:	[ <i>label</i> ] RETURN
Operands:	None
Operation:	TOS → PC
Status Affected:	None
Description:	Return from subroutine. The stack is POPed and the top of the stack (TOS) is loaded into the program counter. This is a two-cycle instruction.

# PIC16F753/HV753

## RLF Rotate Left f through Carry

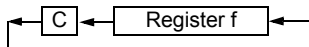
**Syntax:** `[label] RLF f,d`

**Operands:**  $0 \leq f \leq 127$   
 $d \in [0,1]$

**Operation:** See description below

**Status Affected:** C

**Description:** The contents of register 'f' are rotated 1 bit to the left through the Carry flag. If 'd' is '0', the result is placed in the W register. If 'd' is '1', the result is stored back in register 'f'.



**Words:** 1

**Cycles:** 1

**Example:**

```

RLF    REG1,0

Before Instruction
REG1   = 1110 0110
C      = 0

After Instruction
REG1   = 1110 0110
W      = 1100 1100
C      = 1
    
```

## SLEEP Enter Sleep mode

**Syntax:** `[label] SLEEP`

**Operands:** None

**Operation:** 00h → WDT,  
 0 → WDT prescaler,  
 1 →  $\overline{TO}$ ,  
 0 →  $\overline{PD}$

**Status Affected:**  $\overline{TO}$ ,  $\overline{PD}$

**Description:** The power-down Status bit,  $\overline{PD}$  is cleared. Time-out Status bit,  $\overline{TO}$  is set. Watchdog Timer and its prescaler are cleared. The processor is put into Sleep mode with the oscillator stopped.

## RRF Rotate Right f through Carry

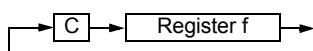
**Syntax:** `[label] RRF f,d`

**Operands:**  $0 \leq f \leq 127$   
 $d \in [0,1]$

**Operation:** See description below

**Status Affected:** C

**Description:** The contents of register 'f' are rotated 1 bit to the right through the Carry flag. If 'd' is '0', the result is placed in the W register. If 'd' is '1', the result is placed back in register 'f'.



## SUBLW Subtract W from literal

**Syntax:** `[label] SUBLW k`

**Operands:**  $0 \leq k \leq 255$

**Operation:**  $k - (W) \rightarrow (W)$

**Status Affected:** C, DC, Z

**Description:** The W register is subtracted (2's complement method) from the 8-bit literal 'k'. The result is placed in the W register.

Result	Condition
C = 0	$W > k$
C = 1	$W \leq k$
DC = 0	$W\langle 3:0 \rangle > k\langle 3:0 \rangle$
DC = 1	$W\langle 3:0 \rangle \leq k\langle 3:0 \rangle$

## **SUBWF**      **Subtract W from f**

Syntax:      [*label*] SUBWF f,d

Operands:     $0 \leq f \leq 127$   
 $d \in [0,1]$

Operation:     $(f) - (W) \rightarrow (\text{destination})$

Status Affected: C, DC, Z

Description:   Subtract (2's complement method) W register from register 'f'. If 'd' is '0', the result is stored in the W register. If 'd' is '1', the result is stored back in register 'f'.

C = 0	$W > f$
C = 1	$W \leq f$
DC = 0	$W\langle 3:0 \rangle > f\langle 3:0 \rangle$
DC = 1	$W\langle 3:0 \rangle \leq f\langle 3:0 \rangle$

## **XORWF**      **Exclusive OR W with f**

Syntax:      [*label*] XORWF f,d

Operands:     $0 \leq f \leq 127$   
 $d \in [0,1]$

Operation:     $(W) .XOR. (f) \rightarrow (\text{destination})$

Status Affected: Z

Description:   Exclusive OR the contents of the W register with register 'f'. If 'd' is '0', the result is stored in the W register. If 'd' is '1', the result is stored back in register 'f'.

## **SWAPF**      **Swap Nibbles in f**

Syntax:      [*label*] SWAPF f,d

Operands:     $0 \leq f \leq 127$   
 $d \in [0,1]$

Operation:     $(f\langle 3:0 \rangle) \rightarrow (\text{destination}\langle 7:4 \rangle)$ ,  
 $(f\langle 7:4 \rangle) \rightarrow (\text{destination}\langle 3:0 \rangle)$

Status Affected: None

Description:   The upper and lower nibbles of register 'f' are exchanged. If 'd' is '0', the result is placed in the W register. If 'd' is '1', the result is placed in register 'f'.

## **XORLW**      **Exclusive OR literal with W**

Syntax:      [*label*] XORLW k

Operands:     $0 \leq k \leq 255$

Operation:     $(W) .XOR. k \rightarrow (W)$

Status Affected: Z

Description:   The contents of the W register are XOR'ed with the 8-bit literal 'k'. The result is placed in the W register.

# PIC16F753/HV753

---

NOTES:



## 19.0 SPECIAL FEATURES OF THE CPU

The PIC16F753/HV753 has a host of features intended to maximize system reliability, minimize cost through elimination of external components, provide power-saving features and offer code protection.

These features are:

- Reset
  - Power-on Reset (POR)
  - Power-up Timer (PWRT)
  - Brown-out Reset (BOR)
- Interrupts
- Watchdog Timer (WDT)
- Oscillator selection
- Sleep
- Code protection
- ID Locations
- In-Circuit Serial Programming™

The Power-up Timer (PWRT), which provides a fixed delay of 64 ms (nominal) on power-up only, is designed to keep the part in Reset while the power supply stabilizes. There is also circuitry to reset the device if a brown-out occurs, which can use the Power-up Timer to provide at least a 64 ms Reset. With these functions-on-chip, most applications need no external Reset circuitry.

The Sleep mode is designed to offer a very low-current Power-Down mode. The user can wake-up from Sleep through:

- External Reset
- Watchdog Timer Wake-up
- An interrupt

Oscillator selection options are available to allow the part to fit the application. The INTOSC options save system cost, while the External Clock (EC) option provides a means for specific frequency and accurate clock sources. Configuration bits are used to select various options (see [Register 19-1](#)).

## 19.1 Configuration Bits

The Configuration bits can be programmed (read as '0'), or left unprogrammed (read as '1') to select various device configurations as shown in [Register 19-1](#). These bits are mapped in program memory location 2007h.

**Note:** Address 2007h is beyond the user program memory space. It belongs to the special configuration memory space (2000h-3FFFh), which can be accessed only during programming. See the "*PIC16F753/HV753 Flash Memory Programming Specification*" (DS41686) for more information.

# PIC16F753/HV753

## REGISTER 19-1: CONFIGURATION WORD

R/P-1	R/P-1	R/P-1	R/P-1	R/P-1	R/P-1
DEBUG	CLKOUTEN	WRT<1:0>		BOREN<1:0>	
bit 13					bit 8

U-1	R/P-1	R/P-1	R/P-1	R/P-1	U-1	U-1	R/P-1
—	CP	MCLRE	PWRTE	WDTE	—	—	FOSC0
bit 7							bit 0

### Legend:

R = Readable bit      P = Programmable bit      U = Unimplemented bit, read as '1'  
 '0' = Bit is cleared      '1' = Bit is set      -n = Value when blank or after Bulk Erase

- bit 13      **DEBUG:** Debug Mode Enable bit<sup>(2)</sup>  
 1 = Background debugger is disabled  
 0 = Background debugger is enabled
- bit 12      **CLKOUTEN:** Clock Out Enable bit  
 1 = Clock out function disabled. CLKOUT pin acts as I/O pin  
 0 = General purpose I/O disabled. CLKOUT pin acts as CLKOUT
- bit 11-10      **WRT<1:0>:** Flash Program Memory Self Write Enable bit  
 11 = Write protection off  
 10 = 000h to FFh write-protected, 100h to 3FFh may be modified by PMCON1 control  
 01 = 000h to 1FFh write-protected, 200h to 3FFh may be modified by PMCON1 control  
 00 = 000h to 3FFh write-protected, entire program is write-protected
- bit 8-9      **BOREN<1:0>:** Brown-out Reset Enable bits  
 11 = BOR enabled  
 10 = BOR enabled during operation and disabled in Sleep  
 0x = BOR disabled
- bit 7      **Unimplemented:** Read as '1'
- bit 6      **CP:** Code Protection bit  
 1 = Program memory code protection is disabled  
 0 = Program memory code protection is enabled
- bit 5      **MCLRE:** MCLR/VPP Pin Function Select bit  
 1 = MCLR pin is MCLR function and weak internal pull-up is enabled  
 0 = MCLR pin is input function, MCLR function is internally disabled
- bit 4      **PWRTE:** Power-up Timer Enable bit<sup>(1)</sup>  
 1 = PWRT disabled  
 0 = PWRT enabled
- bit 3      **WDTE:** Watchdog Timer Enable bit  
 1 = WDT enabled  
 0 = WDT disabled
- bit 2-1      **Unimplemented:** Read as '1'
- bit 0      **FOSC:** Oscillator Selection bits  
 1 = EC oscillator selected: CLKIN on RA5/CLKIN  
 0 = Internal oscillator: I/O function on RA5/CLKIN

**Note 1:** Enabling Brown-out Reset does not automatically enable Power-up Timer.

**Note 2:** The Configuration bit is managed automatically by the device development tools. The user should not attempt to manually write this bit location. However, the user should ensure that this location has been programmed to a '1' and the device checksum is correct for proper operation of production software.

## 19.2 Calibration Bits

The 8 MHz internal oscillator is factory calibrated. These calibration values are stored in fuses located in the Calibration Word (2008h). The Calibration Word is not erased when using the specified bulk erase sequence in the “PIC16F753/HV753 Flash Memory Programming Specification” (DS41686) and thus, does not require reprogramming.

## 19.3 Reset

The PIC16F753/HV753 device differentiates between various kinds of Reset:

- Power-on Reset (POR)
- WDT Reset during normal operation
- WDT Reset during Sleep
- MCLR Reset during normal operation
- MCLR Reset during Sleep
- Brown-out Reset (BOR)

Some registers are not affected in any Reset condition; their status is unknown on POR and unchanged in any other Reset. Most other registers are reset to a “Reset state” on:

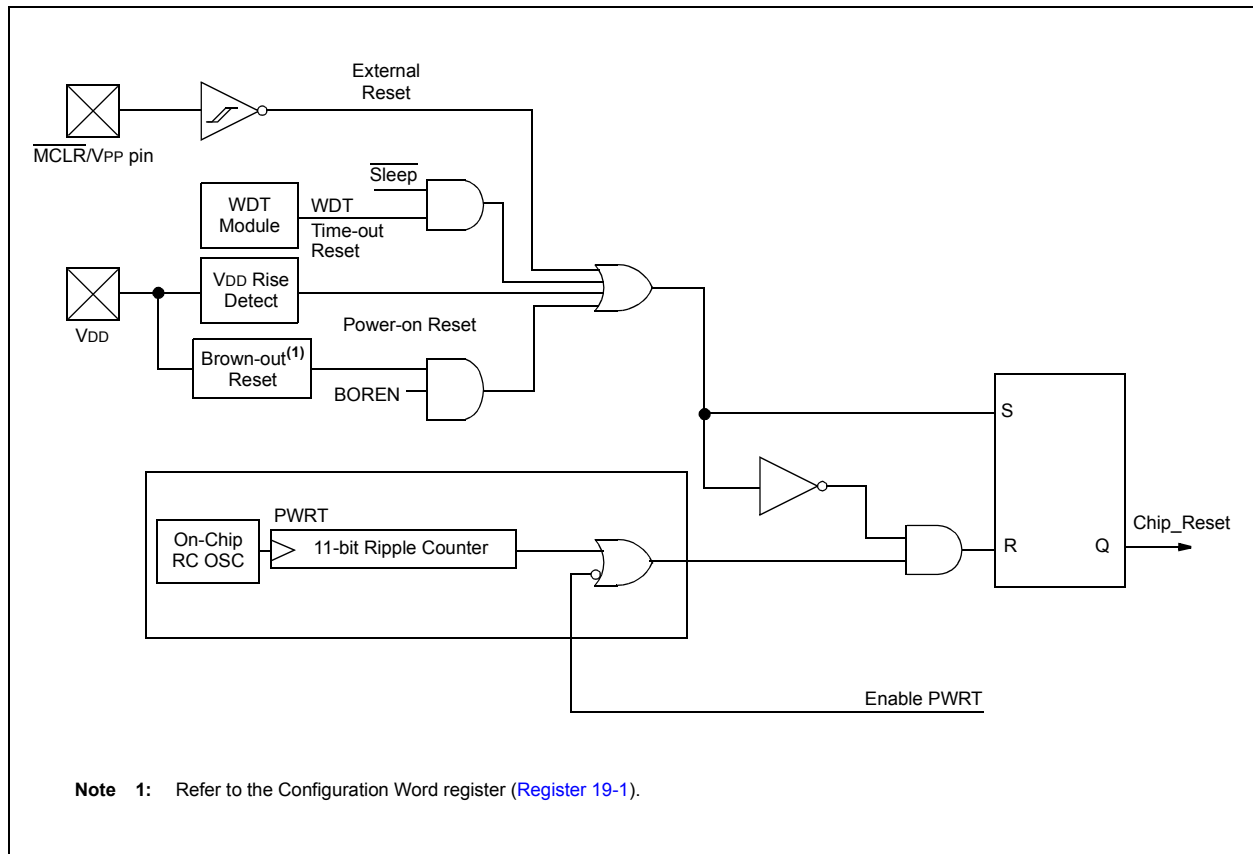
- Power-on Reset
- MCLR Reset
- MCLR Reset during Sleep
- WDT Reset
- Brown-out Reset (BOR)

WDT wake-up does not cause register Resets in the same manner as a WDT Reset since wake-up is viewed as the resumption of normal operation.  $\overline{TO}$  and  $\overline{PD}$  bits are set or cleared differently in different Reset situations, as indicated in Table 19-2. Software can use these bits to determine the nature of the Reset. See Table 19-4 for a full description of Reset states of all registers.

A simplified block diagram of the On-Chip Reset Circuit is shown in Figure 19-1.

The MCLR Reset path has a noise filter to detect and ignore small pulses. See Section 22.0 “Electrical Specifications” for pulse-width specifications.

**FIGURE 19-1: SIMPLIFIED BLOCK DIAGRAM OF ON-CHIP RESET CIRCUIT**



**Note 1:** Refer to the Configuration Word register (Register 19-1).

# PIC16F753/HV753

**TABLE 19-1: TIME-OUT IN VARIOUS SITUATIONS**

Oscillator Configuration	Power-up		Brown-out Reset		Wake-up from Sleep
	$\overline{PWRTE} = 0$	$\overline{PWRTE} = 1$	$\overline{PWRTE} = 0$	$\overline{PWRTE} = 1$	
EC, INTOSC	TPWRT	—	TPWRT	—	—

**TABLE 19-2: STATUS/PCON BITS AND THEIR SIGNIFICANCE**

$\overline{POR}$	$\overline{BOR}$	$\overline{TO}$	$\overline{PD}$	Condition
0	x	1	1	Power-on Reset
u	0	1	1	Brown-out Reset
u	u	0	u	WDT Reset
u	u	0	0	WDT Wake-up
u	u	u	u	$\overline{MCLR}$ Reset during normal operation
u	u	1	0	$\overline{MCLR}$ Reset during Sleep

**Legend:** u = unchanged, x = unknown

### 19.3.1 POWER-ON RESET (POR)

The on-chip POR circuit holds the chip in Reset until VDD has reached a high enough level for proper operation. To take advantage of the POR, simply connect the MCLR pin through a resistor to VDD. This will eliminate external RC components usually needed to create Power-on Reset. A maximum rise time for VDD is required. See [Section 22.0 “Electrical Specifications”](#) for details. If the BOR is enabled, the maximum rise time specification does not apply. The BOR circuitry will keep the device in Reset until VDD reaches VBOR (see [Section 19.3.4 “Brown-out Reset \(BOR\)”](#)).

**Note:** The POR circuit does not produce an internal Reset when VDD declines. To re-enable the POR, VDD must reach Vss for a minimum of 100 μs.

When the device starts normal operation (exits the Reset condition), device operating parameters (i.e., voltage, frequency, temperature, etc.) must be met to ensure proper operation. If these conditions are not met, the device must be held in Reset until the operating conditions are met.

For additional information, refer to Application Note AN607, “Power-up Trouble Shooting” (DS00607).

### 19.3.2 $\overline{MCLR}$

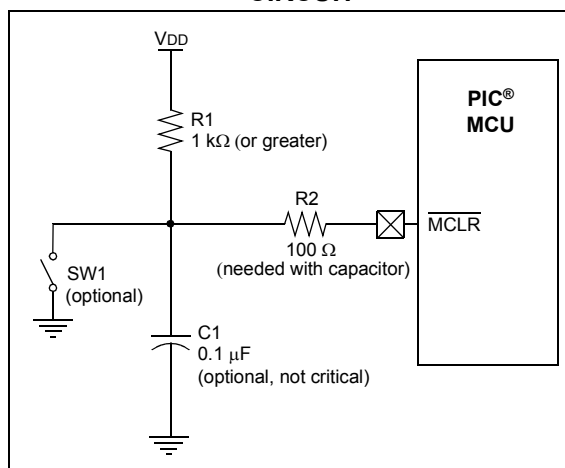
PIC16F753/HV753 has a noise filter in the  $\overline{MCLR}$  Reset path. The filter will detect and ignore small pulses.

It should be noted that a WDT Reset does not drive  $\overline{MCLR}$  pin low.

Voltages applied to the  $\overline{MCLR}$  pin that exceed its specification can result in both  $\overline{MCLR}$  Resets and excessive current beyond the device specification during the ESD event. For this reason, Microchip recommends that the  $\overline{MCLR}$  pin no longer be tied directly to VDD. The use of an RC network, as shown in [Figure 19-2](#), is suggested.

An internal  $\overline{MCLR}$  option is enabled by clearing the MCLRE bit in the Configuration Word register. When MCLRE = 0, the Reset signal to the chip is generated internally. When the MCLRE = 1, the  $\overline{MCLR}$  pin becomes an external Reset input. In this mode, the  $\overline{MCLR}$  pin has a weak pull-up to VDD.

**FIGURE 19-2: RECOMMENDED  $\overline{MCLR}$  CIRCUIT**



### 19.3.3 POWER-UP TIMER (PWRT)

The Power-up Timer provides a fixed 64 ms (nominal) time-out on power-up only, from POR or Brown-out Reset. The Power-up Timer operates from an internal RC oscillator. For more information, see [Section 4.2.2 “Internal Clock Mode”](#). The chip is kept in Reset as long as PWRT is active. The PWRT delay allows the VDD to rise to an acceptable level. A Configuration bit,  $\overline{\text{PWRT}}\text{E}$ , can disable (if set) or enable (if cleared or programmed) the Power-up Timer. The Power-up Timer should be enabled when Brown-out Reset is enabled, although it is not required.

The Power-up Timer delay will vary from chip-to-chip due to:

- VDD variation
- Temperature variation
- Process variation

See DC parameters for details ([Section 22.0 “Electrical Specifications”](#)).

**Note:** Voltage spikes below VSS at the MCLR pin, inducing currents greater than 80 mA, may cause latch-up. Thus, a series resistor of 50-100  $\Omega$  should be used when applying a “low” level to the MCLR pin, rather than pulling this pin directly to VSS.

### 19.3.4 BROWN-OUT RESET (BOR)

The BOREN<1:0> bits in the Configuration Word register select one of three BOR modes. One mode has been added to allow control of the BOR enable for lower current during Sleep. By selecting BOREN<1:0> = 10, the BOR is automatically disabled in Sleep to conserve power and enabled on wake-up. See [Register 19-1](#) for the Configuration Word definition.

A brown-out occurs when VDD falls below VBOR for greater than parameter TBOR (see [Section 22.0 “Electrical Specifications”](#)). The brown-out condition will reset the device. This will occur regardless of VDD slew rate. A Brown-out Reset may not occur if VDD falls below VBOR for less than parameter TBOR.

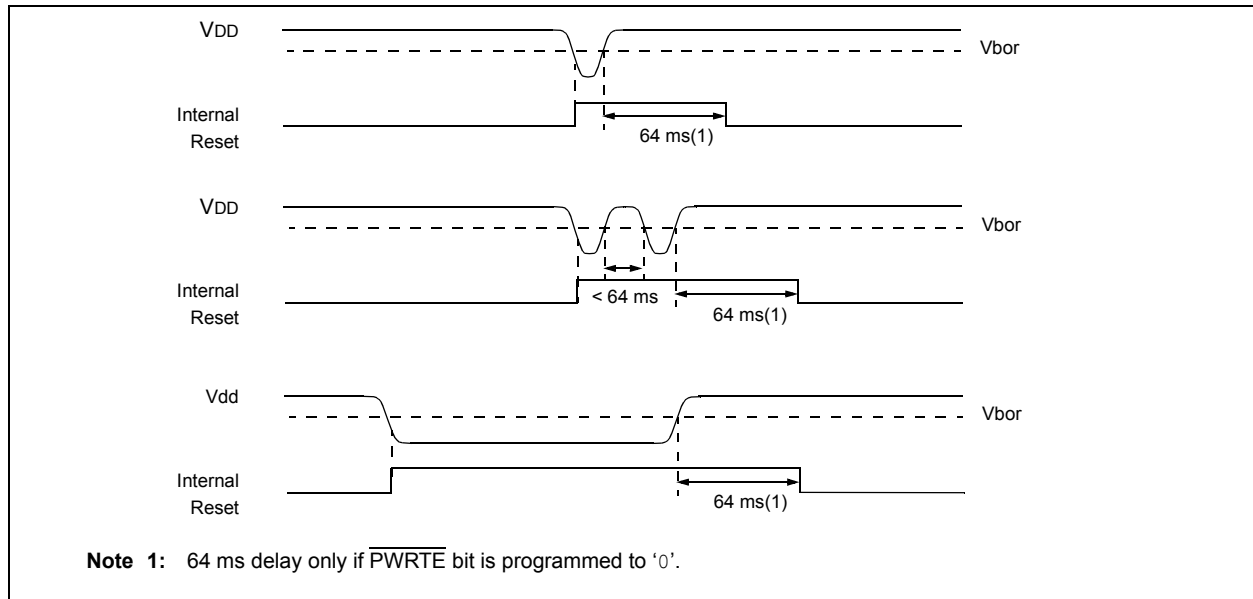
On any Reset (Power-on, Brown-out Reset, Watchdog timer, etc.), the chip will remain in Reset until VDD rises above VBOR (see [Figure 19-3](#)). If enabled, the Power-up Timer will be invoked by the Reset and keep the chip in Reset an additional 64 ms.

**Note:** The Power-up Timer is enabled by the  $\overline{\text{PWRT}}\text{E}$  bit in the Configuration Word register.

If VDD drops below VBOR while the Power-up Timer is running, the chip will go back into a Brown-out Reset and the Power-up Timer will be re-initialized. Once VDD rises above VBOR, the Power-up Timer will execute a 64 ms Reset.

[Table 19-3](#) summarizes the registers associated with BOR.

**FIGURE 19-3: BROWN-OUT SITUATIONS**



# PIC16F753/HV753

**TABLE 19-3: SUMMARY OF REGISTERS ASSOCIATED WITH BROWN-OUT RESET**

Name	Bit 7	Bit 6	Bit 5	Bit 4	Bit 3	Bit 2	Bit 1	Bit 0	Register on Page
PCON	—	—	—	—	—	—	POR	BOR	24
STATUS	IRP	RP1	RP0	TO	PD	Z	DC	C	17

**Legend:** u = unchanged, x = unknown, — = unimplemented bit, reads as '0', q = value depends on condition. Shaded cells are not used by BOR.

### 19.3.5 TIME-OUT SEQUENCE

On power-up, the time-out sequence is as follows:

- PWRT time-out is invoked after POR has expired.
- OST is activated after the PWRT time-out has expired.

The total time-out will vary based on oscillator configuration and PWRT bit status. For example, in EC mode with PWRT bit erased (PWRT disabled), there will be no time-out at all. Figure 19-4, Figure 19-5 and Figure 19-6 depict time-out sequences.

Since the time-outs occur from the POR pulse, if MCLR is kept low long enough, the time-outs will expire. Then, bringing MCLR high will begin execution immediately (see Figure 19-5). This is useful for testing purposes or to synchronize more than one PIC16F753/HV753 device operating in parallel.

Table 19-5 shows the Reset conditions for some special registers, while Table 19-4 shows the Reset conditions for all the registers.

### 19.3.6 POWER CONTROL (PCON) REGISTER

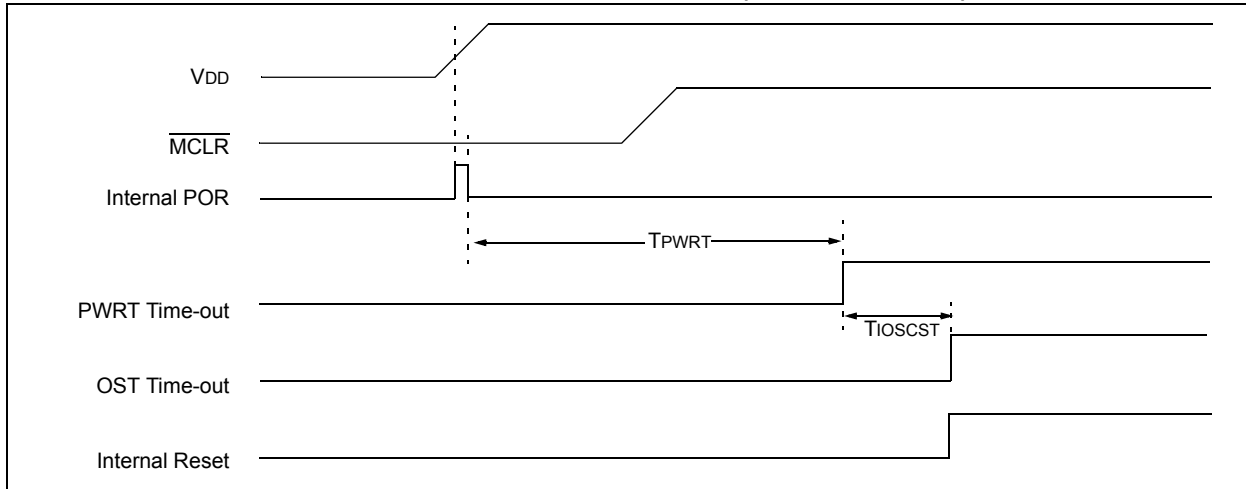
The Power Control register PCON (address 8Eh) has two Status bits to indicate what type of Reset occurred last.

Bit 0 is BOR (Brown-out). BOR is unknown on Power-on Reset. It must then be set by the user and checked on subsequent Resets to see if BOR = 0, indicating that a Brown-out has occurred. The BOR Status bit is a “don’t care” and is not necessarily predictable if the brown-out circuit is disabled (BOREN<1:0> = 00 in the Configuration Word register).

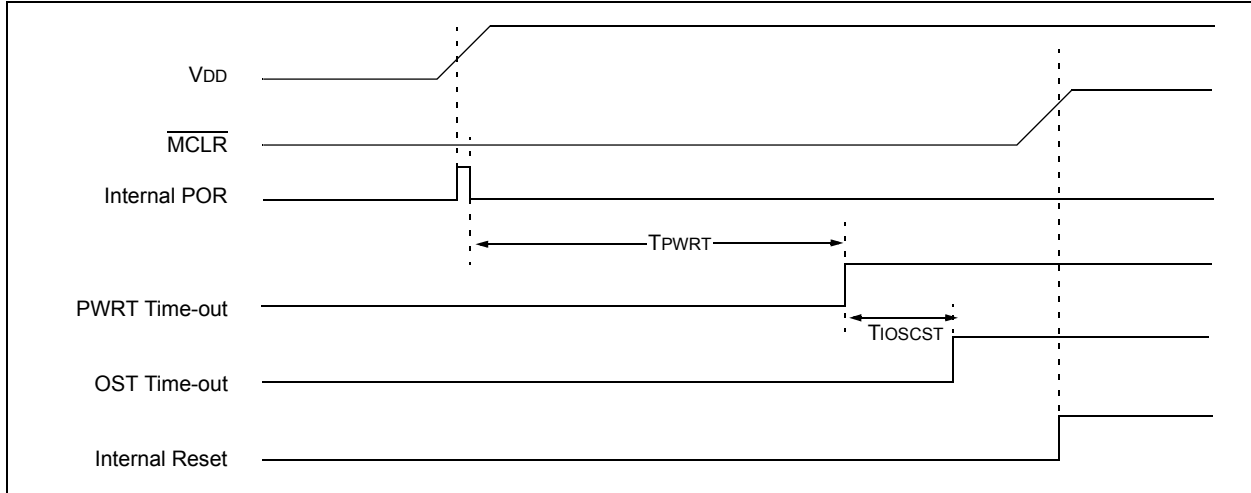
Bit 1 is POR (Power-on Reset). It is a '0' on Power-on Reset and unaffected otherwise. The user must write a '1' to this bit following a Power-on Reset. On a subsequent Reset, if POR is '0', it will indicate that a Power-on Reset has occurred (i.e., VDD may have gone too low).

For more information, see Section 19.3.4 “Brown-out Reset (BOR)”.

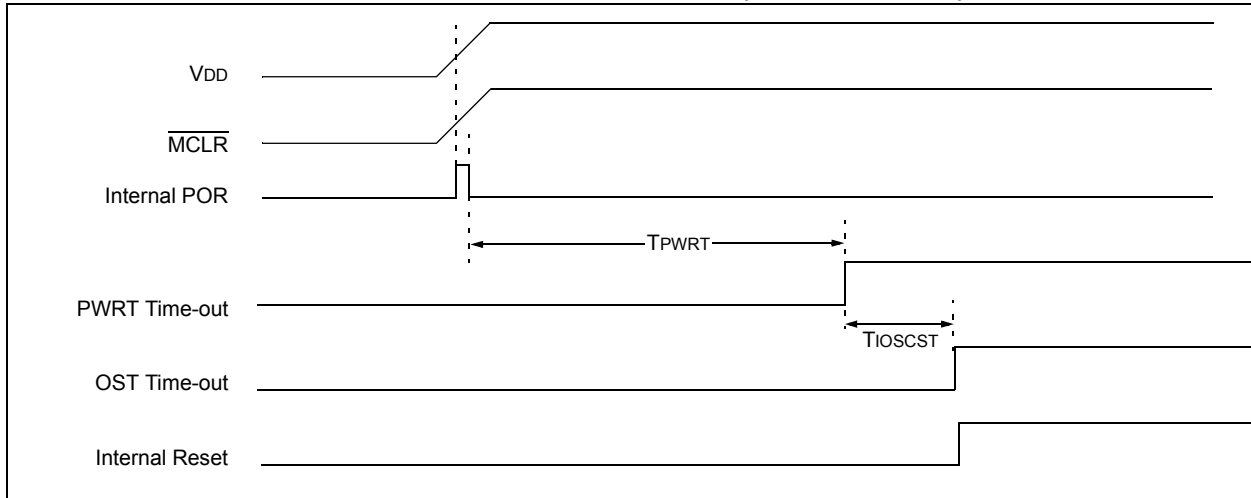
**FIGURE 19-4: TIME-OUT SEQUENCE ON POWER-UP (DELAYED MCLR): CASE 1**



**FIGURE 19-5: TIME-OUT SEQUENCE ON POWER-UP (DELAYED  $\overline{\text{MCLR}}$ ): CASE 2**



**FIGURE 19-6: TIME-OUT SEQUENCE ON POWER-UP ( $\overline{\text{MCLR}}$  WITH  $\text{V}_{\text{DD}}$ )**



# PIC16F753/HV753

**TABLE 19-4: INITIALIZATION CONDITION FOR REGISTERS**

Register	Address	Power-on Reset	MCLR Reset WDT Reset Brown-out Reset <sup>(1)</sup>	Wake-up from Sleep through Interrupt Wake-up from Sleep through WDT Time-out
W	—	xxxx xxxx	uuuu uuuu	uuuu uuuu
INDF	00h/80h/ 100h/180h	xxxx xxxx	xxxx xxxx	uuuu uuuu
TMR0	01h	xxxx xxxx	uuuu uuuu	uuuu uuuu
PCL	02h/82h/ 102h/182h	0000 0000	0000 0000	PC + 1 <sup>(3)</sup>
STATUS	03h/83h/ 103h/183h	0001 1xxx	000q quuu <sup>(4)</sup>	uuuq quuu <sup>(4)</sup>
FSR	04h/84h/ 104h/184h	xxxx xxxx	uuuu uuuu	uuuu uuuu
PORTA	05h	--xx xxxx	--uu uuuu	--uu uuuu
IOCAF	08h	--00 0000	--00 0000	--uu uuuu
PCLATH	0Ah/8Ah/ 10Ah/18Ah	---0 0000	---0 0000	---u uuuu
INTCON	0Bh/8Bh/ 10Bh/18Bh	0000 0000	0000 0000	uuuu uuuu <sup>(2)</sup>
PIR1	0Ch	00-- -0-0	00-- -0-0	uu-- -u-u <sup>(2)</sup>
PIR2	0Dh	--00 -0-0	--00 -0-0	--uu -u-u <sup>(2)</sup>
TMR1L	0Fh	xxxx xxxx	uuuu uuuu	uuuu uuuu
TMR1H	10h	xxxx xxxx	uuuu uuuu	uuuu uuuu
T1CON	11h	0000 00-0	uuuu uu-u	uuuu uu-u
T1GCON	12h	0000 0x00	0000 0x00	uuuu uuuu
CCPR1L <sup>(1)</sup>	13h	xxxx xxxx	uuuu uuuu	uuuu uuuu
CCPR1H <sup>(1)</sup>	14h	xxxx xxxx	uuuu uuuu	uuuu uuuu
CCP1CON <sup>(1)</sup>	15h	--00 0000	--00 0000	--uu uuuu
ADRESL <sup>(1)</sup>	1Ch	xxxx xxxx	uuuu uuuu	uuuu uuuu
ADRESH <sup>(1)</sup>	1Dh	xxxx xxxx	uuuu uuuu	uuuu uuuu
ADCON0 <sup>(1)</sup>	1Eh	0000 0000	0000 0000	uuuu uuuu
ADCON1 <sup>(1)</sup>	1Fh	-000 ----	-000 ----	-uuu ----
OPTION_REG	81h/181h	1111 1111	1111 1111	uuuu uuuu
TRISA	85h	--11 1111	--11 1111	--uu uuuu
IOCAP	88h	--00 0000	--00 0000	--uu uuuu
PIE1	8Ch	00-- -000	00-- -000	uu-- -uuu
PIE2	8Dh	--00 -0-0	--00 -0-0	--uu -u-u
OSCCON	8Fh	--01 -00-	--uu -uu-	--uu -uu-
FVRCON	90h	0000 ----	0000 ----	uuuu ----
DACCON0	91h	000- -0--	000- -0--	uuu- -u--
DACCON1	92h	---0 0000	---0 0000	---u uuuu
CM2CON0	9Bh	0000 0100	0000 0100	uuuu uuuu

**Legend:** u = unchanged, x = unknown, - = unimplemented bit, reads as '0', q = value depends on condition.

**Note 1:** If VDD goes too low, Power-on Reset will be activated and registers will be affected differently.

**2:** One or more bits in INTCON and/or PIRx will be affected (to cause wake-up).

**3:** When the wake-up is due to an interrupt and the GIE bit is set, the PC is loaded with the interrupt vector (0004h).

**4:** See Table 19-5 for Reset value for specific condition.

**5:** If Reset was due to brown-out, then bit 0 = 0. All other Resets will cause bit 0 = u.



**TABLE 19-4: INITIALIZATION CONDITION FOR REGISTERS (CONTINUED)**

Register	Address	Power-on Reset	MCLR Reset WDT Reset Brown-out Reset <sup>(1)</sup>	Wake-up from Sleep through Interrupt Wake-up from Sleep through WDT Time-out
CM2CON1	9Ch	0000 ---0	0000 ---0	uuuu ---u
CM1CON0	9Dh	0000 0100	0000 0100	uuuu uuuu
CM1CON1	9Eh	0000 ---0	0000 ---0	uuuu ---u
CMOUT	9Fh	---- --00	---- --00	---- --uu
LATA	105h	--xx -xxx	--uu -uuu	--uu -uuu
IOCAN	108h	--00 0000	--00 0000	--uu uuuu
WPUA	10Ch	--00 0000	--00 0000	--uu uuuu
SLRCON0	10Dh	---- -0-0	---- -0-0	---- -u-u
PCON	10Fh	---- --qq	---- --uu <sup>(1, 5)</sup>	---- --uu
TMR2	110h	0000 0000	0000 0000	uuuu uuuu
PR2	111h	1111 1111	1111 1111	uuuu uuuu
T2CON	112h	-000 0000	-000 0000	-uuu uuuu
HLTMR1	113h	0000 0000	0000 0000	uuuu uuuu
HLTPR1	114h	1111 1111	1111 1111	uuuu uuuu
HLT1CON0	115h	-000 0000	-000 0000	-uuu uuuu
HLT1CON1	116h	---0 0000	---0 0000	---u uuuu
ANSELA	185h	--11 -111	--11 -111	--uu -uuu
APFCON	188h	---0 -000	---0 -000	---u -uuu
OSCTUNE	189h	---0 0000	---u uuuu	---u uuuu
PMCON1	18Ch	---- -000	---- -000	---- -uuu
PMCON2	18Dh	---- ----	---- ----	---- ----
PMADRL	18Eh	0000 0000	0000 0000	uuuu uuuu
PMADRH	18Fh	---- --00	---- --00	---- --uu
PMDATL	190h	0000 0000	0000 0000	uuuu uuuu
PMDATH	191h	--00 0000	--00 0000	--uu uuuu
COG1PH	192h	---- xxxx	---- uuuu	---- uuuu
COG1BLK	193h	xxxx xxxx	uuuu uuuu	uuuu uuuu
COG1DB	194h	xxxx xxxx	uuuu uuuu	uuuu uuuu
COG1CON0	195h	0000 0000	0000 0000	uuuu uuuu
COG1CON1	196h	--00 0000	--00 0000	--uu uuuu
COG1ASD	197h	0000 0000	0000 0000	uuuu uuuu

**Legend:** u = unchanged, x = unknown, - = unimplemented bit, reads as '0', q = value depends on condition.

**Note 1:** If VDD goes too low, Power-on Reset will be activated and registers will be affected differently.

**2:** One or more bits in INTCON and/or PIRx will be affected (to cause wake-up).

**3:** When the wake-up is due to an interrupt and the GIE bit is set, the PC is loaded with the interrupt vector (0004h).

**4:** See [Table 19-5](#) for Reset value for specific condition.

**5:** If Reset was due to brown-out, then bit 0 = 0. All other Resets will cause bit 0 = u.

# PIC16F753/HV753

**TABLE 19-5: INITIALIZATION CONDITION FOR SPECIAL REGISTERS**

Condition	Program Counter	Status Register	PCON Register
Power-on Reset	000h	0001 1xxx	---- --0x
MCLR Reset during normal operation	000h	000u uuuu	---- --uu
MCLR Reset during Sleep	000h	0001 0uuu	---- --uu
WDT Reset	000h	0000 uuuu	---- --uu
WDT Wake-up	PC + 1	uuu0 0uuu	---- --uu
Brown-out Reset	000h	0001 1uuu	---- --u0
Interrupt Wake-up from Sleep	PC + 1 <sup>(1)</sup>	uuu1 0uuu	---- --uu

**Legend:** u = unchanged, x = unknown, – = unimplemented bit, reads as '0'.

**Note 1:** When the wake-up is due to an interrupt and Global Interrupt Enable bit, GIE is set, the PC is loaded with the interrupt vector (0004h) after execution of PC + 1.

## 19.4 Interrupts

The PIC16F753/HV753 has multiple sources of interrupt:

- External Interrupt (INT pin)
- Interrupt-On-Change (IOC) Interrupts
- Timer0 Overflow Interrupt
- Timer1 Overflow Interrupt
- Timer2 Match Interrupt
- Hardware Limit Timer (HLT) Interrupt
- Comparator Interrupt (C1/C2)
- ADC Interrupt
- Complementary Output Generator (COG)
- CCP1 Interrupt
- Flash Memory Self Write

The Interrupt Control register (INTCON) and Peripheral Interrupt Request Registers (PIRx) record individual interrupt requests in flag bits. The INTCON register also has individual and global interrupt enable bits.

The Global Interrupt Enable bit, GIE of the INTCON register, enables (if set) all unmasked interrupts, or disables (if cleared) all interrupts. Individual interrupts can be disabled through their corresponding enable bits in the INTCON register and PIEx registers. GIE is cleared on Reset.

When an interrupt is serviced, the following actions occur automatically:

- The GIE is cleared to disable any further interrupt.
- The return address is pushed onto the stack.
- The PC is loaded with 0004h.

The Return from Interrupt instruction, `RETFIE`, exits the interrupt routine, as well as sets the GIE bit, which re-enables unmasked interrupts.

The following interrupt flags are contained in the INTCON register:

- INT Pin Interrupt
- Interrupt-On-Change (IOC) Interrupts
- Timer0 Overflow Interrupt

The peripheral interrupt flags are contained in the PIR1 and PIR2 registers. The corresponding interrupt enable bit is contained in the PIE1 and PIE2 registers.

The following interrupt flags are contained in the PIR1 register:

- A/D Interrupt
- Comparator Interrupt
- Timer1 Overflow Interrupt
- Timer2 Match Interrupt
- Enhanced CCP Interrupt

For external interrupt events, such as the INT pin or PORTA change interrupt, the interrupt latency will be three or four instruction cycles. The exact latency depends upon when the interrupt event occurs (see [Figure 19-8](#)). The latency is the same for one or two-cycle instructions. Once in the Interrupt Service Routine, the source(s) of the interrupt can be determined by polling the interrupt flag bits. The interrupt flag bit(s) must be cleared in software before re-enabling interrupts to avoid multiple interrupt requests.

**Note 1:** Individual interrupt flag bits are set, regardless of the status of their corresponding mask bit or the GIE bit.

**2:** When an instruction that clears the GIE bit is executed, any interrupts that were pending for execution in the next cycle are ignored. The interrupts, which were ignored, are still pending to be serviced when the GIE bit is set again.

For additional information on Timer1, Timer2, comparators, ADC, Enhanced CCP modules, refer to the respective peripheral section.

### 19.4.1 RA2/INT INTERRUPT

The external interrupt on the RA2/INT pin is edge-triggered; either on the rising edge if the INTEDG bit of the OPTION register is set, or the falling edge, if the INTEDG bit is clear. When a valid edge appears on the RA2/INT pin, the INTF bit of the INTCON register is set. This interrupt can be disabled by clearing the INTE control bit of the INTCON register. The INTF bit must be cleared by software in the Interrupt Service Routine before re-enabling this interrupt. The RA2/INT interrupt can wake-up the processor from Sleep, if the INTE bit was set prior to going into Sleep. See [Section 19.7 “Power-Down Mode \(Sleep\)”](#) for details on Sleep and [Figure 19-10](#) for timing of wake-up from Sleep through RA2/INT interrupt.

**Note:** The ANSEL register must be initialized to configure an analog channel as a digital input. Pins configured as analog inputs will read '0' and cannot generate an interrupt.

# PIC16F753/HV753

## 19.4.2 TIMER0 INTERRUPT

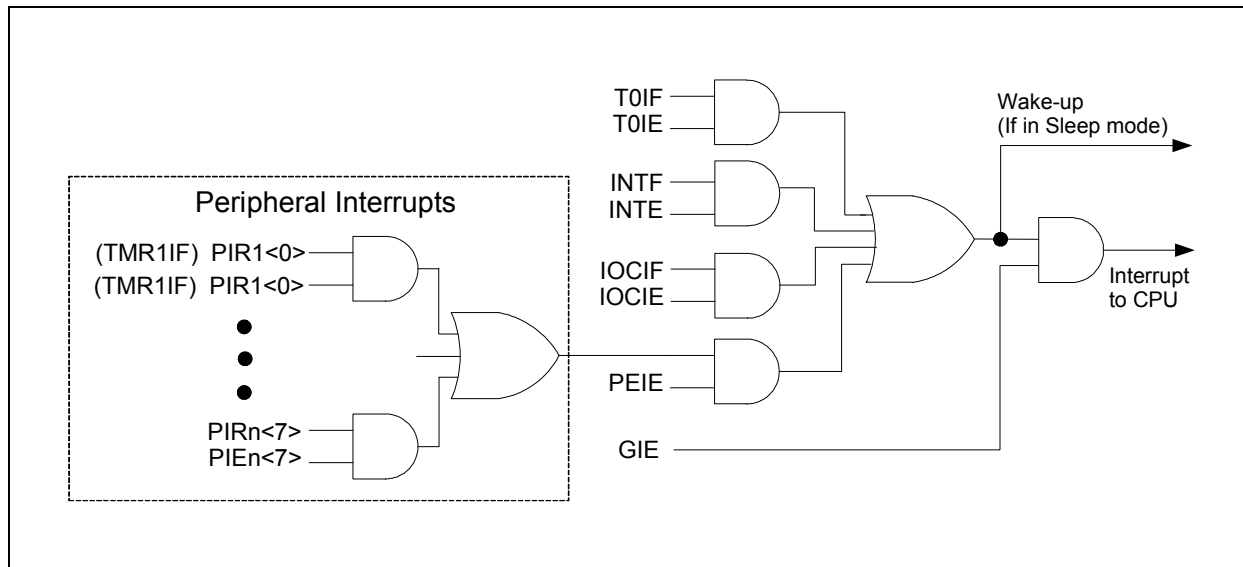
An overflow (FFh → 00h) in the TMR0 register will set the T0IF bit of the INTCON register. The interrupt can be enabled/disabled by setting/clearing T0IE bit of the INTCON register. See [Section 6.0 “Timer0 Module”](#) for operation of the Timer0 module.

## 19.4.3 PORTA INTERRUPT-ON-CHANGE

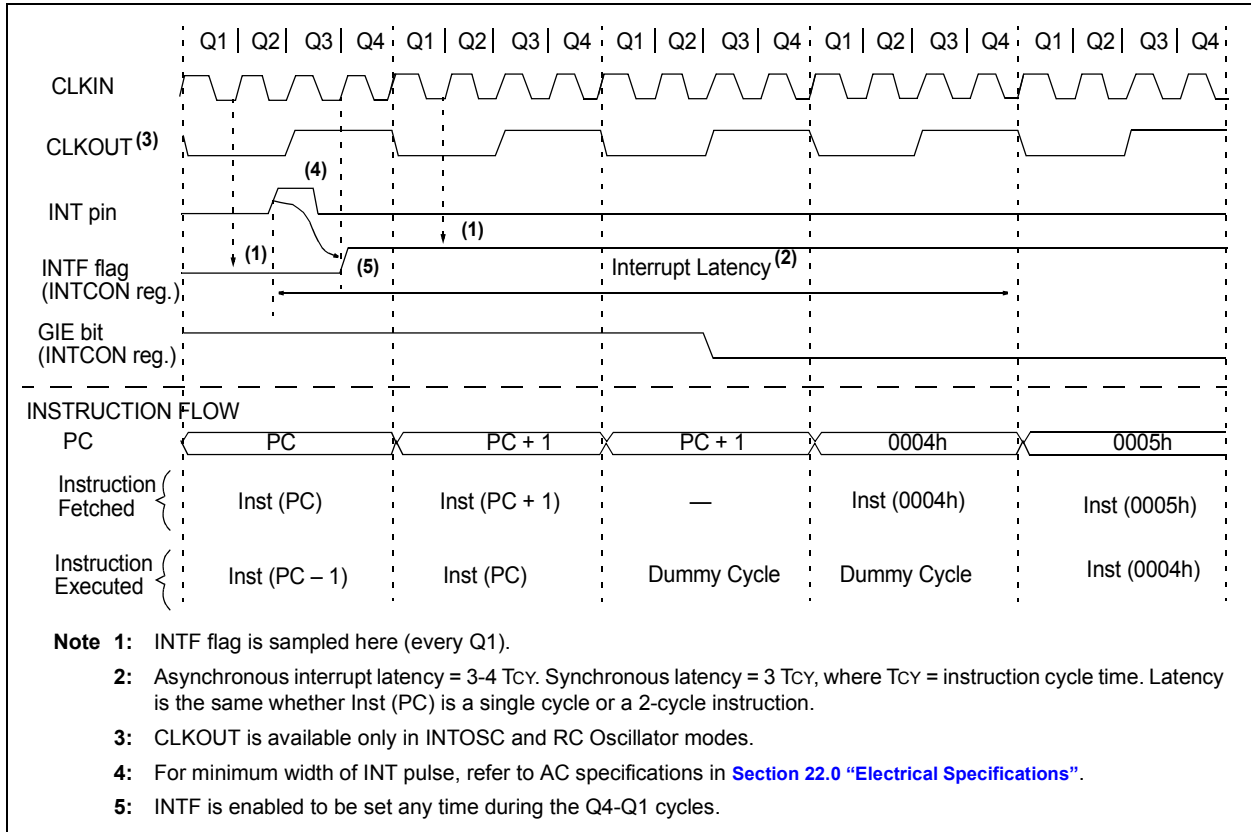
An input change on PORTA sets the IOCIF bit of the INTCON register. The interrupt can be enabled/disabled by setting/clearing the IOCIE bit of the INTCON register. Plus, individual pins can be configured through the IOC register.

**Note:** If a change on the I/O pin should occur when any PORTA operation is being executed, then the IOCIF interrupt flag may not get set.

**FIGURE 19-7: INTERRUPT LOGIC**



**FIGURE 19-8: INT PIN INTERRUPT TIMING**



**TABLE 19-6: SUMMARY OF REGISTERS ASSOCIATED WITH INTERRUPTS**

Name	Bit 7	Bit 6	Bit 5	Bit 4	Bit 3	Bit 2	Bit 1	Bit 0	Register on Page
INTCON	GIE	PEIE	T0IE	INTE	IOCFIE	T0IF	INTF	IOCFIF	19
IOCAF	—	—	IOCAF5	IOCAF4	IOCAF3	IOCAF2	IOCAF1	IOCAF0	49
IOCAN	—	—	IOCAN5	IOCAN4	IOCAN3	IOCAN2	IOCAN1	IOCAN0	49
IOCAP	—	—	IOCAP5	IOCAP4	IOCAP3	IOCAP2	IOCAP1	IOCAP0	49
LATA	—	—	LATA5	LATA4	—	LATA2	LATA1	LATA0	46
PIE1	TMR1GIE	ADIE	—	—	HLTMR2IE	HLTMR1IE	TMR2IE	TMR1IE	20
PIR1	TMR1GIF	ADIF	—	—	HLTMR2IF	HLTMR1IF	TMR2IF	TMR1IF	22

**Legend:** x = unknown, u = unchanged, — = unimplemented read as '0', q = value depends upon condition.  
 Shaded cells are not used by the interrupt module.

# PIC16F753/HV753

## 19.5 Context Saving During Interrupts

During an interrupt, only the return PC value is saved on the stack. Typically, users may wish to save key registers during an interrupt (e.g., W and STATUS registers). This must be implemented in software.

Temporary holding registers W\_TEMP and STATUS\_TEMP should be placed in the last 16 bytes of GPR (see Figure 2-2). These 16 locations are common to all banks and do not require banking. This makes context save and restore operations simpler. The code shown in Example 19-1 can be used to:

- Store the W register
- Store the STATUS register
- Execute the ISR code
- Restore the Status (and Bank Select Bit register)
- Restore the W register

**Note:** The PIC16F753/HV753 does not require saving the PCLATH. However, if computed GOTOS are used in both the ISR and the main code, the PCLATH must be saved and restored in the ISR.

### EXAMPLE 19-1: SAVING STATUS AND W REGISTERS IN RAM

```
MOVWF  W_TEMP           ;Copy W to TEMP register
SWAPF  STATUS,W         ;Swap status to be saved into W
                          ;Swaps are used because they do not affect the status bits
MOVWF  STATUS_TEMP     ;Save status to bank zero STATUS_TEMP register
:
:(ISR)                    ;Insert user code here
:
SWAPF  STATUS_TEMP,W   ;Swap STATUS_TEMP register into W
                          ;(sets bank to original state)
MOVWF  STATUS          ;Move W into STATUS register
SWAPF  W_TEMP,F        ;Swap W_TEMP
SWAPF  W_TEMP,W        ;Swap W_TEMP into W
```

## 19.6 Watchdog Timer (WDT)

The Watchdog Timer is a free running timer, using LFINTOSC oscillator as its clock source. The WDT is enabled by setting the WDTE bit of the Configuration Word (default setting). When WDTE is set, the LFINTOSC will always be enabled to provide a clock source to the WDT module.

During normal operation, a WDT time-out generates a device Reset. If the device is in Sleep mode, a WDT time-out causes the device to wake-up and continue with normal operation.

The WDT can be permanently disabled by programming the Configuration bit, WDTE, as clear (Section 19.1 “Configuration Bits”).

### 19.6.1 WDT PERIOD

The WDT has a nominal time-out period of 18 ms (with no prescaler). The time-out periods vary with temperature, VDD and process variations from part to part (see DC specs). If longer time-out periods are desired, a prescaler with a division ratio of up to 1:128 can be assigned to the WDT under software control by writing to the OPTION register. Thus, time-out periods up to 2.3 seconds can be realized.

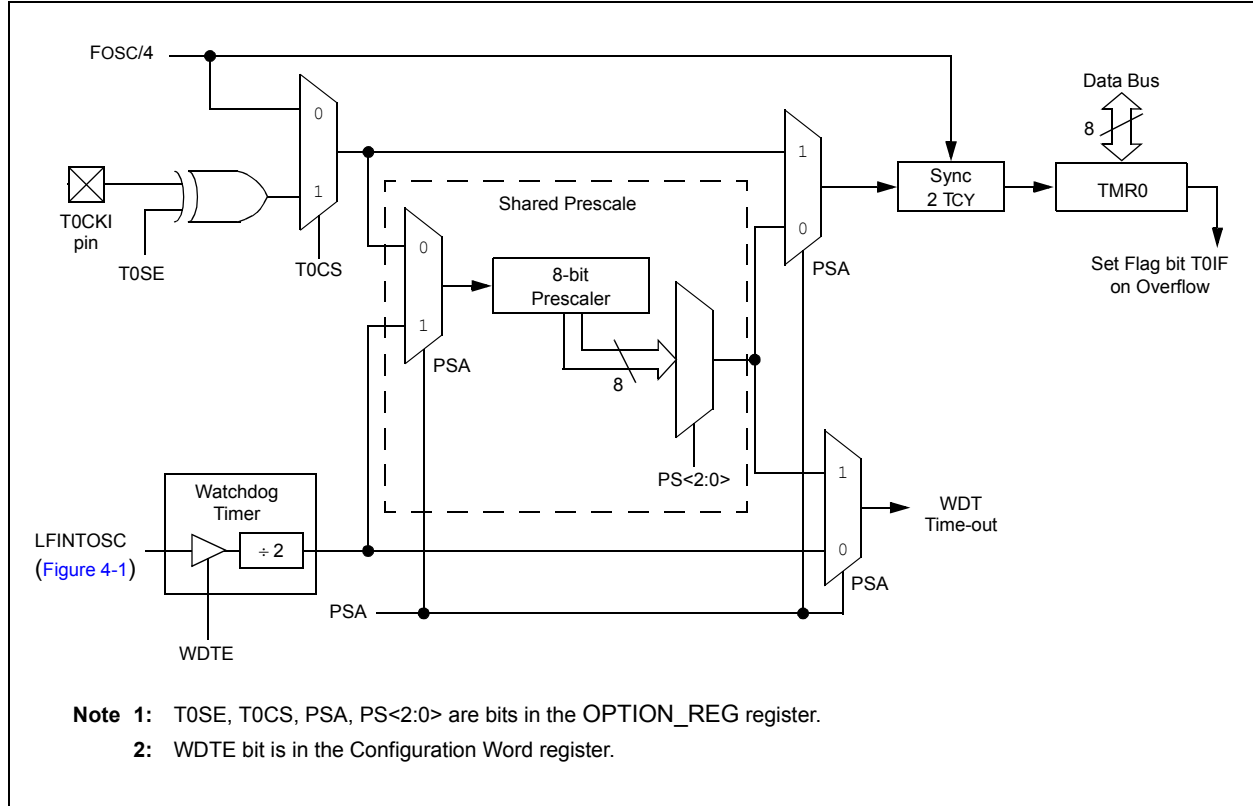
The CLRWDT and SLEEP instructions clear the WDT and the prescaler, if assigned to the WDT, and prevent it from timing out and generating a device Reset.

The  $\overline{TO}$  bit in the STATUS register will be cleared upon a Watchdog Timer time-out.

## 19.6.2 WDT PROGRAMMING CONSIDERATIONS

It should also be taken in account that under worst-case conditions (i.e.,  $V_{DD} = \text{Min.}$ , Temperature = Max., Max. WDT prescaler) it may take several seconds before a WDT time-out occurs.

**FIGURE 19-9: WATCHDOG TIMER WITH SHARED PRESCALE BLOCK DIAGRAM**



**TABLE 19-7: WDT STATUS**

Conditions	WDT
WDTE = 0	Cleared
CLRWDT Command	
Exit Sleep	

# PIC16F753/HV753

**TABLE 19-8: SUMMARY OF REGISTERS ASSOCIATED WITH WATCHDOG TIMER**

Name	Bit 7	Bit 6	Bit 5	Bit 4	Bit 3	Bit 2	Bit 1	Bit 0	Register on Page
OPTION_REG	RAPU	INTEDG	T0CS	T0SE	PSA	PS<2:0>			61

**Legend:** Shaded cells are not used by the Watchdog Timer.

**TABLE 19-9: SUMMARY OF CONFIGURATION WORD WITH WATCHDOG TIMER**

Name	Bits	Bit -/7	Bit -/6	Bit 13/5	Bit 12/4	Bit 11/3	Bit 10/2	Bit 9/1	Bit 8/0	Register on Page
CONFIG <sup>(1)</sup>	13:8	—	—	DEBUG	CLKOUTEN	WRT<1:0>		BOREN<1:0>		162
	7:0	—	CP	MCLRE	PWRTE	WDTE	—	—	FOSC0	

**Legend:** — = unimplemented location, read as '1'. Shaded cells are not used by Watchdog Timer.

**Note 1:** See [Register 19-1](#) for operation of all Configuration Word register bits.



## 19.7 Power-Down Mode (Sleep)

The Power-Down mode is entered by executing a `SLEEP` instruction.

If the Watchdog Timer is enabled:

- `WDT` will be cleared but keeps running
- `PD` bit in the `STATUS` register is cleared
- `TO` bit is set
- Oscillator driver is turned off
- I/O ports maintain the status they had before `SLEEP` was executed (driving high, low or high-impedance).

For lowest current consumption in this mode, all I/O pins should be either at `VDD` or `VSS`, with no external circuitry drawing current from the I/O pin and the comparators, DAC and FVR should be disabled. I/O pins that are high-impedance inputs should be pulled high or low externally to avoid switching currents caused by floating inputs. The `T0CKI` input should also be at `VDD` or `VSS` for lowest current consumption. The contribution from on-chip pull-ups on `PORTA` should be considered.

The `MCLR` pin must be at a logic high level.

**Note:** It should be noted that a Reset generated by a WDT time-out does not drive `MCLR` pin low.

### 19.7.1 WAKE-UP FROM SLEEP

The device can wake-up from Sleep through one of the following events:

1. External Reset input on `MCLR` pin.
2. Watchdog Timer wake-up.
3. Interrupt from `INT` pin.
4. Interrupt-On-Change input change.
5. Peripheral interrupt.

The first event will cause a device Reset. The other events are considered a continuation of program execution. The `TO` and `PD` bits in the `STATUS` register can be used to determine the cause of device Reset. The `PD` bit, which is set on power-up, is cleared when Sleep is invoked. `TO` bit is cleared if WDT wake-up occurred.

The following peripheral interrupts can wake the device from Sleep:

1. Timer1 interrupt. Timer1 must be operating as an asynchronous counter.
2. CCP Capture mode interrupt.
3. A/D conversion (when A/D clock source is RC).
4. Comparator output changes state.
5. Interrupt-on-change.
6. External Interrupt from `INT` pin.

Other peripherals cannot generate interrupts since during Sleep, no on-chip clocks are present.

When the `SLEEP` instruction is being executed, the next instruction (`PC + 1`) is prefetched. For the device to wake-up through an interrupt event, the corresponding interrupt enable bit must be set (enabled). Wake-up is regardless of the state of the `GIE` bit. If the `GIE` bit is clear (disabled), the device continues execution at the instruction after the `SLEEP` instruction. If the `GIE` bit is set (enabled), the device executes the instruction after the `SLEEP` instruction, then branches to the interrupt address (0004h). In cases where the execution of the instruction following `SLEEP` is not desirable, the user should have a `NOP` after the `SLEEP` instruction.

**Note:** If the global interrupts are disabled (`GIE` is cleared) and any interrupt source has both its interrupt enable bit and the corresponding interrupt flag bits set, the device will immediately wake-up from Sleep.

The `WDT` is cleared when the device wakes up from Sleep, regardless of the source of wake-up.

### 19.7.2 WAKE-UP USING INTERRUPTS

When global interrupts are disabled (`GIE` cleared) and any interrupt source has both its interrupt enable bit and interrupt flag bit set, one of the following will occur:

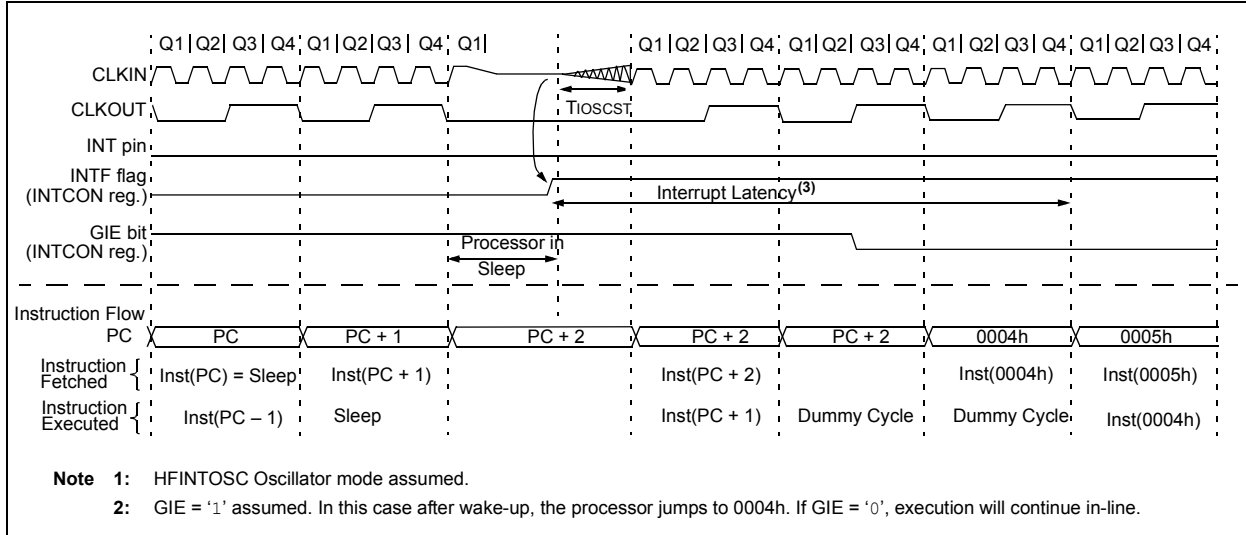
- If the interrupt occurs **before** the execution of a `SLEEP` instruction, the `SLEEP` instruction will complete as a `NOP`. Therefore, the `WDT` and `WDT` prescaler and postscaler (if enabled) will not be cleared, the `TO` bit will not be set and the `PD` bit will not be cleared.
- If the interrupt occurs **during or after** the execution of a `SLEEP` instruction, the device will immediately wake-up from Sleep. The `SLEEP` instruction is executed. Therefore, the `WDT` and `WDT` prescaler and postscaler (if enabled) will be cleared, the `TO` bit will be set and the `PD` bit will be cleared.

Even if the flag bits were checked before executing a `SLEEP` instruction, it may be possible for flag bits to become set before the `SLEEP` instruction completes. To determine whether a `SLEEP` instruction executed, test the `PD` bit. If the `PD` bit is set, the `SLEEP` instruction was executed as a `NOP`.

To ensure that the `WDT` is cleared, a `CLRWDT` instruction should be executed before a `SLEEP` instruction. See [Figure 19-10](#) for more details.

# PIC16F753/HV753

**FIGURE 19-10: WAKE-UP FROM SLEEP THROUGH INTERRUPT**



## 19.8 Code Protection

If the code protection bit(s) have not been programmed, the on-chip program memory can be read out using ICSP™ for verification purposes.

**Note:** The entire Flash program memory will be erased when the code protection is turned off. See the “PIC16F753/HV753 Flash Memory Programming Specification” (DS41686) for more information.

## 19.9 ID Locations

Four memory locations (2000h-2003h) are designated as ID locations where the user can store checksum or other code identification numbers. These locations are not accessible during normal execution but are readable and writable during Program/Verify mode. Only the Least Significant 7 bits of the ID locations are reported when using MPLAB® IDE.

## 19.10 In-Circuit Serial Programming™

The PIC16F753/HV753 microcontrollers can be serially programmed while in the end application circuit. This is simply done with five connections for:

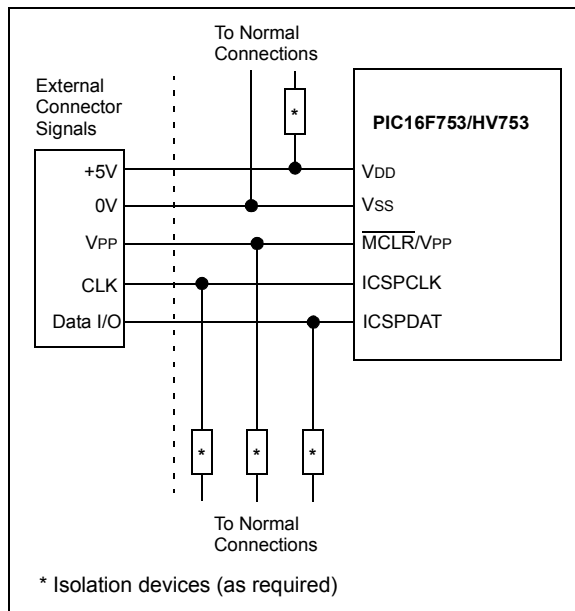
- clock
- data
- power
- ground
- programming voltage

This allows customers to manufacture boards with unprogrammed devices and then program the microcontroller just before shipping the product. This also allows the most recent firmware or a custom firmware to be programmed.

The device is placed into a Program/Verify mode by holding the  $\overline{\text{ICSPDAT}}$  and  $\overline{\text{ICSPCLK}}$  pins low, while raising the  $\overline{\text{MCLR}}$  ( $V_{PP}$ ) pin from  $V_{IL}$  to  $V_{IH}$ . See the “PIC16F753/HV753 Flash Memory Programming Specification” (DS41686) for more information.  $\overline{\text{ICSPDAT}}$  becomes the programming data and  $\overline{\text{ICSPCLK}}$  becomes the programming clock. Both  $\overline{\text{ICSPDAT}}$  and  $\overline{\text{ICSPCLK}}$  are Schmitt Trigger inputs in Program/Verify mode.

A typical In-Circuit Serial Programming connection is shown in Figure 19-11.

**FIGURE 19-11: TYPICAL IN-CIRCUIT SERIAL PROGRAMMING CONNECTION**



**Note:** To erase the device,  $V_{DD}$  must be above the Bulk Erase  $V_{DD}$  minimum given in the “PIC16F753/HV753 Flash Memory Programming Specification” (DS41686).

# PIC16F753/HV753

---

NOTES:

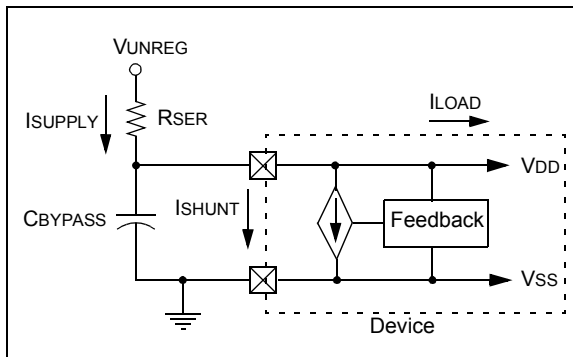
## 20.0 SHUNT REGULATOR (PIC16HV753 ONLY)

The PIC16HV753 devices include a permanent internal 5 volt (nominal) shunt regulator in parallel with the VDD pin. This eliminates the need for an external voltage regulator in systems sourced by an unregulated supply. All external devices connected directly to the VDD pin will share the regulated supply voltage and contribute to the total VDD supply current (ILOAD).

### 20.1 Regulator Operation

A shunt regulator generates a specific supply voltage by creating a voltage drop across a pass resistor RSER. The voltage at the VDD pin of the microcontroller is monitored and compared to an internal voltage reference. The current through the resistor is then adjusted, based on the result of the comparison, to produce a voltage drop equal to the difference between the supply voltage VUNREG and the VDD of the microcontroller. See Figure 20-1 for voltage regulator schematic.

**FIGURE 20-1: SHUNT REGULATOR**



An external current limiting resistor, RSER, located between the unregulated supply, VUNREG, and the VDD pin, drops the difference in voltage between VUNREG and VDD. RSER must be between RMAX and RMIN as defined by Equation 20-1.

### EQUATION 20-1: RSER LIMITING RESISTOR

$$R_{MAX} = \frac{(V_{UMIN} - 5V)}{1.05 \cdot (I_{MA} + I_{LOAD})}$$

$$R_{MIN} = \frac{(V_{UMAX} - 5V)}{0.95 \cdot (50 \text{ MA})}$$

Where:

RMAX = maximum value of RSER (ohms)

RMIN = minimum value of RSER (ohms)

VUMIN = minimum value of VUNREG

VUMAX = maximum value of VUNREG

VDD = regulated voltage (5V nominal)

ILOAD = maximum expected load current in mA including I/O pin currents and external circuits connected to VDD.

1.05 = compensation for +5% tolerance of RSER

0.95 = compensation for -5% tolerance of RSER

### 20.2 Regulator Considerations

The supply voltage VUNREG and load current are not constant. Therefore, the current range of the regulator is limited. Selecting a value for RSER must take these three factors into consideration.

Since the regulator uses the band gap voltage as the regulated voltage reference, this voltage reference is permanently enabled in the PIC16HV753 devices.

The shunt regulator will still consume current when below operating voltage range for the shunt regulator.

### 20.3 Design Considerations

For more information on using the shunt regulator and managing current load, see Application Note AN1035, "Designing with HV Microcontrollers" (DS01035).

# PIC16F753/HV753

---

NOTES:

## 21.0 DEVELOPMENT SUPPORT

The PIC<sup>®</sup> microcontrollers (MCU) and dsPIC<sup>®</sup> digital signal controllers (DSC) are supported with a full range of software and hardware development tools:

- Integrated Development Environment
  - MPLAB<sup>®</sup> X IDE Software
- Compilers/Assemblers/Linkers
  - MPLAB XC Compiler
  - MPASM<sup>™</sup> Assembler
  - MPLINK<sup>™</sup> Object Linker/  
MPLIB<sup>™</sup> Object Librarian
  - MPLAB Assembler/Linker/Librarian for  
Various Device Families
- Simulators
  - MPLAB X SIM Software Simulator
- Emulators
  - MPLAB REAL ICE<sup>™</sup> In-Circuit Emulator
- In-Circuit Debuggers/Programmers
  - MPLAB ICD 3
  - PICKit<sup>™</sup> 3
- Device Programmers
  - MPLAB PM3 Device Programmer
- Low-Cost Demonstration/Development Boards,  
Evaluation Kits and Starter Kits
- Third-party development tools

## 21.1 MPLAB X Integrated Development Environment Software

The MPLAB X IDE is a single, unified graphical user interface for Microchip and third-party software, and hardware development tool that runs on Windows<sup>®</sup>, Linux and Mac OS<sup>®</sup> X. Based on the NetBeans IDE, MPLAB X IDE is an entirely new IDE with a host of free software components and plug-ins for high-performance application development and debugging. Moving between tools and upgrading from software simulators to hardware debugging and programming tools is simple with the seamless user interface.

With complete project management, visual call graphs, a configurable watch window and a feature-rich editor that includes code completion and context menus, MPLAB X IDE is flexible and friendly enough for new users. With the ability to support multiple tools on multiple projects with simultaneous debugging, MPLAB X IDE is also suitable for the needs of experienced users.

Feature-Rich Editor:

- Color syntax highlighting
- Smart code completion makes suggestions and provides hints as you type
- Automatic code formatting based on user-defined rules
- Live parsing

User-Friendly, Customizable Interface:

- Fully customizable interface: toolbars, toolbar buttons, windows, window placement, etc.
- Call graph window

Project-Based Workspaces:

- Multiple projects
- Multiple tools
- Multiple configurations
- Simultaneous debugging sessions

File History and Bug Tracking:

- Local file history feature
- Built-in support for Bugzilla issue tracker

## 21.2 MPLAB XC Compilers

The MPLAB XC Compilers are complete ANSI C compilers for all of Microchip's 8, 16, and 32-bit MCU and DSC devices. These compilers provide powerful integration capabilities, superior code optimization and ease of use. MPLAB XC Compilers run on Windows, Linux or MAC OS X.

For easy source level debugging, the compilers provide debug information that is optimized to the MPLAB X IDE.

The free MPLAB XC Compiler editions support all devices and commands, with no time or memory restrictions, and offer sufficient code optimization for most applications.

MPLAB XC Compilers include an assembler, linker and utilities. The assembler generates relocatable object files that can then be archived or linked with other relocatable object files and archives to create an executable file. MPLAB XC Compiler uses the assembler to produce its object file. Notable features of the assembler include:

- Support for the entire device instruction set
- Support for fixed-point and floating-point data
- Command-line interface
- Rich directive set
- Flexible macro language
- MPLAB X IDE compatibility

## 21.3 MPASM Assembler

The MPASM Assembler is a full-featured, universal macro assembler for PIC10/12/16/18 MCUs.

The MPASM Assembler generates relocatable object files for the MPLINK Object Linker, Intel® standard HEX files, MAP files to detail memory usage and symbol reference, absolute LST files that contain source lines and generated machine code, and COFF files for debugging.

The MPASM Assembler features include:

- Integration into MPLAB X IDE projects
- User-defined macros to streamline assembly code
- Conditional assembly for multipurpose source files
- Directives that allow complete control over the assembly process

## 21.4 MPLINK Object Linker/ MPLIB Object Librarian

The MPLINK Object Linker combines relocatable objects created by the MPASM Assembler. It can link relocatable objects from precompiled libraries, using directives from a linker script.

The MPLIB Object Librarian manages the creation and modification of library files of precompiled code. When a routine from a library is called from a source file, only the modules that contain that routine will be linked in with the application. This allows large libraries to be used efficiently in many different applications.

The object linker/library features include:

- Efficient linking of single libraries instead of many smaller files
- Enhanced code maintainability by grouping related modules together
- Flexible creation of libraries with easy module listing, replacement, deletion and extraction

## 21.5 MPLAB Assembler, Linker and Librarian for Various Device Families

MPLAB Assembler produces relocatable machine code from symbolic assembly language for PIC24, PIC32 and dsPIC DSC devices. MPLAB XC Compiler uses the assembler to produce its object file. The assembler generates relocatable object files that can then be archived or linked with other relocatable object files and archives to create an executable file. Notable features of the assembler include:

- Support for the entire device instruction set
- Support for fixed-point and floating-point data
- Command-line interface
- Rich directive set
- Flexible macro language
- MPLAB X IDE compatibility



## 21.6 MPLAB X SIM Software Simulator

The MPLAB X SIM Software Simulator allows code development in a PC-hosted environment by simulating the PIC MCUs and dsPIC DSCs on an instruction level. On any given instruction, the data areas can be examined or modified and stimuli can be applied from a comprehensive stimulus controller. Registers can be logged to files for further run-time analysis. The trace buffer and logic analyzer display extend the power of the simulator to record and track program execution, actions on I/O, most peripherals and internal registers.

The MPLAB X SIM Software Simulator fully supports symbolic debugging using the MPLAB XC Compilers, and the MPASM and MPLAB Assemblers. The software simulator offers the flexibility to develop and debug code outside of the hardware laboratory environment, making it an excellent, economical software development tool.

## 21.7 MPLAB REAL ICE In-Circuit Emulator System

The MPLAB REAL ICE In-Circuit Emulator System is Microchip's next generation high-speed emulator for Microchip Flash DSC and MCU devices. It debugs and programs all 8, 16 and 32-bit MCU, and DSC devices with the easy-to-use, powerful graphical user interface of the MPLAB X IDE.

The emulator is connected to the design engineer's PC using a high-speed USB 2.0 interface and is connected to the target with either a connector compatible with in-circuit debugger systems (RJ-11) or with the new high-speed, noise tolerant, Low-Voltage Differential Signal (LVDS) interconnection (CAT5).

The emulator is field upgradable through future firmware downloads in MPLAB X IDE. MPLAB REAL ICE offers significant advantages over competitive emulators including full-speed emulation, run-time variable watches, trace analysis, complex breakpoints, logic probes, a ruggedized probe interface and long (up to three meters) interconnection cables.

## 21.8 MPLAB ICD 3 In-Circuit Debugger System

The MPLAB ICD 3 In-Circuit Debugger System is Microchip's most cost-effective, high-speed hardware debugger/programmer for Microchip Flash DSC and MCU devices. It debugs and programs PIC Flash microcontrollers and dsPIC DSCs with the powerful, yet easy-to-use graphical user interface of the MPLAB IDE.

The MPLAB ICD 3 In-Circuit Debugger probe is connected to the design engineer's PC using a high-speed USB 2.0 interface and is connected to the target with a connector compatible with the MPLAB ICD 2 or MPLAB REAL ICE systems (RJ-11). MPLAB ICD 3 supports all MPLAB ICD 2 headers.

## 21.9 PICkit 3 In-Circuit Debugger/Programmer

The MPLAB PICkit 3 allows debugging and programming of PIC and dsPIC Flash microcontrollers at a most affordable price point using the powerful graphical user interface of the MPLAB IDE. The MPLAB PICkit 3 is connected to the design engineer's PC using a full-speed USB interface and can be connected to the target via a Microchip debug (RJ-11) connector (compatible with MPLAB ICD 3 and MPLAB REAL ICE). The connector uses two device I/O pins and the Reset line to implement in-circuit debugging and In-Circuit Serial Programming™ (ICSP™).

## 21.10 MPLAB PM3 Device Programmer

The MPLAB PM3 Device Programmer is a universal, CE compliant device programmer with programmable voltage verification at VDDMIN and VDDMAX for maximum reliability. It features a large LCD display (128 x 64) for menus and error messages, and a modular, detachable socket assembly to support various package types. The ICSP cable assembly is included as a standard item. In Stand-Alone mode, the MPLAB PM3 Device Programmer can read, verify and program PIC devices without a PC connection. It can also set code protection in this mode. The MPLAB PM3 connects to the host PC via an RS-232 or USB cable. The MPLAB PM3 has high-speed communications and optimized algorithms for quick programming of large memory devices, and incorporates an MMC card for file storage and data applications.

## 21.11 Demonstration/Development Boards, Evaluation Kits, and Starter Kits

A wide variety of demonstration, development and evaluation boards for various PIC MCUs and dsPIC DSCs allows quick application development on fully functional systems. Most boards include prototyping areas for adding custom circuitry and provide application firmware and source code for examination and modification.

The boards support a variety of features, including LEDs, temperature sensors, switches, speakers, RS-232 interfaces, LCD displays, potentiometers and additional EEPROM memory.

The demonstration and development boards can be used in teaching environments, for prototyping custom circuits and for learning about various microcontroller applications.

In addition to the PICDEM™ and dsPICDEM™ demonstration/development board series of circuits, Microchip has a line of evaluation kits and demonstration software for analog filter design, KEELOQ® security ICs, CAN, IrDA®, PowerSmart battery management, SEEVAL® evaluation system, Sigma-Delta ADC, flow rate sensing, plus many more.

Also available are starter kits that contain everything needed to experience the specified device. This usually includes a single application and debug capability, all on one board.

Check the Microchip web page ([www.microchip.com](http://www.microchip.com)) for the complete list of demonstration, development and evaluation kits.

## 21.12 Third-Party Development Tools

Microchip also offers a great collection of tools from third-party vendors. These tools are carefully selected to offer good value and unique functionality.

- Device Programmers and Gang Programmers from companies, such as SoftLog and CCS
- Software Tools from companies, such as Gimpel and Trace Systems
- Protocol Analyzers from companies, such as Saleae and Total Phase
- Demonstration Boards from companies, such as MikroElektronika, Digilent® and Olimex
- Embedded Ethernet Solutions from companies, such as EZ Web Lynx, WIZnet and IPLogika®

## 22.0 ELECTRICAL SPECIFICATIONS

### Absolute Maximum Ratings<sup>(†)</sup>

Ambient temperature under bias .....	-40° to +125°C
Storage temperature .....	-65°C to +150°C
Voltage on VDD with respect to VSS .....	-0.3V to +6.5V
Voltage on $\overline{\text{MCLR}}$ with respect to VSS .....	-0.3V to +13.5V
Voltage on all other pins with respect to VSS .....	-0.3V to (VDD + 0.3V)
Total power dissipation <sup>(1)</sup> .....	800 mW
Maximum current out of VSS pin .....	95 mA
Maximum current into VDD pin .....	95 mA
Input clamp current, I <sub>IK</sub> (V <sub>I</sub> < 0 or V <sub>I</sub> > VDD) .....	± 20 mA
Output clamp current, I <sub>OK</sub> (V <sub>O</sub> < 0 or V <sub>O</sub> > VDD) .....	± 20 mA
Maximum output current sunk by any I/O pin .....	25 mA <sup>(2)</sup>
Maximum output current sourced by any I/O pin .....	25 mA <sup>(2)</sup>
Maximum current sunk by PORTA .....	90 mA
Maximum current sourced PORTA .....	90 mA

**Note 1:** Power dissipation is calculated as follows:  $P_{DIS} = V_{DD} \times \{I_{DD} - \sum I_{OH}\} + \sum \{(V_{DD} - V_{OH}) \times I_{OH}\} + \sum (V_{OL} \times I_{OL})$ .

**2:** 50 mA for RA0 and RA2.

† NOTICE: Stresses above those listed under “Absolute Maximum Ratings” may cause permanent damage to the device. This is a stress rating only and functional operation of the device at those or any other conditions above those indicated in the operation listings of this specification is not implied. Exposure above maximum rating conditions for extended periods may affect device reliability.

# PIC16F753/HV753

FIGURE 22-1: PIC16F753 VOLTAGE-FREQUENCY GRAPH,  $-40^{\circ}\text{C} \leq T_A \leq +125^{\circ}\text{C}$

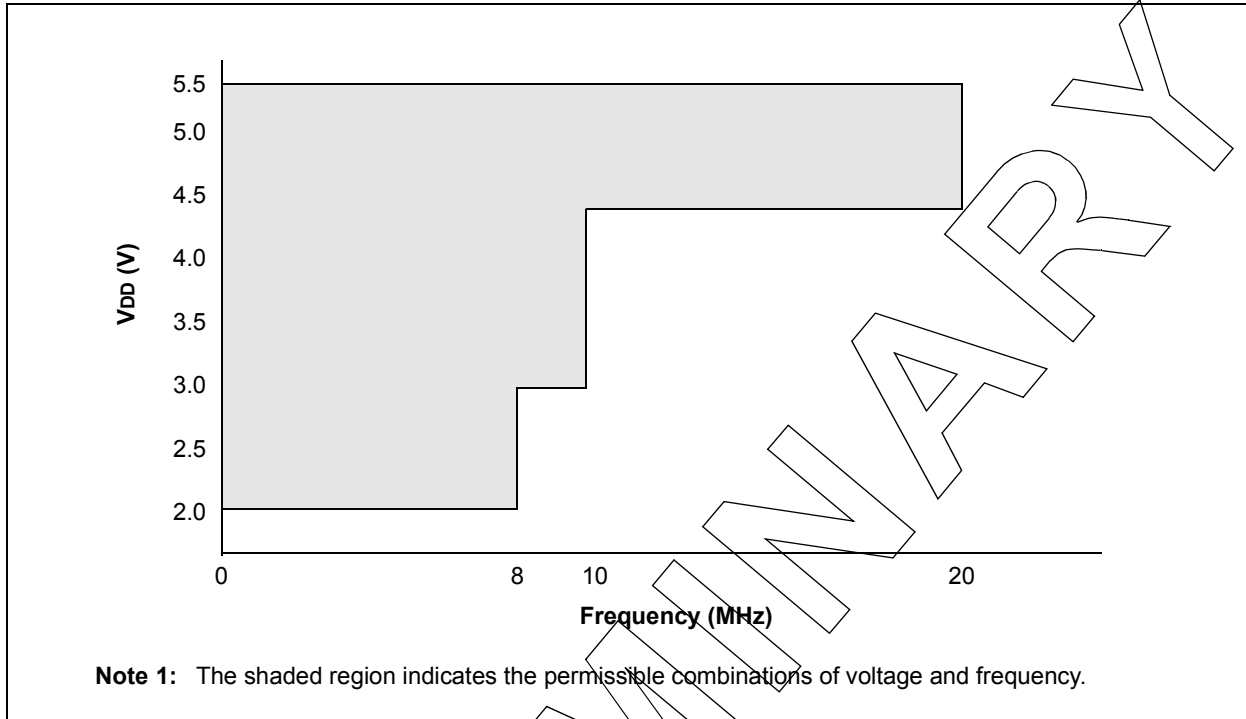
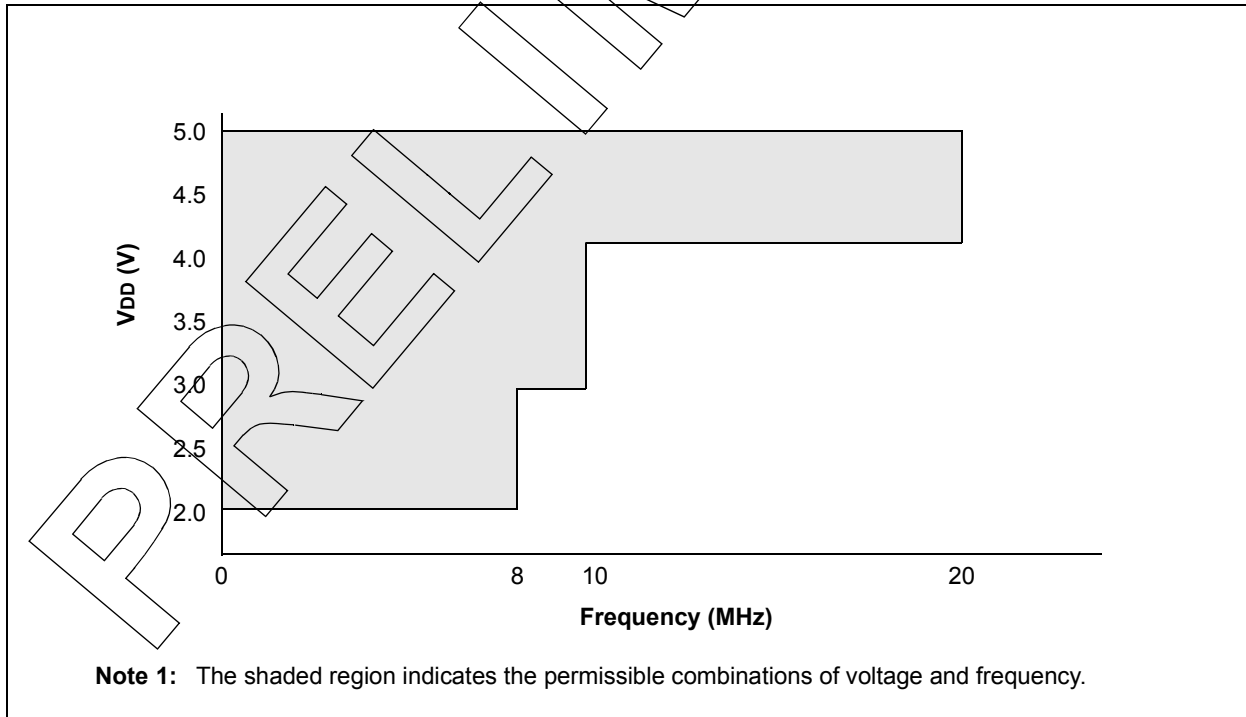


FIGURE 22-2: PIC16HV753 VOLTAGE-FREQUENCY GRAPH,  $-40^{\circ}\text{C} \leq T_A \leq +125^{\circ}\text{C}$



## 22.1 DC Characteristics: PIC16F753/HV753-I (Industrial) PIC16F753/HV753-E (Extended)

DC CHARACTERISTICS			Standard Operating Conditions (unless otherwise stated)				
			Operating temperature $-40^{\circ}\text{C} \leq T_A \leq +85^{\circ}\text{C}$ for industrial $-40^{\circ}\text{C} \leq T_A \leq +125^{\circ}\text{C}$ for extended				
Param. No.	Sym.	Characteristic	Min.	Typ†	Max.	Units	Conditions
<b>Supply Voltage</b>							
D001	VDD	PIC16F753	2.0	—	5.5	V	Fosc ≤ 4 MHz
D001		PIC16HV753	2.0	—	5.0 <sup>(2)</sup>	V	Fosc ≤ 4 MHz
D001B	VDD	PIC16F753	2.0	—	5.5	V	Fosc ≤ 8 MHz
D001B		PIC16HV753	2.0	—	5.0 <sup>(2)</sup>	V	Fosc ≤ 8 MHz
D001C	VDD	PIC16F753	3.0	—	5.5	V	Fosc ≤ 10 MHz
D001C		PIC16HV753	3.0	—	5.0 <sup>(2)</sup>	V	Fosc ≤ 10 MHz
D001D	VDD	PIC16F753	4.5	—	5.5	V	Fosc ≤ 20 MHz
D001D		PIC16HV753	4.5	—	5.0 <sup>(2)</sup>	V	Fosc ≤ 20 MHz
D002*	VDR	<b>RAM Data Retention Voltage<sup>(1)</sup></b>	1.5	—	—	V	Device in Sleep mode
D003	VPOR	<b>VDD Start Voltage</b> to ensure internal Power-on Reset signal	—	VSS	—	V	See <a href="#">Table 19-1</a> for details
D004*	SVDD	<b>VDD Rise Rate</b> to ensure internal Power-on Reset signal	0.05	—	—	V/ms	See <a href="#">Table 19-1</a> for details

\* These parameters are characterized but not tested.

† Data in "Typ" column is at 5.0V, 25°C unless otherwise stated. These parameters are for design guidance only and are not tested.

**Note 1:** This is the limit to which VDD can be lowered in Sleep mode without losing RAM data.

**Note 2:** On the PIC16HV753, VDD is regulated by a Shunt Regulator and is dependent on series resistor (connected between the unregulated supply voltage and the VDD pin) to limit the current to 50 mA. See [Section 20.0 "Shunt Regulator \(PIC16HV753 Only\)"](#) for design requirements.

# PIC16F753/HV753

## 22.2 DC Characteristics: PIC16F753-I (Industrial) PIC16F753-E (Extended)

DC CHARACTERISTICS		Standard Operating Conditions (unless otherwise stated)					
		Operating temperature -40°C ≤ TA ≤ +85°C for industrial -40°C ≤ TA ≤ +125°C for extended					
Param. No.	Device Characteristics	Min.	Typ†	Max.	Units	Conditions	
						VDD	Note
D010	Supply Current (IDD) <sup>(1, 2)</sup> PIC16F753	—	8	TBD	μA	2.0	Fosc = 31 kHz
		—	16	TBD	μA	3.0	LFINTOSC
		—	31	TBD	μA	5.0	
D011*		—	140	TBD	μA	2.0	Fosc = 1 MHz
		—	215	TBD	μA	3.0	HFINTOSC
		—	360	TBD	μA	5.0	
D012*		—	185	TBD	μA	2.0	Fosc = 4 MHz
		—	325	TBD	μA	3.0	EC Oscillator
		—	665	TBD	μA	5.0	
D013*		—	270	TBD	μA	2.0	Fosc = 4 MHz
		—	390	TBD	μA	3.0	HFINTOSC
		—	680	TBD	μA	5.0	
D014		—	0.395	TBD	mA	2.0	Fosc = 8 MHz
		—	0.620	TBD	mA	3.0	HFINTOSC
		—	1.2	TBD	mA	5.0	
D015		—	2.6	TBD	mA	4.5	Fosc = 20 MHz
		—	2.8	TBD	mA	5.0	EC Oscillator
D016		—	65	—	μA	2.0	Fosc = 1 MHz
		—	120	—	μA	3.0	EC Oscillator
		—	250	—	μA	5.0	

**Legend:** TBD = To Be Determined

\* These parameters are characterized but not tested.

† Data in "Typ" column is at 5.0V, 25°C unless otherwise stated. These parameters are for design guidance only and are not tested.

**Note 1:** The test conditions for all IDD measurements in active operation mode are: CLKIN = external square wave, from rail-to-rail; all I/O pins tri-stated, pulled to VDD; MCLR = VDD; WDT disabled.

**2:** The supply current is mainly a function of the operating voltage and frequency. Other factors, such as I/O pin loading and switching rate, oscillator type, internal code execution pattern and temperature, also have an impact on the current consumption.

## 22.3 DC Characteristics: PIC16HV753-I (Industrial) PIC16HV753-E (Extended)

DC CHARACTERISTICS		Standard Operating Conditions (unless otherwise stated)					
		Operating temperature -40°C ≤ TA ≤ +85°C for industrial -40°C ≤ TA ≤ +125°C for extended					
Param. No.	Device Characteristics	Min.	Typ†	Max.	Units	Conditions	
						VDD	Note
D010	Supply Current (IDD) <sup>(1,2,3)</sup> PIC16HV753	—	20	TBD	μA	2.0	Fosc = 31 kHz LFINTOSC
		—	40	TBD	μA	3.0	
		—	65	TBD	μA	4.5	
D011*		—	215	TBD	μA	2.0	Fosc = 1 MHz HFINTOSC Oscillator
		—	375	TBD	μA	3.0	
		—	570	TBD	μA	4.5	
D012*		—	335	TBD	μA	2.0	Fosc = 4 MHz HFINTOSC
		—	535	TBD	μA	3.0	
		—	795	TBD	μA	4.5	
D013		—	0.530	TBD	mA	2.0	Fosc = 8 MHz HFINTOSC
		—	0.830	TBD	mA	3.0	
		—	1.35	TBD	mA	4.5	
D014		—	3.8	TBD	mA	4.5	Fosc = 20 MHz EC Oscillator
D015		—	130	—	μA	2.0	Fosc = 1 MHz EC Oscillator
		—	245	—	μA	3.0	
		—	360	—	μA	5.0	
D016		—	250	—	μA	2.0	Fosc = 4 MHz EC Oscillator
		—	440	—	μA	3.0	
		—	660	—	μA	5.0	

**Legend:** TBD = To Be Determined

\* These parameters are characterized but not tested.

† Data in "Typ" column is at 4.5V, 25°C unless otherwise stated. These parameters are for design guidance only and are not tested.

**Note 1:** The test conditions for all IDD measurements in active operation mode are: CLKIN = external square wave, from rail-to-rail; all I/O pins tri-stated, pulled to VDD; MCLR = VDD; WDT disabled.

**2:** The supply current is mainly a function of the operating voltage and frequency. Other factors, such as I/O pin loading and switching rate, oscillator type, internal code execution pattern and temperature, also have an impact on the current consumption.

**3:** For RC oscillator configurations, current through REXT is not included. The current through the resistor can be extended by the formula  $I_R = V_{DD}/2R_{EXT}$  (mA) with REXT in kΩ.

# PIC16F753/HV753

## 22.4 DC Characteristics: PIC16F753-I (Industrial)

DC CHARACTERISTICS		Standard Operating Conditions (unless otherwise stated) Operating temperature $-40^{\circ}\text{C} \leq T_A \leq +85^{\circ}\text{C}$ for industrial					
Param. No.	Device Characteristics	Min.	Typ†	Max.	Units	Conditions	
						VDD	Note
D020	Power-down Base Current (IPD) <sup>(2)</sup>  PIC16F753	—	0.01	TBD	$\mu\text{A}$	2.0	WDT, BOR, Comparator, VREF and T1OSC disabled  $40^{\circ}\text{C} \leq T_A \leq +25^{\circ}\text{C}$ for industrial
		—	0.3	TBD	$\mu\text{A}$	3.0	
		—	0.5	TBD	$\mu\text{A}$	5.0	
		—	150	TBD	nA	3.0	
D021		—	3.0	TBD	$\mu\text{A}$	2.0	WDT Current <sup>(1)</sup>
		—	4.0	TBD	$\mu\text{A}$	3.0	
		—	7.0	TBD	$\mu\text{A}$	5.0	
D022		—	5.0	TBD	$\mu\text{A}$	3.0	BOR Current <sup>(1)</sup>
		—	6.0	TBD	$\mu\text{A}$	5.0	
D023		—	362	TBD	$\mu\text{A}$	2.0	CxSP = 1, Comparator Current <sup>(1)</sup> , single comparator enabled
		—	418	TBD	$\mu\text{A}$	3.0	
		—	500	TBD	$\mu\text{A}$	5.0	
D024		—	96	TBD	$\mu\text{A}$	2.0	CxSP = 0, Comparator Current <sup>(1)</sup> , single comparator enabled
		—	112	TBD	$\mu\text{A}$	3.0	
		—	132	TBD	$\mu\text{A}$	5.0	
D025		—	0.3	TBD	$\mu\text{A}$	3.0	A/D Current <sup>(1)</sup> , no conversion in progress
		—	0.36	TBD	$\mu\text{A}$	5.0	
D026		—	0.2	TBD	$\mu\text{A}$	3.0	DAC Current <sup>(1)</sup>
		—	0.4	TBD	$\mu\text{A}$	5.0	
D027		—	50	TBD	$\mu\text{A}$	3.0	FVR Current <sup>(1)</sup> , FVRBUFEN = 1, REFOUT buffer enabled
		—	98	TBD	$\mu\text{A}$	5.0	

**Legend:** TBD = To Be Determined

\* These parameters are characterized but not tested.

† Data in "Typ" column is at 5.0V, 25°C unless otherwise stated. These parameters are for design guidance only and are not tested.

**Note 1:** The peripheral current is the sum of the base IDD or IPD and the additional current consumed when this peripheral is enabled. The peripheral  $\Delta$  current can be determined by subtracting the base IDD or IPD current from this limit. Max values should be used when calculating total current consumption.

**2:** The power-down current in Sleep mode does not depend on the oscillator type. Power-down current is measured with the part in Sleep mode, with all I/O pins in high-impedance state and tied to VDD.



## 22.5 DC Characteristics: PIC16F753-E (Extended)

DC CHARACTERISTICS		Standard Operating Conditions (unless otherwise stated) Operating temperature $-40^{\circ}\text{C} \leq T_A \leq +125^{\circ}\text{C}$ for extended					Conditions	
Param No.	Device Characteristics	Min.	Typ†	Max.	Units	V <sub>DD</sub>	Note	
							D020E	Power-down Base Current (IPD) <sup>(2)</sup> PIC16F753
—	0.3	TBD	μA	3.0				
—	0.5	TBD	μA	5.0				
D021E		—	3.0	TBD	μA	2.0	WDT Current <sup>(1)</sup>	
		—	4.0	TBD	μA	3.0		
		—	7.0	TBD	μA	5.0		
D022E		—	5.0	TBD	μA	3.0	BOR Current <sup>(1)</sup>	
		—	6.0	TBD	μA	5.0		
D023E		—	362	TBD	μA	2.0	CxSP = 1, Comparator Current <sup>(1)</sup> , single comparator enabled	
		—	418	TBD	μA	3.0		
		—	500	TBD	μA	5.0		
D024E		—	96	TBD	μA	2.0	CxSP = 0, Comparator Current <sup>(1)</sup> , single comparator enabled	
		—	112	TBD	μA	3.0		
		—	132	TBD	μA	5.0		
D025E		—	03	TBD	μA	3.0	A/D Current <sup>(1)</sup> , no conversion in progress	
		—	0.36	TBD	μA	5.0		
D026E		—	0.2	TBD	μA	3.0	DAC Current <sup>(1,3)</sup>	
		—	0.4	TBD	μA	5.0		
D027E		—	59	TBD	μA	3.0	FVR Current <sup>(1)</sup> , FVRBUFEN = 1, REFOUT buffer enabled	
		—	98	TBD	μA	5.0		

**Legend:** TBD = To Be Determined

\* These parameters are characterized but not tested.

† Data in "Typ" column is at 5.0V, 25°C unless otherwise stated. These parameters are for design guidance only and are not tested.

**Note 1:** The peripheral current is the sum of the base I<sub>DD</sub> or I<sub>PD</sub> and the additional current consumed when this peripheral is enabled. The peripheral Δ current can be determined by subtracting the base I<sub>DD</sub> or I<sub>PD</sub> current from this limit. Max values should be used when calculating total current consumption.

**2:** The power-down current in Sleep mode does not depend on the oscillator type. Power-down current is measured with the part in Sleep mode, with all I/O pins in high-impedance state and tied to V<sub>DD</sub>.

**3:** Both or one input reference are in high-Z state.

# PIC16F753/HV753

## 22.6 DC Characteristics: PIC16HV753-I (Industrial)

DC CHARACTERISTICS		Standard Operating Conditions (unless otherwise stated) Operating temperature $-40^{\circ}\text{C} \leq T_A \leq +85^{\circ}\text{C}$ for industrial					
Param. No.	Device Characteristics	Min.	Typ†	Max.	Units	Conditions	
						VDD	Note
D020	Power-down Base Current (IPD) <sup>(2,3)</sup> PIC16HV753	—	135	TBD	$\mu\text{A}$	2.0	WDT, BOR, Comparator, DAC and FVR disabled
		—	210	TBD	$\mu\text{A}$	3.0	
		—	260	TBD	$\mu\text{A}$	4.5	
D021		—	135	TBD	$\mu\text{A}$	2.0	WDT Current <sup>(1)</sup>
		—	210	TBD	$\mu\text{A}$	3.0	
		—	265	TBD	$\mu\text{A}$	4.5	
D022		—	215	TBD	$\mu\text{A}$	3.0	BOR Current <sup>(1)</sup>
		—	265	TBD	$\mu\text{A}$	4.5	
D023		—	362	TBD	$\mu\text{A}$	2.0	CxSP = 1, Comparator Current <sup>(1)</sup> , single comparator enabled
		—	418	TBD	$\mu\text{A}$	3.0	
		—	450	TBD	$\mu\text{A}$	4.5	
D024		—	90	TBD	$\mu\text{A}$	2.0	CxSP = 0, Comparator Current <sup>(1)</sup> , single comparator enabled
		—	107	TBD	$\mu\text{A}$	3.0	
		—	127	TBD	$\mu\text{A}$	4.5	
D025		—	210	TBD	$\mu\text{A}$	3.0	A/D Current <sup>(1)</sup> , no conversion in progress
		—	260	TBD	$\mu\text{A}$	4.5	
D026		—	215	TBD	$\mu\text{A}$	3.0	DAC Current <sup>(1)</sup>
		—	265	TBD	$\mu\text{A}$	4.5	
D027		—	485	TBD	$\mu\text{A}$	3.0	FVR Current <sup>(1)</sup> , FVRBUFEN = 1, REFOUT buffer enabled
		—	615	TBD	$\mu\text{A}$	4.5	

**Legend:** TBD = To Be Determined

\* These parameters are characterized but not tested.

† Data in "Typ" column is at 4.5V, 25°C unless otherwise stated. These parameters are for design guidance only and are not tested.

**Note 1:** The peripheral current is the sum of the base IDD or IPD and the additional current consumed when this peripheral is enabled. The peripheral  $\Delta$  current can be determined by subtracting the base IDD or IPD current from this limit. Max values should be used when calculating total current consumption.

**2:** The power-down current in Sleep mode does not depend on the oscillator type. Power-down current is measured with the part in Sleep mode, with all I/O pins in high-impedance state and tied to VDD.

**3:** Shunt regulator is always on and always draws operating current.

## 22.7 DC Characteristics: PIC16HV753-E (Extended)

DC CHARACTERISTICS		Standard Operating Conditions (unless otherwise stated) Operating temperature $-40^{\circ}\text{C} \leq T_A \leq +125^{\circ}\text{C}$ for extended					
Param. No.	Device Characteristics	Min.	Typ†	Max.	Units	Conditions	
						VDD	Note
D020E	Power-down Base Current (IPD) <sup>(2,3)</sup> PIC16HV753	—	135	TBD	$\mu\text{A}$	2.0	WDT, BOR, Comparator, DAC and FVR disabled
		—	210	TBD	$\mu\text{A}$	3.0	
		—	260	TBD	$\mu\text{A}$	4.5	
D021E		—	135	TBD	$\mu\text{A}$	2.0	WDT Current <sup>(1)</sup>
		—	210	TBD	$\mu\text{A}$	3.0	
		—	265	TBD	$\mu\text{A}$	4.5	
D022E		—	215	TBD	$\mu\text{A}$	3.0	BOR Current <sup>(1)</sup>
		—	265	TBD	$\mu\text{A}$	4.5	
D023E		—	185	TBD	$\mu\text{A}$	2.0	CxSP = 1, Comparator Current <sup>(1)</sup> , single comparator enabled
		—	265	TBD	$\mu\text{A}$	3.0	
		—	320	TBD	$\mu\text{A}$	4.5	
D024E		—	90	TBD	$\mu\text{A}$	2.0	CxSP = 0, Comparator Current <sup>(1)</sup> , single comparator enabled
		—	107	TBD	$\mu\text{A}$	3.0	
		—	127	TBD	$\mu\text{A}$	4.5	
D025E		—	210	TBD	$\mu\text{A}$	3.0	A/D Current <sup>(1)</sup> , no conversion in progress
		—	260	TBD	$\mu\text{A}$	4.5	
D026E		—	215	TBD	$\mu\text{A}$	3.0	DAC Current <sup>(1)</sup>
		—	265	TBD	$\mu\text{A}$	4.5	
D027E		—	485	TBD	$\mu\text{A}$	3.0	FVR Current <sup>(1)</sup> , FVRBUFEN = 1, REFOUT buffer enabled
		—	615	TBD	$\mu\text{A}$	4.5	

**Legend:** TBD = To Be Determined

\* These parameters are characterized but not tested.

† Data in "Typ" column is at 4.5V, 25°C unless otherwise stated. These parameters are for design guidance only and are not tested.

**Note 1:** The peripheral current is the sum of the base IDD or IPD and the additional current consumed when this peripheral is enabled. The peripheral  $\Delta$  current can be determined by subtracting the base IDD or IPD current from this limit. Max values should be used when calculating total current consumption.

**2:** The power-down current in Sleep mode does not depend on the oscillator type. Power-down current is measured with the part in Sleep mode, with all I/O pins in high-impedance state and tied to VDD.

**3:** Shunt regulator is always on and always draws operating current.

# PIC16F753/HV753

## 22.8 DC Characteristics: PIC16F753/HV753-I (Industrial) PIC16F753/HV753-E (Extended)

DC CHARACTERISTICS			Standard Operating Conditions (unless otherwise stated)				
			Operating temperature -40°C ≤ TA ≤ +85°C for industrial -40°C ≤ TA ≤ +125°C for extended				
Param. No.	Sym.	Characteristic	Min.	Typ†	Max.	Units	Conditions
D030 D030A D031 D040 D040A D041 D042	V <sub>IL</sub>	<b>Input Low Voltage</b>					
		I/O port: with TTL buffer	V <sub>SS</sub>	—	0.8	V	4.5V ≤ V <sub>DD</sub> ≤ 5.5V
		with Schmitt Trigger buffer	V <sub>SS</sub>	—	0.15 V <sub>DD</sub> 0.2 V <sub>DD</sub>	V	2.0V ≤ V <sub>DD</sub> ≤ 4.5V 2.0V ≤ V <sub>DD</sub> ≤ 5.5V
	V <sub>IH</sub>	<b>Input High Voltage</b>					
		I/O ports: with TTL buffer	2.0	—	V <sub>DD</sub>	V	4.5V ≤ V <sub>DD</sub> ≤ 5.5V
		with Schmitt Trigger buffer	0.25 V <sub>DD</sub> + 0.8	—	V <sub>DD</sub>	V	2.0V ≤ V <sub>DD</sub> ≤ 4.5V 2.0V ≤ V <sub>DD</sub> ≤ 5.5V
MCLR		0.8 V <sub>DD</sub>	—	V <sub>DD</sub>	V		
D060 D061 D063	I <sub>IL</sub>	<b>Input Leakage Current<sup>(1,2)</sup></b>					
		I/O ports	—	± 0.1	± 1	μA	V <sub>SS</sub> ≤ V <sub>PIN</sub> ≤ V <sub>DD</sub> , Pin at high-impedance
		RA3/MCLR <sup>(2,3)</sup>	—	± 0.7	± 5	μA	V <sub>SS</sub> ≤ V <sub>PIN</sub> ≤ V <sub>DD</sub>
D070*	IPUR	<b>PORTA Weak Pull-up Current<sup>(4)</sup></b>	50	250	400	μA	V <sub>DD</sub> = 5.0V, V <sub>PIN</sub> = V <sub>SS</sub>
D080	V <sub>OL</sub>	<b>Output Low Voltage</b>					
		I/O ports (excluding RA0, RA2)	—	—	0.6	V	I <sub>OL</sub> = 7.0 mA, V <sub>DD</sub> = 4.5V, -40°C to +125°C
			—	—	0.6	V	I <sub>OL</sub> = 8.5 mA, V <sub>DD</sub> = 4.5V, -40°C to +85°C
		RA0, RA2	—	—	0.6	V	I <sub>OL</sub> = 14 mA, V <sub>DD</sub> = 4.5V, -40°C to +125°C
			—	—	0.6	V	I <sub>OL</sub> = 17 mA, V <sub>DD</sub> = 4.5V, -40°C to +85°C
D090	V <sub>OH</sub>	<b>Output High Voltage</b>					
		I/O ports <sup>(4)</sup> (excluding RA0, RA2)	V <sub>DD</sub> - 0.7	—	—	V	I <sub>OH</sub> = -2.5 mA, V <sub>DD</sub> = 4.5V, -40°C to +125°C
			V <sub>DD</sub> - 0.7	—	—	V	I <sub>OH</sub> = -3.0 mA, V <sub>DD</sub> = 4.5V, -40°C to +85°C
		RA0, RA2	V <sub>DD</sub> - 0.7	—	—	V	I <sub>OH</sub> = -5.0 mA, V <sub>DD</sub> = 4.5V, -40°C to +125°C
			V <sub>DD</sub> - 0.7	—	—	V	I <sub>OH</sub> = -6.0 mA, V <sub>DD</sub> = 4.5V, -40°C to +85°C

\* These parameters are characterized but not tested.

† Data in "Typ" column is at 5.0V, 25°C unless otherwise stated. These parameters are for design guidance only and are not tested.

- Note**
- 1: Negative current is defined as current sourced by the pin.
  - 2: The leakage current on the MCLR pin is strongly dependent on the applied voltage level. The specified levels represent normal operating conditions. Higher leakage current may be measured at different input voltages.
  - 3: This specification applies to RA3/MCLR configured as RA3 with the internal weak pull-up disabled.
  - 4: This specification applies to all weak pull-up pins, including the weak pull-up found on RA3/MCLR. When RA3/MCLR is configured as MCLR Reset pin, the weak pull-up is always enabled.

## 22.8 DC Characteristics: PIC16F753/HV753-I (Industrial) PIC16F753/HV753-E (Extended) (Continued)

DC CHARACTERISTICS			Standard Operating Conditions (unless otherwise stated)				
			Operating temperature -40°C ≤ TA ≤ +85°C for industrial -40°C ≤ TA ≤ +125°C for extended				
Param. No.	Sym.	Characteristic	Min.	Typ†	Max.	Units	Conditions
D101*	CIO	<b>Capacitive Loading Specs on</b> All I/O pins	—	—	50	pF	
<b>Program Flash Memory</b>							
D130	EP	Cell Endurance	10K	100K	—	E/W	-40°C ≤ TA ≤ +85°C
D130A	ED	Cell Endurance	1K	10K	—	E/W	+85°C ≤ TA ≤ +125°C
D131	VPR	VDD for Read	V <sub>MIN</sub>	—	5.5	V	V <sub>MIN</sub> = Minimum operating voltage
D132	VPEW	VDD for Bulk Erase/Write	4.5	—	5.5	V	
D132A	VPEW	VDD for Row Erase/Write	V <sub>MIN</sub>	—	5.5	V	
D133	TPEW	Erase/Write cycle time	—	2	2.5	ms	
D134	TRETD	Characteristic Retention	40	—	—	Year	Provided no other specifications are violated

\* These parameters are characterized but not tested.

† Data in "Typ" column is at 5.0V, 25°C unless otherwise stated. These parameters are for design guidance only and are not tested.

- Note 1:** Negative current is defined as current sourced by the pin.
- Note 2:** The leakage current on the MCLR pin is strongly dependent on the applied voltage level. The specified levels represent normal operating conditions. Higher leakage current may be measured at different input voltages.
- Note 3:** This specification applies to RA3/MCLR configured as RA3 with the internal weak pull-up disabled.
- Note 4:** This specification applies to all weak pull-up pins, including the weak pull-up found on RA3/MCLR. When RA3/MCLR is configured as MCLR Reset pin, the weak pull-up is always enabled.

# PIC16F753/HV753

## 22.9 Thermal Considerations

Standard Operating Conditions (unless otherwise stated)					
Operating temperature $-40^{\circ}\text{C} \leq T_A \leq +125^{\circ}\text{C}$					
Param. No.	Sym.	Characteristic	Typ.	Units	Conditions
TH01	$\theta_{JA}$	Thermal Resistance Junction to Ambient	84.6*	C/W	8-pin PDIP package
			149.5*	C/W	8-pin SOIC package
			60*	C/W	8-pin DFN 3x3mm package
TH02	$\theta_{JC}$	Thermal Resistance Junction to Case	41.2*	C/W	8-pin PDIP package
			39.9*	C/W	8-pin SOIC package
			9*	C/W	8-pin DFN 3x3mm package
TH03	$T_{DIE}$	Die Temperature	150*	C	
TH04	PD	Power Dissipation	—	W	$PD = P_{INTERNAL} + P_{I/O}$
TH05	$P_{INTERNAL}$	Internal Power Dissipation	—	W	$P_{INTERNAL} = I_{DD} \times V_{DD}$ <b>(NOTE 1)</b>
TH06	$P_{I/O}$	I/O Power Dissipation	—	W	$P_{I/O} = \sum (I_{OL} \times V_{OL}) + \sum (I_{OH} \times (V_{DD} - V_{OH}))$
TH07	$P_{DER}$	Derated Power	—	W	$P_{DER} = P_{D_{MAX}} (T_{DIE} - T_A) / \theta_{JA}$ <b>(NOTE 2)</b>

\* These parameters are characterized but not tested.

**Note 1:**  $I_{DD}$  is current to run the chip alone without driving any load on the output pins.

**2:**  $T_A$  = Ambient temperature.

PRELIMINARY

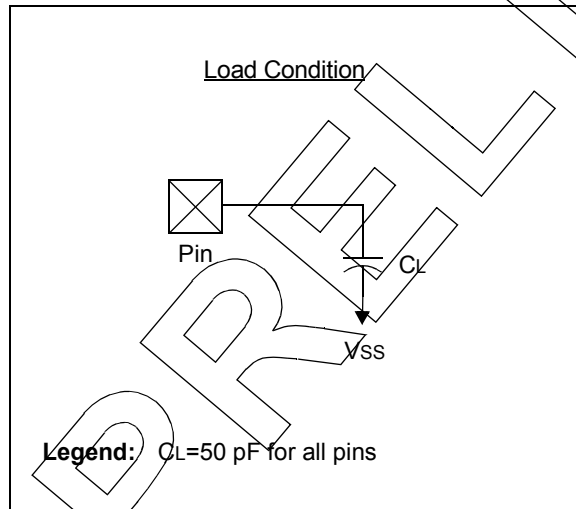
## 22.10 Timing Parameter Symbology

The timing parameter symbols have been created with one of the following formats:

1. TppS2ppS
2. TppS

<b>T</b>	F      Frequency	T      Time
Lowercase letters (pp) and their meanings:		
<b>pp</b>	cc      CCP1 ck      CLKOUT cs $\overline{CS}$ di      SDI do      SDO dt      Data in io      I/O Port mc      MCLR	osc      OSC1 rd $\overline{RD}$ rw $\overline{RD}$ or $\overline{WR}$ sc      SCK ss $\overline{SS}$ t0      T0CKI t1      T1CKI wr $\overline{WR}$
Uppercase letters and their meanings:		
<b>S</b>	F      Fall H      High I      Invalid (High-Impedance) L      Low	P      Period R      Rise V      Valid Z      High-Impedance

**FIGURE 22-3: LOAD CONDITIONS**



# PIC16F753/HV753

## 22.11 AC Characteristics: PIC16F753/HV753 (Industrial, Extended)

FIGURE 22-4: CLOCK TIMING

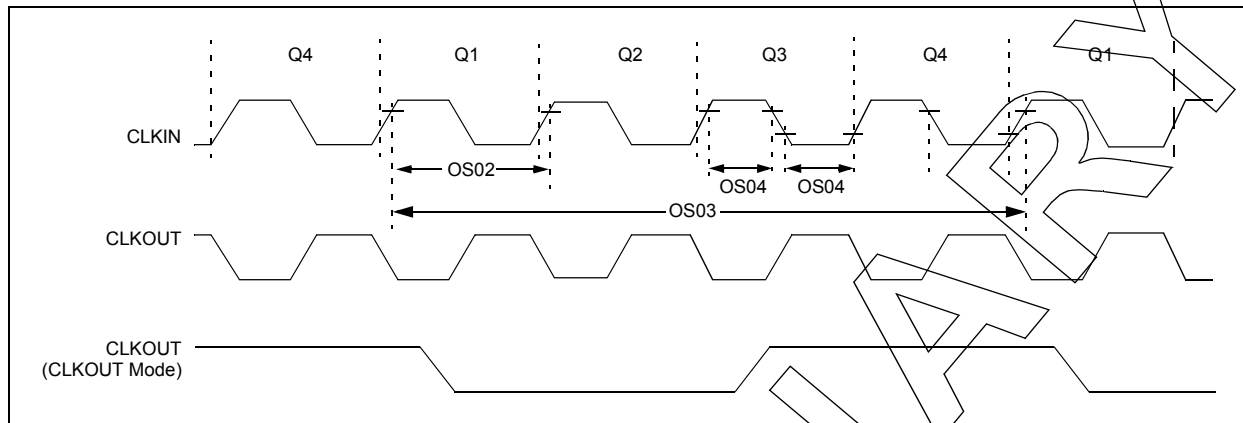


TABLE 22-1: CLOCK OSCILLATOR TIMING REQUIREMENTS

Standard Operating Conditions (unless otherwise stated)							
		Operating temperature $-40^{\circ}\text{C} \leq T_A \leq +125^{\circ}\text{C}$					
Param. No.	Sym.	Characteristic	Min.	Typ†	Max.	Units	Conditions
OS01	Fosc	External CLKIN Frequency <sup>(1)</sup>	DC	—	20	MHz	EC Oscillator
OS02	Tosc	External CLKIN Period <sup>(1)</sup>	50	—	$\infty$	ns	EC Oscillator
OS03	Tcy	Instruction Cycle Time <sup>(1)</sup>	200	Tcy	DC	ns	Tcy = 4/Fosc

\* These parameters are characterized but not tested.

† Data in "Typ" column is at 5V, 25°C unless otherwise stated. These parameters are for design guidance only and are not tested.

**Note 1:** Instruction cycle period (Tcy) equals four times the input oscillator time base period. All specified values are based on characterization data for that particular oscillator type under standard operating conditions with the device executing code. Exceeding these specified limits may result in an unstable oscillator operation and/or higher than expected current consumption. All devices are tested to operate at "min" values with an external clock applied to CLKIN pin. When an external clock input is used, the "max" cycle time limit is "DC" (no clock) for all devices.



**TABLE 22-2: OSCILLATOR PARAMETERS**

Standard Operating Conditions (unless otherwise stated)								
Operating Temperature $-40^{\circ}\text{C} \leq T_A \leq +125^{\circ}\text{C}$								
Param. No.	Sym.	Characteristic	Freq. Tolerance	Min.	Typ†	Max.	Units	Conditions
OS06	TWARM	Internal Oscillator Switch when running <sup>(2)</sup>	—	—	—	2	Tosc	Slowest clock
OS07	INTosc	Internal Calibrated INTOSC Frequency <sup>(1)</sup> (4 MHz)	$\pm 1\%$	3.96	4.0	4.04	MHz	$V_{DD} = 3.5\text{V}, T_A = 25^{\circ}\text{C}$ $2.5\text{V} \leq V_{DD} \leq 5.5\text{V}, 0^{\circ}\text{C} \leq T_A \leq +85^{\circ}\text{C}$ $2.0\text{V} \leq V_{DD} \leq 5.5\text{V}, -40^{\circ}\text{C} \leq T_A \leq +85^{\circ}\text{C (Ind.)}, -40^{\circ}\text{C} \leq T_A \leq +125^{\circ}\text{C (Ext.)}$
			$\pm 2\%$	3.92	4.0	4.08	MHz	
			$\pm 5\%$	3.80	4.0	4.2	MHz	
OS08	INTosc	Internal Calibrated INTOSC Frequency <sup>(1)</sup> (8 MHz)	$\pm 1\%$	7.92	8.0	8.08	MHz	$V_{DD} = 3.5\text{V}, T_A = 25^{\circ}\text{C}$ $2.5\text{V} \leq V_{DD} \leq 5.5\text{V}, 0^{\circ}\text{C} \leq T_A \leq +85^{\circ}\text{C}$ $2.0\text{V} \leq V_{DD} \leq 5.5\text{V}, -40^{\circ}\text{C} \leq T_A \leq +85^{\circ}\text{C (Ind.)}, -40^{\circ}\text{C} \leq T_A \leq +125^{\circ}\text{C (Ext.)}$
			$\pm 2\%$	7.84	8.0	8.16	MHz	
			$\pm 5\%$	7.60	8.0	8.40	MHz	
OS10*	Tiosc ST	INTOSC Oscillator Wake-up from Sleep Start-up Time	—	TBD	12	TBD	$\mu\text{s}$	$V_{DD} = 2.0\text{V}, -40^{\circ}\text{C to } +85^{\circ}\text{C}$ $V_{DD} = 3.0\text{V}, -40^{\circ}\text{C to } +85^{\circ}\text{C}$ $V_{DD} = 5.0\text{V}, -40^{\circ}\text{C to } +85^{\circ}\text{C}$
			—	TBD	7	TBD	$\mu\text{s}$	
			—	TBD	6	TBD	$\mu\text{s}$	

**Legend:** TBD = To Be Determined

\* These parameters are characterized but not tested.

† Data in "Typ" column is at 5.0V, 25°C unless otherwise stated. These parameters are for design guidance only and are not tested.

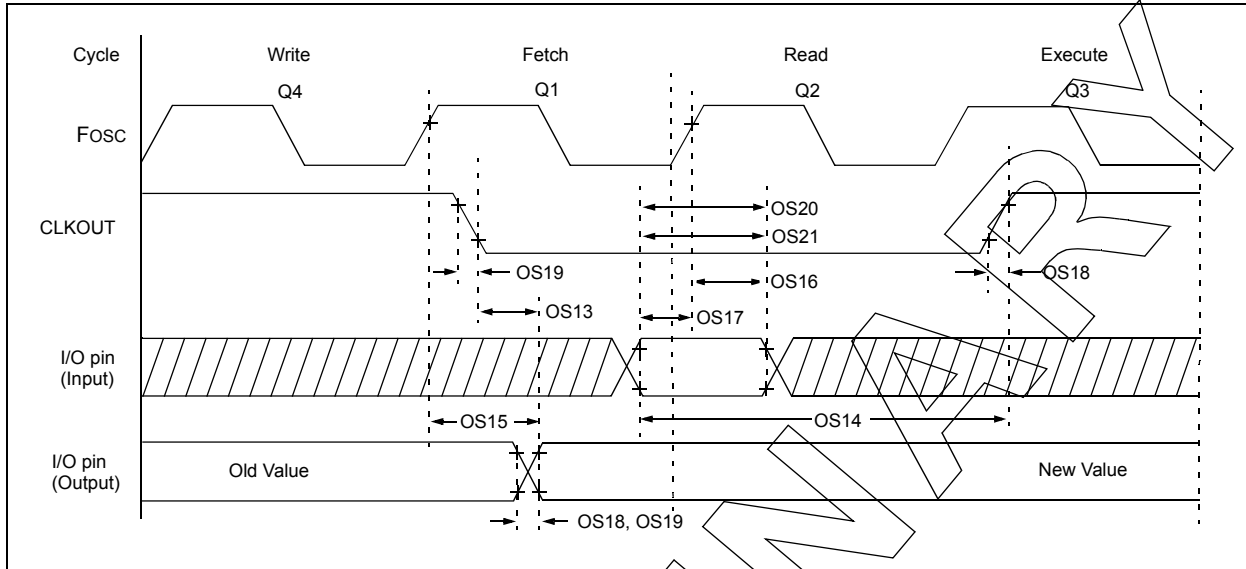
**Note 1:** To ensure these oscillator frequency tolerances,  $V_{DD}$  and  $V_{SS}$  must be capacitively decoupled as close to the device as possible. 0.1  $\mu\text{F}$  and 0.01  $\mu\text{F}$  values in parallel are recommended.

**2:** By design.

PRELIMINARY

# PIC16F753/HV753

**FIGURE 22-5: CLKOUT AND I/O TIMING**



**TABLE 22-3: CLKOUT AND I/O TIMING PARAMETERS**

Standard Operating Conditions (unless otherwise stated) Operating Temperature $-40^{\circ}\text{C} \leq T_A \leq +125^{\circ}\text{C}$							
Param. No.	Sym.	Characteristic	Min.	Typ†	Max.	Units	Conditions
OS13	TckL2ioV	CLKOUT $\downarrow$ to Port out valid <sup>(2)</sup>	—	—	20	ns	
OS14	TioV2ckH	Port input valid before CLKOUT $\uparrow$ <sup>(2)</sup>	Tosc + 200 ns	—	—	ns	
OS15	Tosh2ioV	Fosc $\uparrow$ (Q1 cycle) to Port out valid	—	50	70*	ns	VDD = 5.0V
OS16	Tosh2ioI	Fosc $\uparrow$ (Q2 cycle) to Port input invalid (I/O in hold time)	50	—	—	ns	VDD = 5.0V
OS17	TioV2osH	Port input valid to Fosc $\uparrow$ (Q2 cycle) (I/O in setup time)	20	—	—	ns	
OS18	TioR	Port output rise time <sup>(2)</sup>	—	15 40	72 32	ns	VDD = 2.0V VDD = 5.0V
OS19	TioF	Port output fall time <sup>(2)</sup>	—	28 15	55 30	ns	VDD = 2.0V VDD = 5.0V
OS20*	TINP	INT pin input high or low time	25	—	—	ns	
OS21*	TRAP	PORTA interrupt-on-change new input level time	Tcy <sup>(1)</sup>	—	—	ns	

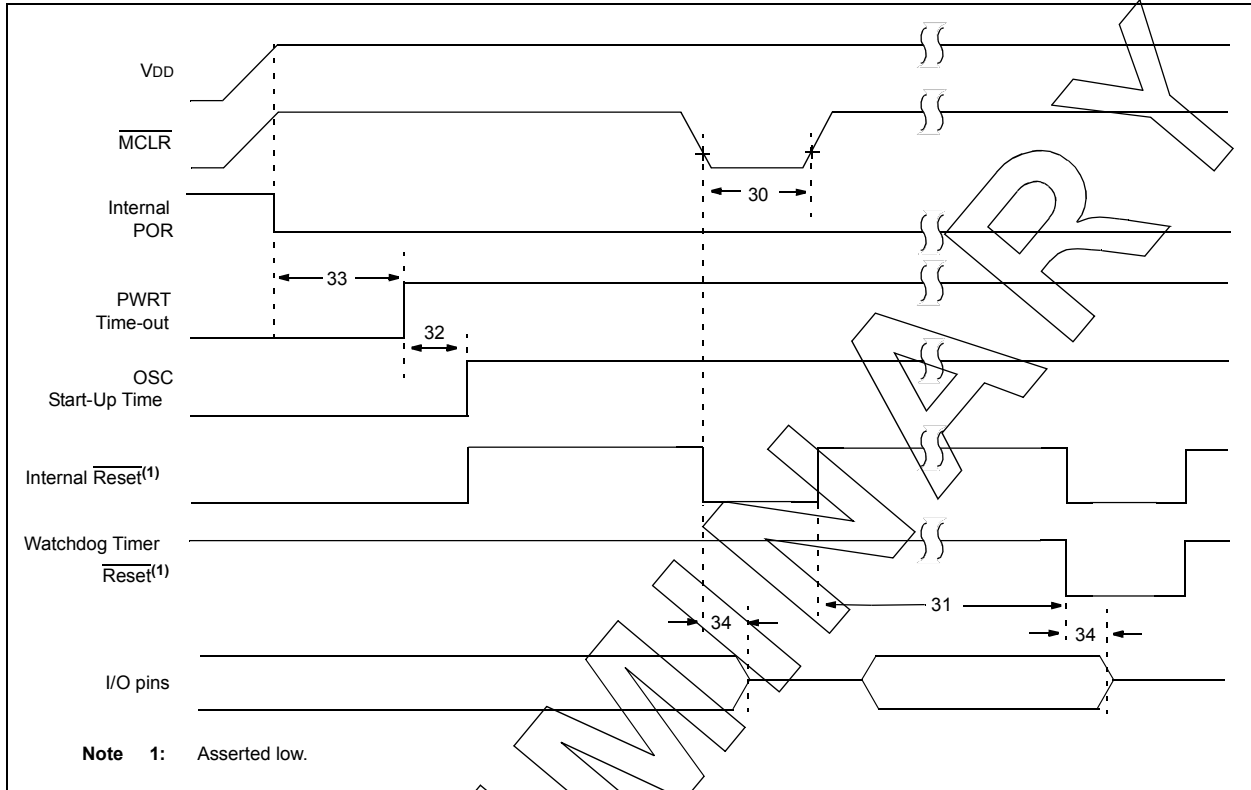
These parameters are characterized but not tested.

† Data in "Typ" column is at 5.0V, 25°C unless otherwise stated.

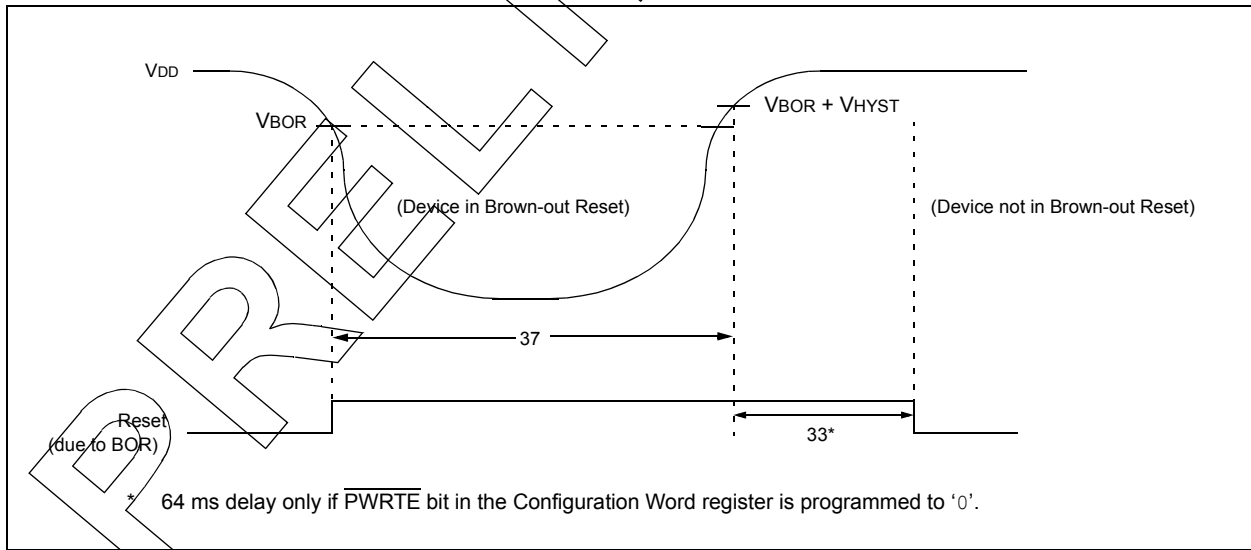
**Note 1:** Instruction cycle period (Tcy) equals four times the input oscillator time base period. All specified values are based on characterization data for that particular oscillator type under standard operating conditions with the device executing code. Exceeding these specified limits may result in an unstable oscillator operation and/or higher than expected current consumption. All devices are tested to operate at "min" values with an external clock applied to the CLKIN pin. When an external clock input is used, the "max" cycle time limit is "DC" (no clock) for all devices.

**2:** Includes  $\overline{\text{CLKOUTEN}} = 0$ , CLKOUT function enabled.

**FIGURE 22-6: RESET, WATCHDOG TIMER, AND POWER-UP TIMER TIMING**



**FIGURE 22-7: BROWN-OUT RESET TIMING AND CHARACTERISTICS**



# PIC16F753/HV753

**TABLE 22-4: RESET, WATCHDOG TIMER, OSCILLATOR START-UP TIMER, POWER-UP TIMER AND BROWN-OUT RESET PARAMETERS**

Standard Operating Conditions (unless otherwise stated)							
Operating Temperature $-40^{\circ}\text{C} \leq T_A \leq +125^{\circ}\text{C}$							
Param. No.	Sym.	Characteristic	Min.	Typ†	Max.	Units	Conditions
30	TMCL	MCLR Pulse Width (low)	2	—	—	$\mu\text{s}$	$V_{DD} = 5\text{V}, -40^{\circ}\text{C to } +85^{\circ}\text{C}$
			5	—	—	$\mu\text{s}$	$V_{DD} = 5\text{V}, -40^{\circ}\text{C to } +125^{\circ}\text{C}$
31*	TWDT	Watchdog Timer Time-out Period (No Prescaler)	10	20	TBD	ms	$V_{DD} = 5\text{V}, -40^{\circ}\text{C to } +85^{\circ}\text{C}$
			10	20	TBD	ms	$V_{DD} = 5\text{V}, -40^{\circ}\text{C to } +125^{\circ}\text{C}$
32*	TPWRT	Power-up Timer Period	40	65	140	ms	
33*	TIOZ	I/O High-impedance from MCLR Low or Watchdog Timer Reset	—	—	2.0	$\mu\text{s}$	
34	VBOR	Brown-out Reset Voltage	2.0	2.15	2.3	V	(NOTE 1)
35*	VHYST	Brown-out Reset Hysteresis	—	100	—	mV	
36*	TBOR	Brown-out Reset Minimum Detection Period	100	—	—	$\mu\text{s}$	$V_{DD} \leq V_{BOR}$

**Legend:** TBD = To Be Determined

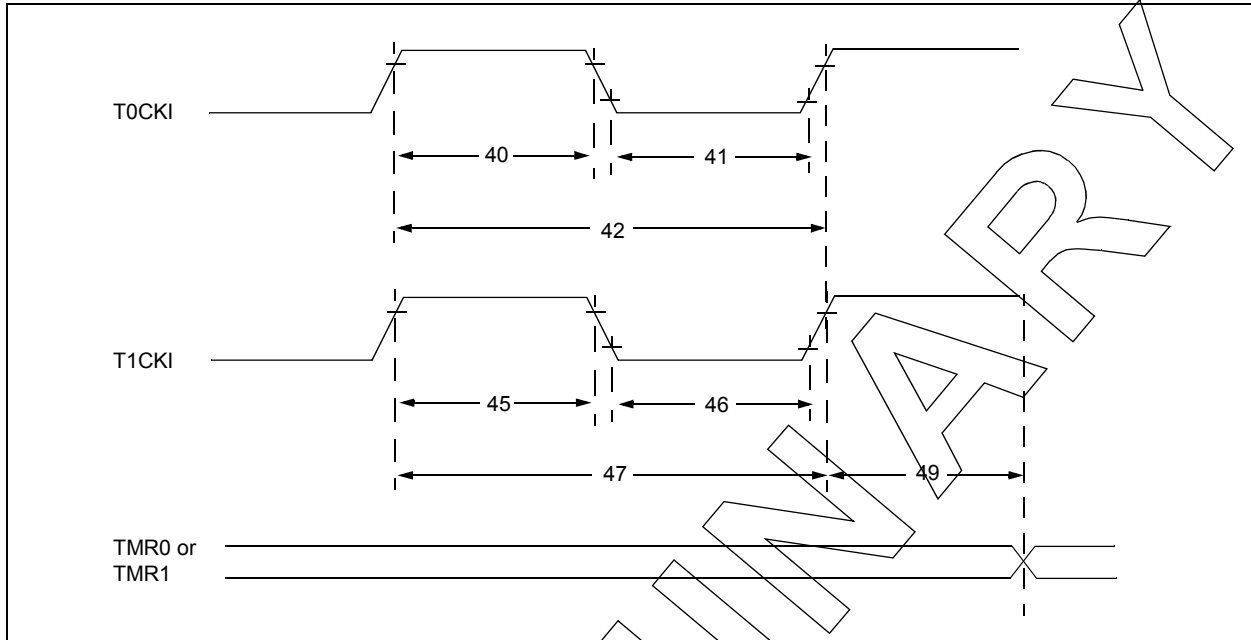
\* These parameters are characterized but not tested.

† Data in "Typ" column is at 5V, 25°C unless otherwise stated. These parameters are for design guidance only and are not tested.

**Note 1:** To ensure these voltage tolerances,  $V_{DD}$  and  $V_{SS}$  must be capacitively decoupled as close to the device as possible. 0.1  $\mu\text{F}$  and 0.01  $\mu\text{F}$  values in parallel are recommended.

PRELIMINARY

**FIGURE 22-8: TIMER0 AND TIMER1 EXTERNAL CLOCK TIMINGS**



**TABLE 22-5: TIMER0 AND TIMER1 EXTERNAL CLOCK REQUIREMENTS**

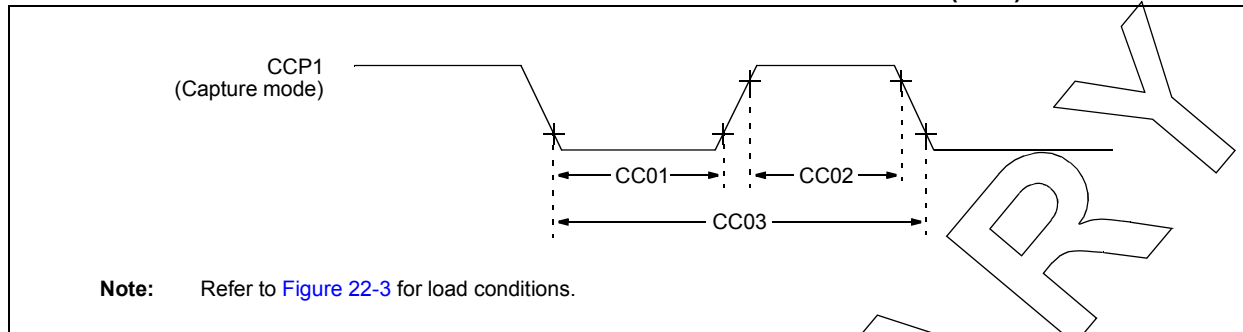
Standard Operating Conditions (unless otherwise stated)								
Operating Temperature $-40^{\circ}\text{C} \leq T_A \leq +125^{\circ}\text{C}$								
Param. No.	Sym.	Characteristic		Min.	Typ†	Max.	Units	Conditions
40*	Tt0H	T0CKI High Pulse Width	No Prescaler	$0.5 T_{CY} + 20$	—	—	ns	
			With Prescaler	10	—	—	ns	
41*	Tt0L	T0CKI Low Pulse Width	No Prescaler	$0.5 T_{CY} + 20$	—	—	ns	
			With Prescaler	10	—	—	ns	
42*	Tt0P	T0CKI Period		Greater of: $20$ or $\frac{T_{CY} + 40}{N}$	—	—	ns	N = prescale value (2, 4, ..., 256)
45*	Tt1H	T1CKI High Time	Synchronous, No Prescaler	$0.5 T_{CY} + 20$	—	—	ns	
			Synchronous, with Prescaler	15	—	—	ns	
			Asynchronous	30	—	—	ns	
46*	Tt1L	T1CKI Low Time	Synchronous, No Prescaler	$0.5 T_{CY} + 20$	—	—	ns	
			Synchronous, with Prescaler	15	—	—	ns	
			Asynchronous	30	—	—	ns	
47*	Tt1P	T1CKI Input Period	Synchronous	Greater of: $30$ or $\frac{T_{CY} + 40}{N}$	—	—	ns	N = prescale value (1, 2, 4, 8)
			Asynchronous	60	—	—	ns	
49*	TCKEZTMR1	Delay from External Clock Edge to Timer Increment		$2 T_{osc}$	—	$7 T_{osc}$	—	Timers in Sync mode

\* These parameters are characterized but not tested.

† Data in "Typ" column is at 5V, 25°C unless otherwise stated. These parameters are for design guidance only and are not tested.

# PIC16F753/HV753

**FIGURE 22-9: PIC16F753/HV753 CAPTURE/COMPARE/PWM TIMINGS (CCP)**



**TABLE 22-6: PIC16F753/HV753 CAPTURE/COMPARE/PWM REQUIREMENTS (CCP)**

Standard Operating Conditions (unless otherwise stated)								
Operating Temperature $-40^{\circ}\text{C} \leq T_A \leq +125^{\circ}\text{C}$								
Param. No.	Sym.	Characteristic		Min.	Typ†	Max.	Units	Conditions
CC01*	TccL	CCP1 Input Low Time	No Prescaler	$0.5T_{CY} + 20$	—	—	ns	
			With Prescaler	20	—	—	ns	
CC02*	TccH	CCP1 Input High Time	No Prescaler	$0.5T_{CY} + 20$	—	—	ns	
			With Prescaler	20	—	—	ns	
CC03*	TccP	CCP1 Input Period		$\frac{3T_{CY} + 40}{N}$	—	—	ns	N = prescale value (1, 4 or 16)

\* These parameters are characterized but not tested.

† Data in "Typ" column is at 5V, 25°C unless otherwise stated. These parameters are for design guidance only and are not tested.

**TABLE 22-7: COMPARATOR SPECIFICATIONS**

Standard Operating Conditions (unless otherwise stated)								
Operating Temperature $-40^{\circ}\text{C} \leq T_A \leq +125^{\circ}\text{C}$								
Param. No.	Sym.	Characteristics		Min.	Typ†	Max.	Units	Comments
CM01	V <sub>OS</sub>	Input Offset Voltage <sup>(2)</sup>		—	$\pm 5.0$	$\pm 10$	mV	CxSP = 1
				—	$\pm 7.0$	$\pm 20$	mV	CxSP = 0
CM02	V <sub>CM</sub>	Input Common Mode Voltage		0	—	$V_{DD} - 1.5$	V	
CM03*	CMRR	Common Mode Rejection Ratio		+55	—	—	dB	
CM04*	T <sub>RT</sub>	Response Time <sup>(1)</sup>		CxSP = 1	—	55	TBD	ns
				CxSP = 0	—	65	TBD	ns
CM05*	T <sub>MC2COV</sub>	Comparator Mode Change to Output Valid		—	—	10	μs	
CM06*	V <sub>HYS</sub>	Input Hysteresis Voltage		—	20	TBD	mV	

**Legend:** TBD = To Be Determined

\* These parameters are characterized but not tested.

† Data in "Typ" column is at 5V, 25°C unless otherwise stated. These parameters are for design guidance only and are not tested.

**Note 1:** Response time is measured with one comparator input at  $(V_{DD} - 1.5)/2 - 100\text{ mV}$  to  $(V_{DD} - 1.5)/2 + 20\text{ mV}$ . The other input is at  $(V_{DD} - 1.5)/2$ .

**Note 2:** Input offset voltage is measured with one comparator input at  $(V_{DD} - 1.5V)/2$ .

**TABLE 22-8: DIGITAL-TO-ANALOG (DAC) SPECIFICATIONS**

Standard Operating Conditions (unless otherwise stated) Operating temperature $-40^{\circ}\text{C} \leq T_A \leq +125^{\circ}\text{C}$							
Param. No.	Sym.	Characteristics	Min.	Typ†	Max.	Units	Comments
DA01*	CLSB	Step Size	—	$V_{DD}/512$	—	V	
DA02*	CACC	Absolute Accuracy	—	$\pm 1/2$	—	LSB	
DA03*	CR	Unit Resistor Value (R)	—	TBD	—	$\Omega$	
DA04*	CST	Settling Time	—	10	—	$\mu\text{s}$	

**Legend:** TBD = To Be Determined

\* These parameters are characterized but not tested.

† Data in "Typ" column is at 5V, 25°C unless otherwise stated. These parameters are for design guidance only and are not tested.

**TABLE 22-9: FIXED VOLTAGE REFERENCE SPECIFICATIONS**

VR Voltage Reference Specifications			Standard Operating Conditions (unless otherwise stated) Operating temperature $-40^{\circ}\text{C} \leq T_A \leq +125^{\circ}\text{C}$				
Param. No.	Symbol	Characteristics	Min.	Typ.	Max.	Units	Comments
VR01*	VFVR	FVR Voltage Output	—	1.2	—	V	
VR02*	TSTABLE	FVR Turn On Time	—	200	—	$\mu\text{s}$	

\* These parameters are characterized but not tested.

**TABLE 22-10: SHUNT REGULATOR SPECIFICATIONS (PIC16HV753 only)**

SHUNT REGULATOR CHARACTERISTICS			Standard Operating Conditions (unless otherwise stated) Operating temperature $-40^{\circ}\text{C} \leq T_A \leq +125^{\circ}\text{C}$				
Param. No.	Symbol	Characteristics	Min.	Typ.	Max.	Units	Comments
SR01	VSHUNT	Shunt Voltage	4.75	5	5.4	V	
SR02	ISHUNT	Shunt Current	1	—	50	mA	
SR03*	TSETTLE	Settling Time	—	—	150	ns	To 1% of final value
SR04	CLOAD	Load Capacitance	0.01	—	10	$\mu\text{F}$	Bypass capacitor on VDD pin
SR05	$\Delta I_{SNT}$	Regulator operating current	—	180	—	$\mu\text{A}$	Includes band gap reference current

\* These parameters are characterized but not tested.

# PIC16F753/HV753

**TABLE 22-11: OPERATIONAL AMPLIFIER SPECIFICATIONS**

OP AMP CHARACTERISTICS			Standard Operating Conditions (unless otherwise stated) Operating temperature 25°C, High-Power mode, VDD = 5V				
Param. No.	Symbol	Characteristics	Min.	Typ.	Max.	Units	Conditions
OPA01	GBWP	Gain bandwidth product	—	3	—	MHz	
OPA02	TON	Turn on time	—	10	—	μs	
OPA03	PM	Phase margin	—	60	—	°C	
OPA04	SR	Slew rate	2	—	—	V/μs	
OPA05	OFF	Offset	—	—	—	mV	
OPA06	CMRR	Common mode rejection ratio	—	70	—	dB	
OPA07	AOL	Open loop gain	—	—	90	dB	No Load
					60	dB	Standard Load
OPA08	V <sub>ICM</sub>	Common mode input range	V <sub>SS</sub>	—	AVDD - 1.4V	V	
OPA09	PSRR	Power supply rejection ratio	80	—	—	dB	

PRELIMINARY



**TABLE 22-12: PIC16F753/HV753 A/D CONVERTER (ADC) CHARACTERISTICS:**

Standard Operating Conditions (unless otherwise stated)							
Operating temperature $-40^{\circ}\text{C} \leq T_A \leq +125^{\circ}\text{C}$							
Param. No.	Sym.	Characteristic	Min.	Typ†	Max.	Units	Conditions
AD01	NR	Resolution	—	—	10 bits	bit	
AD02	EIL	Integral Error <sup>(1)</sup>	—	—	$\pm 1$	LSb	$V_{\text{REF}} = 5.12\text{V}^{(5)}$
AD03	EDL	Differential Error <sup>(1,2)</sup>	—	—	$\pm 1$	LSb	No missing codes to 10 bits $V_{\text{REF}} = 5.12\text{V}^{(5)}$
AD04	EOFF	Offset Error <sup>(1)</sup>	—	+1.5	+2.0	LSb	$V_{\text{REF}} = 5.12\text{V}^{(5)}$
AD07	EGN	Gain Error <sup>(1)</sup>	—	—	$\pm 1$	LSb	$V_{\text{REF}} = 5.12\text{V}^{(5)}$
AD06 AD06A	VREF	Reference Voltage <sup>(3)</sup>	2.2 2.5	—	— VDD	V	Absolute minimum to ensure 1 LSb accuracy
AD07	VAIN	Full-Scale Range	VSS	—	VREF	V	
AD08	ZAIN	Recommended Impedance of Analog Voltage Source	—	—	10	k $\Omega$	
AD09*	IREF	VREF Input Current <sup>(3,4)</sup>	10	—	1000	$\mu\text{A}$	During VAIN acquisition. Based on differential of V <sub>HOLD</sub> to VAIN.
			—	—	50 <sup>(4)</sup>	$\mu\text{A}$	During A/D conversion cycle

\* These parameters are characterized but not tested.

† Data in "Typ" column is at 5.0V, 25°C unless otherwise stated. These parameters are for design guidance only and are not tested.

**Note 1:** Total Absolute Error includes integral, differential, offset and gain errors.

**2:** The A/D conversion result never decreases with an increase in the input voltage and has no missing codes.

**3:** ADC VREF is from external VREF or VDD pin, whichever is selected as reference input.

**4:** When ADC is off, it will not consume any current other than leakage current. The power-down current specification includes any such leakage from the ADC module.

**5:** VREF = 5V for PIC16HV753.

PRELIMINARY

# PIC16F753/HV753

**TABLE 22-13: PIC16F753/HV753 A/D CONVERSION REQUIREMENTS**

Standard Operating Conditions (unless otherwise stated) Operating temperature $-40^{\circ}\text{C} \leq T_A \leq +125^{\circ}\text{C}$							
Param. No.	Sym.	Characteristic	Min.	Typ†	Max.	Units	Conditions
AD130*	TAD	A/D Clock Period	1.6	—	9.0	$\mu\text{s}$	TOSC-based, $V_{\text{REF}} \geq 3.0\text{V}$
			3.0	—	9.0	$\mu\text{s}$	TOSC-based, $V_{\text{REF}}$ full range <sup>(3)</sup>
		A/D Internal RC Oscillator Period	3.0	6.0	9.0	$\mu\text{s}$	$\text{ADCS}\langle 2:0 \rangle = 11$ At $V_{\text{DD}} = 2.5\text{V}$
			1.6	4.0	6.0	$\mu\text{s}$	At $V_{\text{DD}} = 5.0\text{V}$
AD131	TCNV	Conversion Time (not including Acquisition Time) <sup>(1)</sup>	—	11	—	TAD	Set GO/DONE bit to new data in A/D Result register
AD132*	TACQ	Acquisition Time <sup>(2)</sup>	—	11.5	—	$\mu\text{s}$	
AD133*	TAMP	Amplifier Settling Time	—	—	5	$\mu\text{s}$	
AD134	TGO	Q4 to A/D Clock Start	—	Tosc/2	—	—	

\* These parameters are characterized but not tested.

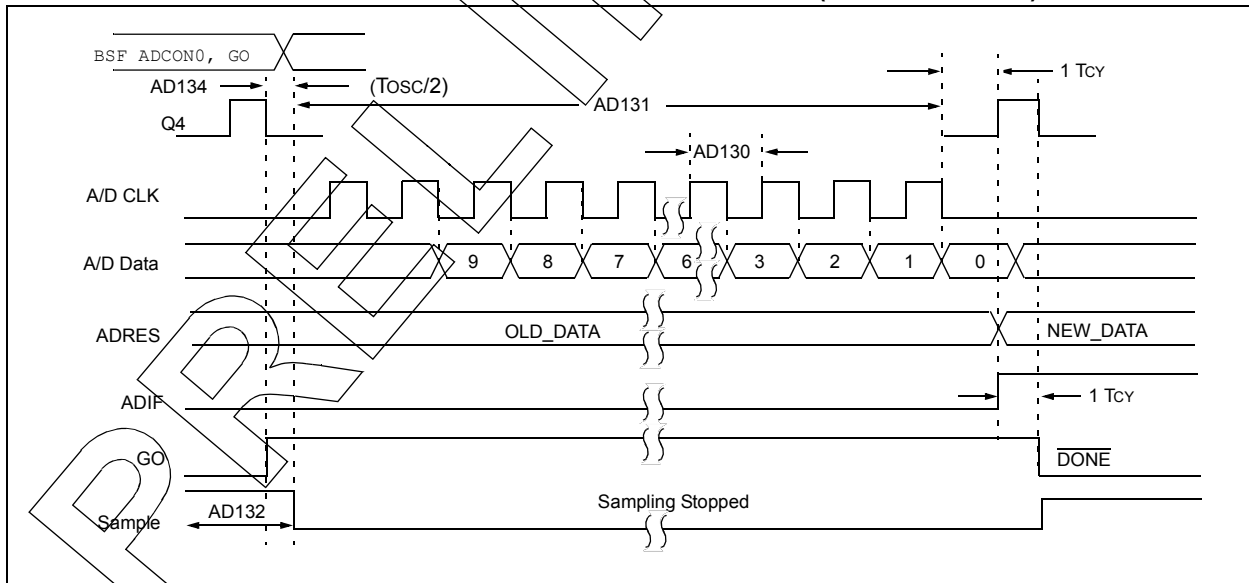
† Data in "Typ" column is at 5.0V, 25°C unless otherwise stated. These parameters are for design guidance only and are not tested.

**Note 1:** ADRESH and ADRESL registers may be read on the following Tcy cycle.

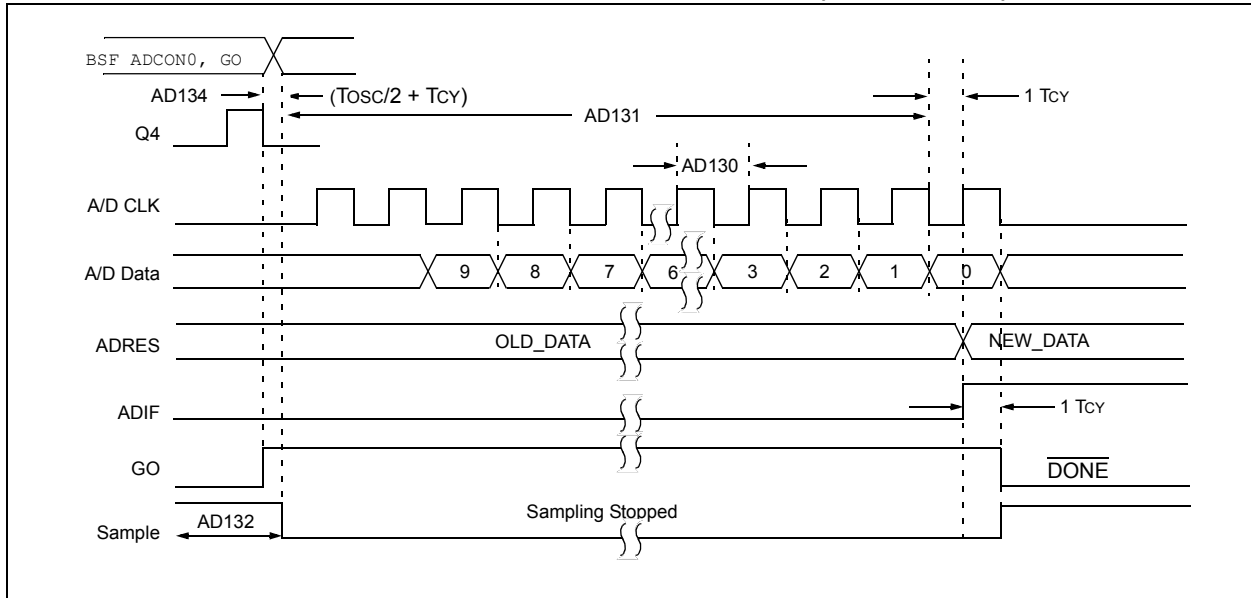
**Note 2:** See [Section 12.4 "A/D Acquisition Requirements"](#) for minimum conditions.

**Note 3:** Full range for PIC16HV753 powered by the shunt regulator is the 5V regulated voltage.

**FIGURE 22-10: PIC16F753/HV753 A/D CONVERSION TIMING (NORMAL MODE)**



**FIGURE 22-11: PIC16F753/HV753 A/D CONVERSION TIMING (SLEEP MODE)**



# PIC16F753/HV753

---

NOTES:

## 23.0 DC AND AC CHARACTERISTICS GRAPHS AND CHARTS

Graphs and charts are not available at this time.

# PIC16F753/HV753

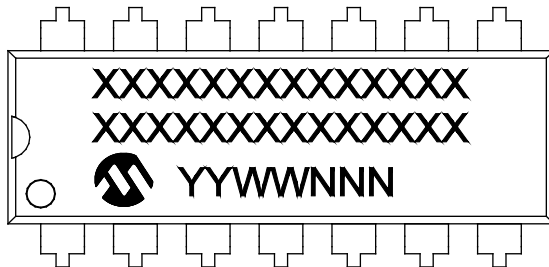
---

NOTES:

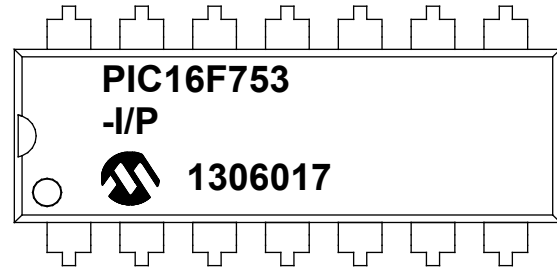
## 24.0 PACKAGING INFORMATION

### 24.1 Package Marking Information

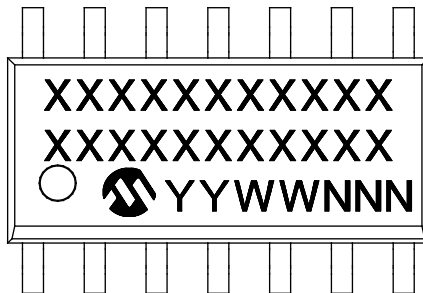
14-Lead PDIP (300 mil)



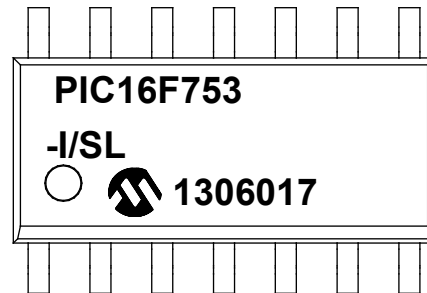
Example



14-Lead SOIC (3.90 mm)



Example



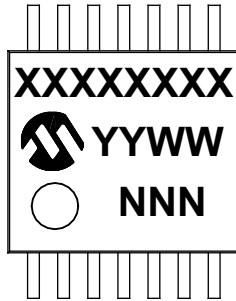
<b>Legend:</b>	XX...X	Customer-specific information
	Y	Year code (last digit of calendar year)
	YY	Year code (last 2 digits of calendar year)
	WW	Week code (week of January 1 is week '01')
	NNN	Alphanumeric traceability code
	(e3)	Pb-free JEDEC designator for Matte Tin (Sn)
	*	This package is Pb-free. The Pb-free JEDEC designator ( ) can be found on the outer packaging for this package. (e3)
<b>Note:</b>	In the event the full Microchip part number cannot be marked on one line, it will be carried over to the next line, thus limiting the number of available characters for customer-specific information.	

\* Standard PIC device marking consists of Microchip part number, year code, week code, and traceability code. For PIC device marking beyond this, certain price adders apply. Please check with your Microchip Sales Office. For QTP devices, any special marking adders are included in QTP price.

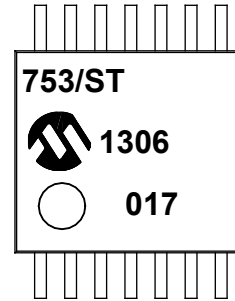
# PIC16F753/HV753

## 24.2 Package Marking Information

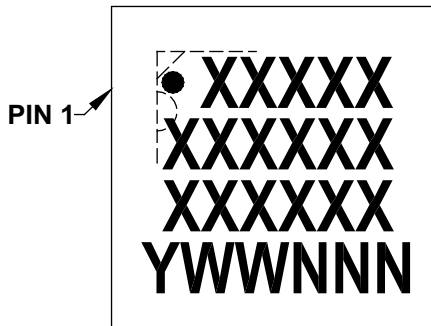
14-Lead TSSOP (4.4 mm)



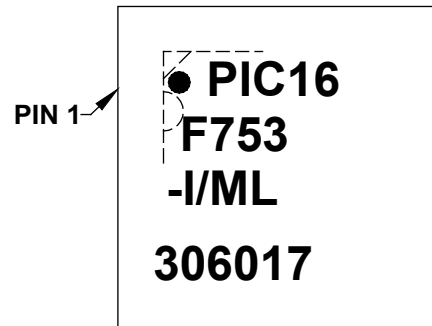
Example



16-Lead QFN (4x4x0.9 mm)



Example



<b>Legend:</b>	XX...X	Customer-specific information
	Y	Year code (last digit of calendar year)
	YY	Year code (last 2 digits of calendar year)
	WW	Week code (week of January 1 is week '01')
	NNN	Alphanumeric traceability code
	(e3)	Pb-free JEDEC designator for Matte Tin (Sn)
	*	This package is Pb-free. The Pb-free JEDEC designator ( ) (e3) can be found on the outer packaging for this package.
<b>Note:</b>	In the event the full Microchip part number cannot be marked on one line, it will be carried over to the next line, thus limiting the number of available characters for customer-specific information.	

\* Standard PIC device marking consists of Microchip part number, year code, week code, and traceability code. For PIC device marking beyond this, certain price adders apply. Please check with your Microchip Sales Office. For QTP devices, any special marking adders are included in QTP price.

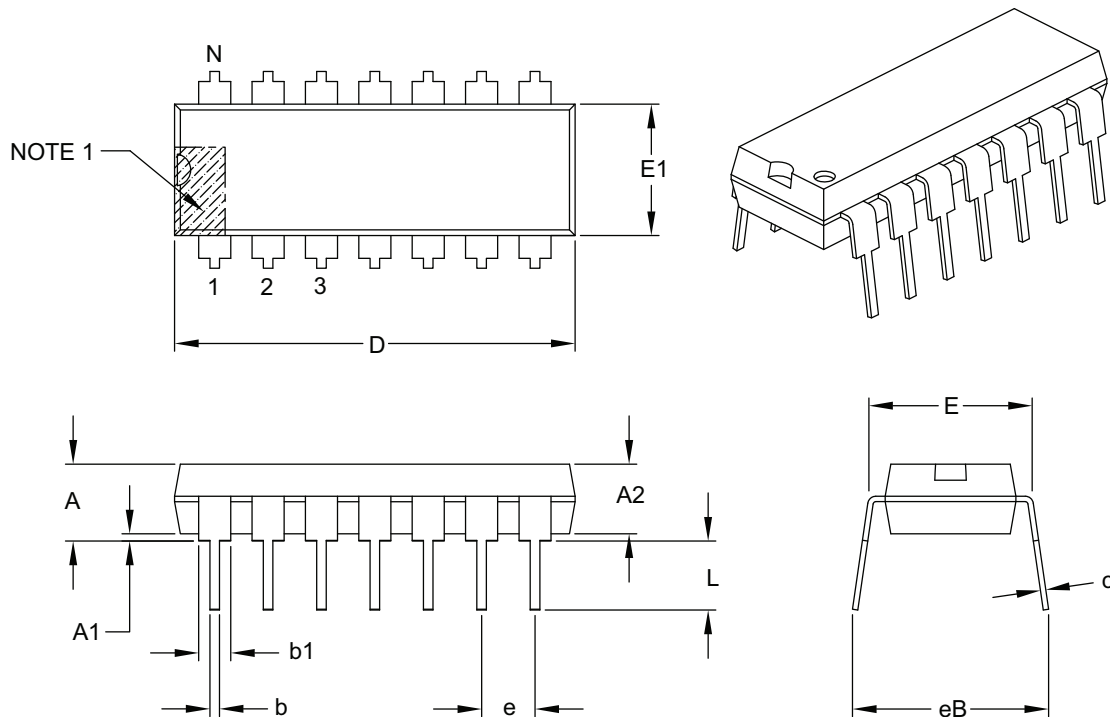


## 24.3 Package Details

The following sections give the technical details of the packages.

### 14-Lead Plastic Dual In-Line (P) – 300 mil Body [PDIP]

**Note:** For the most current package drawings, please see the Microchip Packaging Specification located at <http://www.microchip.com/packaging>



Dimension Limits	Units	INCHES		
		MIN	NOM	MAX
Number of Pins	N	14		
Pitch	e	.100 BSC		
Top to Seating Plane	A	–	–	.210
Molded Package Thickness	A2	.115	.130	.195
Base to Seating Plane	A1	.015	–	–
Shoulder to Shoulder Width	E	.290	.310	.325
Molded Package Width	E1	.240	.250	.280
Overall Length	D	.735	.750	.775
Tip to Seating Plane	L	.115	.130	.150
Lead Thickness	c	.008	.010	.015
Upper Lead Width	b1	.045	.060	.070
Lower Lead Width	b	.014	.018	.022
Overall Row Spacing §	eB	–	–	.430

**Notes:**

1. Pin 1 visual index feature may vary, but must be located with the hatched area.
2. § Significant Characteristic.
3. Dimensions D and E1 do not include mold flash or protrusions. Mold flash or protrusions shall not exceed .010" per side.
4. Dimensioning and tolerancing per ASME Y14.5M.

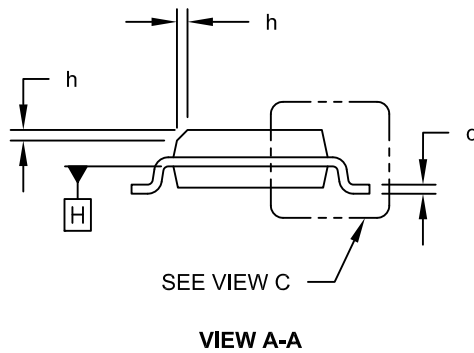
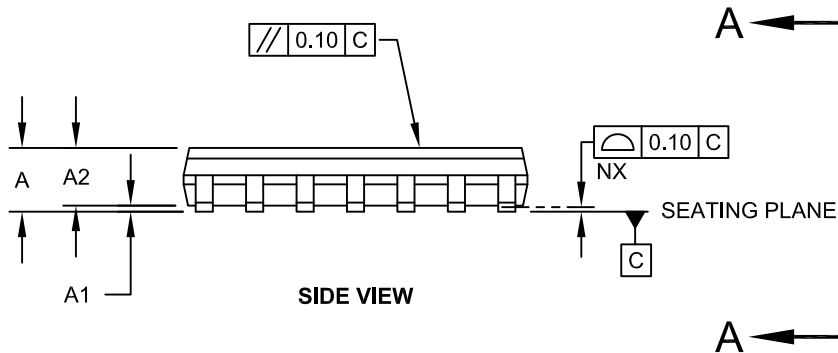
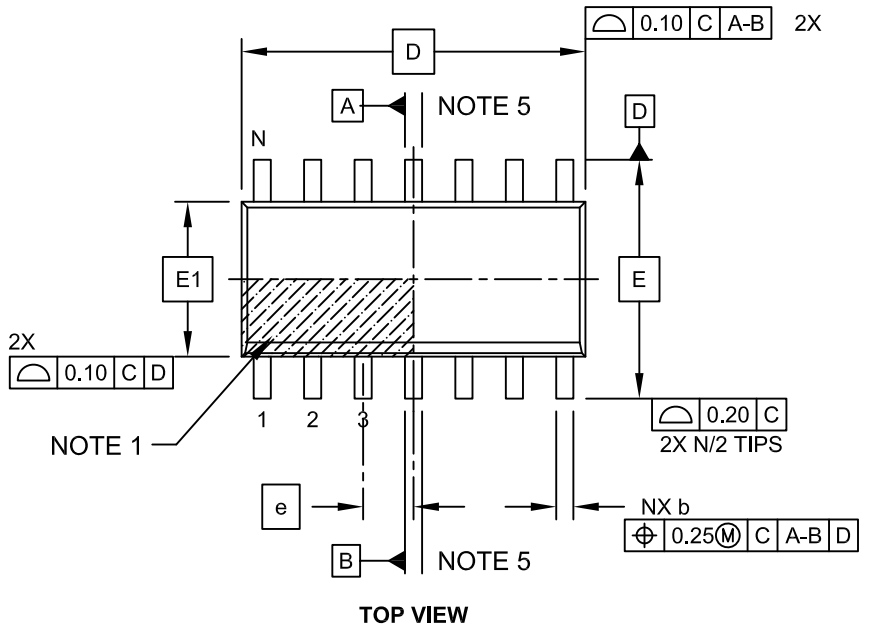
BSC: Basic Dimension. Theoretically exact value shown without tolerances.

Microchip Technology Drawing C04-005B

# PIC16F753/HV753

## 14-Lead Plastic Small Outline (SL) - Narrow, 3.90 mm Body [SOIC]

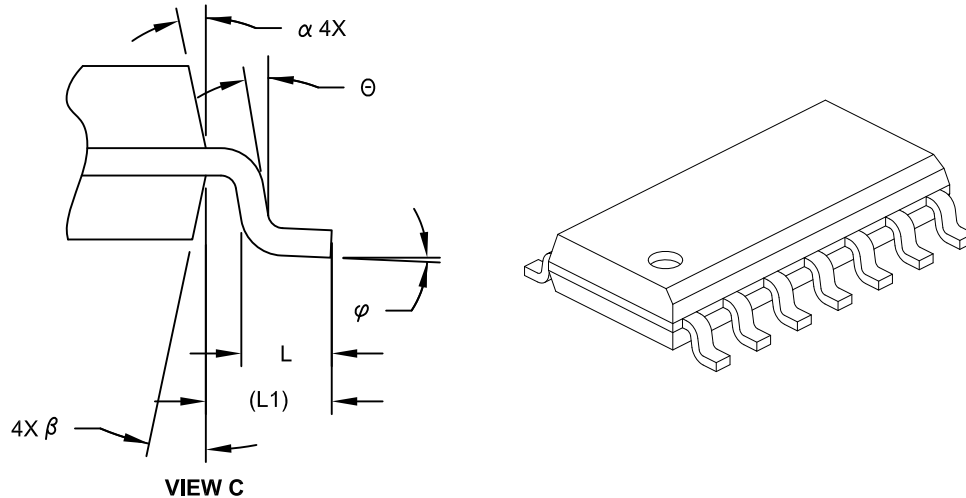
**Note:** For the most current package drawings, please see the Microchip Packaging Specification located at <http://www.microchip.com/packaging>



Microchip Technology Drawing No. C04-065C Sheet 1 of 2

## 14-Lead Plastic Small Outline (SL) - Narrow, 3.90 mm Body [SOIC]

**Note:** For the most current package drawings, please see the Microchip Packaging Specification located at <http://www.microchip.com/packaging>



Dimension Limits	Units	MILLIMETERS		
		MIN	NOM	MAX
Number of Pins	N	14		
Pitch	e	1.27 BSC		
Overall Height	A	-	-	1.75
Molded Package Thickness	A2	1.25	-	-
Standoff §	A1	0.10	-	0.25
Overall Width	E	6.00 BSC		
Molded Package Width	E1	3.90 BSC		
Overall Length	D	8.65 BSC		
Chamfer (Optional)	h	0.25	-	0.50
Foot Length	L	0.40	-	1.27
Footprint	L1	1.04 REF		
Lead Angle	Θ	0°	-	-
Foot Angle	φ	0°	-	8°
Lead Thickness	c	0.10	-	0.25
Lead Width	b	0.31	-	0.51
Mold Draft Angle Top	α	5°	-	15°
Mold Draft Angle Bottom	β	5°	-	15°

**Notes:**

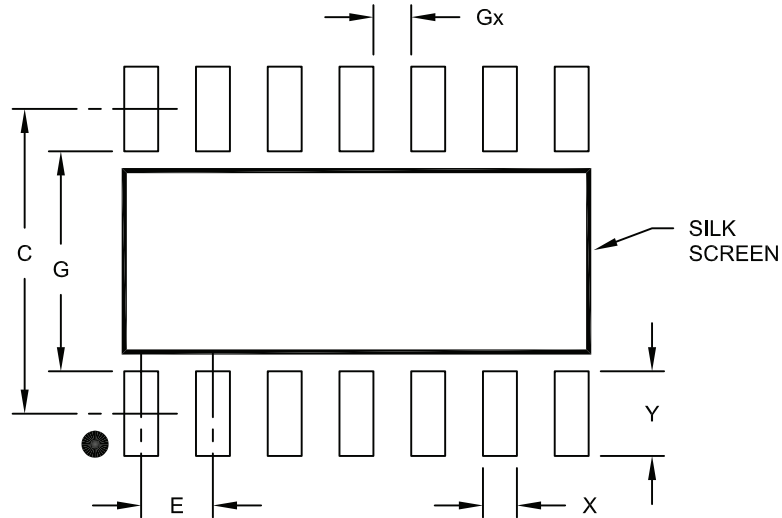
- Pin 1 visual index feature may vary, but must be located within the hatched area.
- § Significant Characteristic
- Dimension D does not include mold flash, protrusions or gate burrs, which shall not exceed 0.15 mm per end. Dimension E1 does not include interlead flash or protrusion, which shall not exceed 0.25 mm per side.
- Dimensioning and tolerancing per ASME Y14.5M  
 BSC: Basic Dimension. Theoretically exact value shown without tolerances.  
 REF: Reference Dimension, usually without tolerance, for information purposes only.
- Datums A & B to be determined at Datum H.

Microchip Technology Drawing No. C04-065C Sheet 2 of 2

# PIC16F753/HV753

14-Lead Plastic Small Outline (SL) - Narrow, 3.90 mm Body [SOIC]

**Note:** For the most current package drawings, please see the Microchip Packaging Specification located at <http://www.microchip.com/packaging>



RECOMMENDED LAND PATTERN

Dimension Limits	Units	MILLIMETERS		
		MIN	NOM	MAX
Contact Pitch	E	1.27 BSC		
Contact Pad Spacing	C		5.40	
Contact Pad Width	X			0.60
Contact Pad Length	Y			1.50
Distance Between Pads	Gx	0.67		
Distance Between Pads	G	3.90		

Notes:

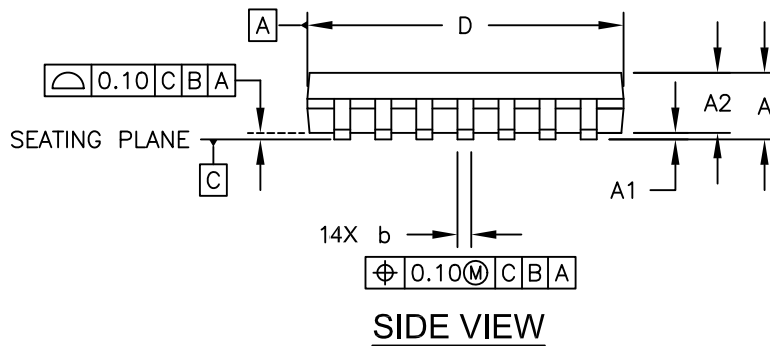
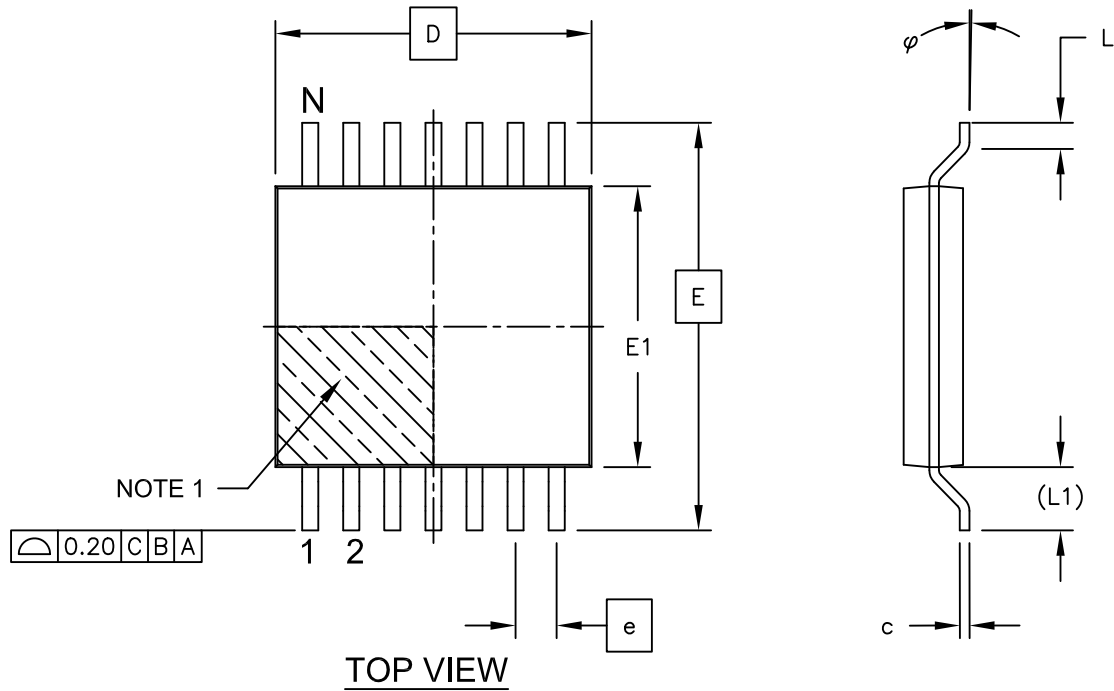
1. Dimensioning and tolerancing per ASME Y14.5M

BSC: Basic Dimension. Theoretically exact value shown without tolerances.

Microchip Technology Drawing No. C04-2065A

## 14-Lead Plastic Thin Shrink Small Outline (ST) - 4.4 mm Body [TSSOP]

**Note:** For the most current package drawings, please see the Microchip Packaging Specification located at <http://www.microchip.com/packaging>

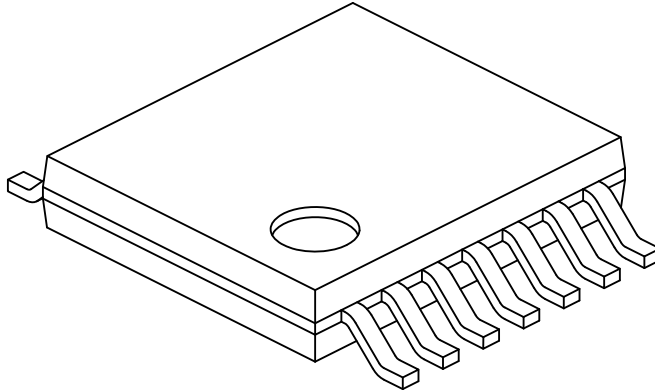


Microchip Technology Drawing C04-087C Sheet 1 of 2

# PIC16F753/HV753

## 14-Lead Plastic Thin Shrink Small Outline (ST) - 4.4 mm Body [TSSOP]

**Note:** For the most current package drawings, please see the Microchip Packaging Specification located at <http://www.microchip.com/packaging>



Dimension Limits	Units	MILLIMETERS		
		MIN	NOM	MAX
Number of Pins	N	14		
Pitch	e	0.65 BSC		
Overall Height	A	-	-	1.20
Molded Package Thickness	A2	0.80	1.00	1.05
Standoff	A1	0.05	-	0.15
Overall Width	E	6.40 BSC		
Molded Package Width	E1	4.30	4.40	4.50
Molded Package Length	D	4.90	5.00	5.10
Foot Length	L	0.45	0.60	0.75
Footprint	(L1)	1.00 REF		
Foot Angle	$\varphi$	0°	-	8°
Lead Thickness	c	0.09	-	0.20
Lead Width	b	0.19	-	0.30

**Notes:**

1. Pin 1 visual index feature may vary, but must be located within the hatched area.
2. Dimensions D and E1 do not include mold flash or protrusions. Mold flash or protrusions shall not exceed 0.15mm per side.
3. Dimensioning and tolerancing per ASME Y14.5M

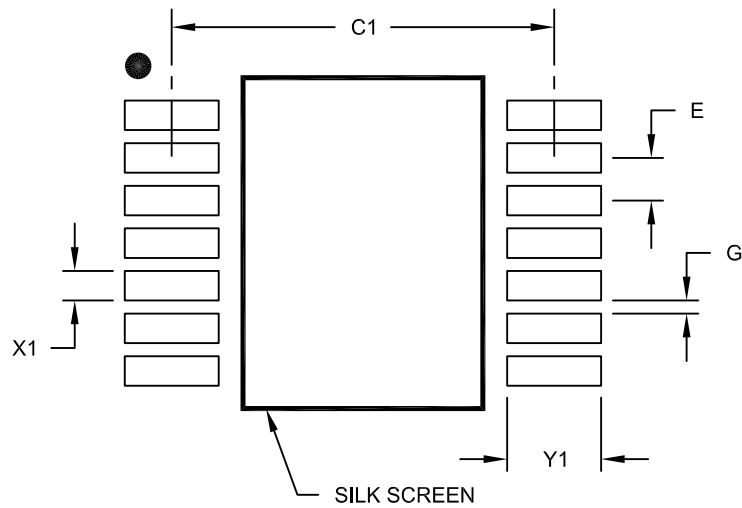
BSC: Basic Dimension. Theoretically exact value shown without tolerances.

REF: Reference Dimension, usually without tolerance, for information purposes only.

Microchip Technology Drawing No. C04-087C Sheet 2 of 2

## 14-Lead Plastic Thin Shrink Small Outline (ST) - 4.4 mm Body [TSSOP]

**Note:** For the most current package drawings, please see the Microchip Packaging Specification located at <http://www.microchip.com/packaging>



RECOMMENDED LAND PATTERN

Dimension Limits	Units	MILLIMETERS		
		MIN	NOM	MAX
Contact Pitch	E	0.65 BSC		
Contact Pad Spacing	C1		5.90	
Contact Pad Width (X14)	X1			0.45
Contact Pad Length (X14)	Y1			1.45
Distance Between Pads	G	0.20		

**Notes:**

1. Dimensioning and tolerancing per ASME Y14.5M

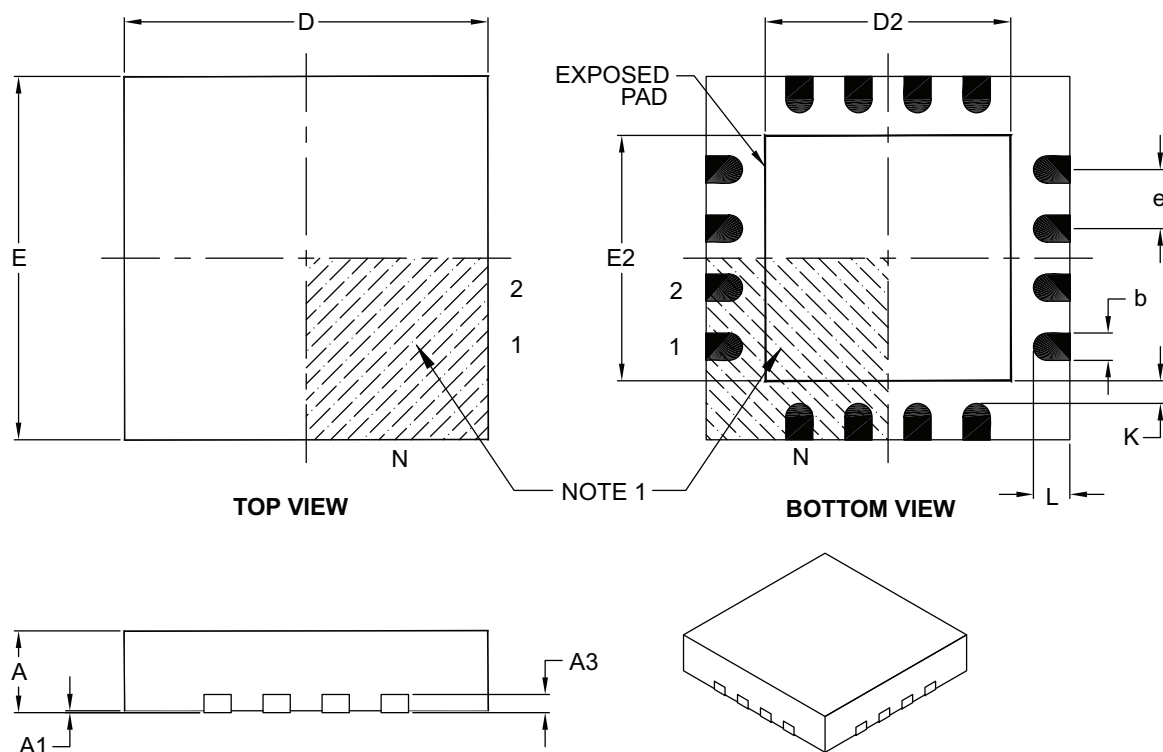
BSC: Basic Dimension. Theoretically exact value shown without tolerances.

Microchip Technology Drawing No. C04-2087A

# PIC16F753/HV753

## 16-Lead Plastic Quad Flat, No Lead Package (ML) – 4x4x0.9 mm Body [QFN]

**Note:** For the most current package drawings, please see the Microchip Packaging Specification located at <http://www.microchip.com/packaging>



Dimension Limits	Units	MILLIMETERS		
		MIN	NOM	MAX
Number of Pins	N	16		
Pitch	e	0.65 BSC		
Overall Height	A	0.80	0.90	1.00
Standoff	A1	0.00	0.02	0.05
Contact Thickness	A3	0.20 REF		
Overall Width	E	4.00 BSC		
Exposed Pad Width	E2	2.50	2.65	2.80
Overall Length	D	4.00 BSC		
Exposed Pad Length	D2	2.50	2.65	2.80
Contact Width	b	0.25	0.30	0.35
Contact Length	L	0.30	0.40	0.50
Contact-to-Exposed Pad	K	0.20	–	–

**Notes:**

- Pin 1 visual index feature may vary, but must be located within the hatched area.
- Package is saw singulated.
- Dimensioning and tolerancing per ASME Y14.5M.

BSC: Basic Dimension. Theoretically exact value shown without tolerances.

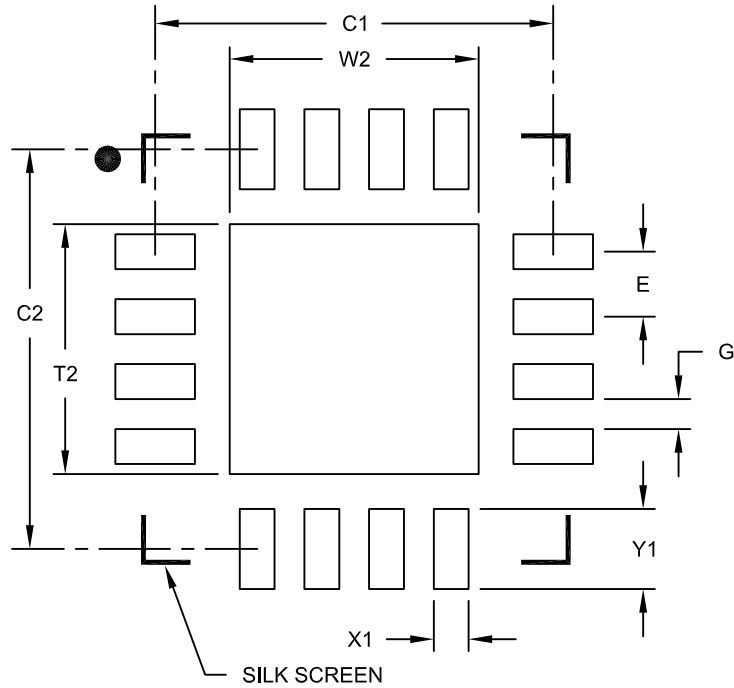
REF: Reference Dimension, usually without tolerance, for information purposes only.

Microchip Technology Drawing C04-127B



## 16-Lead Plastic Quad Flat, No Lead Package (ML) - 4x4x0.9mm Body [QFN]

**Note:** For the most current package drawings, please see the Microchip Packaging Specification located at <http://www.microchip.com/packaging>



RECOMMENDED LAND PATTERN

Dimension Limits	Units	MILLIMETERS		
		MIN	NOM	MAX
Contact Pitch	E	0.65 BSC		
Optional Center Pad Width	W2			2.50
Optional Center Pad Length	T2			2.50
Contact Pad Spacing	C1		4.00	
Contact Pad Spacing	C2		4.00	
Contact Pad Width (X16)	X1			0.35
Contact Pad Length (X16)	Y1			0.80
Distance Between Pads	G	0.30		

**Notes:**

1. Dimensioning and tolerancing per ASME Y14.5M

BSC: Basic Dimension. Theoretically exact value shown without tolerances.

Microchip Technology Drawing No. C04-2127A

# PIC16F753/HV753

---

NOTES:

## APPENDIX A: DATA SHEET REVISION HISTORY

### Revision A (5/2013)

Original release of this document.

# PIC16F753/HV753

---

NOTES:

## INDEX

### A

A/D	
Specifications	209, 210
Absolute Maximum Ratings	187
AC Characteristics	
Industrial and Extended	200
Load Conditions	199
ADC	113
Acquisition Requirements	121
Associated registers	123
Block Diagram	113
Calculating Acquisition Time	121
Channel Selection	114
Configuration	114
Configuring Interrupt	117
Conversion Clock	114
Conversion Procedure	117
Internal Sampling Switch (R <sub>ss</sub> ) Impedance	121
Interrupts	115
Operation	116
Operation During Sleep	116
Port Configuration	114
Reference Voltage (V <sub>REF</sub> )	114
Result Formatting	116
Source Impedance	121
Special Event Trigger	116
Starting an A/D Conversion	116
ADCON0 Register	118
ADCON1 Register	119
ADRESH Register (ADFM = 0)	120
ADRESH Register (ADFM = 1)	120
ADRESL Register (ADFM = 0)	120
ADRESL Register (ADFM = 1)	120
Alternate Pin Function	44
Analog-to-Digital Converter. <i>See</i> ADC	
ANSELA Register	48, 54
APFCON Register	44
Assembler	
MPASM Assembler	184

### B

Block Diagrams	
(CCP) Capture Mode Operation	81
ADC	113
ADC Transfer Function	122
Analog Input Model	122, 138
CCP PWM	85
Clock Source	37
Compare	83
Digital-to-Analog Converter (DAC)	128
Generic I/O Port	43
HLTMR1	77
In-Circuit Serial Programming Connections	179
Interrupt Logic	172
MCLR Circuit	164
On-Chip Reset Circuit	163
OPA Module	143
PIC16F753/HV753	7
Slope Compensation Module	145
Timer1	63, 68, 69, 70
Timer2	75
TMR0/WDT Prescaler	59
Voltage Reference	125

Voltage Reference Output Buffer Example	128
Watchdog Timer	175
Brown-out Reset (BOR)	165
Associated Registers	166
Specifications	204
Timing and Characteristics	203

### C

C Compilers	
MPLAB C18	184
Calibration Bits	163
Capture Module. <i>See</i> Capture/Compare/PWM (CCP)	
Capture/Compare/PWM	81
Capture/Compare/PWM (CCP)	81
Associated Registers w/ Capture	82
Associated Registers w/ Compare	84
Capture Mode	81
CCP1 Pin Configuration	81
Compare Mode	83
CCP1 Pin Configuration	83
Software Interrupt Mode	81, 83
Special Event Trigger	83
Timer1 Mode Resource	81, 83
Prescaler	81
PWM Mode	
Duty Cycle	86
PWM Operation	85
PWM Overview	85
PWM Period	86
PWM Setup	86
Specifications	206
CCP. <i>See</i> Capture/Compare/PWM	
CCP1CON (CCP1) Register	87
Clock Sources	
External Modes	
EC	38
Internal Modes	38
CMOUT Register	140
CMxCON0 Register	139
CMxCON1 Register	140
Code Examples	
A/D Conversion	117
Assigning Prescaler to Timer0	60
Assigning Prescaler to WDT	60
Changing Between Capture Prescalers	81
Indirect Addressing	25
Initializing PORTA	43
Saving Status and W Registers in RAM	174
Writing to Flash Program Memory	34
Code Protection	178
COG	89
Associated registers	111
COGxASD0 Register	106
COGxASD1 Register	107
COGxBLKF Register	109
COGxBLKR Register	109
COGxCON0 Register	100
COGxCON1 Register	101
COGxDBF Register	108
COGxDBR Register	108
COGxFIS Register	104
COGxFSIM Register	105
COGxPHF Register	110
COGxPHR Register	110

# PIC16F753/HV753

COGxRIS Register .....	102
COGxRSIM Register .....	103
Comparator .....	133
Associated Registers .....	141
Operation .....	133
Comparator Module .....	133
Cx Output State Versus Input Conditions .....	135
Comparators .....	
C2OUT as T1 Gate .....	65
Specifications .....	206
Compare Module. See Capture/Compare/PWM (CCP) .....	
Complementary Output Generator (COG) .....	89
CONFIG1 Register .....	162
Configuration Bits .....	161
CPU Features .....	161
Customer Change Notification Service .....	233
Customer Notification Service .....	233
Customer Support .....	233

## D

DACxCON0 (DACx Voltage Reference Control) Register .....	130
DACxREFH Register (DACx $FM=0$ ) .....	131
DACxREFH Register (DACx $FM=1$ ) .....	132
DACxREFL Register (DACx $FM=0$ ) .....	131
DACxREFL Register (DACx $FM=1$ ) .....	132
Data Memory .....	11
DC Characteristics .....	
Extended and Industrial .....	196
Industrial and Extended .....	189
Development Support .....	183
Device Overview .....	7
Digital-to-Analog (DAC) .....	
Specifications .....	207
Digital-to-Analog Converter (DAC) .....	127
Associated Registers .....	132
Effects of a Reset .....	128

## E

Electrical Specifications .....	187
Errata .....	5

## F

Firmware Instructions .....	151
Fixed Voltage Reference (FVR) .....	
Associated Registers .....	126
Specifications .....	207
Flash Program Memory .....	
Associated Registers .....	35
Flash Program Memory Self Read/Self Write Control .....	27
FVRCON (Fixed Voltage Reference Control) Register .....	126

## G

General Purpose Register File .....	11
-------------------------------------	----

## H

Hardware Limit Timer (HLT) .....	77
High Temperature Operation .....	211
HLT .....	
Associated registers .....	80
HLT1CON0 (HLT1 Control 0) Register .....	79
HLT1CON1 (HLT1 Control 1) Register .....	80

## I

ID Locations .....	178
In-Circuit Serial Programming (ICSP) .....	179
Indirect Addressing, INDF and FSR registers .....	25
Instruction Format .....	151
Instruction Set .....	151
ADDLW .....	153
ADDWF .....	153
ANDLW .....	153
ANDWF .....	153
BCF .....	153
BSF .....	153
BTFSC .....	153
BTFSS .....	154
CALL .....	154
CLRf .....	154
CLRWF .....	154
CLRWDt .....	154
COMF .....	154
DECF .....	154
DECFSZ .....	155
GOTO .....	155
INCF .....	155
INCFSZ .....	155
IORLW .....	155
IORWF .....	155
MOVF .....	156
MOVLW .....	156
MOVWF .....	156
NOP .....	156
RETFIE .....	157
RETLW .....	157
RETURN .....	157
RLF .....	158
RRF .....	158
SLEEP .....	158
SUBLW .....	158
SUBWF .....	159
SWAPF .....	159
XORLW .....	159
XORWF .....	159
Summary Table .....	152

INTCON Register .....	19
-----------------------	----

### Internal Oscillator Block

INTOSC .....	
Specifications .....	201, 202
Internal Sampling Switch (R <sub>ss</sub> ) Impedance .....	121
Internet Address .....	233
Interrupts .....	171
ADC .....	117
Associated Registers .....	173
Context Saving .....	174
Interrupt-on-Change .....	47, 53
PORTA Interrupt-on-Change .....	172
RA2/INT .....	171
Timer0 .....	172
TMR1 .....	67
INTOSC Specifications .....	201, 202
IOCAF Register .....	49, 56
IOCAN Register .....	49, 56
IOCAP Register .....	49, 55

## L

LATA Register .....	46, 52
Load Conditions .....	199

## M

MCLR .....	164
Internal .....	164
Memory Organization .....	11
Data .....	11
Program .....	11
Microchip Internet Web Site .....	233
MPLAB ASM30 Assembler, Linker, Librarian .....	184
MPLAB Integrated Development Environment Software ..	183
MPLAB PM3 Device Programmer .....	185
MPLAB REAL ICE In-Circuit Emulator System .....	185
MPLINK Object Linker/MPLIB Object Librarian .....	184

## O

OPCODE Field Descriptions .....	151
Operation During Code Protect .....	32
Operation During Write Protect .....	32
Operational Amplifier (OPA) Module .....	143
AC Specifications .....	207
Associated Registers .....	144
OPTION Register .....	18
OPTION_REG Register .....	61
OSCCON Register .....	40
Oscillator	
Associated registers .....	41, 73
Oscillator Module .....	27, 37
Oscillator Parameters .....	201
Oscillator Specifications .....	200
Oscillator Start-up Timer (OST)	
Specifications .....	204
OSCTUNE Register .....	41

## P

Packaging .....	215
Marking .....	215, 216
PDIP Details .....	216
PCL and PCLATH .....	25
Stack .....	25
PCON Register .....	24, 166
PIC16F753/HV753 .....	8
PIE1 Register .....	20
PIE2 Register .....	21
Pinout Descriptions	
PIC16F753/HV753 .....	8
PIR1 Register .....	22
PIR2 Register .....	23
PMADRH and PMADRL Registers .....	27
PMCON1 and PMCON2 Registers .....	27
PMCON1 Register .....	29
PMDATH Register .....	28
PMDATL Register .....	28
PMDRH Register .....	28
PORTA	
Additional Pin Functions .....	47
ANSEL Register .....	47, 53
Interrupt-on-Change .....	47, 53
Slew Rate Control .....	47, 53
Weak Pull-Ups .....	47, 53
Associated Registers .....	50, 57
RA2 .....	50, 57
RA3 .....	50, 57
RA4 .....	50, 57
Specifications .....	202
PORTA Register .....	46
Power-Down Mode (Sleep) .....	177

Power-on Reset (POR) .....	164
Power-up Timer (PWRT) .....	165
Specifications .....	204
Precision Internal Oscillator Parameters .....	202
Prescaler	
Shared WDT/Timer0 .....	60
Switching Prescaler Assignment .....	60
Program Memory .....	11
Map and Stack .....	11
Programming, Device Instructions .....	151
Protection Against Spurious Write .....	32
PWM (CCP Module)	
PWM Steering .....	87
PWM Steering .....	87

## R

Reader Response .....	234
Reading the Flash Program Memory .....	30
Read-Modify-Write Operations .....	151
Registers	
ADCON0 (ADC Control 0) .....	118
ADCON1 (ADC Control 1) .....	119
ADRESH (ADC Result High) with ADFM = 0 .....	120
ADRESH (ADC Result High) with ADFM = 1 .....	120
ADRESL (ADC Result Low) with ADFM = 0 .....	120
ADRESL (ADC Result Low) with ADFM = 1 .....	120
ANSELA (PORTA Analog Select) .....	48, 54
APFCON (Alternate Pin Function Control) .....	44
CCP1CON (CCP1 Control) .....	87
CMOUT (Comparator Output) .....	140
CMxCON0 (Cx Control) .....	139
CMxCON1 (Cx Control 1) .....	140
COGxASD0 (COG Auto-Shutdown Control 0) .....	106
COGxASD1 (COG Auto-Shutdown Control 1) .....	107
COGxBLKF (COG Falling Event Blanking Count) .....	109
COGxBLKR (COG Rising Event Blanking Count) .....	109
COGxCON0 (COG Control 0) .....	100
COGxCON1 (COG Control 1) .....	101
COGxDBF (COG Falling Event Dead-Band Count) .....	108
COGxDBR (COG Rising Event Dead-Band Count) .....	108
COGxFIS (COG Falling Event Input Selection) .....	104
COGxFSIM (COG Falling Event Source	
Input Mode) .....	105
COGxPHF (COG Falling Edge Phase Delay Count) .....	110
COGxPHR (COG Rising Edge Phase Delay Count) .....	110
COGxRIS (COG Rising Event Input Selection) .....	102
COGxRSIM (COG Rising Event Source	
Input Mode) .....	103
Configuration Word 1 .....	162
DACxCON0 .....	130
DACxREFH (DAC Reference High)	
with DACxFM = 0 .....	131
DACxREFH (DAC Reference High)	
with DACxFM = 1 .....	132
DACxREFL (DAC Reference Low)	
with DACxFM = 0 .....	131
DACxREFL (DAC Reference Low)	
with DACxFM = 1 .....	132
Data Memory Map .....	12
FVRCON .....	126
HLT1CON0 .....	79
HLT1CON1 .....	80
INTCON (Interrupt Control) .....	19
IOCAF (Interrupt-on-Change Flag) .....	49, 56
IOCAN (Interrupt-on-Change Negative Edge) .....	49, 56
IOCAP (Interrupt-on-Change Positive Edge) .....	49, 55

# PIC16F753/HV753

LATA (Data Latch PORTA).....	46, 52
OPTION_REG (OPTION).....	18, 61
OSCCON (Oscillator Control).....	40
OSCTUNE (Oscillator Tuning).....	41
PCON (Power Control).....	24, 166
PIE1 (Peripheral Interrupt Enable 1).....	20
PIE2 (Peripheral Interrupt Enable 2).....	21
PIR1 (Peripheral Interrupt Register 1).....	22
PIR2 (Peripheral Interrupt Register 2).....	23
PMCON1 (Program Memory Control 1).....	29
PMDATH (Program Memory Data).....	28
PMDATL (Program Memory Data).....	28
PMDRH (Program Memory Address).....	28
PORTA.....	46
Reset Values.....	168
Reset Values (special registers).....	170
SLPCCON0.....	148
SLPCCON1.....	148
Special Function Registers.....	11
STATUS.....	17
T1CON (Timer1 Control).....	71
T1GCON (Timer1 Gate Control).....	72
T2CON.....	76
TRISA (Tri-State PORTA).....	46, 52
WPUA (Weak Pull-up PORTA).....	48, 55
Reset.....	163
Revision History.....	227
<b>S</b>	
Shunt Regulator.....	181
Sleep.....	
Power-Down Mode.....	177
Wake-up.....	177
Wake-up using Interrupts.....	177
Slew Rate Control.....	47, 53
Slope Compensation (SC) Module.....	145
Associated Registers.....	149
Configuration Word w/ the Slope Compensation Module.....	149
SLPCCON0 (Slope Compensation Control 0) Register....	148
SLPCCON1 (Slope Compensation Control 1) Register....	148
Software Simulator (MPLAB SIM).....	185
Special Event Trigger.....	116
Special Function Registers.....	11
STATUS Register.....	17
<b>T</b>	
T1CON Register.....	71
T1GCON Register.....	72
T2CON Register.....	76
Thermal Considerations.....	198
Time-out Sequence.....	166
Timer0.....	59
Associated Registers.....	61
External Clock.....	60
Interrupt.....	61
Operation.....	59, 64
Specifications.....	205
T0CKI.....	60
Timer1.....	
Associated registers.....	73
Asynchronous Counter Mode.....	65
Reading and Writing.....	65
Interrupt.....	67
Modes of Operation.....	64
Operation During Sleep.....	67
Prescaler.....	65
Specifications.....	205
Timer1 Gate Selecting Source.....	65
TMR1H Register.....	63
TMR1L Register.....	63
Timer2.....	
Associated registers.....	76, 80
Timers.....	
HLT.....	
HLT1CON0.....	79
HLT1CON1.....	80
Timer1.....	
T1CON.....	71
T1GCON.....	72
Timer2.....	
T2CON.....	76
Timing Diagrams.....	
A/D Conversion.....	210
A/D Conversion (Sleep Mode).....	211
Brown-out Reset (BOR).....	203
Brown-out Reset Situations.....	165
Capture/Compare/PWM (CCP).....	206
CLKOUT and I/O.....	202
Clock Timing.....	200
Comparator Output.....	133
INT Pin Interrupt.....	173
Time-out Sequence.....	
Case 1.....	166
Case 2.....	167
Case 3.....	167
Timer0 and Timer1 External Clock.....	205
Timer1 Incrementing Edge.....	67
Wake-up from Interrupt.....	178
Timing Parameter Symbology.....	199
TRISA Register.....	46, 52
<b>V</b>	
VREF. SEE ADC Reference Voltage.....	
<b>W</b>	
Wake-up Using Interrupts.....	177
Watchdog Timer (WDT).....	174
Associated registers.....	176
Specifications.....	204
WPUA Register.....	48, 55
Writing the Flash Program Memory.....	32
WWW Address.....	233
WWW, On-Line Support.....	2, 5



## THE MICROCHIP WEB SITE

Microchip provides online support via our WWW site at [www.microchip.com](http://www.microchip.com). This web site is used as a means to make files and information easily available to customers. Accessible by using your favorite Internet browser, the web site contains the following information:

- **Product Support** – Data sheets and errata, application notes and sample programs, design resources, user's guides and hardware support documents, latest software releases and archived software
- **General Technical Support** – Frequently Asked Questions (FAQ), technical support requests, online discussion groups, Microchip consultant program member listing
- **Business of Microchip** – Product selector and ordering guides, latest Microchip press releases, listing of seminars and events, listings of Microchip sales offices, distributors and factory representatives

## CUSTOMER CHANGE NOTIFICATION SERVICE

Microchip's customer notification service helps keep customers current on Microchip products. Subscribers will receive e-mail notification whenever there are changes, updates, revisions or errata related to a specified product family or development tool of interest.

To register, access the Microchip web site at [www.microchip.com](http://www.microchip.com). Under "Support", click on "Customer Change Notification" and follow the registration instructions.

## CUSTOMER SUPPORT

Users of Microchip products can receive assistance through several channels:

- Distributor or Representative
- Local Sales Office
- Field Application Engineer (FAE)
- Technical Support
- Development Systems Information Line

Customers should contact their distributor, representative or field application engineer (FAE) for support. Local sales offices are also available to help customers. A listing of sales offices and locations is included in the back of this document.

**Technical support is available through the web site at: <http://microchip.com/support>**

# PIC16F753/HV753

---

---

## READER RESPONSE

It is our intention to provide you with the best documentation possible to ensure successful use of your Microchip product. If you wish to provide your comments on organization, clarity, subject matter, and ways in which our documentation can better serve you, please FAX your comments to the Technical Publications Manager at (480) 792-4150.

Please list the following information, and use this outline to provide us with your comments about this document.

TO: Technical Publications Manager Total Pages Sent \_\_\_\_\_

RE: Reader Response

From: Name \_\_\_\_\_

Company \_\_\_\_\_

Address \_\_\_\_\_

City / State / ZIP / Country \_\_\_\_\_

Telephone: (\_\_\_\_\_) \_\_\_\_\_ - \_\_\_\_\_ FAX: (\_\_\_\_\_) \_\_\_\_\_ - \_\_\_\_\_

Application (optional):

Would you like a reply?  Y  N

Device: PIC16F753/HV753

Literature Number: DS40001709A

Questions:

1. What are the best features of this document?

\_\_\_\_\_  
\_\_\_\_\_

2. How does this document meet your hardware and software development needs?

\_\_\_\_\_  
\_\_\_\_\_

3. Do you find the organization of this document easy to follow? If not, why?

\_\_\_\_\_  
\_\_\_\_\_

4. What additions to the document do you think would enhance the structure and subject?

\_\_\_\_\_  
\_\_\_\_\_

5. What deletions from the document could be made without affecting the overall usefulness?

\_\_\_\_\_  
\_\_\_\_\_

6. Is there any incorrect or misleading information (what and where)?

\_\_\_\_\_  
\_\_\_\_\_

7. How would you improve this document?

\_\_\_\_\_  
\_\_\_\_\_

## PRODUCT IDENTIFICATION SYSTEM

To order or obtain information, e.g., on pricing or delivery, refer to the factory or the listed sales office.

<u>PART NO.</u>	<u>[X]<sup>(1)</sup></u>	-	<u>X</u>	<u>/XX</u>	<u>XXX</u>
Device	Tape and Reel Option		Temperature Range	Package	Pattern
<b>Device:</b>	PIC16F753 PIC16HV753				
<b>Tape and Reel Option:</b>	Blank = Standard packaging (tube or tray) T = Tape and Reel <sup>(1)</sup>				
<b>Temperature Range:</b>	I = -40°C to +85°C (Industrial) E = -40°C to +125°C (Extended)				
<b>Package:</b>	P = 14-lead Plastic Dual In-line (PDIP) SL = 14-lead Plastic Small Outline (3.90 mm) (SOIC) ST = 14-lead Plastic Thin Shrink Small Outline (4.4 mm) (TSSOP) ML = 16-lead Plastic Quad Flat, No Lead Package (4x4x0.9 mm) (QFN)				
<b>Pattern:</b>	QTP, SQTP, Code or Special Requirements (blank otherwise)				
<b>Examples:</b>					
a) PIC16F753-I/ML301 Tape and Reel, Industrial temperature, QFN 4x43 package, QTP pattern #301					
b) PIC16F753-E/P Extended temperature PDIP package					
c) PIC16F753-E/SL Extended temperature, SOIC package					
d) PIC16HV753-E/ST Extended temperature, TSSOP 4.4 mm package					
<b>Note 1:</b> Tape and Reel identifier only appears in the catalog part number description. This identifier is used for ordering purposes and is not printed on the device package. Check with your Microchip Sales Office for package availability with the Tape and Reel option.					

# PIC16F753/HV753

---

NOTES:

---

**Note the following details of the code protection feature on Microchip devices:**

- Microchip products meet the specification contained in their particular Microchip Data Sheet.
- Microchip believes that its family of products is one of the most secure families of its kind on the market today, when used in the intended manner and under normal conditions.
- There are dishonest and possibly illegal methods used to breach the code protection feature. All of these methods, to our knowledge, require using the Microchip products in a manner outside the operating specifications contained in Microchip's Data Sheets. Most likely, the person doing so is engaged in theft of intellectual property.
- Microchip is willing to work with the customer who is concerned about the integrity of their code.
- Neither Microchip nor any other semiconductor manufacturer can guarantee the security of their code. Code protection does not mean that we are guaranteeing the product as “unbreakable.”

Code protection is constantly evolving. We at Microchip are committed to continuously improving the code protection features of our products. Attempts to break Microchip's code protection feature may be a violation of the Digital Millennium Copyright Act. If such acts allow unauthorized access to your software or other copyrighted work, you may have a right to sue for relief under that Act.

---

Information contained in this publication regarding device applications and the like is provided only for your convenience and may be superseded by updates. It is your responsibility to ensure that your application meets with your specifications. MICROCHIP MAKES NO REPRESENTATIONS OR WARRANTIES OF ANY KIND WHETHER EXPRESS OR IMPLIED, WRITTEN OR ORAL, STATUTORY OR OTHERWISE, RELATED TO THE INFORMATION, INCLUDING BUT NOT LIMITED TO ITS CONDITION, QUALITY, PERFORMANCE, MERCHANTABILITY OR FITNESS FOR PURPOSE. Microchip disclaims all liability arising from this information and its use. Use of Microchip devices in life support and/or safety applications is entirely at the buyer's risk, and the buyer agrees to defend, indemnify and hold harmless Microchip from any and all damages, claims, suits, or expenses resulting from such use. No licenses are conveyed, implicitly or otherwise, under any Microchip intellectual property rights.

#### **Trademarks**

The Microchip name and logo, the Microchip logo, dsPIC, FlashFlex, KEELOQ, KEELOQ logo, MPLAB, PIC, PICmicro, PICSTART, PIC<sup>32</sup> logo, rPIC, SST, SST Logo, SuperFlash and UNI/O are registered trademarks of Microchip Technology Incorporated in the U.S.A. and other countries.

FilterLab, Hampshire, HI-TECH C, Linear Active Thermistor, MTP, SEEVAL and The Embedded Control Solutions Company are registered trademarks of Microchip Technology Incorporated in the U.S.A.

Silicon Storage Technology is a registered trademark of Microchip Technology Inc. in other countries.


Analog-for-the-Digital Age, Application Maestro, BodyCom, chipKIT, chipKIT logo, CodeGuard, dsPICDEM, dsPICDEM.net, dsPICworks, dsSPEAK, ECAN, ECONOMONITOR, FanSense, HI-TIDE, In-Circuit Serial Programming, ICSP, Mindi, MiWi, MPASM, MPF, MPLAB Certified logo, MPLIB, MPLINK, mTouch, Omniclient Code Generation, PICC, PICC-18, PICDEM, PICDEM.net, PICkit, PICtail, REAL ICE, rLAB, Select Mode, SQI, Serial Quad I/O, Total Endurance, TSHARC, UniWinDriver, WiperLock, ZENA and Z-Scale are trademarks of Microchip Technology Incorporated in the U.S.A. and other countries.

SQTP is a service mark of Microchip Technology Incorporated in the U.S.A.

GestIC and ULPP are registered trademarks of Microchip Technology Germany II GmbH & Co. KG, a subsidiary of Microchip Technology Inc., in other countries.

All other trademarks mentioned herein are property of their respective companies.

© 2013, Microchip Technology Incorporated, Printed in the U.S.A., All Rights Reserved.

 Printed on recycled paper.

ISBN: 9781620771976

**QUALITY MANAGEMENT SYSTEM**  
**CERTIFIED BY DNV**  
**== ISO/TS 16949 ==**

*Microchip received ISO/TS-16949:2009 certification for its worldwide headquarters, design and wafer fabrication facilities in Chandler and Tempe, Arizona; Gresham, Oregon and design centers in California and India. The Company's quality system processes and procedures are for its PIC® MCUs and dsPIC® DSCs, KEELOQ® code hopping devices, Serial EEPROMs, microperipherals, nonvolatile memory and analog products. In addition, Microchip's quality system for the design and manufacture of development systems is ISO 9001:2000 certified.*



# MICROCHIP

## Worldwide Sales and Service

### AMERICAS

**Corporate Office**  
2355 West Chandler Blvd.  
Chandler, AZ 85224-6199  
Tel: 480-792-7200  
Fax: 480-792-7277  
Technical Support:  
<http://www.microchip.com/support>  
Web Address:  
[www.microchip.com](http://www.microchip.com)

**Atlanta**  
Duluth, GA  
Tel: 678-957-9614  
Fax: 678-957-1455

**Boston**  
Westborough, MA  
Tel: 774-760-0087  
Fax: 774-760-0088

**Chicago**  
Itasca, IL  
Tel: 630-285-0071  
Fax: 630-285-0075

**Cleveland**  
Independence, OH  
Tel: 216-447-0464  
Fax: 216-447-0643

**Dallas**  
Addison, TX  
Tel: 972-818-7423  
Fax: 972-818-2924

**Detroit**  
Farmington Hills, MI  
Tel: 248-538-2250  
Fax: 248-538-2260

**Indianapolis**  
Noblesville, IN  
Tel: 317-773-8323  
Fax: 317-773-5453

**Los Angeles**  
Mission Viejo, CA  
Tel: 949-462-9523  
Fax: 949-462-9608

**Santa Clara**  
Santa Clara, CA  
Tel: 408-961-6444  
Fax: 408-961-6445

**Toronto**  
Mississauga, Ontario,  
Canada  
Tel: 905-673-0699  
Fax: 905-673-6509

### ASIA/PACIFIC

**Asia Pacific Office**  
Suites 3707-14, 37th Floor  
Tower 6, The Gateway  
Harbour City, Kowloon  
Hong Kong  
Tel: 852-2401-1200  
Fax: 852-2401-3431

**Australia - Sydney**  
Tel: 61-2-9868-6733  
Fax: 61-2-9868-6755

**China - Beijing**  
Tel: 86-10-8569-7000  
Fax: 86-10-8528-2104

**China - Chengdu**  
Tel: 86-28-8665-5511  
Fax: 86-28-8665-7889

**China - Chongqing**  
Tel: 86-23-8980-9588  
Fax: 86-23-8980-9500

**China - Hangzhou**  
Tel: 86-571-2819-3187  
Fax: 86-571-2819-3189

**China - Hong Kong SAR**  
Tel: 852-2943-5100  
Fax: 852-2401-3431

**China - Nanjing**  
Tel: 86-25-8473-2460  
Fax: 86-25-8473-2470

**China - Qingdao**  
Tel: 86-532-8502-7355  
Fax: 86-532-8502-7205

**China - Shanghai**  
Tel: 86-21-5407-5533  
Fax: 86-21-5407-5066

**China - Shenyang**  
Tel: 86-24-2334-2829  
Fax: 86-24-2334-2393

**China - Shenzhen**  
Tel: 86-755-8864-2200  
Fax: 86-755-8203-1760

**China - Wuhan**  
Tel: 86-27-5980-5300  
Fax: 86-27-5980-5118

**China - Xian**  
Tel: 86-29-8833-7252  
Fax: 86-29-8833-7256

**China - Xiamen**  
Tel: 86-592-2388138  
Fax: 86-592-2388130

**China - Zhuhai**  
Tel: 86-756-3210040  
Fax: 86-756-3210049

### ASIA/PACIFIC

**India - Bangalore**  
Tel: 91-80-3090-4444  
Fax: 91-80-3090-4123

**India - New Delhi**  
Tel: 91-11-4160-8631  
Fax: 91-11-4160-8632

**India - Pune**  
Tel: 91-20-2566-1512  
Fax: 91-20-2566-1513

**Japan - Osaka**  
Tel: 81-6-6152-7160  
Fax: 81-6-6152-9310

**Japan - Tokyo**  
Tel: 81-3-6880-3770  
Fax: 81-3-6880-3771

**Korea - Daegu**  
Tel: 82-53-744-4301  
Fax: 82-53-744-4302

**Korea - Seoul**  
Tel: 82-2-554-7200  
Fax: 82-2-558-5932 or  
82-2-558-5934

**Malaysia - Kuala Lumpur**  
Tel: 60-3-6201-9857  
Fax: 60-3-6201-9859

**Malaysia - Penang**  
Tel: 60-4-227-8870  
Fax: 60-4-227-4068

**Philippines - Manila**  
Tel: 63-2-634-9065  
Fax: 63-2-634-9069

**Singapore**  
Tel: 65-6334-8870  
Fax: 65-6334-8850

**Taiwan - Hsin Chu**  
Tel: 886-3-5778-366  
Fax: 886-3-5770-955

**Taiwan - Kaohsiung**  
Tel: 886-7-213-7828  
Fax: 886-7-330-9305

**Taiwan - Taipei**  
Tel: 886-2-2508-8600  
Fax: 886-2-2508-0102

**Thailand - Bangkok**  
Tel: 66-2-694-1351  
Fax: 66-2-694-1350

### EUROPE

**Austria - Wels**  
Tel: 43-7242-2244-39  
Fax: 43-7242-2244-393

**Denmark - Copenhagen**  
Tel: 45-4450-2828  
Fax: 45-4485-2829

**France - Paris**  
Tel: 33-1-69-53-63-20  
Fax: 33-1-69-30-90-79

**Germany - Munich**  
Tel: 49-89-627-144-0  
Fax: 49-89-627-144-44

**Italy - Milan**  
Tel: 39-0331-742611  
Fax: 39-0331-466781

**Netherlands - Drunen**  
Tel: 31-416-690399  
Fax: 31-416-690340

**Spain - Madrid**  
Tel: 34-91-708-08-90  
Fax: 34-91-708-08-91

**UK - Wokingham**  
Tel: 44-118-921-5869  
Fax: 44-118-921-5820

11/29/12