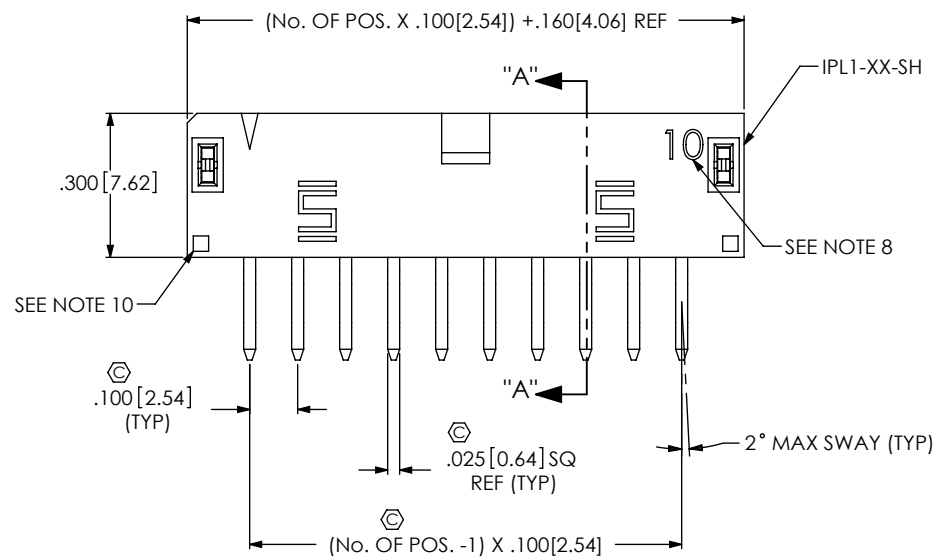
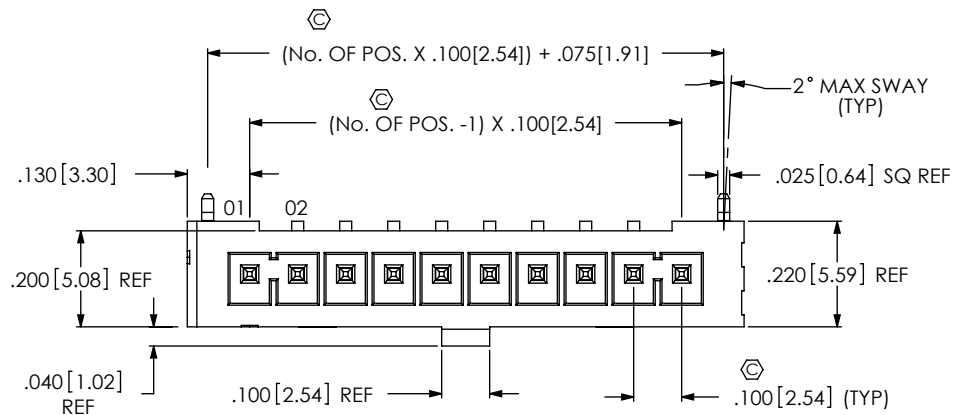

FIG. 1
(IPL1-110-02-XXX-SH-K SHOWN)



IPL1-1XX-XX-XXX-SH-K-XX **B**

No OF POSITIONS
-02 THRU -25

LEAD STYLE
-02: SINGLE HORIZONTAL .062 BOARD (USE T-1S64-09-XXX)
-03: SINGLE HORIZONTAL .093 BOARD (USE T-1S64-09-XXX)

PLATING SPECIFICATION
-F: FLASH SELECTIVE (USE T-1S64-09-F)
-L: LIGHT SELECTIVE (USE T-1S64-09-L)
-S: SELECTIVE (USE T-1S64-09-S)
-STL: SELECTIVE TIN/LEAD (USE T-1S64-09-STL)

OPTION
-TR: TAPE & REEL (SEE NOTE 9)

POLARIZATION
-K: KEYED POLARIZATION

ROW SPECIFICATION
-SH: SINGLE HORIZONTAL

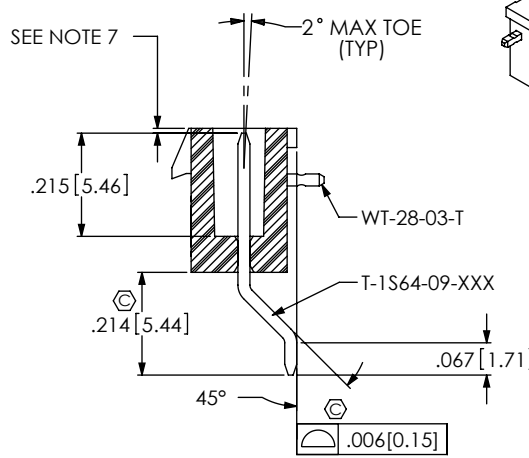
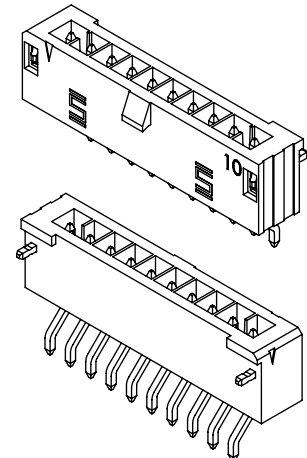

SECTION "A"- "A"
SCALE 2.5 : 1

- NOTES:
1. C REPRESENTS A CRITICAL DIMENSION.
 2. MINIMUM TERMINAL / WELD TAB RETENTION: 1.0LB. [4.4N]
 3. PARTS TO BE MOLDED TO POSITION.
 4. POST MUST BE WITHIN .005[0.13] OF EACH OTHER.
 5. ALL PIN TO PIN DIMENSIONS TO BE MEASURED FROM TIP TO TIP.
 6. DIMENSION TO BE MEASURED AT BEND.
 7. TIP TO BE FLUSH TO .010[0.254] BELOW TOP OF SHROUD.
 8. THIS NUMBER REPRESENTS THE NUMBER OF POSITIONS PER ROW ONLY AND IS NOT INTENDED TO BE USED IN POSITION NUMBERING.
 9. PARTS TO BE PACKAGED IN TUBES IF TAPE & REEL IS NOT SPECIFIED. **B**
 10. INDENTION FROM WELD TAB CARRIER IS ALLOWABLE.

<p>UNLESS OTHERWISE SPECIFIED, DIMENSIONS ARE IN INCHES. TOLERANCES ARE:</p> <p>DECIMALS ANGLES</p> <p>.XX: $\pm .01$ [.3] 2°</p> <p>.XXX: $\pm .005$ [.13]</p> <p>.XXXX: $\pm .0020$ [.051]</p>	<p>PROPRIETARY NOTE</p> <p>THIS DOCUMENT CONTAINS INFORMATION CONFIDENTIAL AND PROPRIETARY TO SAMTEC, INC. AND SHALL NOT BE REPRODUCED OR TRANSFERRED TO OTHER DOCUMENTS OR DISCLOSED TO OTHERS OR USED FOR ANY PURPOSE OTHER THAN THAT WHICH IT WAS OBTAINED WITHOUT THE EXPRESSED WRITTEN CONSENT OF SAMTEC, INC.</p>	<p>samtec</p> <p>520 PARK EAST BLVD, NEW ALBANY, IN 47150 PHONE: 812-944-6733 FAX: 812-948-5047 e-Mail: info@SAMTEC.com code: 55322</p>

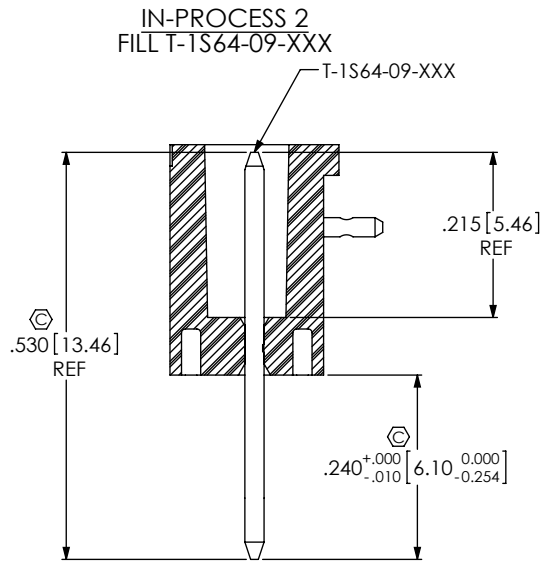
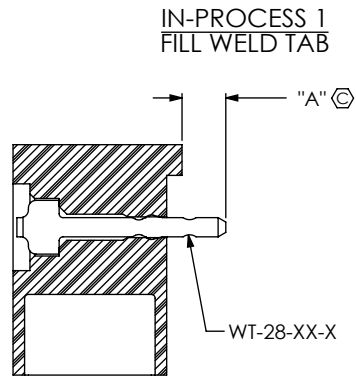

B PACKAGING VIEW
 (PARTS TO HAVE POSITION #T LOADED
 IN SAME DIRECTION AS ARROW ON TUBE)

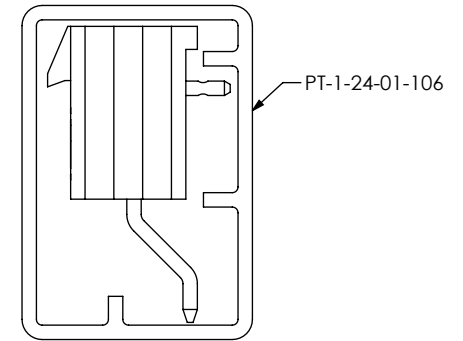

PACKAGING TABLE		
LEAD STYLE	PACKAGING TUBE	PLUG
-02	PT-1-24-01-106	TP-07
-03	PT-1-24-01-106	TP-07

TABLE 1		
LEAD STYLE	"A"	WELD TAB
-02	.055	WT-28-03-X
-03	.086	WT-28-04-X

FIG. 2
 (IPL1-125-02-XXX-SH-K SHOWN)
 (DIFFERENT AS SHOWN, OTHERWISE SAME AS FIG. 1)

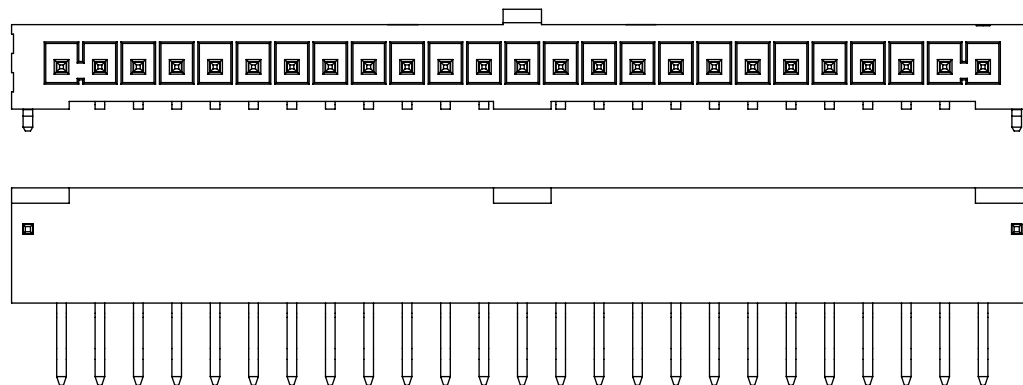

PROPRIETARY NOTE
 THIS DOCUMENT CONTAINS INFORMATION
 CONFIDENTIAL AND PROPRIETARY TO
 SAMTEC, INC. AND SHALL NOT BE REPRODUCED
 OR TRANSFERRED TO OTHER DOCUMENTS OR
 DISCLOSED TO OTHERS OR USED FOR ANY
 PURPOSE OTHER THAN THAT WHICH IT WAS
 OBTAINED WITHOUT THE EXPRESSED WRITTEN
 CONSENT OF SAMTEC, INC.

DO NOT SCALE DRAWING

SHEET SCALE: 2:1



520 PARK EAST BLVD, NEW ALBANY, IN 47150
 PHONE: 812-944-6733 FAX: 812-948-5047
 e-Mail: info@SAMTEC.com code: 55322

DESCRIPTION:
 .100[2.54] SINGLE ROW TERMINAL ASSEMBLY

DWG. NO.
 IPL1-1XX-XX-XXX-SH-K-XX

BY: D. SCHMELZ 10/31/2008 SHEET 2 OF 2