

HA-2600, HA-2602, HA-2605

12MHz, High Input Impedance Operational Amplifiers

November 1996

Features

- Bandwidth..... 12MHz
- High Input Impedance..... 500M Ω
- Low Input Bias Current..... 1nA
- Low Input Offset Current..... 1nA
- Low Input Offset Voltage..... 0.5mV
- High Gain..... 150kV/V
- Slew Rate..... 7V/ μ s
- Output Short Circuit Protection
- Unity Gain Stable

Applications

- Video Amplifier
- Pulse Amplifier
- Audio Amplifiers and Filters
- High-Q Active Filters
- High-Speed Comparators
- Low Distortion Oscillators

Ordering Information

PART NUMBER (BRAND)	TEMP. RANGE (°C)	PACKAGE	PKG. NO.
HA2-2600-2	-55 to 125	8 Pin Metal Can	T8.C
HA2-2602-2	-55 to 125	8 Pin Metal Can	T8.C
HA2-2605-5	0 to 75	8 Pin Metal Can	T8.C
HA3-2605-5	0 to 75	8 Ld PDIP	E8.3
HA7-2600-2	-55 to 125	8 Ld CERDIP	F8.3A
HA7-2602-2	-55 to 125	8 Ld CERDIP	F8.3A
HA7-2605-5	0 to 75	8 Ld CERDIP	F8.3A
HA9P2605-5 (H26055)	0 to 75	8 Ld SOIC	M8.15

Description

HA-2600/2602/2605 are internally compensated bipolar operational amplifiers that feature very high input impedance (500M Ω , HA-2600) coupled with wideband AC performance. The high resistance of the input stage is complemented by low offset voltage (0.5mV, HA-2600) and low bias and offset current (1nA, HA-2600) to facilitate accurate signal processing. Input offset can be reduced further by means of an external nulling potentiometer. 12MHz unity gain-bandwidth, 7V/ μ s slew rate and 150kV/V open-loop gain enables HA-2600/2602/2605 to perform high-gain amplification of fast, wideband signals. These dynamic characteristics, coupled with fast settling times, make these amplifiers ideally suited to pulse amplification designs as well as high frequency (e.g. video) applications. The frequency response of the amplifier can be tailored to exact design requirements by means of an external bandwidth control capacitor.

In addition to its application in pulse and video amplifier designs, HA-2600/2602/2605 are particularly suited to other high performance designs such as high-gain low distortion audio amplifiers, high-Q and wideband active filters and high-speed comparators. For more information, please refer to Application Note AN515.

The HA-2600 and HA-2602 are offered as /883 Military Grade; product and data sheets are available upon request.

Pinouts

HA-2600/02 (CERDIP)
HA-2605 (PDIP, CERDIP, SOIC)
TOP VIEW

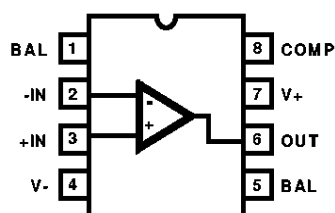

HA-2600/02/05
(METAL CAN)
TOP VIEW

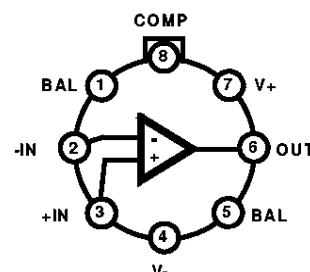

HA-2600, HA-2602, HA-2605

Absolute Maximum Ratings

Supply Voltage Between V+ and V- Terminals 45V
 Differential Input Voltage 12V
 Peak Output Current Full Short Circuit Protection

Operating Conditions

Temperature Range
 HA-2600/HA-2602-2 -55°C to 125°C
 HA-2605-5 0°C to 75°C
 HA-2605-9 -40°C to 85°C

Thermal Information

Thermal Resistance (Typical, Note 1)	θ_{JA} (°C/W)	θ_{JC} (°C/W)
Metal Can Package	165	80
PDIP Package	96	N/A
CERDIP Package	135	50
SOIC Package	157	N/A
Maximum Junction Temperature (Hermetic Package)	175°C	
Maximum Junction Temperature (Plastic Package)	150°C	
Maximum Storage Temperature Range	-65°C to 150°C	
Maximum Lead Temperature (Soldering 10s)	300°C (SOIC - Lead Tips Only)	

CAUTION: Stresses above those listed in "Absolute Maximum Ratings" may cause permanent damage to the device. This is a stress only rating and operation of the device at these or any other conditions above those indicated in the operational sections of this specification is not implied.

NOTE:

- θ_{JA} is measured with the component mounted on an evaluation PC board in free air.

Electrical Specifications $V_{SUPPLY} = \pm 15V$, Unless Otherwise Specified

PARAMETER	TEMP. (°C)	HA-2600-2			HA-2602-2			HA-2605-9 HA-2605-5			UNITS
		MIN	TYP	MAX	MIN	TYP	MAX	MIN	TYP	MAX	
INPUT CHARACTERISTICS											
Offset Voltage	25	-	0.5	4	-	3	5	-	3	5	mV
	Full	-	2	6	-	-	7	-	-	7	mV
Average Offset Voltage Drift	Full	-	5	-	-	5	-	-	5	-	$\mu V/^\circ C$
Bias Current (Note 2)	25	-	1	10	-	15	25	-	5	25	nA
	Full	-	10	30	-	-	60	-	-	40	nA
Offset Current (Note 2)	25	-	1	10	-	5	25	-	5	25	nA
	Full	-	5	30	-	-	60	-	-	40	nA
Differential Input Resistance (Note 12)	25	100	500	-	40	300	-	40	300	-	M Ω
Input Noise Voltage Density (f = 1kHz)	25	-	11	-	-	11	-	-	11	-	nV/ \sqrt{Hz}
Input Noise Current Density (f = 1kHz)	25	-	0.16	-	-	0.16	-	-	0.16	-	pA/ \sqrt{Hz}
Common Mode Range	Full	± 11	± 12	-	± 11	± 12	-	± 11	± 12	-	V
TRANSFER CHARACTERISTICS											
Large Signal Voltage Gain (Notes 3, 6)	25	100	150	-	80	150	-	80	150	-	kV/V
	Full	70	-	-	60	-	-	70	-	-	kV/V
Common Mode Rejection Ratio (Note 4)	Full	80	100	-	74	100	-	74	100	-	dB
Minimum Stable Gain	25	1	-	-	1	-	-	1	-	-	V/V
Gain Bandwidth Product (Note 5)	25	-	12	-	-	12	-	-	12	-	MHz
OUTPUT CHARACTERISTICS											
Output Voltage Swing (Note 3)	Full	± 10	± 12	-	± 10	± 12	-	± 10	± 12	-	V
Output Current (Note 6)	25	± 15	± 22	-	± 10	± 18	-	± 10	± 18	-	mA
Full Power Bandwidth (Notes 6, 13)	25	50	75	-	50	75	-	50	75	-	kHz
TRANSIENT RESPONSE (Note 10)											
Rise Time (Notes 3, 7, 8, 9)	25	-	30	60	-	30	60	-	30	60	ns
Overshoot (Notes 3, 7, 8, 9)	25	-	25	40	-	25	40	-	25	40	%
Slew Rate (Notes 3, 7, 9, 14)	25	± 4	± 7	-	± 4	± 7	-	± 4	± 7	-	V/ μs
Settling Time (Notes 3, 7, 15)	25	-	1.5	-	-	1.5	-	-	1.5	-	μs

HA-2600, HA-2602, HA-2605

Electrical Specifications $V_{SUPPLY} = \pm 15V$, Unless Otherwise Specified (Continued)

PARAMETER	TEMP. (°C)	HA-2600-2			HA-2602-2			HA-2605-9 HA-2605-5			UNITS
		MIN	TYP	MAX	MIN	TYP	MAX	MIN	TYP	MAX	
POWER SUPPLY CHARACTERISTICS											
Supply Current	25	-	3	3.7	-	3	4	-	3	4	mA
Power Supply Rejection Ratio (Note 11)	Full	80	90	-	74	90	-	74	90	-	dB

NOTES:

2. Typical and minimum specifications for -9 are identical to those of -5. All maximum specifications for -9 are identical to those of -5 except for Full Temperature Bias and Offset Currents, which are 70nA Max.
3. $R_L = 2k\Omega$.
4. $V_{CM} = \pm 10V$.
5. $V_{OUT} < 90mV$.
6. $V_{OUT} = \pm 10V$.
7. $C_L = 100pF$.
8. $V_{OUT} = \pm 200mV$.
9. $A_V = +1$.
10. See Transient Response Test Circuits and Waveforms.
11. $\Delta V_S = \pm 5V$.
12. This parameter value guaranteed by design calculations.
13. Full Power Bandwidth guaranteed by slew rate measurement: $FPBW = \frac{Slew\ Rate}{2\pi V_{PEAK}}$.
14. $V_{OUT} = \pm 5V$
15. Settling time is characterized at $A_V = -1$ to 0.1% of a 10V step.

Test Circuits and Waveforms

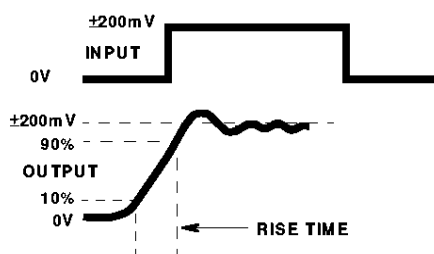

FIGURE 1. TRANSIENT RESPONSE

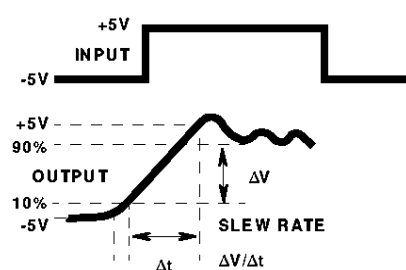

FIGURE 2. SLEW RATE

NOTE: Measured on both positive and negative transitions from 0V to +200mV and 0V to -200mV at the output.

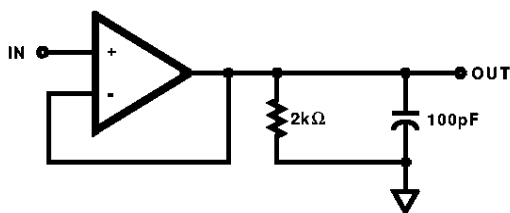
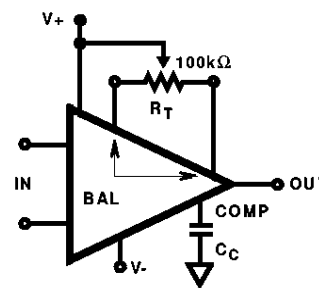

FIGURE 3. SLEW RATE AND TRANSIENT RESPONSE TEST CIRCUIT



NOTE: Tested offset adjustment range is $|V_{OS} + 1mV|$ minimum referred to output. Typical ranges are $\pm 10mV$ with $R_T = 100k\Omega$.

FIGURE 4. SUGGESTED V_{OS} ADJUSTMENT AND COMPENSATION HOOK UP

Schematic Diagram

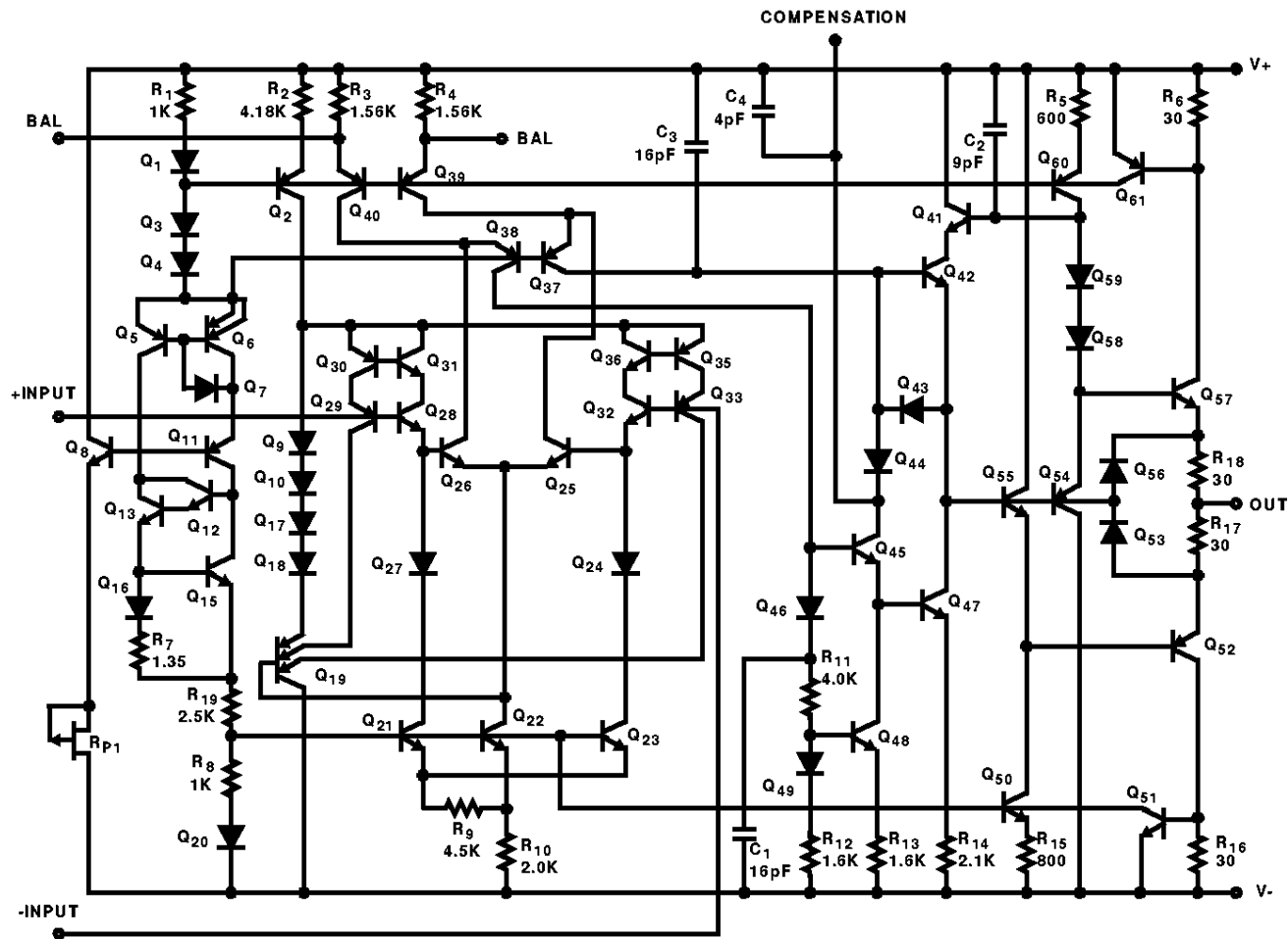

Typical Applications

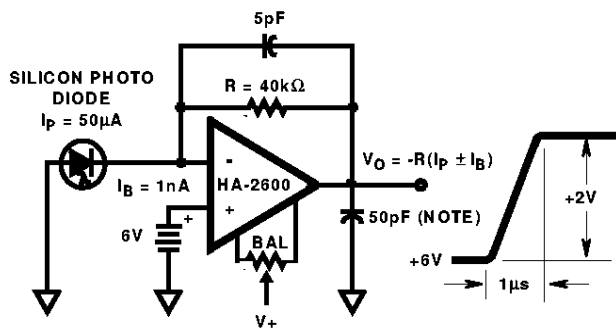

FEATURES:

1. Constant cell voltage.
2. Minimum bias current error.

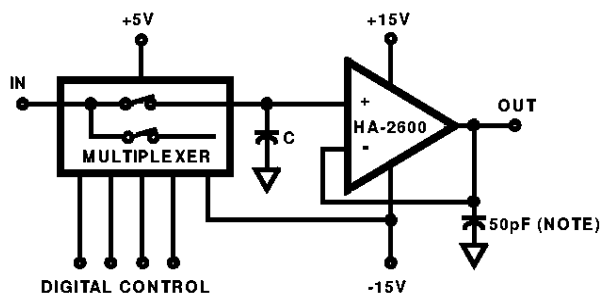

$$\text{DRIFT RATE} = \frac{I_{\text{BIAS}}}{C}$$

If $C = 1000\text{pF}$
Then $\text{DRIFT} = 0.01\text{V}/\mu\text{s}$ (Max)

NOTE: A small load capacitance is recommended in all applications where practical to prevent possible high frequency oscillations resulting from external wiring parasitics. Capacitance up to 100pF has negligible effect on the bandwidth or slew rate.

FIGURE 5. PHOTO CURRENT TO VOLTAGE CONVERTER

FIGURE 6. SAMPLE AND HOLD

Typical Applications (Continued)

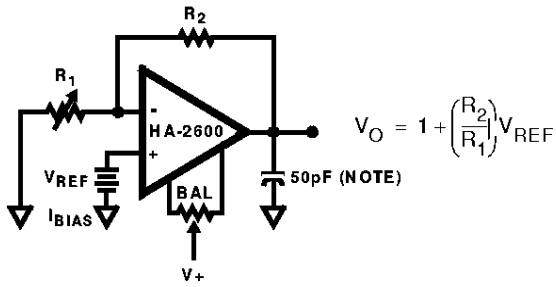

FEATURES:

1. Minimum bias current in reference cell.
2. Short Circuit Protection.

NOTE: A small load capacitance is recommended in all applications where practical to prevent possible high frequency oscillations resulting from external wiring parasitics. Capacitance up to 100pF has negligible effect on the bandwidth or slew rate.

FIGURE 7. REFERENCE VOLTAGE AMPLIFIER

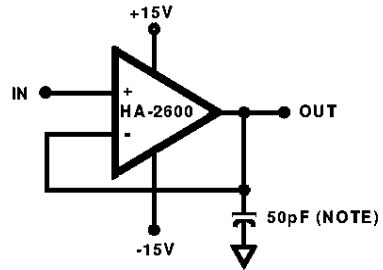

FEATURES

1. $Z_{IN} = 10^{12}\Omega$ (Min).
2. $Z_{OUT} = 0.01\Omega$ (Max), B.W. = 12MHz (Typ).
3. Slew Rate = 4V/ μ s (Min), Output Swing = $\pm 10V$ (Min) to 50kHz.

FIGURE 8. VOLTAGE FOLLOWER

Typical Performance Curves $V_S = \pm 15V$, $T_A = 25^\circ C$, Unless Otherwise Specified

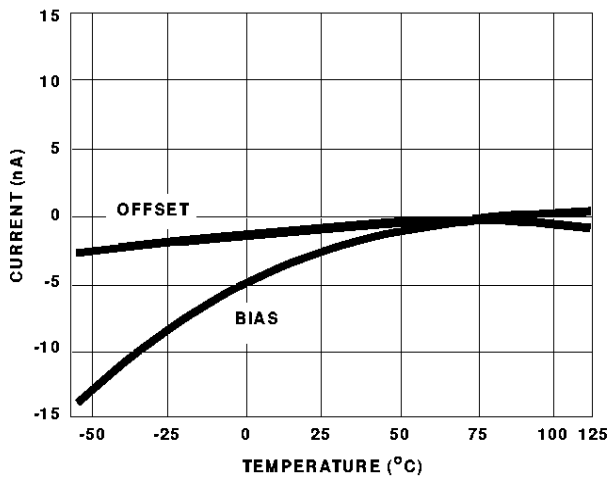

FIGURE 9. INPUT BIAS CURRENT AND OFFSET CURRENT vs TEMPERATURE

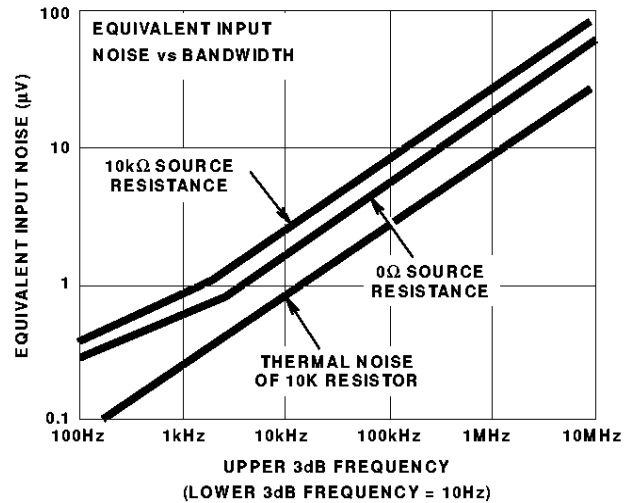

FIGURE 10. BROADBAND NOISE CHARACTERISTICS

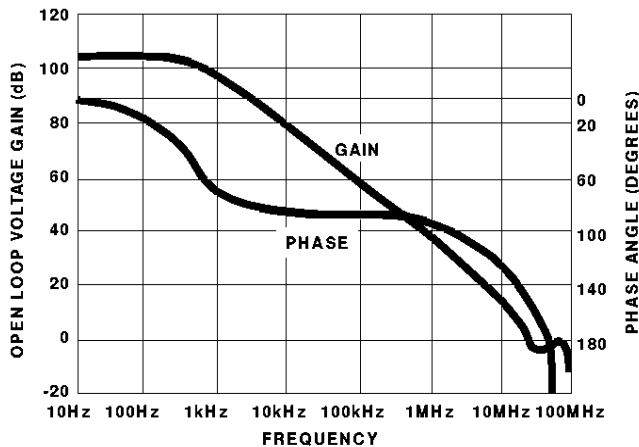

FIGURE 11. OPEN LOOP FREQUENCY RESPONSE

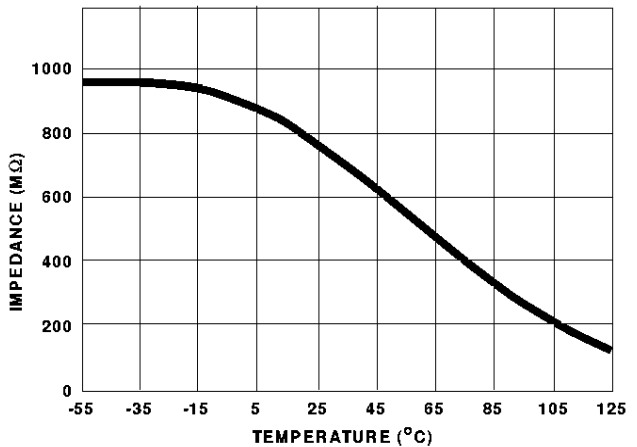

FIGURE 12. INPUT IMPEDANCE vs TEMPERATURE (100Hz)

Typical Performance Curves $V_S = \pm 15V, T_A = 25^\circ C$, Unless Otherwise Specified (Continued)

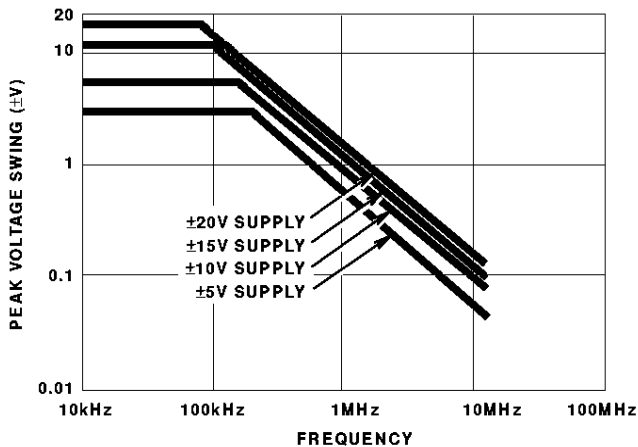
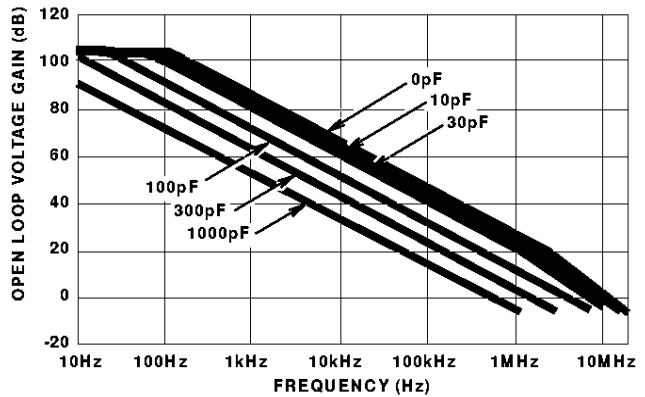

FIGURE 13. OUTPUT VOLTAGE SWING vs FREQUENCY



NOTE: External compensation components are not required for stability, but may be added to reduce bandwidth if desired. If External Compensation is used, also connect 100pF capacitor from output to ground.

FIGURE 14. OPEN LOOP FREQUENCY RESPONSE FOR VARIOUS VALUES OF CAPACITORS FROM COMPENSATION PIN TO GROUND

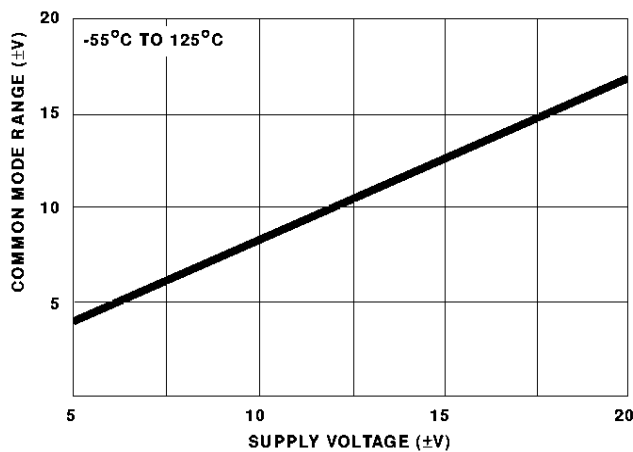

FIGURE 15. COMMON MODE VOLTAGE RANGE vs SUPPLY VOLTAGE

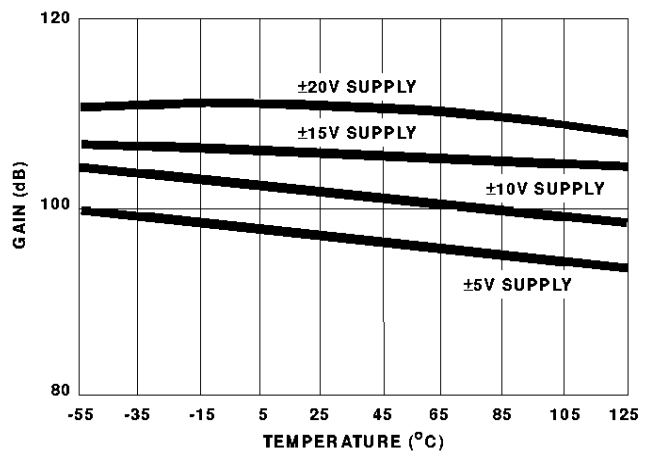

FIGURE 16. OPEN LOOP VOLTAGE GAIN vs TEMPERATURE

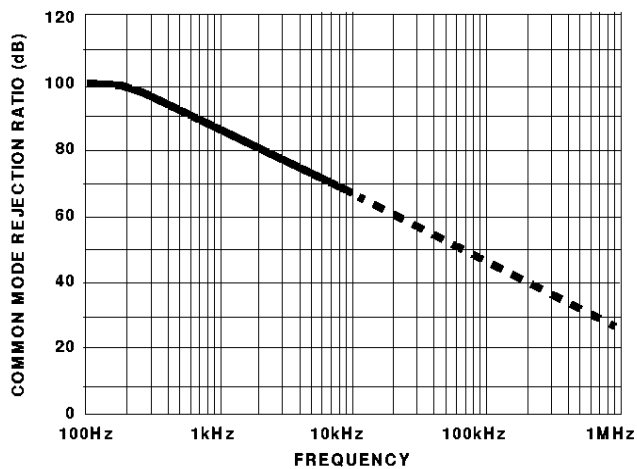

FIGURE 17. COMMON MODE REJECTION RATIO vs FREQUENCY

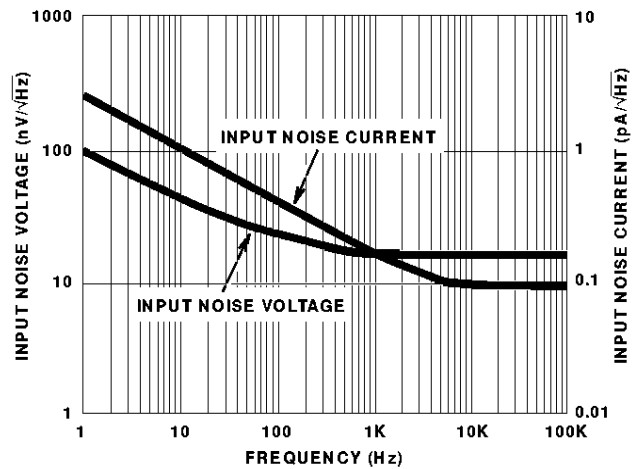

FIGURE 18. NOISE DENSITY vs FREQUENCY

HA-2600, HA-2602, HA-2605

Die Characteristics

DIE DIMENSIONS:

69 mils x 56 mils x 19 mils
1750 μ m x 1420 μ m x 483 μ m

METALLIZATION:

Type: Al, 1% Cu
Thickness: 16k \AA \pm 2k \AA

SUBSTRATE POTENTIAL (Powered Up):

Unbiased

PASSIVATION:

Type: Nitride (Si_3N_4) over Silox (SiO_2 , 5% Phos.)
Silox Thickness: 12k \AA \pm 2k \AA
Nitride Thickness: 3.5k \AA \pm 1.5k \AA

TRANSISTOR COUNT:

140

PROCESS:

Bipolar Dielectric Isolation

Metallization Mask Layout

HA-2600, HA-2602, HA-2605

