

APPLICATIONS

- Compassing
- Navigation Systems
- Attitude Reference
- Traffic Detection
- Medical Devices
- Non-Contact Switch

1 & 2 Axis Magnetoresistive Microcircuits

HMC1001 / 1002
HMC1021 / 1022

Configured as a 4-element wheatstone bridge, these highly sensitive sensors convert magnetic fields to a differential output voltage, capable of sensing magnetic fields as low as 30 μ gauss. These MRs offer a small, low cost, high sensitivity and high reliability solution for low field magnetic sensing.

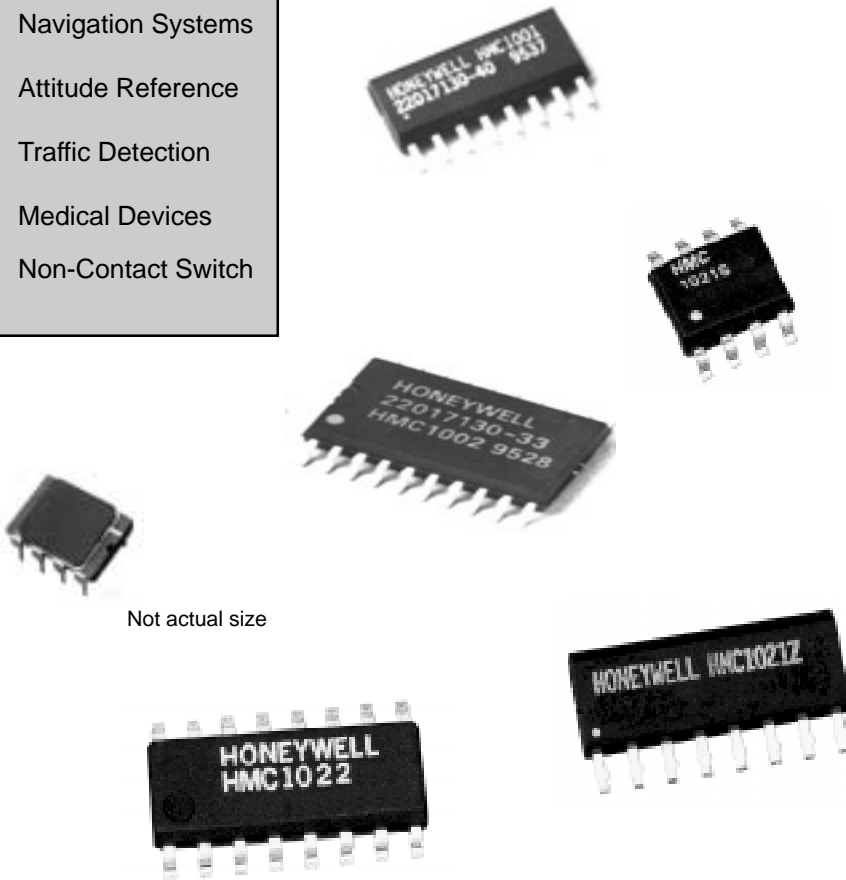

FEATURES AND BENEFITS

Wide Field Range Field range up to ± 6 gauss, (earth's field = 0.5 gauss)

Small Package

- Designed for 1- and 2-axis to work together to provide 3-axis (x, y, z) sensing
- 1-axis part in an 8-pin SIP or an 8-pin SOIC or a ceramic 8-pin DIP package
- 2-axis part in a 16-pin or 20-pin SOIC package

Solid State These small devices reduce board assembly costs, improve reliability and ruggedness compared to mechanical fluxgates.

On-Chip Coils Patented on-chip set/reset straps to reduce effects of temperature drift, non-linearity errors and loss of signal output due to the presence of high magnetic fields
Patented on-chip offset straps for elimination of the effects of hard iron distortion

Cost Effective The sensors were specifically designed to be affordable for high volume OEM applications.

HMC10XX FAMILY

HMC1001/1002 SPECIFICATIONS

Characteristic	Conditions	Min	Typ	Max	Unit
Bridge Supply (4)	Vbridge referenced to GND		5	10	Volts
Bridge Resistance	Bridge current = 10mA	600	850	1200	ohm
Operating Temperature (4)	Ambient	-40		85	° C
Storage Temperature (4)	Ambient, unbiased	-55		125	° C
Field Range (1) (2) (4)	Full scale (FS), total applied field	-2		+2	gauss
Linearity Error (1) (2) (4)	Best fit straight line (at 25° C)	±1 gauss ±2 gauss	0.1 1	0.5 2	%FS
Hysteresis Error (1) (2) (4)	3 sweeps across ±2 gauss @ 25° C		0.05	0.10	%FS
Repeatability Error (1) (2) (4)	3 sweeps across ±2 gauss @ 25° C		0.05	0.10	%FS
S/R Repeatability (1) S/R Repeatability (2)	Output variation after alternate S/R pulses		2	10 100	µV
Bridge Offset	Offset = (OUT+) - (OUT-), Field=0 gauss after Set pulse, Vbridge=8V	-60	-15	30	mV
Sensitivity (1) (2)	At I _{OFFSET} = ±50mA, Vbridge=8V	2.5	3.2	4.0	mV/V/gauss
Noise Density	Noise at 1Hz, Vbridge=5V		29		nV/ Hz
Resolution	Bandwidth=10Hz, Vbridge=5V		27		µgauss
Bandwidth	Magnetic signal (lower limit = DC)		5		MHz
OFFSET Strap	Measured from OFFSET+ to OFFSET-		2.5	3.5	ohm
OFFSET Strap ΩTempco	T _A =-40 to 85° C		3900		ppm/° C
OFFSET Field (4)	Field applied in sensitive direction	46	51	56	mA/gauss
Set/Reset Strap	Measured from S/R+ to S/R-		1.5	1.8	ohm
Set/Reset Current (2) (3) (4)	Current at 0.1% duty cycle, or less	3.0	3.2	5	Amp
Disturbing Field (4)	Sensitivity starts to degrade. Use S/R pulse to restore sensitivity.	3			gauss
Sensitivity Tempco	T _A =-40 to 85° C Vbridge=8V Ibridge=5mA		-3000 -600		ppm/° C
Bridge Offset Tempco	T _A =-40 to 85° C Ibridge=5mA no Set/Reset with Set/Reset		±300 ±10		ppm/° C
Resistance Tempco	Vbridge=8V, -40 to 85° C		2500		ppm/° C
Cross-Axis Effect	Cross field=1gauss (see AN-205) no Set/Reset with Set/Reset		±3 +0.5		%FS
Max. Exposed Field (4)	No perming effect on zero reading			100	gauss
Weight	HMC1001 HMC1002		0.14 0.53		gram

(1) V_{Bridge} = 4.3V, I_{S/R} = 3.2A, T = 25°C. V_{OUT} = V_{SET} - V_{RESET}

(2) If V_{Bridge} = 8.0V, I_{S/R} = 2.0A, T = 25°C, lower S/R current leads to greater output variation.

(3) Effective current from power supply is less than 1mA.

(4) Not tested, guaranteed by characterization.

Units: 1 gauss (g) = 1 Ørsted (in air), = 79.58 A/m, 1G = 10E-4 Tesla, 1G = 10E5 gamma.

HMC1021/1022 SPECIFICATIONS

Characteristic	Conditions	Min	Typ	Max	Unit
Bridge Supply	Vbridge referenced to GND	3	5	12	Volts
Bridge Resistance	Bridge current = 5mA	800	1100	1300	Ω
Operating Temperature	Ambient	-40		85	$^{\circ}$ C
Storage Temperature	Ambient, unbiased	-55		125	$^{\circ}$ C
Field Range	Full scale (FS) — total applied field	-6		+6	gauss
Linearity Error	Best fit straight line (at 25 $^{\circ}$ C) ± 1 gauss ± 3 gauss ± 6 gauss		0.05 0.4 1.6		%FS
Hysteresis Error	3 sweeps across ± 3 gauss @ 25 $^{\circ}$ C		0.08		%FS
Repeatability Error	3 sweeps across ± 3 gauss @ 25 $^{\circ}$ C		0.08		%FS
Gain Error	Applied field for zero reading		0.05	0.10	%FS
Bridge Offset	Offset = (OUT+) - (OUT-), Field=0 gauss after Set pulse, Vbridge=5V	-10	± 2.5	+10	mV
Sensitivity	At Vbridge=5V	0.8	1.0	1.2	mV/V/gauss
Noise Density	Noise at 1Hz, Vbridge=5V		48		nV/ $\sqrt{\text{Hz}}$
Resolution	Bandwidth=10Hz, Vbridge=5V		85		μ gauss
Bandwidth	Magnetic signal (lower limit = DC)		5		MHz
OFFSET Strap	Measured from OFFSET+ to OFFSET-	40	50	60	Ω
OFFSET Strap Ω Tempco	TA=-40 to 85 $^{\circ}$ C		3900		ppm/ $^{\circ}$ C
OFFSET Field	Field applied in sensitive direction	4.0	4.6	6.0	mA/gauss
Set/Reset Strap	Measured from S/R+ to S/R-	6	7.7	9	Ω
Set/Reset Current	Current at 0.1% duty cycle, or less	0.5	0.5	4.0	Amp
Disturbing Field	Sensitivity starts to degrade. Use S/R pulse to restore sensitivity.	20			gauss
Sensitivity Tempco	TA=-40 to 85 $^{\circ}$ C Vbridge=5V Ibridge=5mA	-2800	-3000 -600	-3200	ppm/ $^{\circ}$ C
Bridge Offset Tempco	TA=-40 to 85 $^{\circ}$ C Ibridge=5mA no Set/Reset with Set/Reset		± 500 ± 10		ppm/ $^{\circ}$ C
Resistance Tempco	Vbridge=5V, -40 to 85 $^{\circ}$ C		2500		ppm/ $^{\circ}$ C
Cross-Axis Effect	Cross field=1gauss (see AN-205) Happlied= ± 1 gauss		+0.3		%FS
Max. Exposed Field	No perming effect on zero reading			200	gauss
Set/Reset (1)	S/R current ≥ 0.5 Amps			30	μ V

(1) Not tested, guaranteed by design.

Units: 1 gauss (G) = 1 Oersted (in air), 1G = 79.58 A/m,
1G = 10E-4 Tesla, 1G = 10E5 gamma

HMC10XX FAMILY

KEY PERFORMANCE DATA

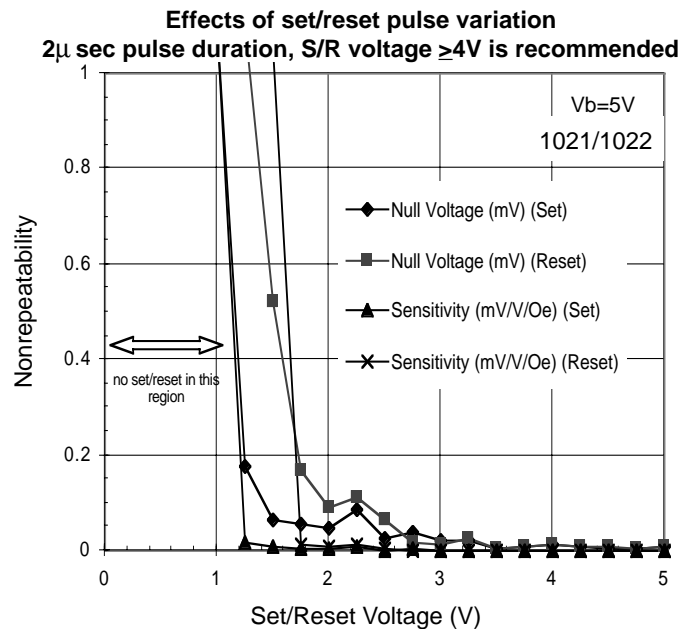
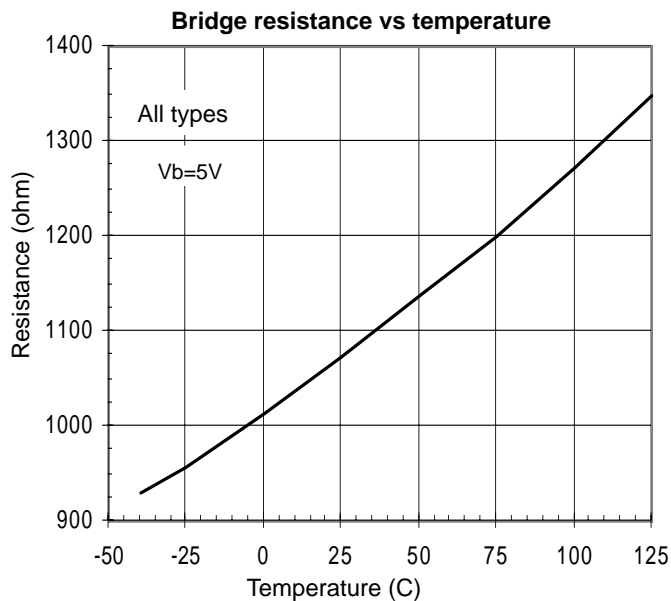
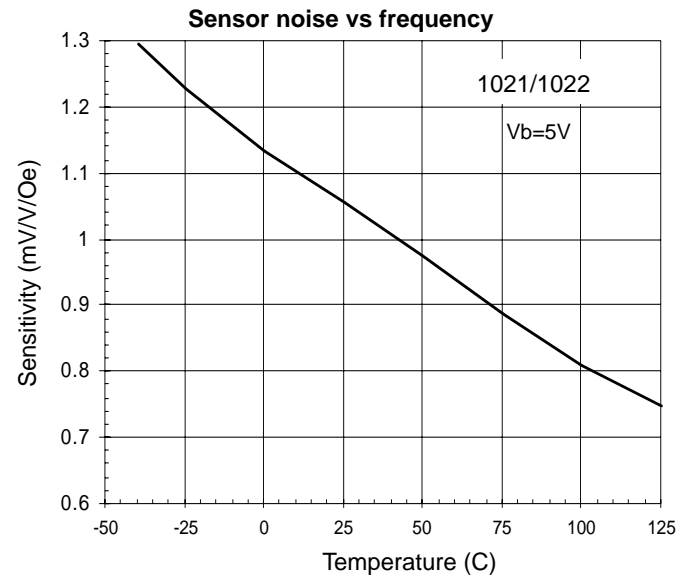
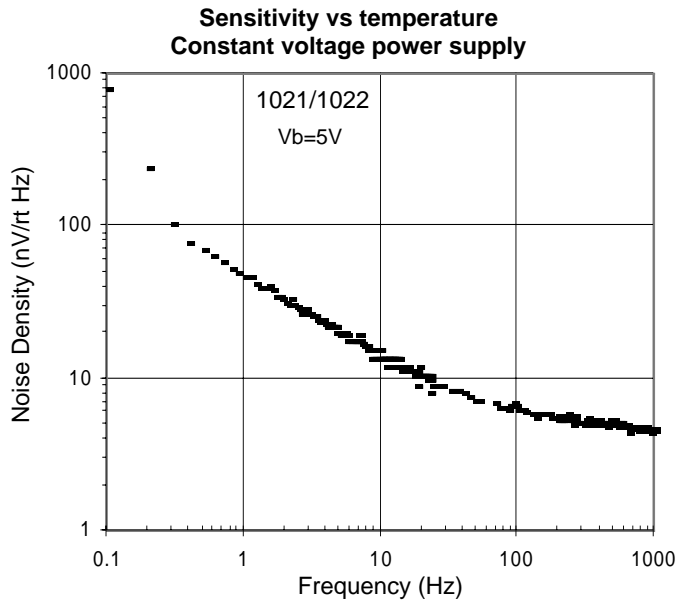
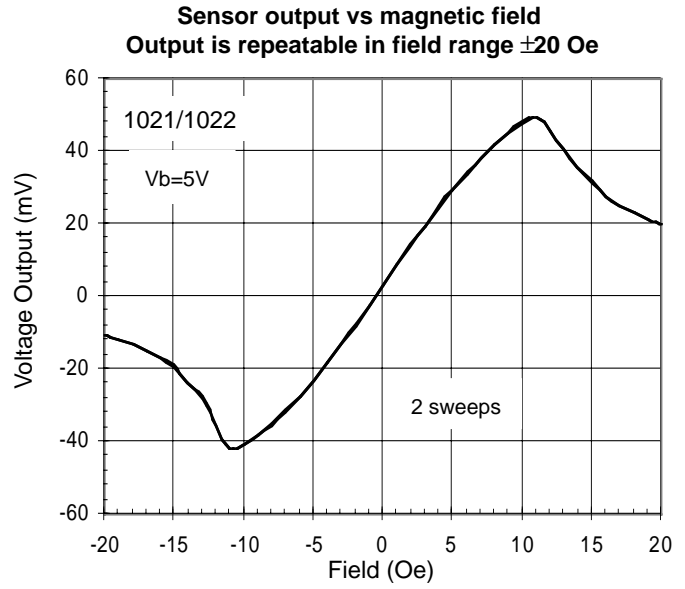
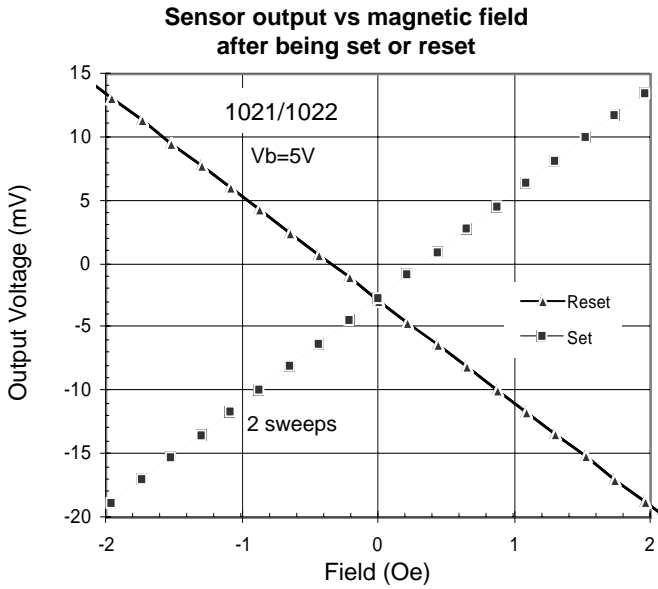

PACKAGE / PINOUT SPECIFICATIONS

HMC1002—Two-Axis MR Microcircuit

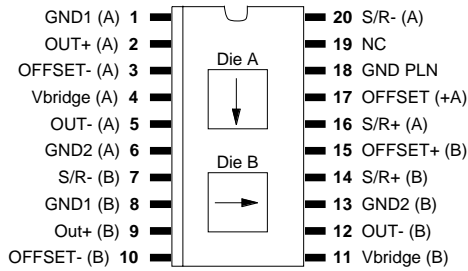

HMC1001—One Axis MR Microcircuit

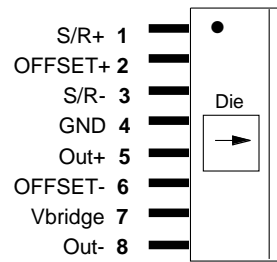

HMC1022—Two-Axis MR Circuit

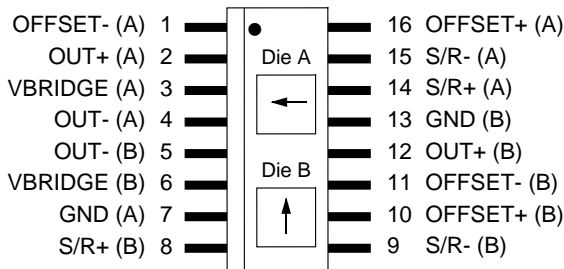

HMC1021S—One-Axis MR Circuit

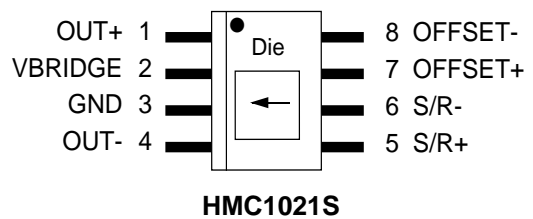

HMC1021D—One-Axis MR Circuit

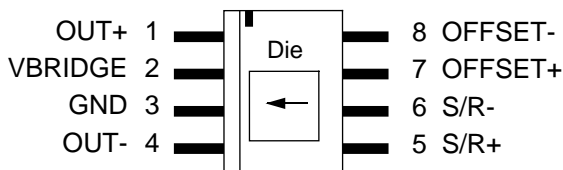

HMC1021Z—One-Axis MR Circuit

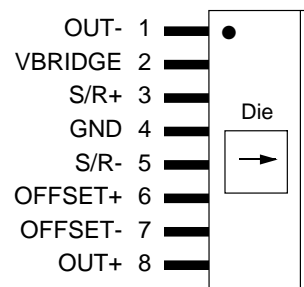

Arrow indicates direction of applied field that generates a positive output voltage after a SET pulse.

HMC10XX FAMILY

BASIC DEVICE OPERATION

Honeywell magnetoresistive sensors are simple resistive bridge devices (Figure 1) that only require a supply voltage to measure magnetic fields. When a voltage from 0 to 10 volts is connected to V_{bridge}, the sensor begins measuring any ambient, or applied, magnetic field in the sensitive axis. In addition to the bridge circuit, the transducer has two on-chip magnetically coupled straps—the OFFSET strap and the Set/Reset strap. These straps are patented by Honeywell and eliminate the need for external coils around the devices.

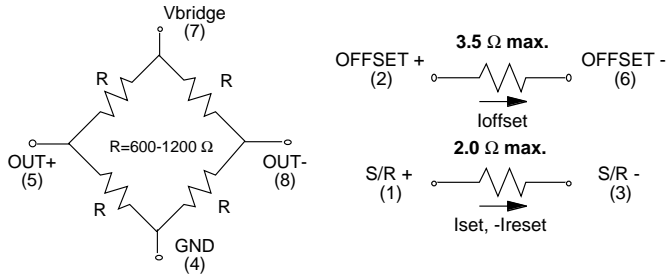

Figure 1—On-Chip components (HMC1001)

Magnetoresistive sensors are made of a nickel-iron (Permalloy) thin film deposited on a silicon wafer and patterned as a resistive strip. In the presence of an applied magnetic field, a change in the bridge resistance causes a corresponding change in voltage output.

An external magnetic field applied normal to the side of the film causes the magnetization vector to rotate and change angle. This in turn will cause the resistance value to vary ($\Delta R/R$) and produce a voltage output change in the Wheatstone bridge. This change in the Permalloy resistance is termed the *magnetoresistive effect* and is directly related to the angle of the current flow and the magnetization vector.

During manufacture, the easy axis (preferred direction of magnetic field) is set to one direction along the length of the film. This allows the maximum change in resistance for an applied field within the permalloy film. However, the influence of a strong magnetic field (more than 10 gauss) along the easy axis could upset, or flip, the polarity of film magnetization, thus changing the sensor characteristics. Following such an upset field, a strong restoring magnetic field must be applied momentarily to restore, or set, the sensor characteristics. This effect will be referred to as applying a set pulse or reset pulse. Polarity of the bridge output signal depends upon the direction of this internal film magnetization and is symmetric about the zero field output.

The OFFSET strap allows for several modes of operation when a dc current is driven through it.

- An unwanted magnetic field can be subtracted out
- The bridge offset can be set to zero
- The bridge output can drive the OFFSET strap to cancel out the field being measured in a closed loop configuration
- The bridge gain can be auto-calibrated in the system on command.

The Set/Reset (S/R) strap can be pulsed with a high current to:

- Force the sensor to operate in the high sensitivity mode
- Flip the polarity of the output response curve
- Be cycled during normal operation to improve linearity and reduce cross-axis effects and temperature effects.

The output response curves shown in Figure 2 illustrate the effects of the S/R pulse. When a SET current pulse (I_{set}) is driven into the SR+ pin, the output response follow the curve with the positive slope. When a RESET current pulse (I_{reset}) is driven into the SR- pin, the output response follow the curve with the negative slope. These curves are mirror images about the origin except for two offset effects.

In the vertical direction, the bridge offset shown in Figure 2, is around -25mV. This is due to the resistor mismatch during the manufacture process. This offset can be trimmed to zero by one of several techniques. The most straight forward technique is to add a shunt (parallel) resistor across one leg of the bridge to force both outputs to the same voltage. This must be done in a zero magnetic field environment, usually in a zero gauss chamber.

The offset of Figure 2 in the horizontal direction is referred to here as the external offset. This may be due to a nearby ferrous object or an unwanted magnetic field that is interfering with the applied field being measured. A dc current in the OFFSET strap can adjust this offset to zero. Other methods such as shielding the unwanted field can also be used to zero the external offset. The output response curves due to the SET and RESET pulses are reflected about these two offsets.

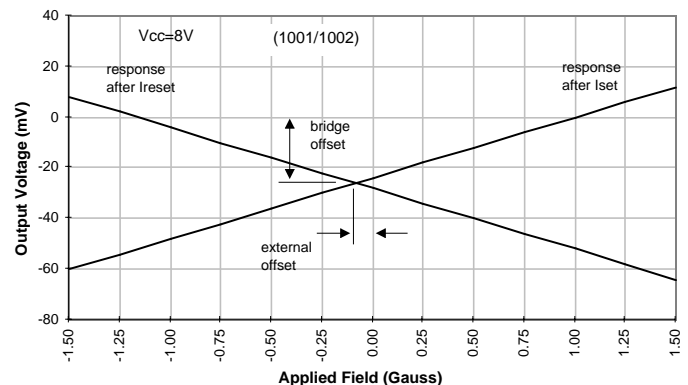

Figure 2—Output Voltage vs. Applied Magnetic Field

WHAT IS OFFSET STRAP?

Any ambient magnetic field can be canceled by driving a defined current through the OFFSET strap. This is useful for eliminating the effects of stray hard iron distortion of the earth's magnetic field. For example, reducing the effects of a car body on the earth's magnetic field in an automotive compass application. If the MR sensor has a fixed position within the automobile, the effect of the car on the earth's magnetic field can be approximated as a shift, or offset, in this field. If this shift in the earth's field can be determined, then it can be compensated for by applying an equal and opposite field using the OFFSET strap. Another use for the OFFSET strap would be to drive a current through the strap that will exactly cancel out the field being measured. This is called a closed loop configuration where the current feedback signal is a direct measure of the applied field.

The field offset strap (OFFSET+ and OFFSET-) will generate a magnetic field in the same direction as the applied field being measured. This strap provides a 1 Oersted (Oe) field per 50 mA of current through it. (Note: 1 gauss=1 Oersted in air). That is, if 25 mA were driven from the OFFSET+ pin to the OFFSET- pin, a field of 0.5 gauss would be added to any ambient field being measured. Also, a current of -25 mA would subtract 0.5 gauss from the ambient field. The OFFSET strap looks like as a nominal 2.5 ohm resistance between the OFFSET+ and OFFSET- pins.

The OFFSET strap can be used as a feedback element in a closed loop circuit. Using the OFFSET strap in a current feedback loop can produce desirable results for measuring magnetic fields. To do this, connect the output of the bridge amplifier to a current source that drives the OFFSET strap. Using high gain and negative feedback in the loop, this will drive the MR bridge output to zero, (OUT+) = (OUT-). This method gives extremely good linearity and temperature characteristics. The idea here is to always operate the MR bridge in the balanced resistance mode. That is, no matter what magnetic field is being measured, the current through the OFFSET strap will cancel it out. The bridge always "sees" a zero field condition. The resultant current used to cancel the applied field is a direct measure of that field strength and can be translated into the field value.

The OFFSET strap can also be used to auto-calibrate the MR bridge while in the application during normal operation. This is useful for occasionally checking the bridge gain for that axis or to make adjustments over a large temperature swing. This can be done during power-up or anytime during normal operation. The concept is simple; take two point along a line and determine the slope of that line—the gain. When the bridge is measuring a steady applied magnetic field the output will remain constant. Record the reading for the steady field and call it H1. Now apply a known current through the OFFSET strap and record that reading as H2. The current through the OFFSET strap will cause a change

in field the MR sensor measures—call that the delta applied field (ΔH_a). The MR sensor gain is then computed as:

$$\text{MRgain} = (H_2 - H_1) / \Delta H_a$$

There are many other uses for the OFFSET strap than those described here. The key point is that ambient field and the OFFSET field simply add to one another and are measured by the MR sensor as a single field.

NOISE CHARACTERISTICS

The noise density curve for a typical MR sensor is shown in Figure 3. The 1/f slope has a corner frequency near 10 Hz and flattens out to 3.8 nV/ $\sqrt{\text{Hz}}$. This is approximately equivalent to the Johnson noise (or white noise) for an 850 Ω resistor—the typical bridge resistance. To relate the noise density voltage in Figure 3 to the magnetic fields, use the following expressions:

For $V_{\text{supply}}=5\text{V}$ and $\text{Sensitivity}=3.2\text{mV/V/gauss}$,
 Bridge output response = 16 mV/gauss
 or 16 nV/ μgauss

The noise density at 1Hz \approx 30 nV/ $\sqrt{\text{Hz}}$
 and corresponds to 1.8 $\mu\text{gauss}/\sqrt{\text{Hz}}$

For the noise components, use the following expressions:

1/f noise(0.1-10Hz) = $30 * \sqrt{(\ln(10/.1))}$ nV
 64 nV (rms)
 4 μgauss (rms)
 27 μgauss (p-p)

white noise (BW=1KHz) = $3.8 * \sqrt{\text{BW}}$ nV
 120 nV (rms)
 50 μgauss (p-p)

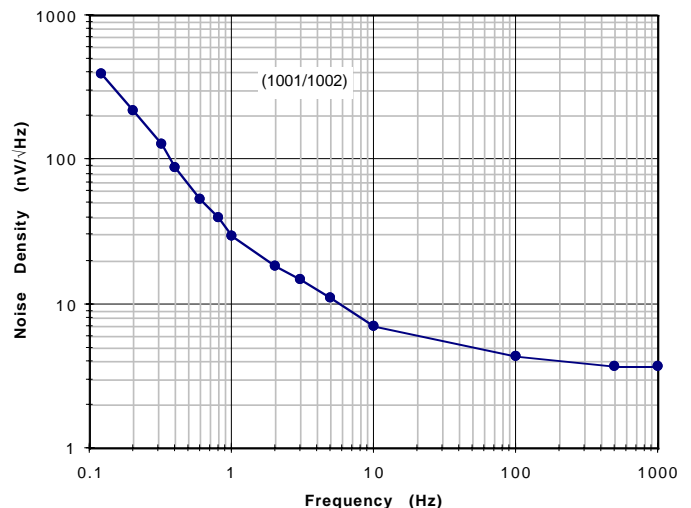

Figure 3—Typical Noise Density Curve

HMC10XX FAMILY

WHAT IS SET/RESET STRAP?

Most low field magnetic sensors will be affected by large magnetic disturbing fields (>4 gauss) that may lead to output signal degradation. In order to reduce this effect, and maximize the signal output, a magnetic switching technique can be applied to the MR bridge that eliminates the effect of past magnetic history. The purpose of the Set/Reset (S/R) strap is to restore the MR sensor to its high sensitivity state for measuring magnetic fields. This is done by pulsing a large current through the S/R strap. The Set/Reset (S/R) strap looks like a resistance between the SR+ and SR- pins. This strap differs from the OFFSET strap in that it is magnetically coupled to the MR sensor in the cross-axis, or insensitive, direction. Once the sensor is set (or reset), low noise and high sensitivity field measurement can occur. In the discussion that follows, the term “set” refers to either a set or reset current.

The on-chip S/R should be pulsed with a current to realign, or “flip”, the magnetic domains in the transducer. This pulse can be as short as two microsecond and on average consumes less than 1 mA dc when pulsing continuously. The duty cycle can be selected for a 2 μ sec pulse every 50 msec, or longer, to conserve power. The only requirement is that each pulse only drive in one direction. That is, if a +3.5 amp pulse is used to “set” the sensor, the pulse decay should not drop below zero current. Any undershoot of the current pulse will tend to “un-set” the sensor and the sensitivity will not be optimum.

Using the S/R strap, many effects can be eliminated or reduced that include: temperature drift, non-linearity errors, cross-axis effects, and loss of signal output due to the presence of a high magnetic fields. This can be accomplished by the following process:

- A current pulse, I_{set} , can be driven from the S/R+ to the S/R- pins to perform a “SET” condition. The bridge output can then be measured and stored as $V_{out(set)}$.
- Another pulse of equal and opposite current should be driven through the S/R pins to perform a “RESET” condition. The bridge output can then be measured and stored as $V_{out(reset)}$.
- The bridge output, V_{out} , can be expressed as: $V_{out} = [V_{out(set)} - V_{out(reset)}]/2$. This technique cancels out offset and temperature effects introduced by the electronics as well as the bridge temperature drift.

The magnitude of the S/R current pulse depends on the magnetic noise sensitivity of the application. If the minimum detectable field for a given application is roughly 500 μ gauss, then a 2.5 amp pulse (min) is adequate. If the minimum detectable field is less than 100 μ gauss, then a 3.5 amp pulse (min) is required. The circuit that generates the S/R pulse should be located close to the MR sensor and have good power and ground connections.

There are many ways to design the set/reset pulsing circuit, though, budgets and ultimate field resolution will determine which approach will be best for a given application. A simple set/reset circuit is shown in Figure 4.

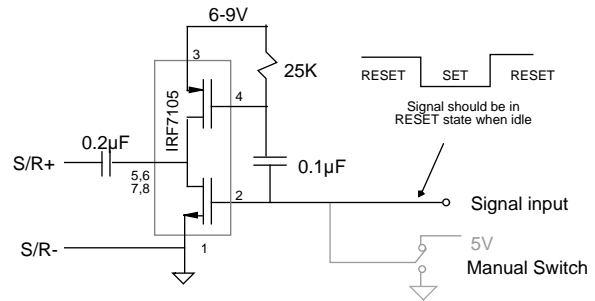

Figure 4—Single-Axis Set/Reset Pulse Circuit (1001)

The magnitude of the set/reset current pulse depends on the magnetic noise sensitivity of the system. If the minimum detectable field for a given application is roughly 500 μ gauss, then a 3 amp pulse (min) is adequate. If the minimum detectable field is less than 100 μ gauss, then a 4 amp pulse (min) is required.

The set/reset straps on the Honeywell magnetic sensors are labeled S/R+ and S/R-. There is no polarity implied since this is simply a metal strap resistance of typically 1.5 Ω per sensor. Therefore, for a three axis system, the total series strap resistance is typically 4.5 Ω .

If three axis are used, it is recommended that the straps are connected in series to insure the same current pulse flows through all three sensors. Assuming the pulse drive circuitry has a source impedance of 0.5 Ω , the set/reset current pulse will effectively drive a 5 Ω load. Now to generate a 3-4 amp minimum pulse into a 5 Ω load requires a 15-20V supply.

Single Clock Circuitry—Some form of clock is needed to trigger the set and reset pulses (Figure 5) to create the switching signal. The circuit shown in Figure 7 can be used to create a strong (>4Amp) pulse. The diodes, resistors, capacitors and inverters basically create the TRS and the TSR delays. Now a single signal (Clock) can trigger a set or reset pulse. The minimum timing between the rising and falling edges of Clock are determined by the 25K Ω and 1nF time constant. That is, the minimum high and low time for Clock is $\approx 25 \mu\text{s}$.

Micro Processor—The circuit in Figure 8 generates a strong set/reset pulse (>4 Amp) under microprocessor control. The

SET and RESET signals are generated from a microprocessor and control the P and N channel HEXFET drivers (IRF7106). The purpose of creating the TRS and the TSR delays are to make sure that one HEXFET is off before the other one turns on. Basically, a break-before-make switching pattern. The current pulse is drawn from the 4.7 μF capacitor. If the 5V to 20V converter is used as shown in Figure 6, then the resultant noise and droop on the 16-20V supply is not an issue. But if the 16-20V supply is used elsewhere in the system, then a series dropping resistor ($\approx 500\Omega$) should be placed between the 4.7 μF capacitor and the supply. time constant. That is, the minimum high and low time for Clock is $\approx 25 \mu\text{s}$.

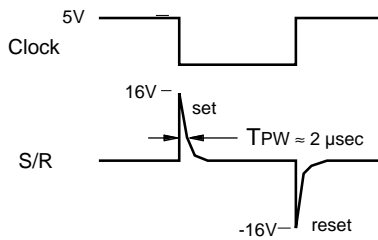

Figure 5—Single Clock Set/Reset Timing

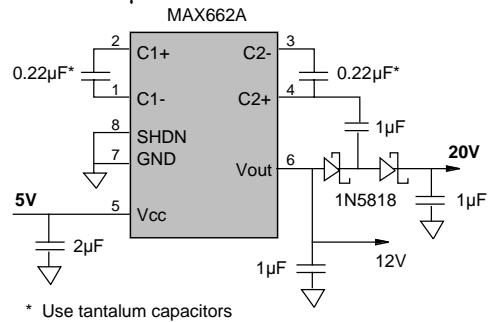

Figure 6—5V to 20V Converter

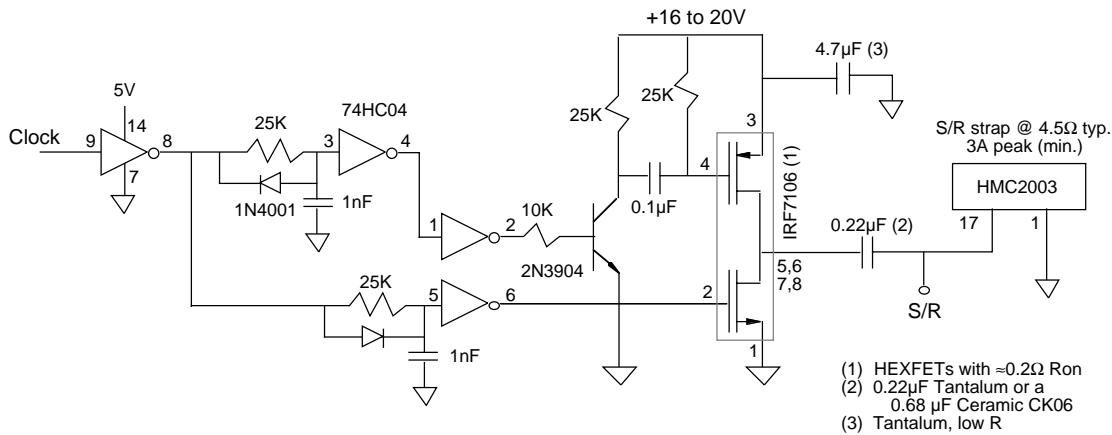

Figure 7—Single Clock Set/Reset Pulse Circuit (1001/1002)

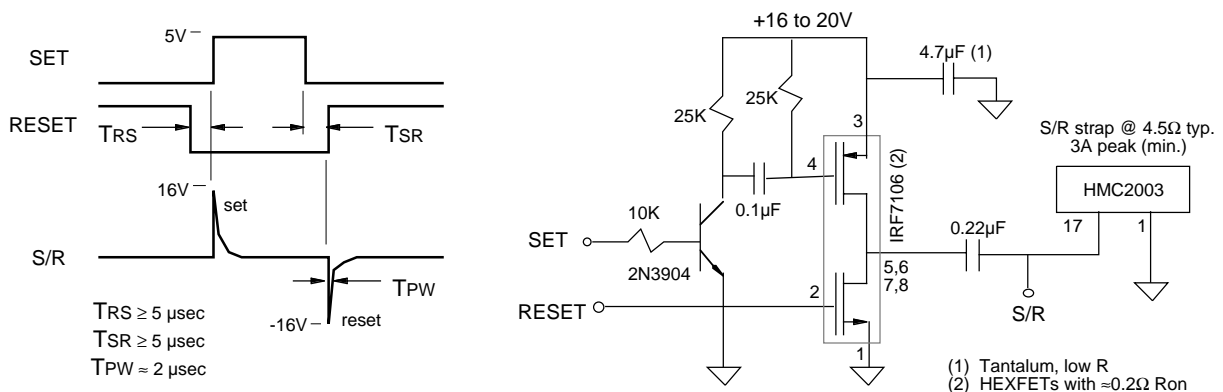

Figure 8—Set/Reset Circuit With Microprocessor Control(1001/1002)

HMC10XX FAMILY

Low Field Measurements—When measuring 100 μ gauss resolution or less, the permalloy film must be completely set, or reset, to insure low noise and repeatable measurements. A current pulse of 4 amps, or more, for just a couple microseconds will ensure this. The circuits in Figures 7 and 8 are recommended for applications that require low noise and high sensitivity magnetic readings.

Low Cost—For minimum field measurements above 500 μ gauss, a less elaborate pulsing circuit can be used. In both Figures 9 and 10, the pulse signal is switched using lower cost Darlington transistors and fewer components. This circuit may have a more limited temperature range depending on the quality of transistors selected. If accuracy is not an issue and cost is, then the reset only circuit in Figure 10 will work.

For any magnetic sensor application, if temperature drift is not an issue, then the reset pulse need only be occasionally applied. This will save power and enable the use of digital filtering techniques as shown in Figure 11. Circumstances for a reset pulse would be 1) power on or, 2) field over/under range condition. Any other time the sensor should perform normally.

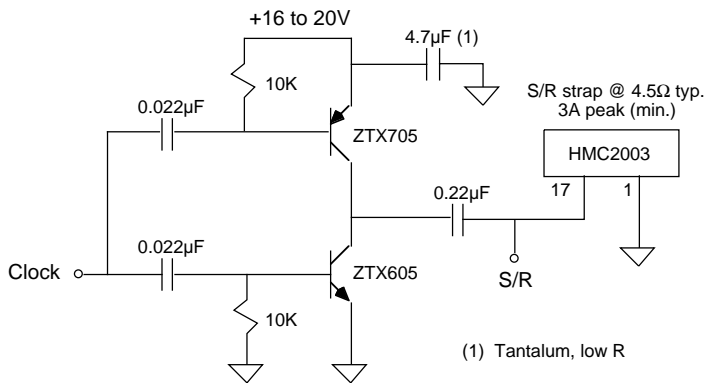

Figure 9—Single Clock Set/Reset Circuit(1001/1002)

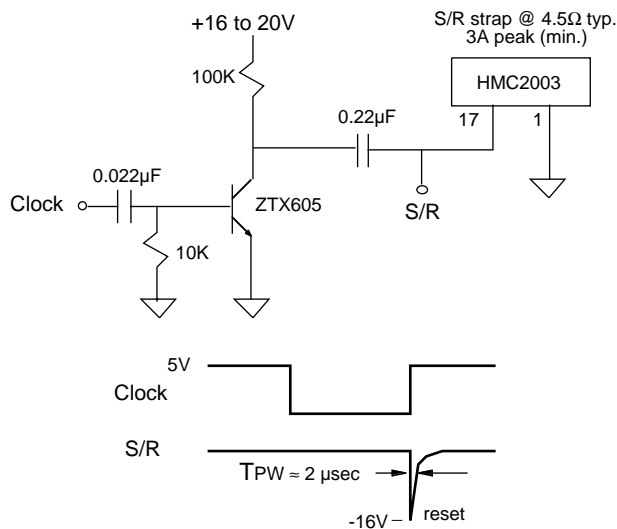

Figure 10—Single Clock Reset Only Circuit (1001/1002)

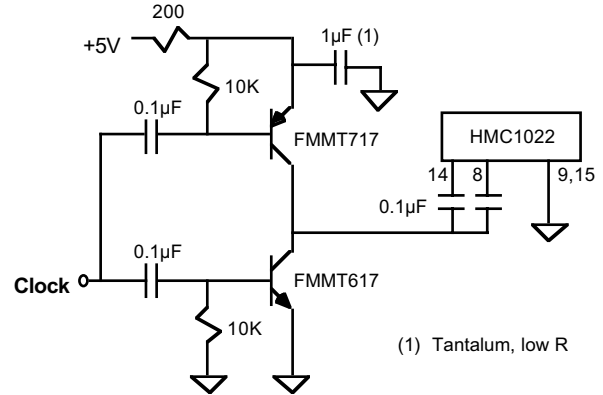

Figure 11—5V Circuit for SET/RESET (1021/1022)

The circuit in Figure 12 generates a strong set/reset pulse under a microprocessor clock driven control. A free running 555 timer can also be used to clock the circuit. The SET current pulse is drawn from the 4.7 μ F capacitor and a 200 ohm dropping resistor should be placed in series with the supply to reduce noise.

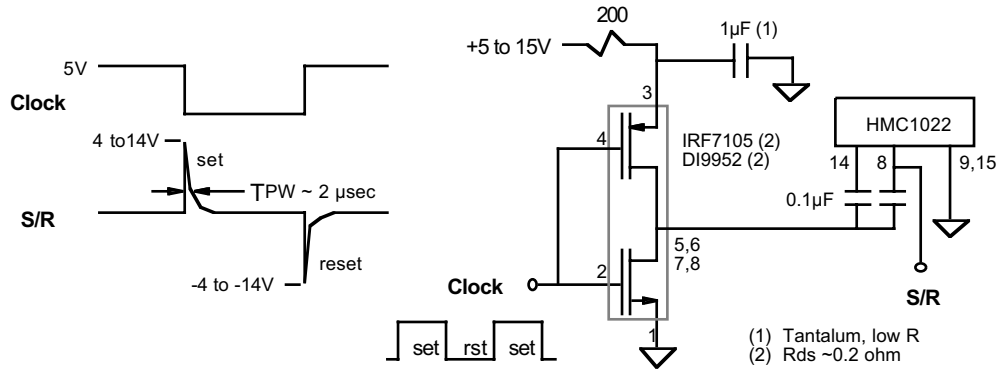

Figure 12—Set/Reset Pulse With Clock Control(1021/1022)

Low Power—For low power application, down to 3.3 volt supply, the circuit shown in Figure 14 can be used. These low threshold FETs provide low on-resistance (0.3W) at $V_{GS}=2.7V$. The set/reset pulsing does not need to be continuous. To save power, the SET pulse can be initially applied followed by a single RESET pulse. The offset (OS) can be calculated as:

$$OS = (V_{set} + V_{rst})/2$$

This offset term will contain the DC offset of both the sensor bridge and interface electronics, as well as the temperature drift of the bridge and interface electronics. Store this value and subtract it from all future bridge output readings. Once the bridge is RESET, it will remain in that state for years—or until a disturbing field (>20 gauss) is applied. A timer can be set, say every 10 minutes, to periodically update the offset term. A flow chart is shown in Figure 13 along with a timing diagram in Figure 14 to illustrate this process.

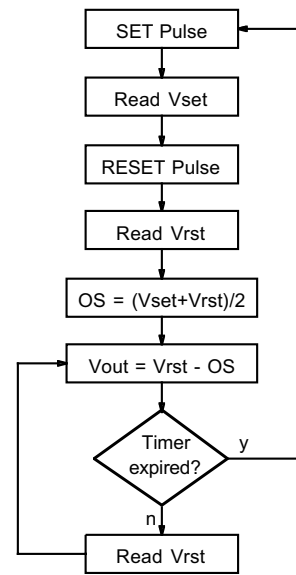

Figure 13—Low Power Set/Rst Flowchart

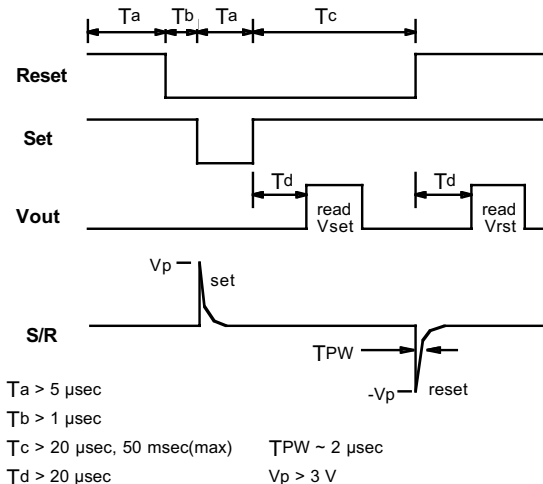

Figure 14—Single Clock Set/Reset Pulse Circuit (1021/1022)

HMC10XX FAMILY

Simple Circuit Application

The circuit in Figure 15 shows a simple magnetic sensor. This circuit acts as a proximity sensor and will turn on the LED when a magnet is brought within 0.25 to 0.5 inch of the sensor. The amplifier acts as a simple comparator and switches low when the HMC1001 bridge output exceeds

30mV. The magnet must be strong (200 gauss) and have one of its magnetic poles point along the sensitive direction of the sensor. This circuit can be used to detect a door open/closed status or the presence or absence of an item. Figures 16, 17 and 18 show other circuit examples.

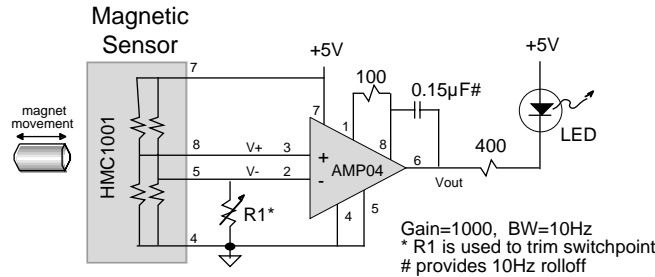

- Calibrate:
1. Trim R1 for (+V) - (-V) < 30mV
 2. Apply signal < 30mV, LED should be off.
 3. Apply signal > 30mV, LED should be on.

Figure 15—Magnetic Proximity Switch

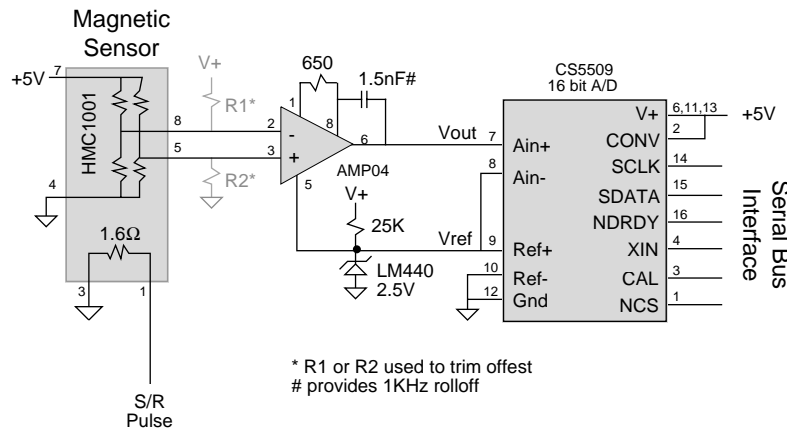

Figure 16—One-Axis Sensor With Digital Interface

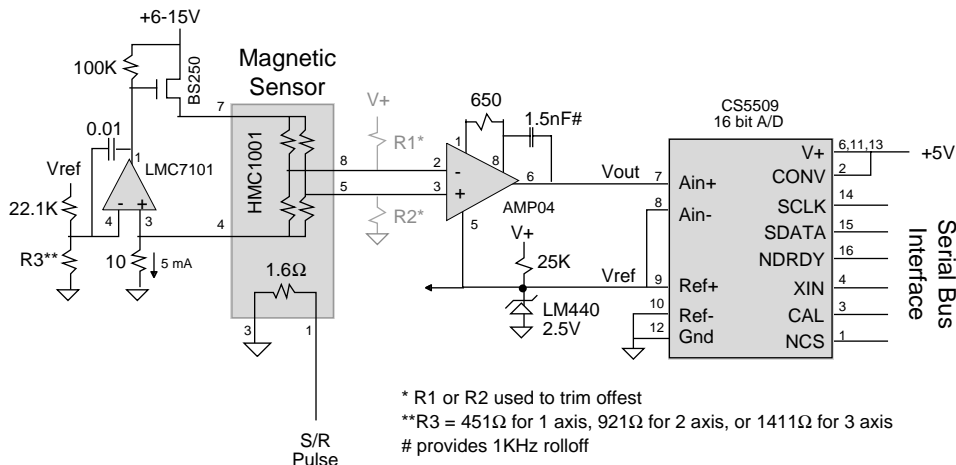

Figure 17—One-Axis Sensor With Constant Bridge Current and Digital Interface

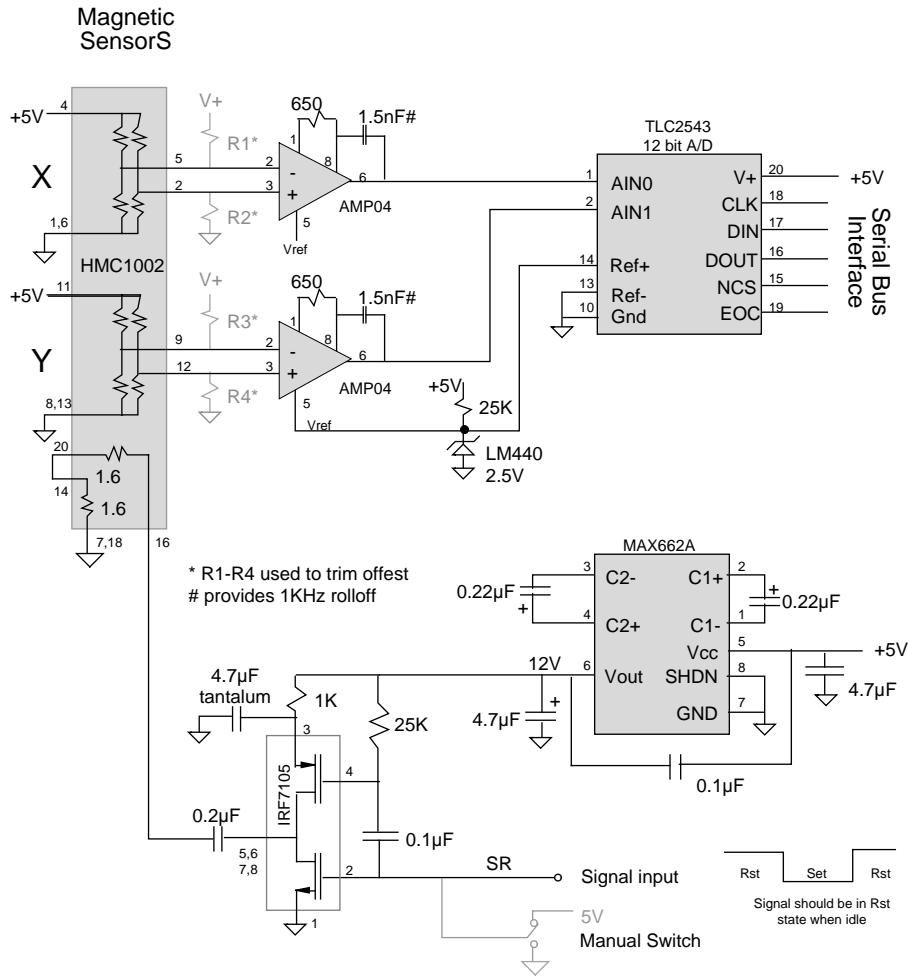
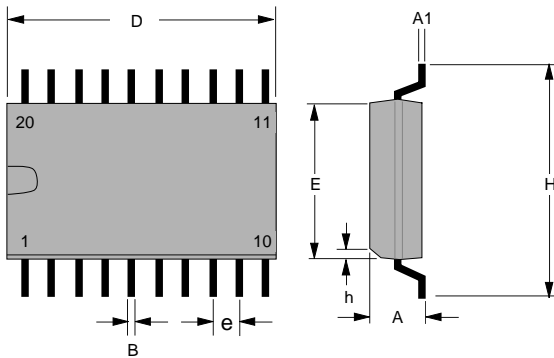

Figure 18—Two-Axis Sensor With Set/Reset Circuit and Digital Interface

HMC10XX FAMILY

PACKAGE OUTLINES

HMC1002—Package Outline



Symbol	Millimeters		Inches	
	Min	Max	Min	Max
A	2.489	2.642	.098	.104
A1	0.127	0.279	.005	.011
B	0.457	0.483	.014	.019
D	12.675	12.929	.499	.509
E	7.264	7.417	.286	.292
e	1.270 ref		.050 ref	
H	1.270	10.566	.396	.416
h	0.381	ref	.015	.030

HMC1001—8-Pin SIP and HMC1021Z—8-Pin SIP

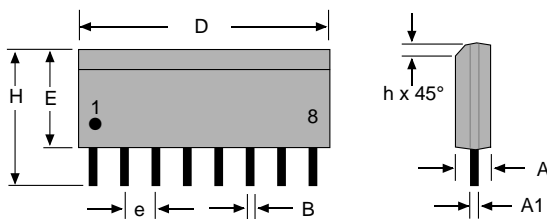

Symbol	Millimeters		Inches	
	Min	Max	Min	Max
A	1.371	1.728	.054	.068
A1	0.101	0.249	.004	.010
B	0.355	0.483	.014	.019
D	9.829	11.253	.387	.443
E	3.810	3.988	.150	.157
e	1.270 ref		.050 ref	
H	5.014	5.314	.197	.209
h	0.381	0.762	.015	.030

HMC1021D—8-Pin Ceramic DIP

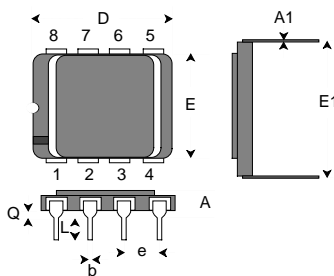

Symbol	Millimeters		Inches	
	Min	Max	Min	Max
A	0.107 ref			
A1			0.009	0.012
b			0.016	0.020
D			—	0.405
E			0.282	0.298
E1			0.290	0.310
e			0.100 ref	
Q			0.015	0.060
L			0.125	0.175

HMC1021S 8-Pin SOIC

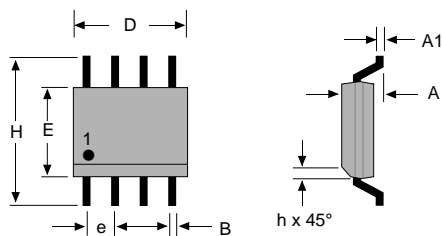

Symbol	Millimeters		Inches	
	Min	Max	Min	Max
A	1.371	1.728	.054	.068
A1	0.101	0.249	.004	.010
B	0.355	0.483	.014	.019
D	4.800	4.979	.189	.196
E	3.810	3.988	.150	.157
e	1.270 ref		.050 ref	
H	5.816	6.198	.229	.244
h	0.381	0.762	.015	.030

HMC1022 16-Pin SOIC

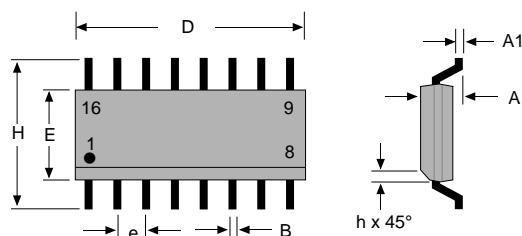

Symbol	Millimeters		Inches	
	Min	Max	Min	Max
A	1.371	1.728	.054	.068
A1	0.101	0.249	.004	.010
B	0.355	0.483	.014	.019
D	9.829	11.253	.387	.443
E	3.810	3.988	.150	.157
e	1.270 ref		.050 ref	
H	5.816	6.198	.229	.244
h	0.381	0.762	.015	.030

DESIGN / PACKAGE OPTIONS

Honeywell offers a range of magnetic microcircuit products. Two different sensor designs and five package configurations are available:

- **HMC1001/1002** series offers a higher sensitivity and lower field resolution.
- **HMC1021/1022** series offers a wider field range, lower set/reset current and has a lower cost for higher volume applications.

Two-axis parts contain two sensors for the x- and y- field measurements. Single-axis variations include a SIP package for mounting through the circuit board to create a 3-axis solution, a SOIC for direct surface mount, and a ceramic DIP for high performance military and high temperature applications.

	HMC1001/02	HMC1021/22	Units
Sensitivity	3.1	1.0	mV/V/G
Resolution	40	85	µgauss
Range	± 2	0.5	gauss
Set/Rst Current	3.0	0.5	Amps
Cost		Lower in high volume	

ORDERING INFORMATION

Part Number	Axis Number	Sensitivity	Package Style
HMC1001	Single	3mV/V/G	8-Pin SIP
HMC1002	Two	3mV/V/G	20-Pin SOIC
HMC1021D	Single	1mV/V/G	8-Pin Ceramic DIP
HMC1021Z	Single	1mV/V/G	8-Pin SIP
HMC1021S	Single	1mV/V/G	8-Pin SOIC
HMC1022	Two	1mV/V/G	16-Pin SOIC

Solid State Electronics Center • 12001 State Highway 55, Plymouth, MN 55441 • (800) 238-1502 • www.magneticsensors.com

Additional Product Details:
Customer Service Representative
(612) 954-2888 fax: (612) 954-2257
E-Mail: clr@mn14.ssec.honeywell.com

Honeywell reserves the right to make changes to any products or technology herein to improve reliability, function or design. Honeywell does not assume any liability arising out of the application or use of any product or circuit described herein; neither does it convey any license under its patent rights nor the rights of others.

Honeywell