

TECHNICAL DATA
DATA SHEET 4110, REV. A

ZENER 5W VOLTAGE REGULATOR

PACKAGE STYLE: Zener 5W/Zener 5W Melf (Suffix "US" denotes melf/surface mount packaging)

CONFIGURATION: Zener 5W Voltage Regulator

-All ratings are @ $T_c = 25\text{ }^\circ\text{C}$ unless otherwise specified.

-Operating $-55\text{ }^\circ\text{C}$ to $+175\text{ }^\circ\text{C}$ and storage $-65\text{ }^\circ\text{C}$ to $+175\text{ }^\circ\text{C}$

MAXIMUM RATINGS / ELECTRICAL CHARACTERISTICS	SYMBOL	VALUE	UNITS
MIN ZENER VOLTAGE	Min V_Z	15.2	Vdc
MAX ZENER VOLTAGE	Max V_Z	16.8	Vdc
TEST CURRENT	I_Z	75	mAmps dc
MAXIMUM IMPEDENCE	Max Z_Z	3.5	ohm
REVERSE VOLTAGE	V_R	12.2	Vdc
MAXIMUM REVERSE CURRENT	Max I_{R1}	5	uAmps dc
MAXIMUM KNEE IMPEDENCE	Max Z_K	155	ohm
MAXIMUM VOLTAGE REGULATION	Max $V_Z(\text{reg})$	1.1	Vdc
MAXIMUM TEMPERATURE COEFFICIENT	αV_Z	0.08	%/ $^\circ\text{C}$
POWER DISSIPATION	POWER	5	Watts

MECHANICAL DIMENSIONS, Zener 5W Package: In Inches / mm

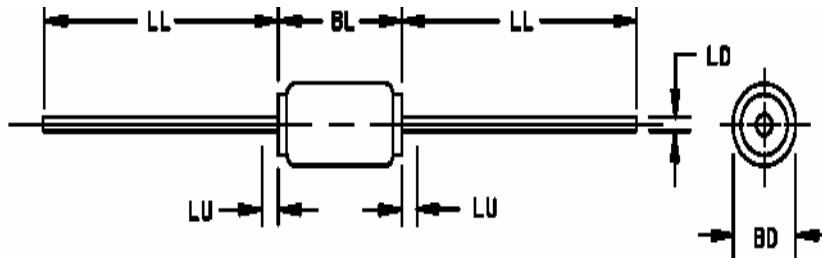

Ltr	Dimensions				Notes
	Inches		Millimeters		
	Min	Max			
BL	.130	.300	3.30	4.95	
BD	.090	.145	2.92	4.70	
LL	1.00	1.300	25.40	33.02	
LU		.050		1.27	4
LD	.037	.043	0.94	1.89	3

SENSITRON
SEMICONDUCTOR

1N4963/1N4963US
JAN1N4963/JAN1N4963US
JANTX1N4963/JANTX1N4963US
JANTXV1N4963/JANTXV1N4963US

TECHNICAL DATA
DATA SHEET 4110, REV. A

MECHANICAL DIMENSIONS, Zener 5W Melf Package: In Inches / mm

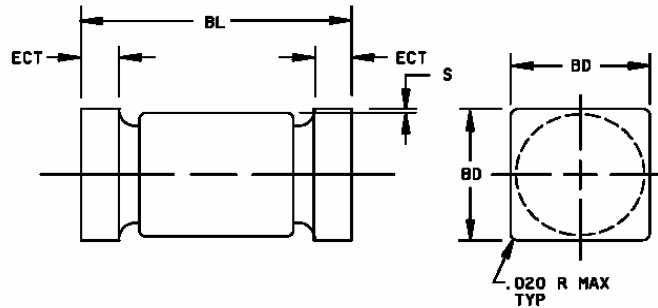

Ltr	Dimensions			
	Inches		Millimeters	
	Min	Max	Min	Max
BL	.200	.225	5.08	5.72
ECT	.019	.028	0.48	0.71
S	.003	- - -	0.08	- - -
BD	.137	.148	3.48	3.76

DISCLAIMER:

- 1- The information given herein, including the specifications and dimensions, is subject to change without prior notice to improve product characteristics. Before ordering, purchasers are advised to contact the Sensitron Semiconductor sales department for the latest version of the datasheet(s).
- 2- In cases where extremely high reliability is required (such as use in nuclear power control, aerospace and aviation, traffic equipment, medical equipment, and safety equipment), safety should be ensured by using semiconductor devices that feature assured safety or by means of users' fail-safe precautions or other arrangement.
- 3- In no event shall Sensitron Semiconductor be liable for any damages that may result from an accident or any other cause during operation of the user's units according to the datasheet(s). Sensitron Semiconductor assumes no responsibility for any intellectual property claims or any other problems that may result from applications of information, products or circuits described in the datasheets.
- 4- In no event shall Sensitron Semiconductor be liable for any failure in a semiconductor device or any secondary damage resulting from use at a value exceeding the absolute maximum rating.
- 5- No license is granted by the datasheet(s) under any patents or other rights of any third party or Sensitron Semiconductor.
- 6- The datasheet(s) may not be reproduced or duplicated, in any form, in whole or part, without the expressed written permission of Sensitron Semiconductor.
- 7- The products (technologies) described in the datasheet(s) are not to be provided to any party whose purpose in their application will hinder maintenance of international peace and safety nor are they to be applied to that purpose by their direct purchasers or any third party. When exporting these products (technologies), the necessary procedures are to be taken in accordance with related laws and regulations.