

# Data Sheet

**aIVR1004 – 10 sec**

**aIVR2104 – 21 sec**

**aIVR4208 – 42 sec**

## **APLUS INTEGRATED CIRCUITS INC.**

---

**Address:**

3 F-10, No. 32, Sec. 1, Chenggung Rd., Taipei,  
Taiwan 115, R.O.C.  
(115)台北市南港區成功路一段 32 號 3 樓之 10.

**TEL:** 886-2-2782-9266

**FAX:** 886-2-2782-9255

**WEBSITE :** <http://www.aplusinc.com.tw>

**Sales E-mail:**

[sales@aplusinc.com.tw](mailto:sales@aplusinc.com.tw)

**Technology E-mail:**

[service@aplusinc.com.tw](mailto:service@aplusinc.com.tw)

## FEATURES

- Standard CMOS process.
- Embedded EPROM.
- Embedded 8-bit MCU.
- 10, 21 and 42sec voice duration at 6 KHz sampling with 4-bit ADPCM compression.
- Combination of voice building blocks to extend playback duration.
- Table entries are available for voice block combinations.
- User selectable PCM or ADPCM data compress.
- Voice Group Trigger Options: Edge / Level; Hold / Un-hold; Retrigger / Non-retrigger.
- Programmable I/Os, Timer Interrupt and Watch Dog Timer.
- Built-in oscillator with fixed  $R_{osc}$ , software control sampling frequency
- 2.2V – 3.6V single power supply and < 5uA low stand-by current.
- PWM Vout1 and Vout2 drive speaker directly.
- D/A COUT with ramp-up ramp-down option to drive speaker through an external BJT.

## DESCRIPTION

Aplus' aIVR is a 8-bit CPU based Voice chip series. It is fabricated with Standard CMOS process with embedded voice storage memory. It can store from 10 to 42sec voice message with 4-bit ADPCM compression at 6KHz sampling rate. 8-bit PCM is also available as user selectable option to improve sound quality. Depending on IC body, there are up to twelve programmable I/O pins. Key trigger and Parallel CPU trigger mode can be configured according to different application requirement. User selectable triggering and output signal options provide maximum flexibility to various applications. Built-in resistor controlled oscillator, 8-bit current mode D/A output and PWM direct speaker driving output minimize the number of external components.

<b>Part Number</b>	<b>Duration</b>	<b>Programmable IO</b>
aIVR1004	10 sec	4
aIVR2104	21 sec	4
aIVR4208	42 sec	8

**PIN CONFIGURATIONS**

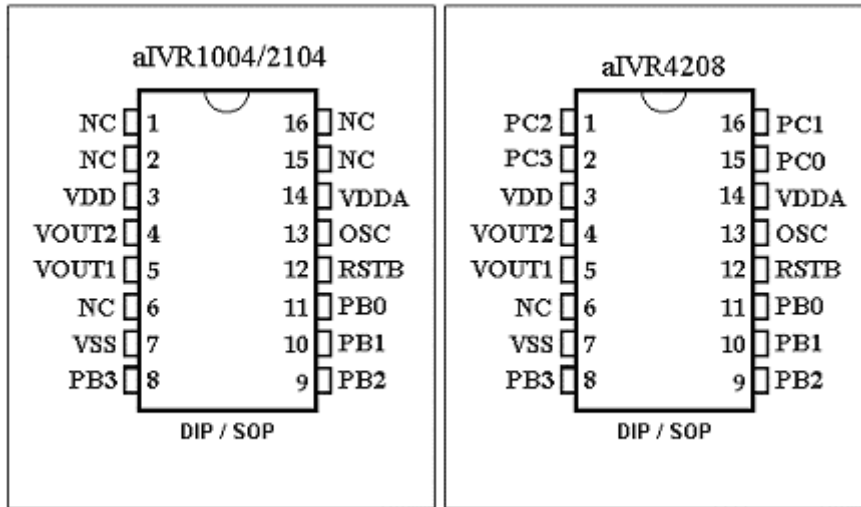

**PIN DESCRIPTIONS**

Pin Names	Description
VOUT1	PWM output to drive speaker directly
VOUT2_COUT	PWM output or COUT DAC output select by programmable option
VSS	Power Ground
OSC	Oscillator input
VDDA	Positive Power Supply
VDD	Positive Power Supply
PBn	Programmable I/O pins (n: 0 to 3 for all aIVR chips)
PCn	Programmable I/O pins (n: 0 to 3 for aIVR4208 only)
RSTB	Reset pin, Low active

Note:

PBn and PCn are software programmable I/O pins that can be set to different configurations such as pure input, input with pull-up, input with pull-down and output. The programmable I/O pins set up will take effect immediately after chip RESET is applied.

**BLOCK DIAGRAM**

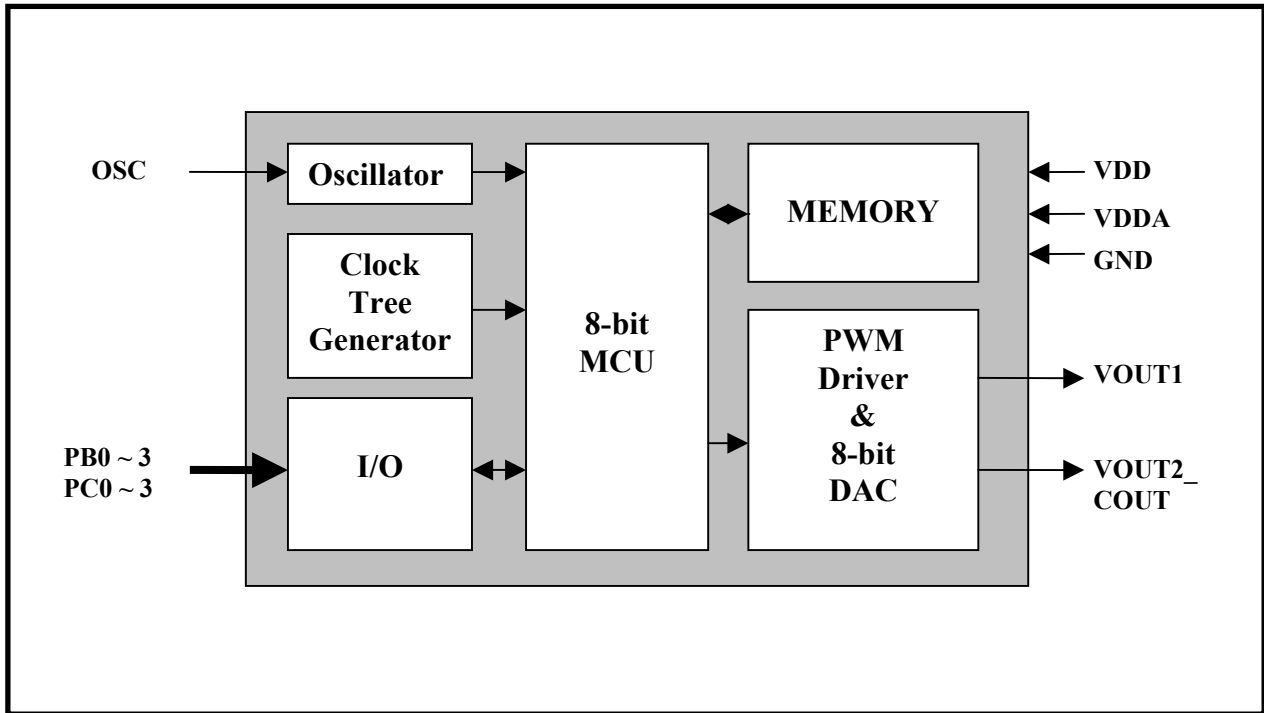

**ABSOLUTE MAXIMUM RATINGS**

Symbol	Rating	Unit
$V_{DD} - V_{SS}$	-0.5 ~ +4.0	V
$V_{IN}$	$V_{SS} - 0.3 < V_{IN} < V_{DD} + 0.3$	V
$V_{OUT}$	$V_{SS} < V_{OUT} < V_{DD}$	V
T (Operating):	-40 ~ +85	°C
T (Junction)	-40 ~ +125	°C
T (Storage)	-55 ~ +125	°C

## DC CHARACTERISTICS ( $T_A = 0$ to $70^\circ\text{C}$ , $V_{DD} = 3.0\text{V}$ , $V_{SS} = 0\text{V}$ )

Symbol	Parameter	Min.	Typ.	Max.	Unit	Conditions
$V_{DD}$	Operating Voltage	2.2	3.0	3.6	V	
$I_{SB}$	Standby current	—	1	5	$\mu\text{A}$	I/O properly terminated
$I_{OP}$	Operating current	—	—	15	mA	I/O properly terminated
$V_{IH}$	"H" Input Voltage	2.5	3.0	3.5	V	$V_{DD}=3.0\text{V}$
$V_{IL}$	"L" Input Voltage	-0.3	0	0.5	V	$V_{DD}=3.0\text{V}$
$I_{VOUTL}$	$V_{OUT}$ low O/P Current	—	130	—	mA	$V_{out}=1.0\text{V}$
$I_{VOUTH}$	$V_{OUT}$ high O/P Current	—	-130	—	mA	$V_{out}=2.0\text{V}$
$I_{CO}$	$C_{OUT}$ O/P Current	—	-2	—	mA	Data = 80h
$I_{OH}$	O/P High Current	—	-8	—	mA	$V_{OH}=2.5\text{V}$
$I_{OL}$	O/P Low Current	—	8	—	mA	$V_{OL}=0.3\text{V}$
$R_{NVOUT}$	VOUT pull-down resistance	—	100K	—	$\Omega$	VOUT pin set to internal pull-down
$R_{NPIO}$	Programmable IO pin pull-down resistance	—	1M	—	$\Omega$	PBx, PCx, PDx set to internal pull-down
$R_{UPIO}$	Programmable IO pin pull-up resistance	3.3K	4.7K	—	$\Omega$	PBx, PCx, PDx set to internal pull-up
$\Delta F_s/F_s$	Frequency stability	-3	—	+3	%	$V_{DD} = 3\text{V} \pm 0.4\text{V}$
$\Delta F_c/F_c$	Chip to chip Frequency Variation	-5	—	+5	%	Also apply to lot to lot variation

**TYPICAL APPLICATIONS**

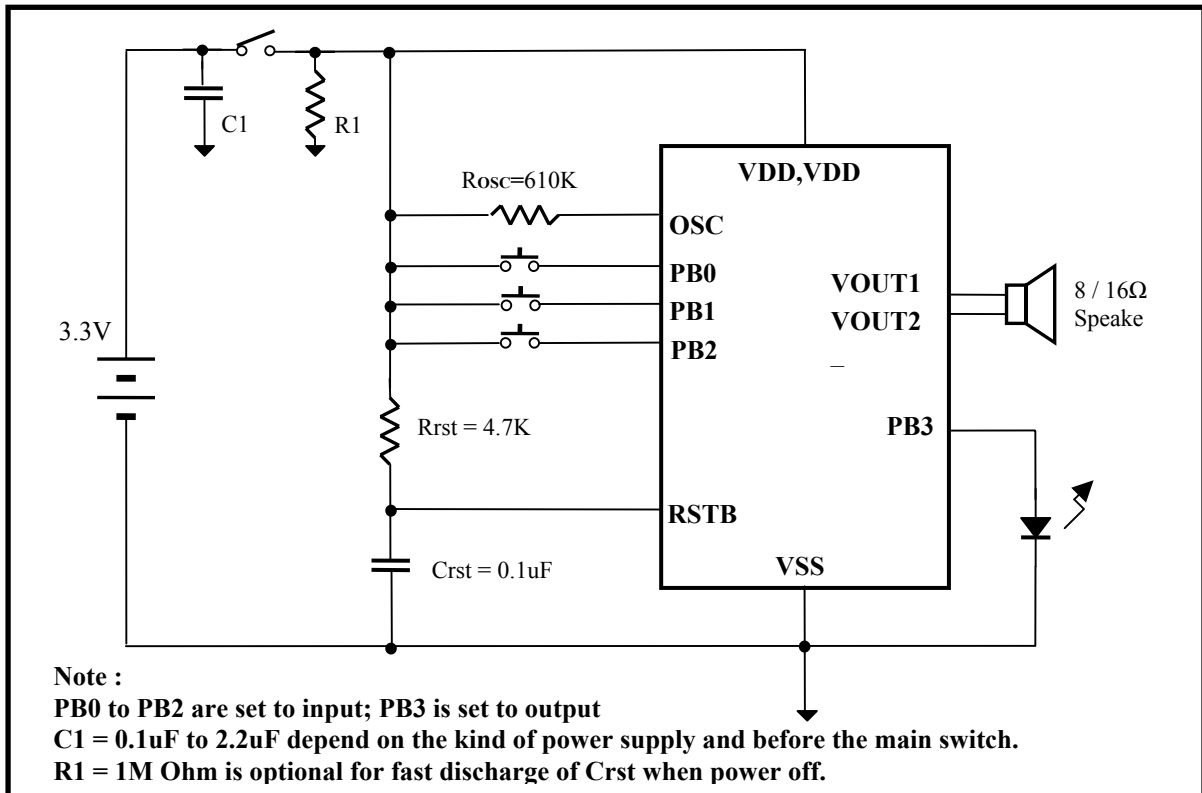

Using 3.3V Battery

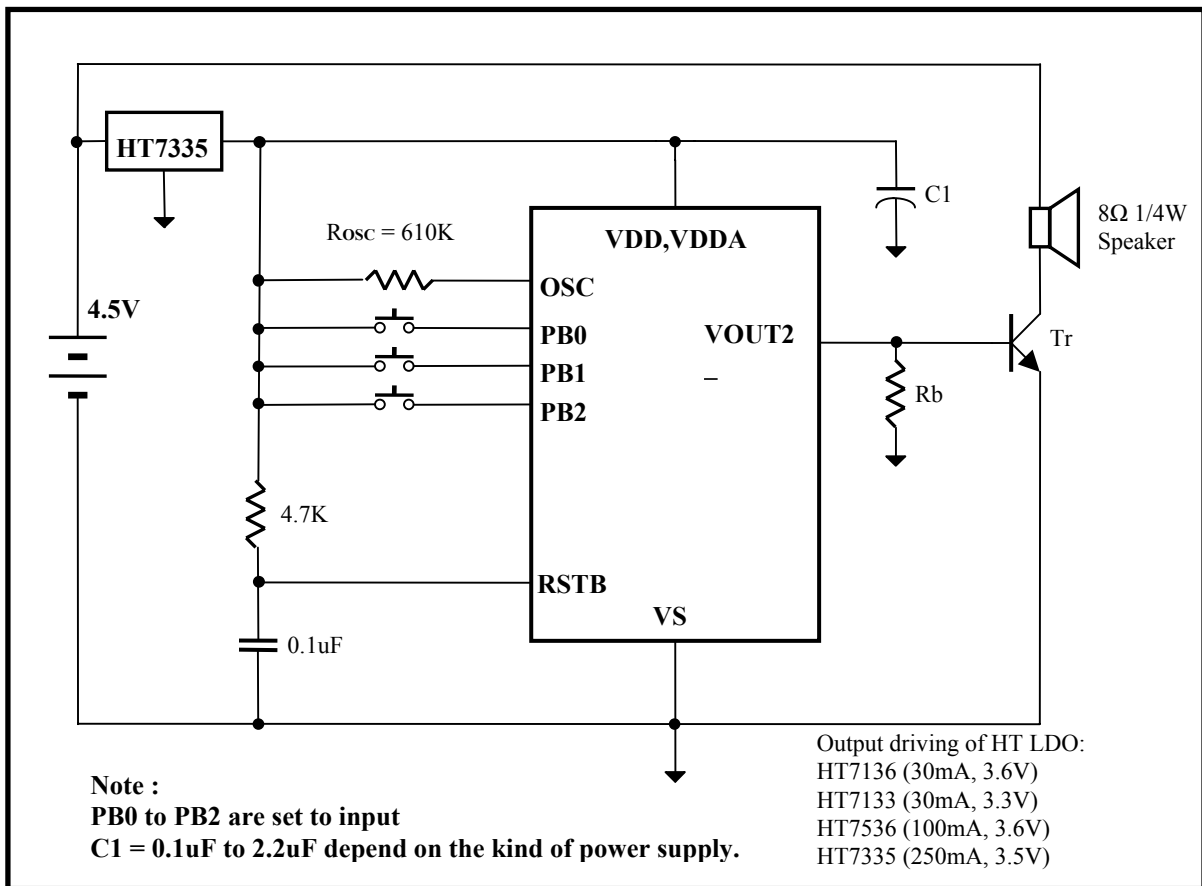

Using 4.5V Battery

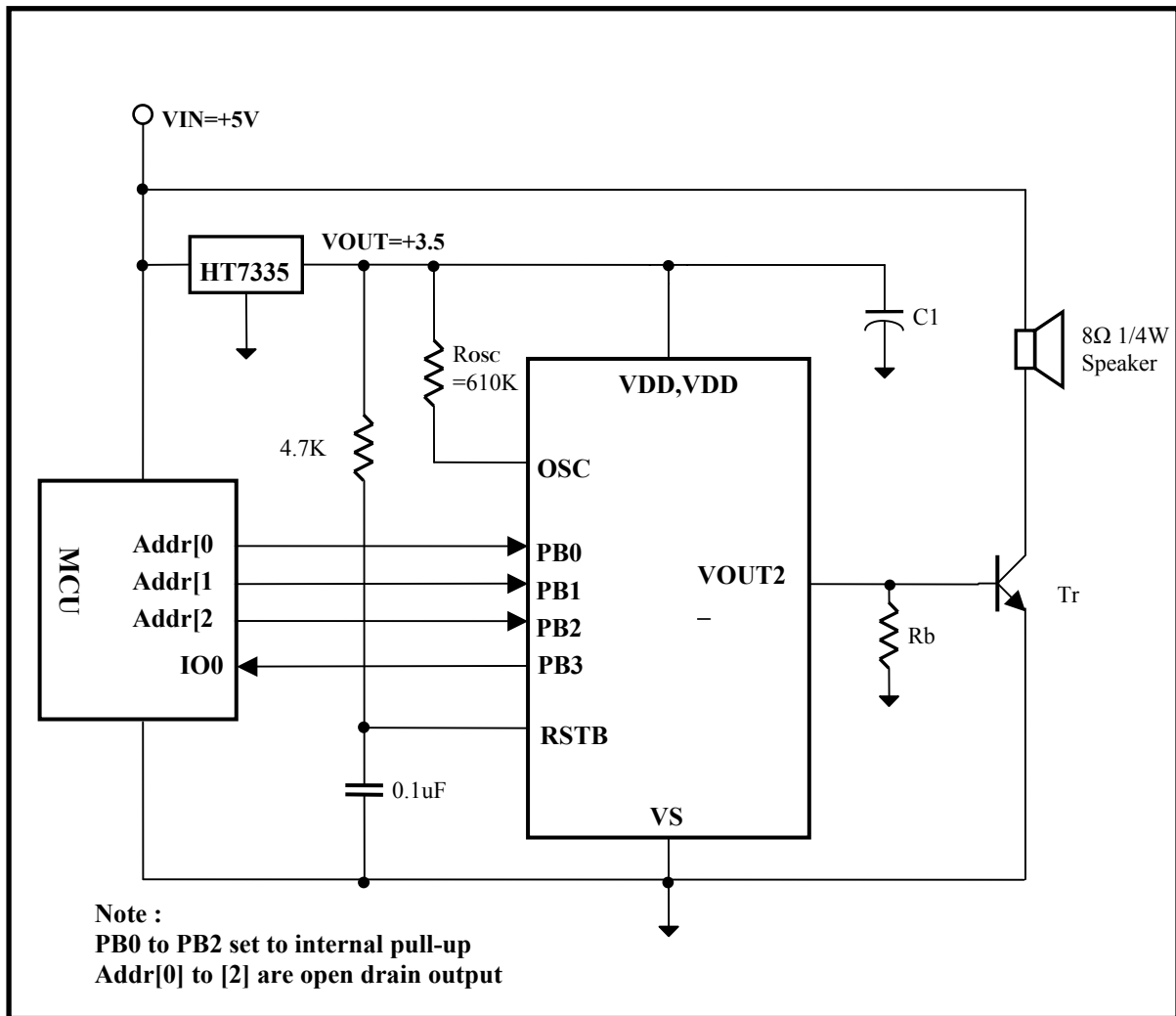

5V CPU Control with COUT

Note:

1. C1 is capacitor from 0.1uF to 2.2uF depends on the kind of Vdd source and sound loudness. E.g. If COUT is used, C1 can be 0.1uF. However, if PWM direct drive speaker is used, C1 should be at least 2.2uF
2. Rb is base resistor from 120 Ohm to 390 Ohm depends on Vdd value and transistor gain.
3. Tr is an NPN transistor with beta larger than 150, e.g. 8050D.
4. Rosc = 610K Ohm with Vdd=3.0V and support sampling rate up to 14KHz
5. For sampling rate higher than 14KHz, smaller value of Rosc should be used.

**Bonding Diagrams**

