

**4-Mbit (512 K × 8/256 K × 16) nvSRAM**

**Features**

- 20 ns, 25 ns, and 45 ns access times
- Internally organized as 512 K × 8 (CY14B104LA) or 256 K × 16 (CY14B104NA)
- Hands off automatic STORE on power-down with only a small capacitor
- STORE to QuantumTrap non-volatile elements initiated by software, device pin, or AutoStore on power-down
- RECALL to SRAM initiated by software or power-up
- Infinite read, write, and recall cycles
- 1 million STORE cycles to QuantumTrap
- 20 year data retention
- Single 3 V +20%, -10% operation
- Industrial temperature

■ Packages

- 44-/54-pin thin small outline package (TSOP) Type II
- 48-ball fine-pitch ball grid array (FBGA)

■ Pb-free and restriction of hazardous substances (RoHS) compliant

**Functional Description**

The Cypress CY14B104LA/CY14B104NA is a fast static RAM (SRAM), with a non-volatile element in each memory cell. The memory is organized as 512 K bytes of 8 bits each or 256 K words of 16-bits each. The embedded non-volatile elements incorporate QuantumTrap technology, producing the world's most reliable non-volatile memory. The SRAM provides infinite read and write cycles, while independent non-volatile data resides in the highly reliable QuantumTrap cell. Data transfers from the SRAM to the non-volatile elements (the STORE operation) takes place automatically at power-down. On power-up, data is restored to the SRAM (the RECALL operation) from the non-volatile memory. Both the STORE and RECALL operations are also available under software control.

**Logic Block Diagram [1, 2, 3]**

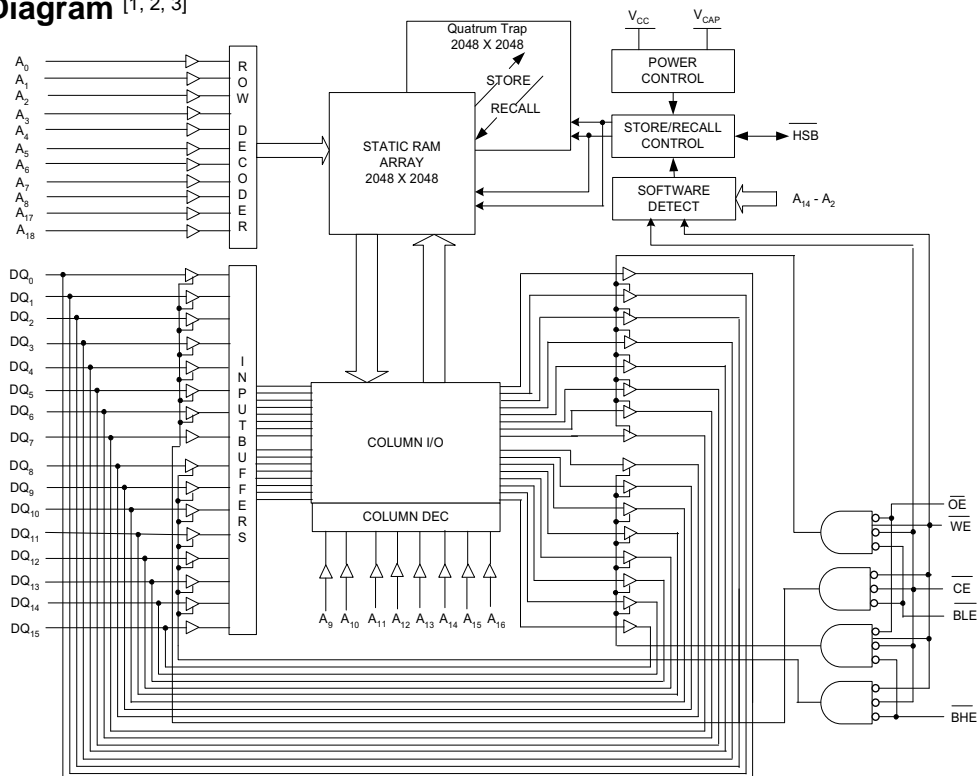

**Notes**

1. Address A<sub>0</sub>-A<sub>18</sub> for × 8 configuration and Address A<sub>0</sub>-A<sub>17</sub> for × 16 configuration.
2. Data DQ<sub>0</sub>-DQ<sub>7</sub> for × 8 configuration and Data DQ<sub>0</sub>-DQ<sub>15</sub> for × 16 configuration.
3. BHE and BLE are applicable for × 16 configuration only.

**Contents**

<b>Pinouts</b> .....	<b>3</b>	<b>AC Switching Characteristics</b> .....	<b>11</b>
<b>Pin Definitions</b> .....	<b>4</b>	<b>Switching Waveforms</b> .....	<b>11</b>
<b>Device Operation</b> .....	<b>5</b>	<b>AutoStore/Power-Up RECALL</b> .....	<b>14</b>
<b>SRAM Read</b> .....	<b>5</b>	<b>Switching Waveforms</b> .....	<b>14</b>
<b>SRAM Write</b> .....	<b>5</b>	<b>Software Controlled STORE/RECALL Cycle</b> .....	<b>15</b>
<b>AutoStore Operation</b> .....	<b>5</b>	<b>Switching Waveforms</b> .....	<b>15</b>
<b>Hardware STORE Operation</b> .....	<b>5</b>	<b>Hardware STORE Cycle</b> .....	<b>16</b>
<b>Hardware RECALL (Power-Up)</b> .....	<b>6</b>	<b>Switching Waveforms</b> .....	<b>16</b>
<b>Software STORE</b> .....	<b>6</b>	<b>Truth Table For SRAM Operations</b> .....	<b>17</b>
<b>Software RECALL</b> .....	<b>6</b>	<b>Ordering Information</b> .....	<b>18</b>
<b>Preventing AutoStore</b> .....	<b>7</b>	Ordering Code Definitions .....	<b>19</b>
<b>Data Protection</b> .....	<b>7</b>	<b>Package Diagrams</b> .....	<b>20</b>
<b>Noise Considerations</b> .....	<b>7</b>	<b>Acronyms</b> .....	<b>23</b>
<b>Best Practices</b> .....	<b>8</b>	Document Conventions .....	<b>23</b>
<b>Maximum Ratings</b> .....	<b>9</b>	Units of Measure .....	<b>23</b>
<b>Operating Range</b> .....	<b>9</b>	<b>Document History Page</b> .....	<b>24</b>
<b>DC Electrical Characteristics</b> .....	<b>9</b>	<b>Sales, Solutions, and Legal Information</b> .....	<b>25</b>
<b>Data Retention and Endurance</b> .....	<b>10</b>	Worldwide Sales and Design Support .....	<b>25</b>
<b>Capacitance</b> .....	<b>10</b>	Products .....	<b>25</b>
<b>Thermal Resistance</b> .....	<b>10</b>	PSoC Solutions .....	<b>25</b>
<b>AC Test Loads</b> .....	<b>10</b>		
<b>AC Test Conditions</b> .....	<b>10</b>		

Pinouts

Figure 1. Pin Diagram – 48-ball FBGA

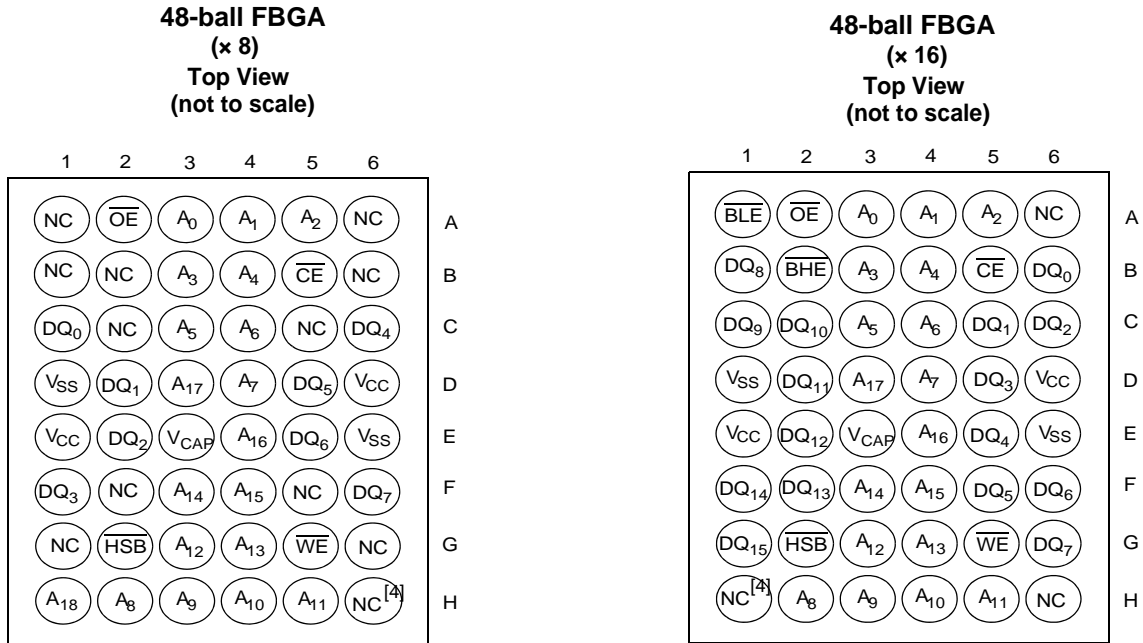
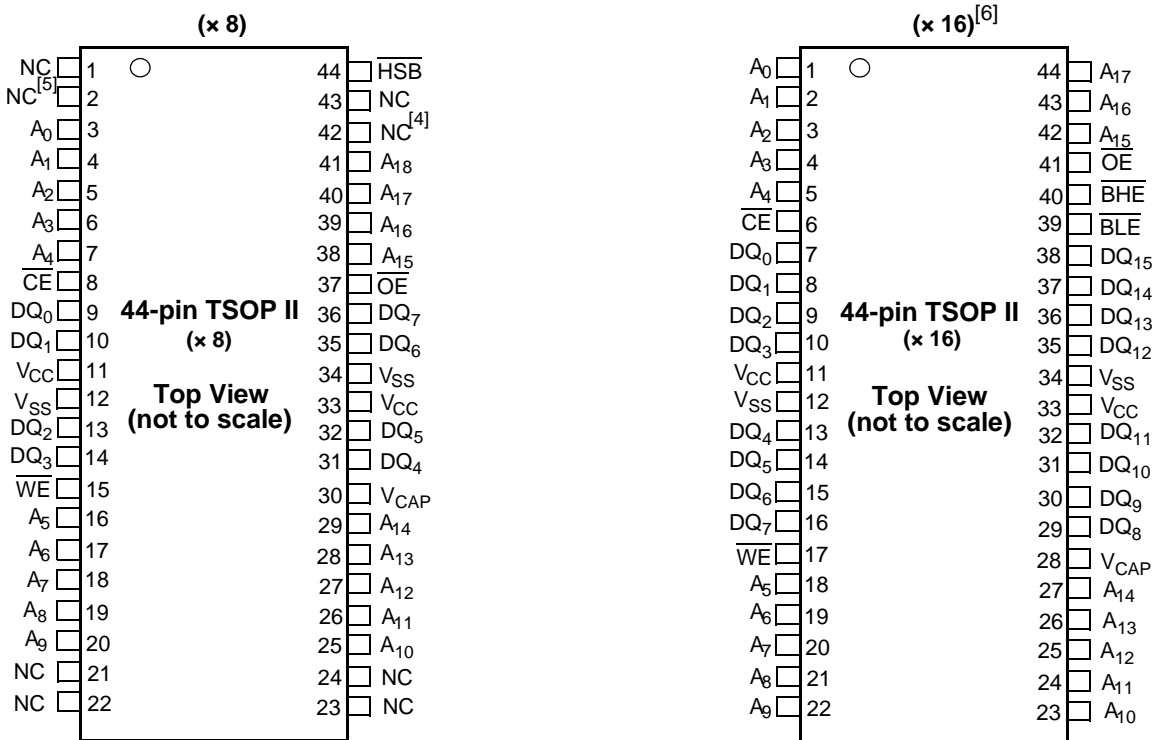

Figure 2. Pin Diagram – 44-pin TSOP II



Notes

4. Address expansion for 8-Mbit. NC pin not connected to die.
5. Address expansion for 16-Mbit. NC pin not connected to die.
6. HSB pin is not available in 44-pin TSOP II (x 16) package.

Pinouts (continued)

Figure 3. Pin Diagram – 54-pin TSOP II (x 16)

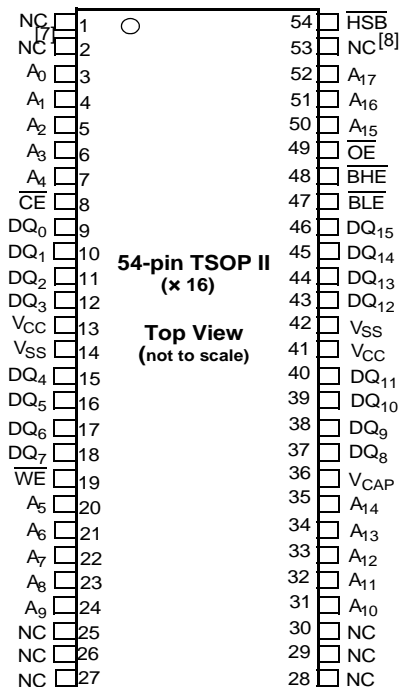

Pin Definitions

Pin Name	I/O Type	Description
A <sub>0</sub> –A <sub>18</sub>	Input	<b>Address inputs.</b> Used to select one of the 524,288 bytes of the nvSRAM for x 8 Configuration.
A <sub>0</sub> –A <sub>17</sub>		<b>Address inputs.</b> Used to Select one of the 262,144 words of the nvSRAM for x 16 Configuration.
DQ <sub>0</sub> –DQ <sub>7</sub>	Input/Output	<b>Bidirectional data I/O lines for x 8 configuration.</b> Used as input or output lines depending on operation.
DQ <sub>0</sub> –DQ <sub>15</sub>		<b>Bidirectional data I/O lines for x 16 configuration.</b> Used as input or output lines depending on operation.
WE	Input	<b>Write Enable input, Active LOW.</b> When selected LOW, data on the I/O pins is written to the specific address location.
CE	Input	<b>Chip Enable input, Active LOW.</b> When LOW, selects the chip. When HIGH, deselects the chip.
OE	Input	<b>Output Enable, Active LOW.</b> The active LOW OE input enables the data output buffers during read cycles. I/O pins are tristated on deasserting OE HIGH.
BHE	Input	<b>Byte High Enable, Active LOW.</b> Controls DQ <sub>15</sub> –DQ <sub>8</sub> .
BLE	Input	<b>Byte Low Enable, Active LOW.</b> Controls DQ <sub>7</sub> –DQ <sub>0</sub> .
V <sub>SS</sub>	Ground	<b>Ground for the device.</b> Must be connected to the ground of the system.
V <sub>CC</sub>	Power supply	<b>Power supply inputs to the device.</b>
HSB <sup>[9]</sup>	Input/Output	<b>Hardware STORE Busy (HSB).</b> When LOW this output indicates that a Hardware STORE is in progress. When pulled LOW external to the chip it initiates a non-volatile STORE operation. After each Hardware and Software STORE operation, HSB is driven HIGH for a short time (t <sub>HHHD</sub> ) with standard output high current, and then a weak internal pull-up resistor keeps this pin HIGH (external pull-up resistor connection optional).
V <sub>CAP</sub>	Power supply	<b>AutoStore Capacitor.</b> Supplies power to the nvSRAM during power loss to store data from SRAM to non-volatile elements.
NC	No connect	<b>No Connect.</b> This pin is not connected to the die.

Notes

- 7. Address expansion for 16-Mbit. NC pin not connected to die.
- 8. Address expansion for 8-Mbit. NC pin not connected to die.
- 9. HSB pin is not available in 44-pin TSOP II (x 16) package.

## Device Operation

The CY14B104LA/CY14B104NA nvSRAM is made up of two functional components paired in the same physical cell. They are a SRAM memory cell and a non-volatile QuantumTrap cell. The SRAM memory cell operates as a standard fast static RAM. Data in the SRAM is transferred to the non-volatile cell (the STORE operation), or from the non-volatile cell to the SRAM (the RECALL operation). Using this unique architecture, all cells are stored and recalled in parallel. During the STORE and RECALL operations, SRAM read and write operations are inhibited. The CY14B104LA/CY14B104NA supports infinite reads and writes similar to a typical SRAM. In addition, it provides infinite RECALL operations from the non-volatile cells and up to 1 million STORE operations. Refer to the [Truth Table For SRAM Operations on page 17](#) for a complete description of read and write modes.

## SRAM Read

The CY14B104LA/CY14B104NA performs a read cycle when  $\overline{CE}$  and  $\overline{OE}$  are LOW and  $\overline{WE}$  and HSB are HIGH. The address specified on pins  $A_{0-18}$  or  $A_{0-17}$  determines which of the 524,288 data bytes or 262,144 words of 16 bits each are accessed. Byte enables (BHE, BLE) determine which bytes are enabled to the output, in the case of 16-bit words. When the read is initiated by an address transition, the outputs are valid after a delay of  $t_{AA}$  (read cycle 1). If the read is initiated by  $\overline{CE}$  or  $\overline{OE}$ , the outputs are valid at  $t_{ACE}$  or  $t_{DOE}$ , whichever is later (read cycle 2). The data output repeatedly responds to address changes within the  $t_{AA}$  access time without the need for transitions on any control input pins. This remains valid until another address change or until  $\overline{CE}$  or  $\overline{OE}$  is brought HIGH, or  $\overline{WE}$  or HSB is brought LOW.

## SRAM Write

A write cycle is performed when  $\overline{CE}$  and  $\overline{WE}$  are LOW and HSB is HIGH. The address inputs must be stable before entering the write cycle and must remain stable until  $\overline{CE}$  or  $\overline{WE}$  goes HIGH at the end of the cycle. The data on the common I/O pins  $DQ_{0-15}$  are written into the memory if the data is valid ( $t_{SD}$  time) before the end of a  $\overline{WE}$  controlled write or before the end of an  $\overline{CE}$  controlled write. The Byte Enable inputs (BHE, BLE) determine which bytes are written, in the case of 16-bit words. It is recommended that  $\overline{OE}$  be kept HIGH during the entire write cycle to avoid data bus contention on common I/O lines. If  $\overline{OE}$  is left LOW, internal circuitry turns off the output buffers  $t_{HZWE}$  after  $\overline{WE}$  goes LOW.

## AutoStore Operation

The CY14B104LA/CY14B104NA stores data to the nvSRAM using one of the following three storage operations: Hardware STORE activated by the HSB; Software STORE activated by an address sequence; AutoStore on device power-down. The AutoStore operation is a unique feature of QuantumTrap technology and is enabled by default on the CY14B104LA/CY14B104NA.

During a normal operation, the device draws current from  $V_{CC}$  to charge a capacitor connected to the  $V_{CAP}$  pin. This stored charge is used by the chip to perform a single STORE operation. If the voltage on the  $V_{CC}$  pin drops below  $V_{SWITCH}$ , the part

automatically disconnects the  $V_{CAP}$  pin from  $V_{CC}$ . A STORE operation is initiated with power provided by the  $V_{CAP}$  capacitor.

**Note** If the capacitor is not connected to  $V_{CAP}$  pin, AutoStore must be disabled using the soft sequence specified in [Preventing AutoStore on page 7](#). In case AutoStore is enabled without a capacitor on  $V_{CAP}$  pin, the device attempts an AutoStore operation without sufficient charge to complete the Store. This corrupts the data stored in nvSRAM.

Figure 4 shows the proper connection of the storage capacitor ( $V_{CAP}$ ) for automatic store operation. Refer to [DC Electrical Characteristics on page 9](#) for the size of  $V_{CAP}$ . The voltage on the  $V_{CAP}$  pin is driven to  $V_{CC}$  by a regulator on the chip. A pull-up should be placed on  $\overline{WE}$  to hold it inactive during power-up. This pull-up is effective only if the  $\overline{WE}$  signal is tristate during power-up. Many MPUs tristate their controls on power-up. This should be verified when using the pull-up. When the nvSRAM comes out of power-on-RECALL, the MPU must be active or the  $\overline{WE}$  held inactive until the MPU comes out of reset.

To reduce unnecessary non-volatile stores, AutoStore and hardware STORE operations are ignored unless at least one write operation has taken place since the most recent STORE or RECALL cycle. Software initiated STORE cycles are performed regardless of whether a write operation has taken place. The HSB signal is monitored by the system to detect if an AutoStore cycle is in progress.

Figure 4. AutoStore Mode

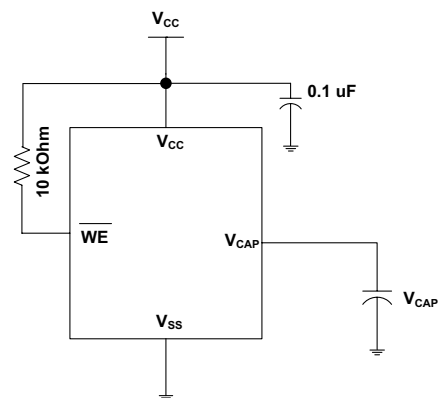

## Hardware STORE Operation

The CY14B104LA/CY14B104NA provides the  $\overline{HSB}^{[10]}$  pin to control and acknowledge the STORE operations. The  $\overline{HSB}$  pin is used to request a hardware STORE cycle. When the  $\overline{HSB}$  pin is driven LOW, the CY14B104LA/CY14B104NA conditionally initiates a STORE operation after  $t_{DELAY}$ . An actual STORE cycle only begins if a write to the SRAM has taken place since the last STORE or RECALL cycle. The  $\overline{HSB}$  pin also acts as an open drain driver (internal 100 k $\Omega$  weak pull-up resistor) that is internally driven LOW to indicate a busy condition when the STORE (initiated by any means) is in progress.

**Note** After each Hardware and Software STORE operation  $\overline{HSB}$  is driven HIGH for a short time ( $t_{HHHD}$ ) with standard output high current and then remains HIGH by internal 100 k $\Omega$  pull-up resistor.

### Note

10. HSB pin is not available in 44-pin TSOP II (x 16) package.

SRAM write operations that are in progress when  $\overline{\text{HSB}}$  is driven LOW by any means are given time ( $t_{\text{DELAY}}$ ) to complete before the STORE operation is initiated. However, any SRAM write cycles requested after  $\overline{\text{HSB}}$  goes LOW are inhibited until  $\overline{\text{HSB}}$  returns HIGH. In case the write latch is not set,  $\overline{\text{HSB}}$  is not driven LOW by the CY14B104LA/CY14B104NA. But any SRAM read and write cycles are inhibited until  $\overline{\text{HSB}}$  is returned HIGH by MPU or other external source.

During any STORE operation, regardless of how it is initiated, the CY14B104LA/CY14B104NA continues to drive the  $\overline{\text{HSB}}$  pin LOW, releasing it only when the STORE is complete. Upon completion of the STORE operation, the nvSRAM memory access is inhibited for  $t_{\text{LZHSB}}$  time after  $\overline{\text{HSB}}$  pin returns HIGH. Leave the  $\overline{\text{HSB}}$  unconnected if it is not used.

## Hardware RECALL (Power-Up)

During power-up or after any low power condition ( $V_{\text{CC}} < V_{\text{SWITCH}}$ ), an internal RECALL request is latched. When  $V_{\text{CC}}$  again exceeds the  $V_{\text{SWITCH}}$  on power up, a RECALL cycle is automatically initiated and takes  $t_{\text{HRECALL}}$  to complete. During this time, the  $\overline{\text{HSB}}$  pin is driven LOW by the  $\overline{\text{HSB}}$  driver and all reads and writes to nvSRAM are inhibited.

## Software STORE

Data is transferred from the SRAM to the non-volatile memory by a software address sequence. The CY14B104LA/CY14B104NA software STORE cycle is initiated by executing sequential  $\overline{\text{CE}}$  or  $\overline{\text{OE}}$  controlled read cycles from six specific address locations in exact order. During the STORE cycle an erase of the previous non-volatile data is first performed, followed by a program of the non-volatile elements. After a STORE cycle is initiated, further input and output are disabled until the cycle is completed.

Because a sequence of reads from specific addresses is used for STORE initiation, it is important that no other read or write accesses intervene in the sequence, or the sequence is aborted and no STORE or RECALL takes place.

To initiate the software STORE cycle, the following read sequence must be performed.

1. Read address 0x4E38 Valid READ
2. Read address 0xB1C7 Valid READ
3. Read address 0x83E0 Valid READ
4. Read address 0x7C1F Valid READ
5. Read address 0x703F Valid READ
6. Read address 0x8FC0 Initiate STORE cycle

The software sequence may be clocked with  $\overline{\text{CE}}$  controlled reads or  $\overline{\text{OE}}$  controlled reads, with  $\overline{\text{WE}}$  kept HIGH for all the six READ sequences. After the sixth address in the sequence is entered, the STORE cycle commences and the chip is disabled.  $\overline{\text{HSB}}$  is driven LOW. After the  $t_{\text{STORE}}$  cycle time is fulfilled, the SRAM is activated again for the read and write operation.

## Software RECALL

Data is transferred from the non-volatile memory to the SRAM by a software address sequence. A software RECALL cycle is initiated with a sequence of read operations in a manner similar to the software STORE initiation. To initiate the RECALL cycle, perform the following sequence of  $\overline{\text{CE}}$  or  $\overline{\text{OE}}$  controlled read operations must be performed.

1. Read address 0x4E38 Valid READ
2. Read address 0xB1C7 Valid READ
3. Read address 0x83E0 Valid READ
4. Read address 0x7C1F Valid READ
5. Read address 0x703F Valid READ
6. Read address 0x4C63 Initiate RECALL cycle

Internally, RECALL is a two step procedure. First, the SRAM data is cleared; then, the non-volatile information is transferred into the SRAM cells. After the  $t_{\text{RECALL}}$  cycle time, the SRAM is again ready for read and write operations. The RECALL operation does not alter the data in the non-volatile elements.

**Table 1. Mode Selection**

$\overline{\text{CE}}$	$\overline{\text{WE}}$	$\overline{\text{OE}}$	$\overline{\text{BHE}}, \overline{\text{BLE}}^{[11]}$	$\text{A}_{15}\text{-A}_0^{[12]}$	Mode	I/O	Power
H	X	X	X	X	Not selected	Output high Z	Standby
L	H	L	L	X	Read SRAM	Output data	Active
L	L	X	L	X	Write SRAM	Input data	Active
L	H	L	X	0x4E38 0xB1C7 0x83E0 0x7C1F 0x703F 0x8B45	Read SRAM Read SRAM Read SRAM Read SRAM Read SRAM AutoStore Disable	Output data Output data Output data Output data Output data Output data	Active <sup>[13]</sup>

### Notes

11.  $\overline{\text{BHE}}$  and  $\overline{\text{BLE}}$  are applicable for  $\times 16$  configuration only.

12. While there are 19 address lines on the CY14B104LA (18 address lines on the CY14B104NA), only 13 address lines ( $\text{A}_{14}\text{-A}_2$ ) are used to control software modes. The remaining address lines are don't care.

13. The six consecutive address locations must be in the order listed.  $\overline{\text{WE}}$  must be HIGH during all six cycles to enable a non-volatile cycle.



**Table 1. Mode Selection** (continued)

$\overline{CE}$	$\overline{WE}$	$\overline{OE}$	$\overline{BHE}, \overline{BLE}^{[11]}$	$A_{15}-A_0^{[12]}$	Mode	I/O	Power
L	H	L	X	0x4E38 0xB1C7 0x83E0 0x7C1F 0x703F 0x4B46	Read SRAM Read SRAM Read SRAM Read SRAM Read SRAM AutoStore Enable	Output data Output data Output data Output data Output data Output data	Active <sup>[14]</sup>
L	H	L	X	0x4E38 0xB1C7 0x83E0 0x7C1F 0x703F 0x8FC0	Read SRAM Read SRAM Read SRAM Read SRAM Read SRAM Non-volatile STORE	Output data Output data Output data Output data Output data Output high Z	Active I <sub>CC2</sub> <sup>[14]</sup>
L	H	L	X	0x4E38 0xB1C7 0x83E0 0x7C1F 0x703F 0x4C63	Read SRAM Read SRAM Read SRAM Read SRAM Read SRAM Non-volatile RECALL	Output data Output data Output data Output data Output data Output high Z	Active <sup>[14]</sup>

## Preventing AutoStore

The AutoStore function is disabled by initiating an AutoStore disable sequence. A sequence of read operations is performed in a manner similar to the software STORE initiation. To initiate the AutoStore disable sequence, the following sequence of  $\overline{CE}$  or  $\overline{OE}$  controlled read operations must be performed:

1. Read address 0x4E38 Valid READ
2. Read address 0xB1C7 Valid READ
3. Read address 0x83E0 Valid READ
4. Read address 0x7C1F Valid READ
5. Read address 0x703F Valid READ
6. Read address 0x8B45 AutoStore Disable

The AutoStore is re-enabled by initiating an AutoStore enable sequence. A sequence of read operations is performed in a manner similar to the software RECALL initiation. To initiate the AutoStore enable sequence, the following sequence of  $\overline{CE}$  or  $\overline{OE}$  controlled read operations must be performed:

1. Read address 0x4E38 Valid READ
2. Read address 0xB1C7 Valid READ
3. Read address 0x83E0 Valid READ
4. Read address 0x7C1F Valid READ
5. Read address 0x703F Valid READ
6. Read address 0x4B46 AutoStore Enable

If the AutoStore function is disabled or re-enabled, a manual STORE operation (hardware or software) must be issued to save

the AutoStore state through subsequent power-down cycles. The part comes from the factory with AutoStore enabled.

## Data Protection

The CY14B104LA/CY14B104NA protects data from corruption during low voltage conditions by inhibiting all externally initiated STORE and write operations. The low voltage condition is detected when  $V_{CC} < V_{SWITCH}$ . If the CY14B104LA/CY14B104NA is in a write mode (both  $\overline{CE}$  and  $\overline{WE}$  are LOW) at power-up, after a RECALL or STORE, the write is inhibited until the SRAM is enabled after  $t_{LZHSB}$  (HSB to output active). This protects against inadvertent writes during power-up or brown out conditions.

## Noise Considerations

Refer to CY application note [AN1064](#).

### Note

14. The six consecutive address locations must be in the order listed.  $\overline{WE}$  must be HIGH during all six cycles to enable a non-volatile cycle.

## Best Practices

nvSRAM products have been used effectively for over 27 years. While ease-of-use is one of the product's main system values, experience gained working with hundreds of applications has resulted in the following suggestions as best practices:

- The non-volatile cells in this nvSRAM product are delivered from Cypress with 0x00 written in all cells. Incoming inspection routines at customer or contract manufacturer's sites sometimes reprogram these values. Final NV patterns are typically repeating patterns of AA, 55, 00, FF, A5, or 5A. End product's firmware should not assume an NV array is in a set programmed state. Routines that check memory content values to determine first time system configuration, cold or warm boot status, and so on should always program a unique NV pattern (that is, complex 4-byte pattern of 46 E6 49 53 hex or more random bytes) as part of the final system manufacturing test to ensure these system routines work consistently.
- power-up boot firmware routines should rewrite the nvSRAM into the desired state (for example, AutoStore enabled). While the nvSRAM is shipped in a preset state, best practice is to again rewrite the nvSRAM into the desired state as a safeguard against events that might flip the bit inadvertently such as program bugs and incoming inspection routines.
- The  $V_{CAP}$  value specified in this datasheet includes a minimum and a maximum value size. Best practice is to meet this requirement and not exceed the maximum  $V_{CAP}$  value because the nvSRAM internal algorithm calculates  $V_{CAP}$  charge and discharge time based on this maximum  $V_{CAP}$  value. Customers that want to use a larger  $V_{CAP}$  value to make sure there is extra store charge and store time should discuss their  $V_{CAP}$  size selection with Cypress to understand any impact on the  $V_{CAP}$  voltage level at the end of a  $t_{RECALL}$  period.



## Maximum Ratings

Exceeding maximum ratings may impair the useful life of the device. These user guidelines are not tested.

Storage temperature ..... -65 °C to +150 °C

Maximum accumulated storage time

At 150 °C ambient temperature ..... 1000 h

At 85 °C ambient temperature ..... 20 Years

Ambient temperature with

power applied ..... -55 °C to +150 °C

Supply voltage on  $V_{CC}$  relative to  $V_{SS}$  ..... -0.5 V to 4.1 V

Voltage applied to outputs

in high Z state ..... -0.5 V to  $V_{CC} + 0.5$  V

Input voltage ..... -0.5 V to  $V_{CC} + 0.5$  V

Transient voltage (< 20 ns) on

any pin to ground potential ..... -2.0 V to  $V_{CC} + 2.0$  V

Package power dissipation

capability ( $T_A = 25$  °C) ..... 1.0 W

Surface mount Pb soldering

temperature (3 Seconds) ..... +260 °C

DC output current (1 output at a time, 1s duration) .... 15 mA

Static discharge voltage

(per MIL-STD-883, Method 3015) ..... > 2001 V

Latch up current ..... > 200 mA

## Operating Range

Range	Ambient Temperature	$V_{CC}$
Industrial	-40 °C to +85 °C	2.7 V to 3.6 V

## DC Electrical Characteristics

Over the [Operating Range](#) ( $V_{CC} = 2.7$  V to 3.6 V)

Parameter	Description	Test Conditions	Min	Typ <sup>[15]</sup>	Max	Unit
$V_{CC}$	Power supply		2.7	3.0	3.6	V
$I_{CC1}$	Average $V_{CC}$ current	$t_{RC} = 20$ ns $t_{RC} = 25$ ns $t_{RC} = 45$ ns Values obtained without output loads ( $I_{OUT} = 0$ mA)	-	-	70 70 52	mA mA mA
$I_{CC2}$	Average $V_{CC}$ current during STORE	All inputs don't care, $V_{CC} = \text{Max}$ Average current for duration $t_{STORE}$	-	-	10	mA
$I_{CC3}$	Average $V_{CC}$ current at $t_{RC} = 200$ ns, $V_{CC(Typ)}$ , 25 °C	All inputs cycling at CMOS levels. Values obtained without output loads ( $I_{OUT} = 0$ mA).	-	35	-	mA
$I_{CC4}$	Average $V_{CAP}$ current during AutoStore cycle	All inputs don't care. Average current for duration $t_{STORE}$	-	-	5	mA
$I_{SB}$	$V_{CC}$ standby current	$CE \geq (V_{CC} - 0.2$ V). $V_{IN} \leq 0.2$ V or $\geq (V_{CC} - 0.2$ V). Standby current level after non-volatile cycle is complete. Inputs are static. $f = 0$ MHz.	-	-	5	mA
$I_{IX}^{[16]}$	Input leakage current (except HSB)	$V_{CC} = \text{Max}$ , $V_{SS} \leq V_{IN} \leq V_{CC}$	-1	-	+1	$\mu$ A
	Input leakage current (for HSB)	$V_{CC} = \text{Max}$ , $V_{SS} \leq V_{IN} \leq V_{CC}$	-100	-	+1	$\mu$ A
$I_{OZ}$	Off-state output leakage current	$V_{CC} = \text{Max}$ , $V_{SS} \leq V_{OUT} \leq V_{CC}$ , $CE$ or $OE \geq V_{IH}$ or $BHE/BLE \geq V_{IH}$ or $WE \leq V_{IL}$	-1	-	+1	$\mu$ A
$V_{IH}$	Input HIGH voltage		2.0	-	$V_{CC} + 0.5$	V
$V_{IL}$	Input LOW voltage		$V_{SS} - 0.5$	-	0.8	V
$V_{OH}$	Output HIGH voltage	$I_{OUT} = -2$ mA	2.4	-	-	V
$V_{OL}$	Output LOW voltage	$I_{OUT} = 4$ mA	-	-	0.4	V
$V_{CAP}^{[17]}$	Storage capacitor	Between $V_{CAP}$ pin and $V_{SS}$ . 5 V rated	61	68	180	$\mu$ F

### Notes

15. Typical values are at 25 °C.  $V_{CC} = V_{CC(Typ)}$ . Not 100% tested.

16. The HSB pin has  $I_{OUT} = -2$   $\mu$ A for  $V_{OH}$  of 2.4 V when both active HIGH and LOW drivers are disabled. When they are enabled standard  $V_{OH}$  and  $V_{OL}$  are valid. This parameter is characterized but not tested.

17. Min  $V_{CAP}$  value guarantees that there is a sufficient charge available to complete a successful AutoStore operation. Max  $V_{CAP}$  value guarantees that the capacitor on  $V_{CAP}$  is charged to a minimum voltage during a Power-Up RECALL cycle so that an immediate power-down cycle can complete a successful AutoStore. Therefore it is always recommended to use a capacitor within the specified min and max limits. Refer application note [AN43593](#) for more details on  $V_{CAP}$  options.

## Data Retention and Endurance

Over the [Operating Range](#)

Parameter	Description	Min	Unit
DATA <sub>R</sub>	Data retention	20	Years
NV <sub>C</sub>	Non-volatile STORE operations	1,000	K

## Capacitance

Parameter <sup>[18]</sup>	Description	Test Conditions	Max	Unit
C <sub>IN</sub>	Input capacitance (except BHE, BLE and HSB)	T <sub>A</sub> = 25 °C, f = 1 MHz, V <sub>CC</sub> = V <sub>CC(Typ)</sub>	7	pF
	Input capacitance (for BHE, BLE and HSB)		8	pF
C <sub>OUT</sub>	Output capacitance (except HSB)		7	pF
	Output capacitance (for HSB)		8	pF

## Thermal Resistance

Parameter <sup>[18]</sup>	Description	Test Conditions	48-pin FBGA	44-pin TSOP II	54-pin TSOP II	Unit
Θ <sub>JA</sub>	Thermal resistance (junction to ambient)	Test conditions follow standard test methods and procedures for measuring thermal impedance, in accordance with EIA/JESD51.	46.09	43.3	42.03	°C/W
Θ <sub>JC</sub>	Thermal resistance (junction to case)		7.84	5.56	6.08	°C/W

## AC Test Loads

Figure 5. AC Test Loads

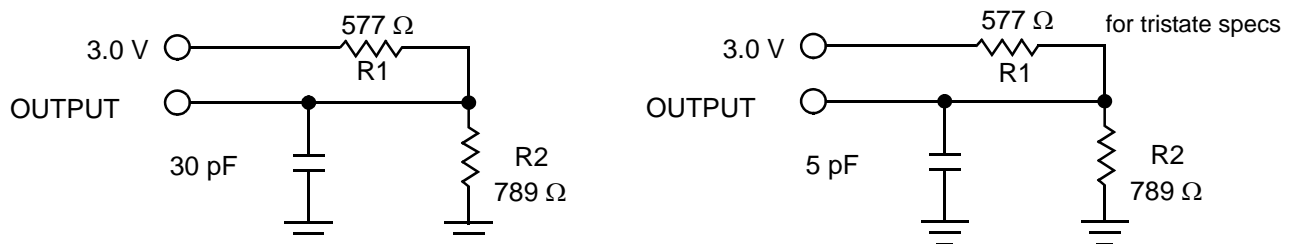

## AC Test Conditions

Input pulse levels ..... 0 V to 3 V  
 Input rise and fall times (10%–90%) ..... ≤ 3 ns  
 Input and output timing reference levels ..... 1.5 V

**Note**

18. These parameters are guaranteed by design but not tested.

## AC Switching Characteristics

Over the [Operating Range](#)

Parameters <sup>[19]</sup>		Description	20 ns		25 ns		45 ns		Unit
Cypress Parameter	Alt Parameter		Min	Max	Min	Max	Min	Max	
<b>SRAM Read Cycle</b>									
$t_{ACE}$	$t_{ACS}$	Chip enable access time	–	20	–	25	–	45	ns
$t_{RC}^{[20]}$	$t_{RC}$	Read cycle time	20	–	25	–	45	–	ns
$t_{AA}^{[21]}$	$t_{AA}$	Address access time	–	20	–	25	–	45	ns
$t_{DOE}$	$t_{OE}$	Output enable to data valid	–	10	–	12	–	20	ns
$t_{OHA}^{[21]}$	$t_{OH}$	Output hold after address change	3	–	3	–	3	–	ns
$t_{LZCE}^{[22, 23]}$	$t_{LZ}$	Chip enable to output active	3	–	3	–	3	–	ns
$t_{HZCE}^{[22, 23]}$	$t_{HZ}$	Chip disable to output inactive	–	8	–	10	–	15	ns
$t_{LZOE}^{[22, 23]}$	$t_{OLZ}$	Output enable to output active	0	–	0	–	0	–	ns
$t_{HZOE}^{[22, 23]}$	$t_{OHZ}$	Output disable to output inactive	–	8	–	10	–	15	ns
$t_{PU}^{[22]}$	$t_{PA}$	Chip enable to power active	0	–	0	–	0	–	ns
$t_{PD}^{[22]}$	$t_{PS}$	Chip disable to power standby	–	20	–	25	–	45	ns
$t_{DBE}$	–	Byte enable to data valid	–	10	–	12	–	20	ns
$t_{LZBE}^{[22]}$	–	Byte enable to output active	0	–	0	–	0	–	ns
$t_{HZBE}^{[22]}$	–	Byte disable to output inactive	–	8	–	10	–	15	ns
<b>SRAM Write Cycle</b>									
$t_{WC}$	$t_{WC}$	Write cycle time	20	–	25	–	45	–	ns
$t_{PWE}$	$t_{WP}$	Write pulse width	15	–	20	–	30	–	ns
$t_{SCE}$	$t_{CW}$	Chip enable to end of write	15	–	20	–	30	–	ns
$t_{SD}$	$t_{DW}$	Data setup to end of write	8	–	10	–	15	–	ns
$t_{HD}$	$t_{DH}$	Data hold after end of write	0	–	0	–	0	–	ns
$t_{AW}$	$t_{AW}$	Address setup to end of write	15	–	20	–	30	–	ns
$t_{SA}$	$t_{AS}$	Address setup to start of write	0	–	0	–	0	–	ns
$t_{HA}$	$t_{WR}$	Address hold after end of write	0	–	0	–	0	–	ns
$t_{HZWE}^{[22, 23, 24]}$	$t_{WZ}$	Write enable to output disable	–	8	–	10	–	15	ns
$t_{LZWE}^{[22, 23]}$	$t_{OW}$	Output active after end of write	3	–	3	–	3	–	ns
$t_{BW}$	–	Byte enable to end of write	15	–	20	–	30	–	ns

## Switching Waveforms

Figure 6. SRAM Read Cycle #1 (Address Controlled) <sup>[20, 21, 25]</sup>

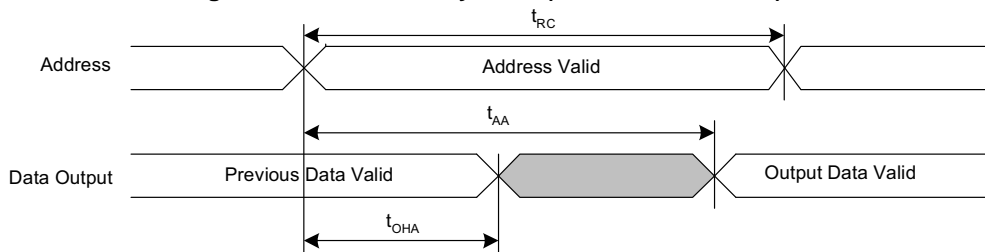

### Notes

19. Test conditions assume signal transition time of 3 ns or less, timing reference levels of  $V_{CC}/2$ , input pulse levels of 0 to  $V_{CC(typ)}$ , and output loading of the specified  $I_{OL}/I_{OH}$  and load capacitance shown in [Figure 5 on page 10](#).
20. WE must be HIGH during SRAM read cycles.
21. Device is continuously selected with CE, OE and  $\overline{BHE} / \overline{BLE}$  LOW.
22. These parameters are guaranteed by design but not tested.
23. Measured  $\pm 200$  mV from steady state output voltage.
24. If WE is LOW when CE goes LOW, the outputs remain in the high impedance state.
25. HSB must remain HIGH during read and write cycles.

Switching Waveforms (continued)

Figure 7. SRAM Read Cycle #2 ( $\overline{CE}$  and  $\overline{OE}$  Controlled) [26, 27, 28]

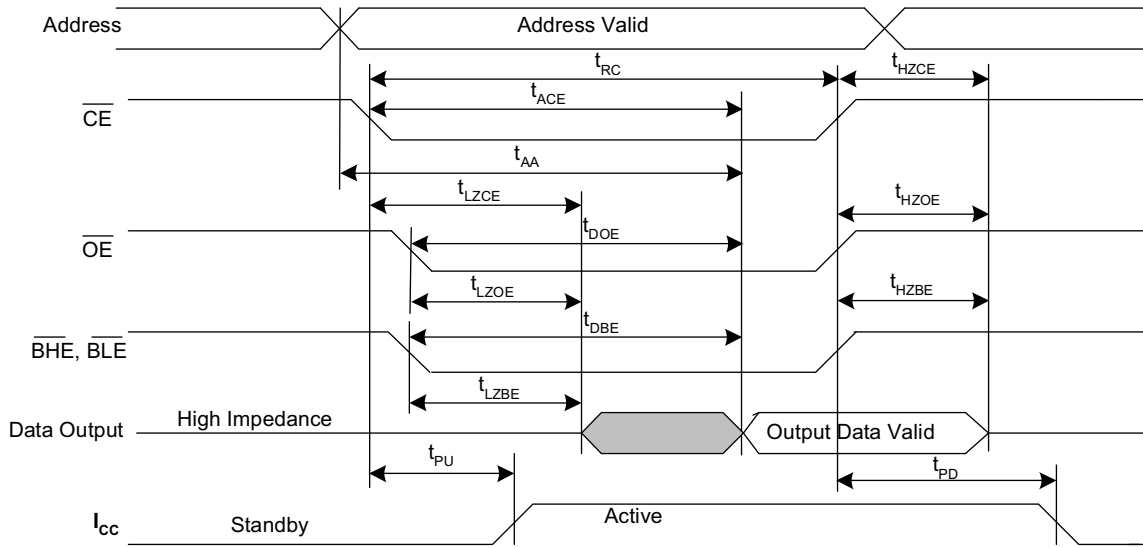
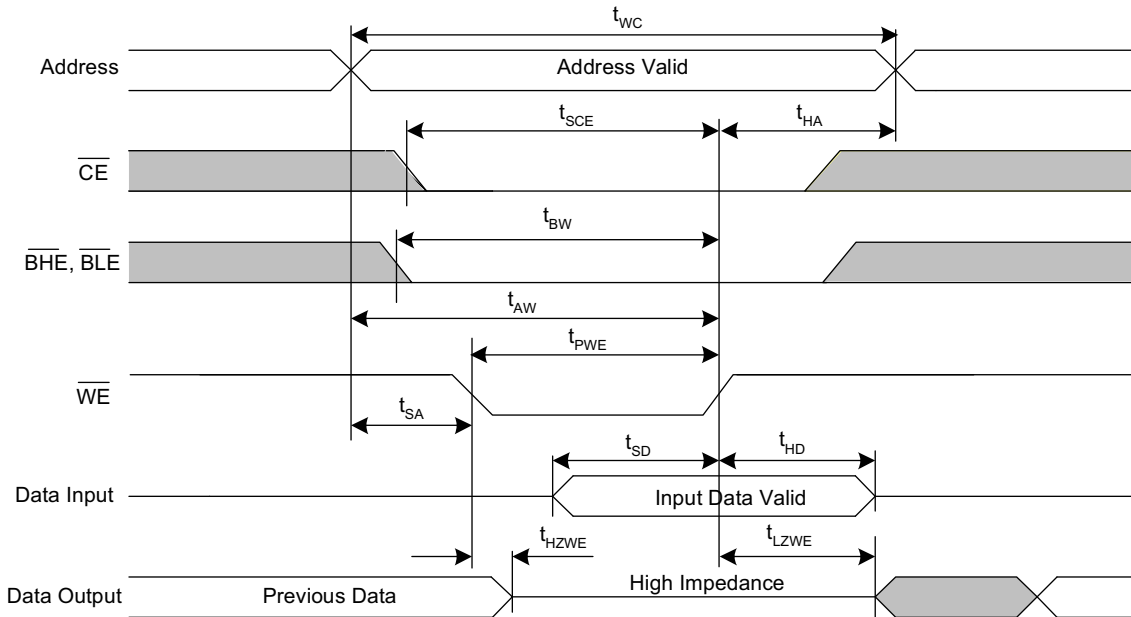

Figure 8. SRAM Write Cycle #1 ( $\overline{WE}$  Controlled) [26, 28, 29, 30]



Notes

- 26.  $\overline{BHE}$  and  $\overline{BLE}$  are applicable for x 16 configuration only.
- 27.  $\overline{WE}$  must be HIGH during SRAM read cycles.
- 28.  $\overline{HSB}$  must remain HIGH during read and write cycles.
- 29. If  $\overline{WE}$  is LOW when  $\overline{CE}$  goes LOW, the outputs remain in the high impedance state.
- 30.  $\overline{CE}$  or  $\overline{WE}$  must be  $\geq V_{IH}$  during address transitions.

Switching Waveforms (continued)

Figure 9. SRAM Write Cycle #2 ( $\overline{\text{CE}}$  Controlled) [31, 32, 33, 34]

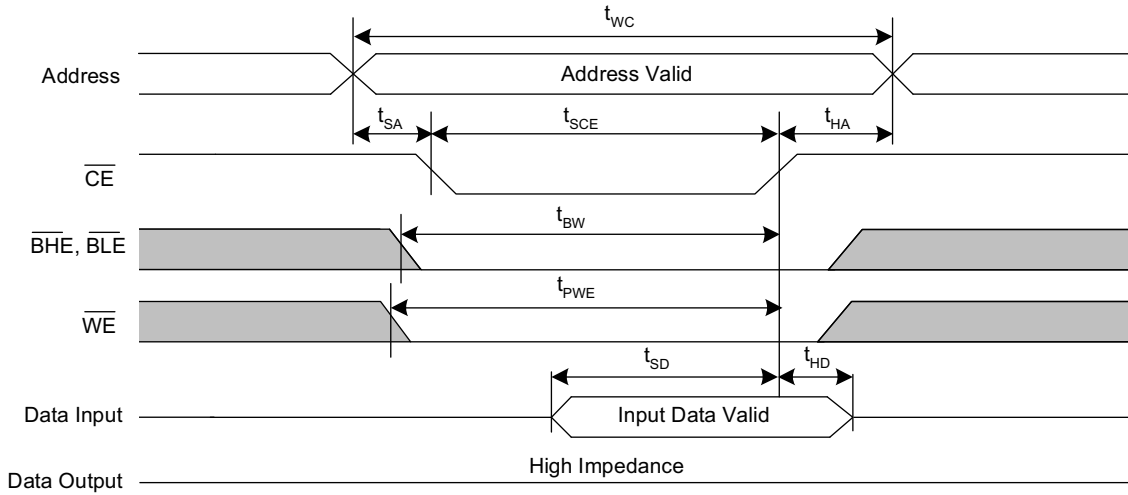
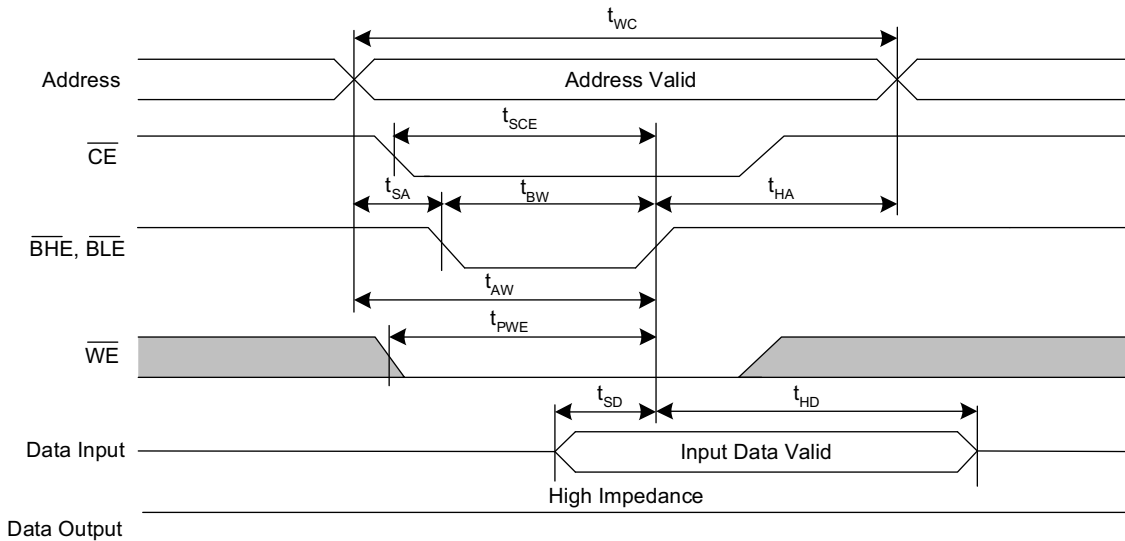

Figure 10. SRAM Write Cycle #3 ( $\overline{\text{BHE}}$  and  $\overline{\text{BLE}}$  Controlled) [31, 32, 33, 34]



Notes

- 31.  $\overline{\text{BHE}}$  and  $\overline{\text{BLE}}$  are applicable for x 16 configuration only.
- 32. If  $\overline{\text{WE}}$  is LOW when  $\overline{\text{CE}}$  goes LOW, the outputs remain in the high impedance state.
- 33.  $\overline{\text{HSB}}$  must remain HIGH during read and write cycles.
- 34.  $\overline{\text{CE}}$  or  $\overline{\text{WE}}$  must be  $\geq V_{IH}$  during address transitions.

## AutoStore/Power-Up RECALL

Over the [Operating Range](#)

Parameter	Description	20 ns		25 ns		45 ns		Unit
		Min	Max	Min	Max	Min	Max	
$t_{HRECALL}^{[35]}$	Power-Up RECALL duration	–	20	–	20	–	20	ms
$t_{STORE}^{[36]}$	STORE cycle duration	–	8	–	8	–	8	ms
$t_{DELAY}^{[37]}$	Time allowed to complete SRAM write cycle	–	20	–	25	–	25	ns
$V_{SWITCH}$	Low voltage trigger level	–	2.65	–	2.65	–	2.65	V
$t_{VCCRRISE}^{[38]}$	$V_{CC}$ rise time	150	–	150	–	150	–	$\mu$ s
$V_{HDIS}^{[38]}$	HSB output disable voltage	–	1.9	–	1.9	–	1.9	V
$t_{LZHSB}^{[38]}$	HSB to output active time	–	5	–	5	–	5	$\mu$ s
$t_{HHHD}^{[38]}$	HSB high active time	–	500	–	500	–	500	ns

## Switching Waveforms

Figure 11. AutoStore or Power-Up RECALL <sup>[39]</sup>

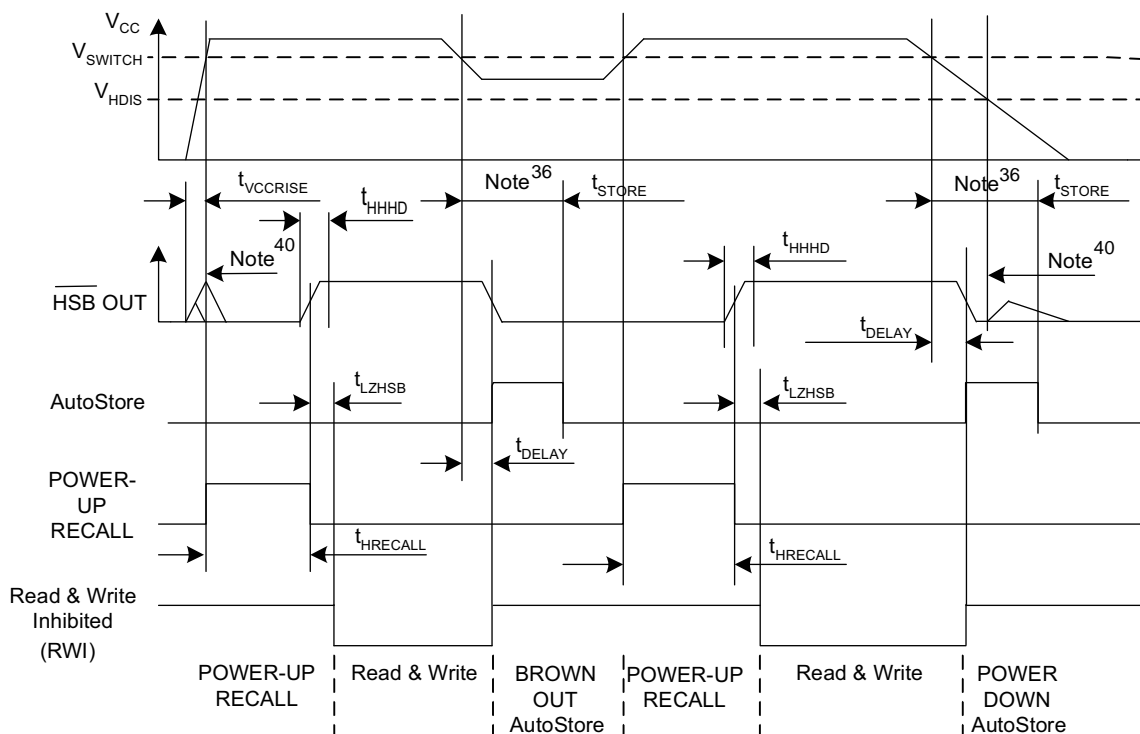

### Notes

- 35.  $t_{HRECALL}$  starts from the time  $V_{CC}$  rises above  $V_{SWITCH}$ .
- 36. If an SRAM write has not taken place since the last non-volatile cycle, no AutoStore or Hardware STORE takes place.
- 37. On a Hardware STORE and AutoStore initiation, SRAM write operation continues to be enabled for time  $t_{DELAY}$ .
- 38. These parameters are guaranteed by design but not tested.
- 39. Read and write cycles are ignored during STORE, RECALL, and while  $V_{CC}$  is below  $V_{SWITCH}$ .
- 40. During power-up and power-down, HSB glitches when HSB pin is pulled up through an external resistor.





## Hardware STORE Cycle

Over the [Operating Range](#)

Parameter	Description	20 ns		25 ns		45 ns		Unit
		Min	Max	Min	Max	Min	Max	
$t_{DHSB}$	HSB to output active time when write latch not set	–	20	–	25	–	25	ns
$t_{PHSB}$	Hardware STORE pulse width	15	–	15	–	15	–	ns
$t_{SS}^{[44, 45]}$	Soft sequence processing time	–	100	–	100	–	100	$\mu$ s

## Switching Waveforms

Figure 14. Hardware STORE Cycle <sup>[46]</sup>

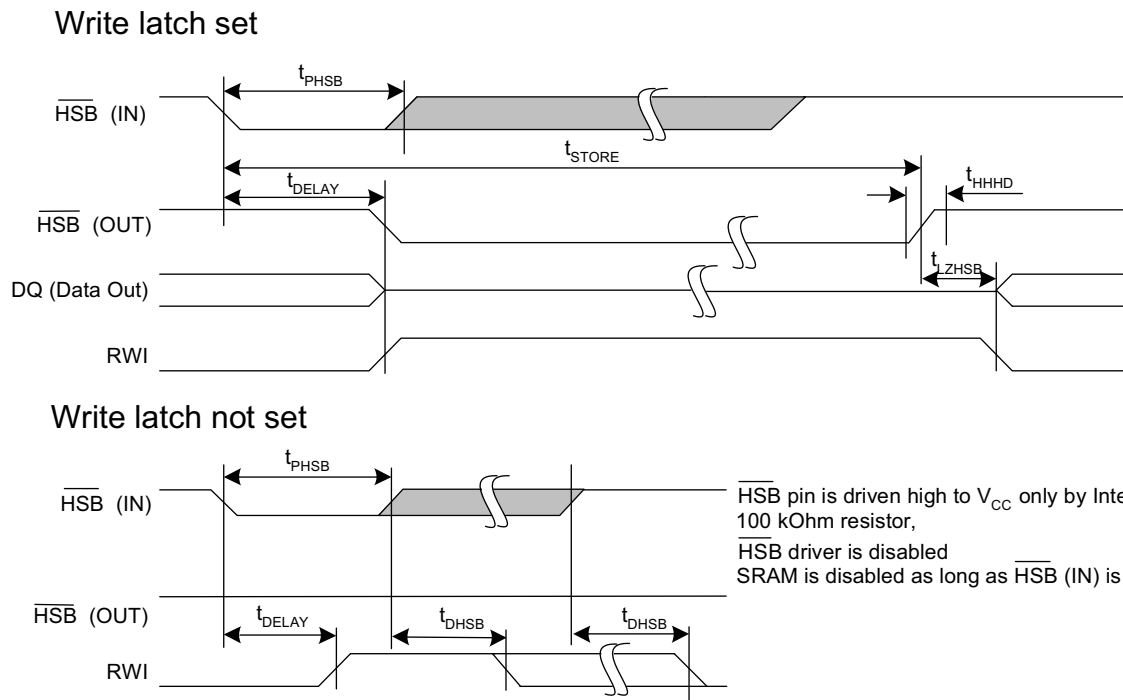
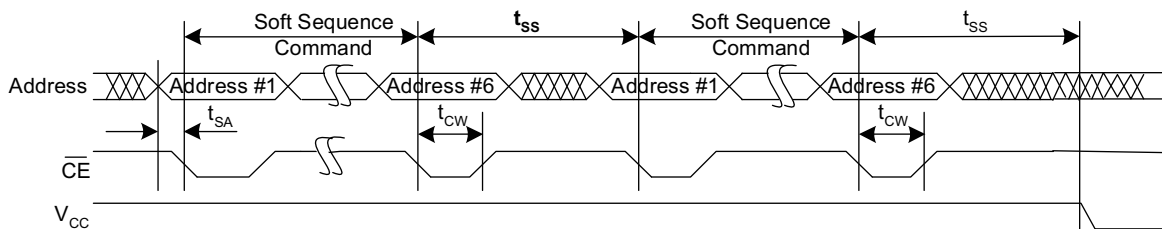

Figure 15. Soft Sequence Processing <sup>[44, 45]</sup>



### Notes

- 44. This is the amount of time it takes to take action on a soft sequence command.  $V_{CC}$  power must remain HIGH to effectively register command.
- 45. Commands such as STORE and RECALL lock out I/O until operation is complete which further increases this time. See the specific command.
- 46. If an SRAM write has not taken place since the last non-volatile cycle, no AutoStore or Hardware STORE takes place.

## Truth Table For SRAM Operations

$\overline{\text{HSB}}$  should remain HIGH for SRAM Operations.

**Table 2. Truth Table for × 8 Configuration**

$\overline{\text{CE}}$	$\overline{\text{WE}}$	$\overline{\text{OE}}$	Inputs/Outputs <sup>[47]</sup>	Mode	Power
H	X	X	High Z	Deselect/Power-down	Standby
L	H	L	Data out (DQ <sub>0</sub> –DQ <sub>7</sub> );	Read	Active
L	H	H	High Z	Output disabled	Active
L	L	X	Data in (DQ <sub>0</sub> –DQ <sub>7</sub> );	Write	Active

**Table 3. Truth Table for × 16 Configuration**

$\overline{\text{CE}}$	$\overline{\text{WE}}$	$\overline{\text{OE}}$	$\overline{\text{BHE}}$ <sup>[48]</sup>	$\overline{\text{BLE}}$ <sup>[48]</sup>	Inputs/Outputs <sup>[47]</sup>	Mode	Power
H	X	X	X	X	High Z	Deselect/Power-down	Standby
L	X	X	H	H	High Z	Output disabled	Active
L	H	L	L	L	Data out (DQ <sub>0</sub> –DQ <sub>15</sub> )	Read	Active
L	H	L	H	L	Data out (DQ <sub>0</sub> –DQ <sub>7</sub> ); DQ <sub>8</sub> –DQ <sub>15</sub> in High Z	Read	Active
L	H	L	L	H	Data out (DQ <sub>8</sub> –DQ <sub>15</sub> ); DQ <sub>0</sub> –DQ <sub>7</sub> in High Z	Read	Active
L	H	H	L	L	High Z	Output disabled	Active
L	H	H	H	L	High Z	Output disabled	Active
L	H	H	L	H	High Z	Output disabled	Active
L	L	X	L	L	Data in (DQ <sub>0</sub> –DQ <sub>15</sub> )	Write	Active
L	L	X	H	L	Data in (DQ <sub>0</sub> –DQ <sub>7</sub> ); DQ <sub>8</sub> –DQ <sub>15</sub> in High Z	Write	Active
L	L	X	L	H	Data in (DQ <sub>8</sub> –DQ <sub>15</sub> ); DQ <sub>0</sub> –DQ <sub>7</sub> in High Z	Write	Active

**Notes**

47. Data DQ<sub>0</sub>–DQ<sub>7</sub> for × 8 configuration and Data DQ<sub>0</sub>–DQ<sub>15</sub> for × 16 configuration.

48. BHE and BLE are applicable for × 16 configuration only.

**Ordering Information**

Speed (ns)	Ordering Code	Package Diagram	Package Type	Operating Range
20	CY14B104LA-ZS20XIT	51-85087	44-pin TSOP II	Industrial
	CY14B104LA-ZS20XI	51-85087	44-pin TSOP II	
	CY14B104NA-ZS20XIT	51-85087	44-pin TSOP II	
	CY14B104NA-ZS20XI	51-85087	44-pin TSOP II	
	CY14B104NA-BA20XIT	51-85128	48-ball FBGA	
	CY14B104NA-BA20XI	51-85128	48-ball FBGA	
25	CY14B104LA-ZS25XIT	51-85087	44-pin TSOP II	
	CY14B104LA-ZS25XI	51-85087	44-pin TSOP II	
	CY14B104LA-BA25XIT	51-85128	48-ball FBGA	
	CY14B104LA-BA25XI	51-85128	48-ball FBGA	
	CY14B104NA-ZS25XIT	51-85087	44-pin TSOP II	
	CY14B104NA-ZS25XI	51-85087	44-pin TSOP II	
	CY14B104NA-BA25XIT	51-85128	48-ball FBGA	
	CY14B104NA-BA25XI	51-85128	48-ball FBGA	
	CY14B104NA-BA25I	51-85128	48-ball FBGA	
	CY14B104NA-ZSP25XIT	51-85160	54-pin TSOP II	
	CY14B104NA-ZSP25XI	51-85160	54-pin TSOP II	
	45	CY14B104LA-ZS45XIT	51-85087	
CY14B104LA-ZS45XI		51-85087	44-pin TSOP II	
CY14B104LA-BA45XIT		51-85128	48-ball FBGA	
CY14B104LA-BA45XI		51-85128	48-ball FBGA	
CY14B104NA-ZS45XIT		51-85087	44-pin TSOP II	
CY14B104NA-ZS45XI		51-85087	44-pin TSOP II	
CY14B104NA-BA45XIT		51-85128	48-ball FBGA	
CY14B104NA-BA45XI		51-85128	48-ball FBGA	
CY14B104NA-ZSP45XIT		51-85160	54-pin TSOP II	
CY14B104NA-ZSP45XI		51-85160	54-pin TSOP II	

**Ordering Code Definitions**

**CY 14 B 104 L A - ZS 20 X I T**

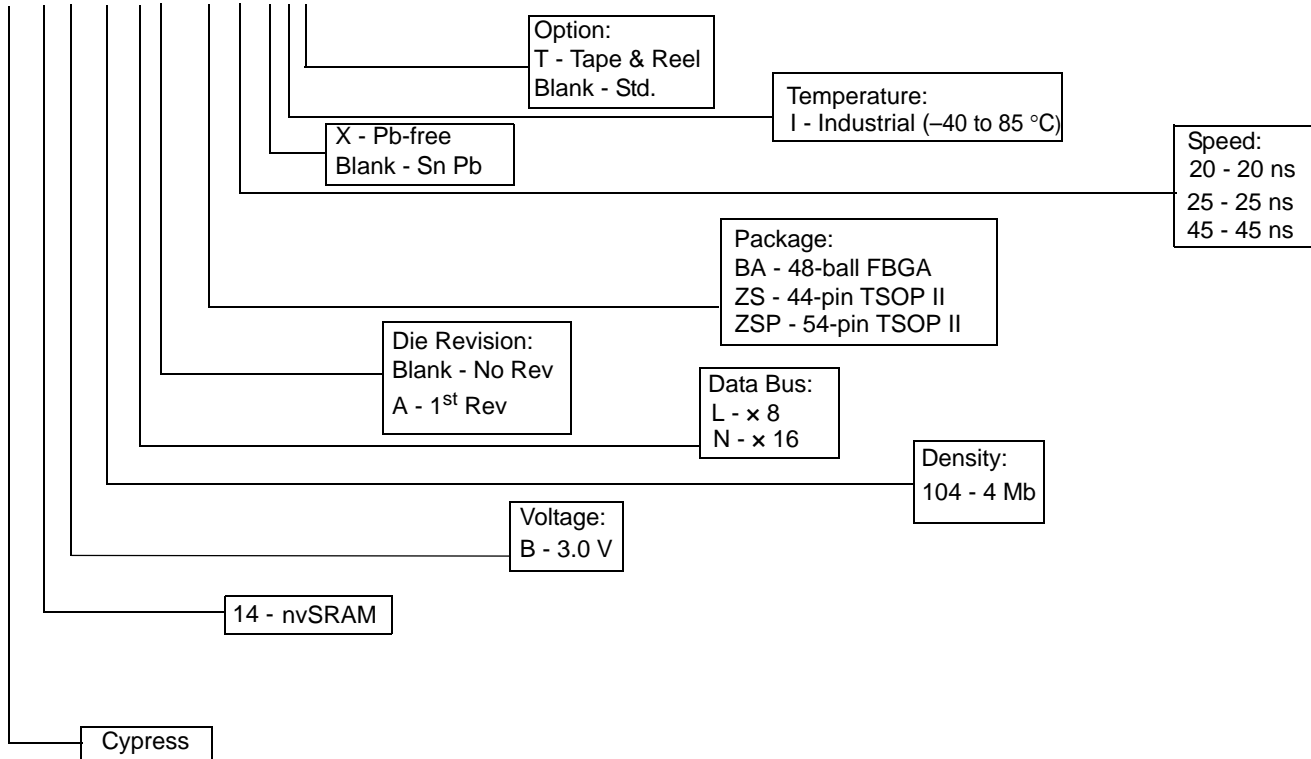

Package Diagrams

Figure 16. 44-pin TSOP II, 51-85087

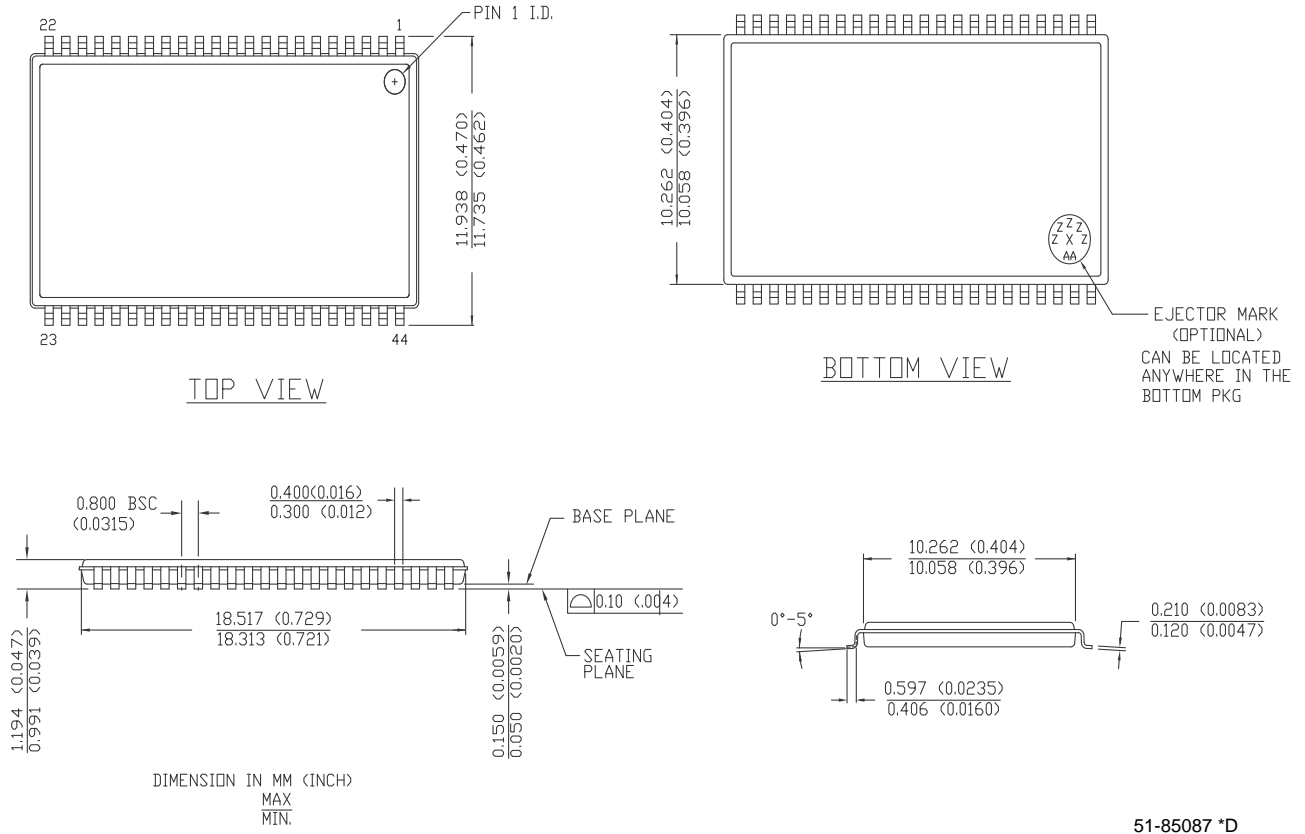



Package Diagrams (continued)

Figure 17. 48-ball FBGA (6 × 10 × 1.2 mm), 51-85128

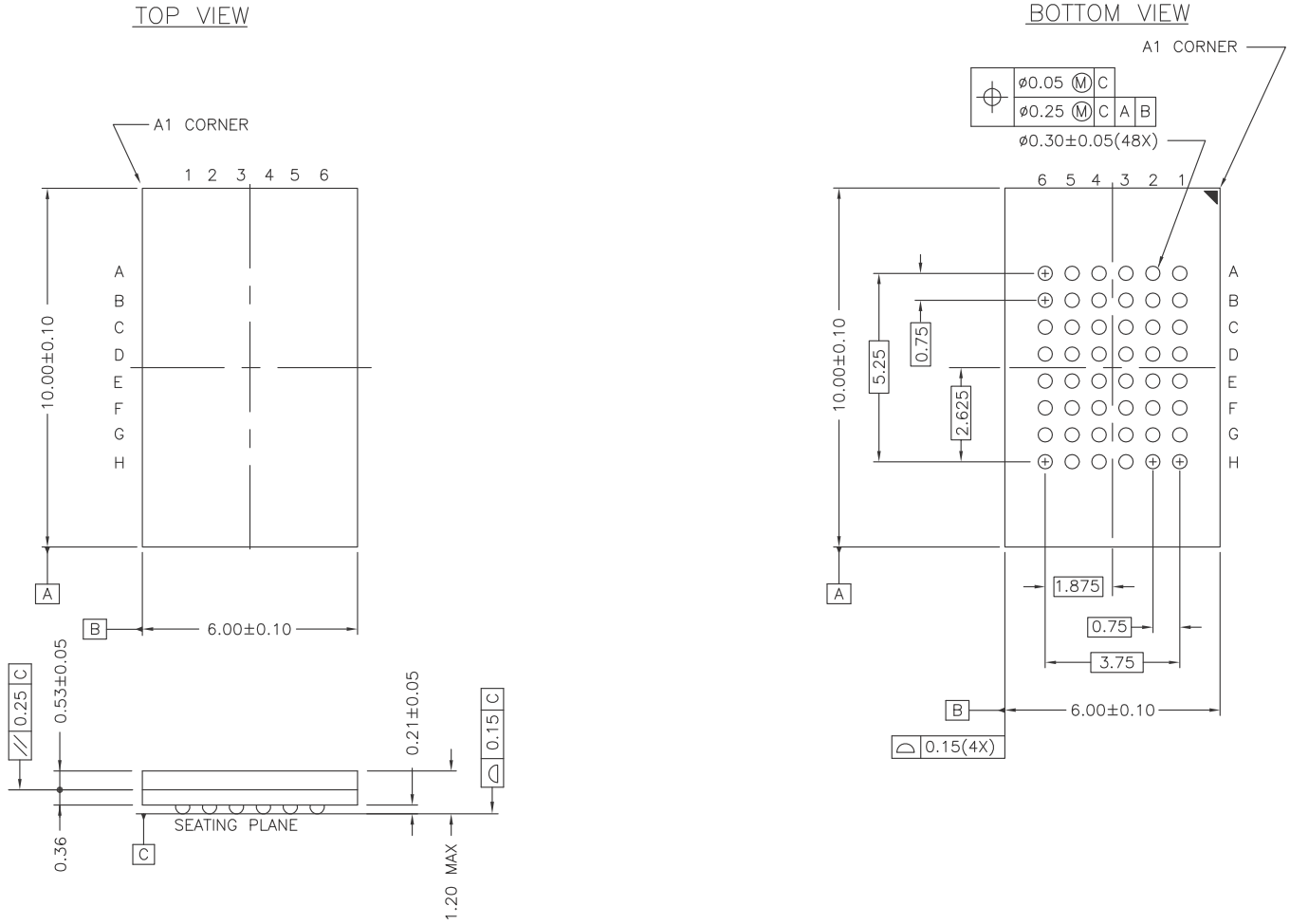

51-85128 \*F

Package Diagrams (continued)

Figure 18. 54-pin TSOP II (22.4 x 11.84 x 1.0 mm), 51-85160

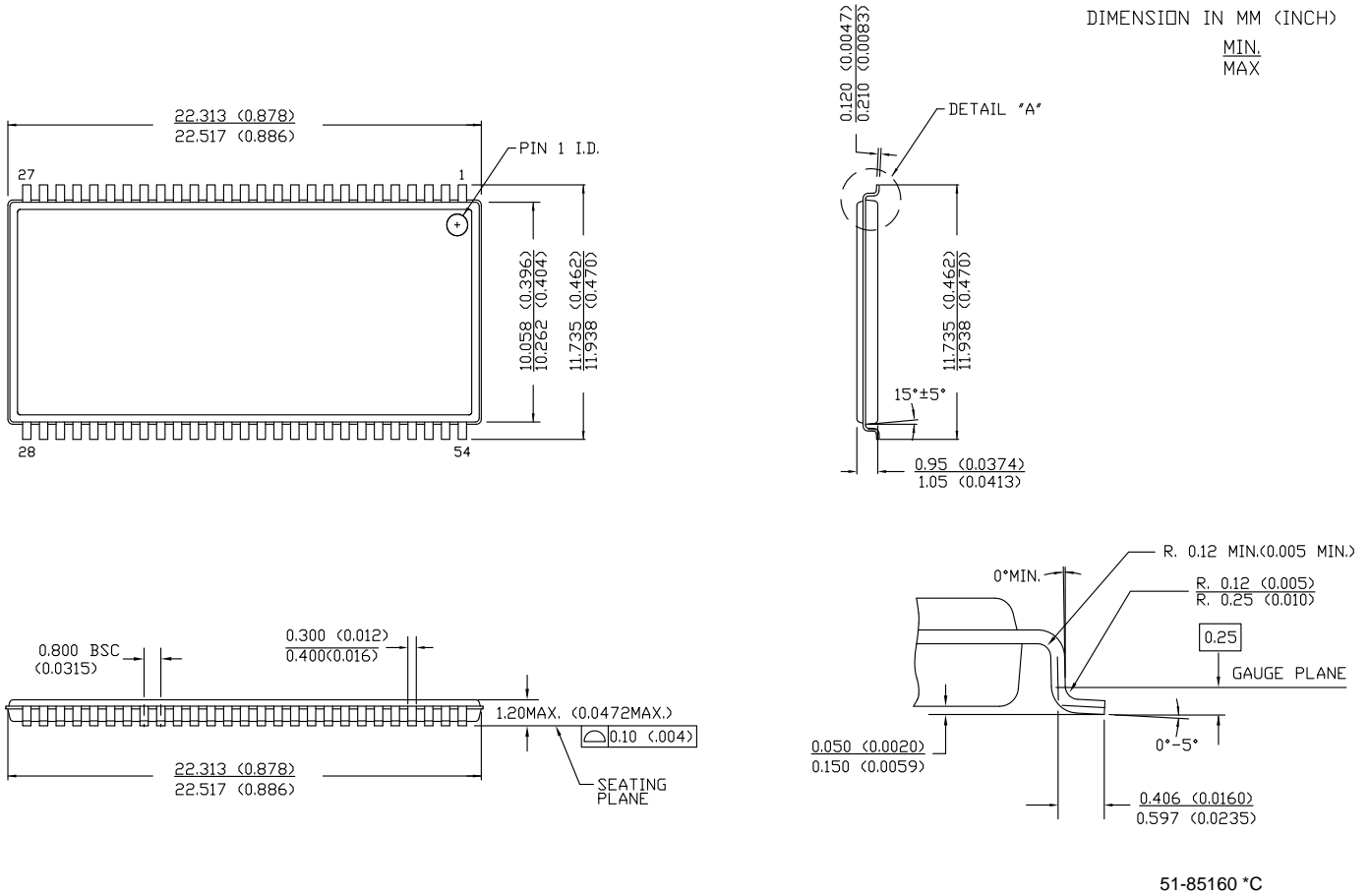

## Acronyms

Acronym	Description
BHE	byte high enable
BLE	byte low enable
CE	chip enable
CMOS	complementary metal oxide semiconductor
EIA	electronic industries alliance
FBGA	fine-pitch ball grid array
HSB	hardware store busy
I/O	input/output
nvSRAM	non-volatile static random access memory
OE	output enable
RoHS	restriction of hazardous substances
RWI	read and write inhibited
SRAM	static random access memory
TSOP	thin small outline package
WE	write enable

## Document Conventions

### Units of Measure

Symbol	Unit of Measure
°C	degree Celsius
Hz	hertz
kHz	kilohertz
kΩ	kilo-ohm
MHz	megahertz
μA	microampere
μF	microfarad
μs	microsecond
mA	milliampere
ms	millisecond
ns	nanosecond
Ω	ohm
%	percent
pF	picofarad
V	volt
W	watt

Document History Page

Document Title: CY14B104LA/CY14B104NA, 4-Mbit (512 K × 8/256 K × 16) nvSRAM				
Document Number: 001-49918				
Revision	ECN	Orig. of Change	Submission Date	Description of Change
**	2606696	GVCH / PYRS	11/13/08	New Datasheet
*A	2672700	GVCH / PYRS	03/12/09	Added best practices Added CY14B104NA-BA251 part number Added footnote12 for HZ/LZ parameters
*B	2710274	GVCH / AESA	05/22/09	Moved datasheet status from Preliminary to Final Updated AutoStore operation Updated I <sub>SB</sub> test condition Updated footnote 9 Referenced footnote 12 to V <sub>CCRISE</sub> , t <sub>HHD</sub> and t <sub>LZHSB</sub> parameters Updated V <sub>HDIS</sub> parameter description Updated figure 12
*C	2738586	GVCH	07/15/09	Page 4: Updated Hardware STORE Operation description Page 5: Updated Software STORE description Updated t <sub>DELAY</sub> parameter description Updated footnote 20 Added footnote 25 referenced footnote 25 to figure 12 and figure 13
*D	2758397	GVCH / AESA	09/01/09	Removed commercial temperature related specifications
*E	2773362	GVCH	10/06/09	Ordering Information: Added 20 ns part in a 48-FBGA package
*F	2826364	GVCH / PYRS	12/11/09	Changed STORE cycles to QuantumTrap from 200K to 1 Million
*G	2923475	GVCH / AESA	04/27/2010	<a href="#">Table 1</a> : Added more clarity on HSB pin operation <a href="#">Hardware STORE Operation</a> : Added more clarity on HSB pin operation <a href="#">Table 1</a> : Added more clarity on BHE/BLE pin operation Updated HSB pin operation in <a href="#">Figure 11</a> Updated footnote 22 Updated <a href="#">Package Diagrams</a> and <a href="#">Sales, Solutions, and Legal Information</a> .
*H	3132368	GVCH	01/10/2011	48-ball FBGA package: 16 Mb address expansion is not supported Updated input capacitance for BHE and BLE pin Updated input and output capacitance for HSB pin Fixed typo in <a href="#">Figure 11</a> Added <a href="#">Acronyms</a> table and <a href="#">Document Conventions</a> table.
*I	3305495	GVCH	07/07/2011	Updated <a href="#">DC Electrical Characteristics</a> (Added <a href="#">Note 17</a> and referred the same note in V <sub>CAP</sub> parameter). Updated <a href="#">AC Switching Characteristics</a> (Added <a href="#">Note 19</a> and referred the same note in Parameters). Updated <a href="#">Thermal Resistance</a> (Values of Θ <sub>JA</sub> for all packages). Updated <a href="#">Package Diagrams</a> .
*J	3389991	GVCH	09/30/2011	Updated <a href="#">Package Diagrams</a>

## Sales, Solutions, and Legal Information

### Worldwide Sales and Design Support

Cypress maintains a worldwide network of offices, solution centers, manufacturer's representatives, and distributors. To find the office closest to you, visit us at [Cypress Locations](#).

### Products

<a href="#">Automotive</a>	<a href="http://cypress.com/go/automotive">cypress.com/go/automotive</a>
<a href="#">Clocks &amp; Buffers</a>	<a href="http://cypress.com/go/clocks">cypress.com/go/clocks</a>
<a href="#">Interface</a>	<a href="http://cypress.com/go/interface">cypress.com/go/interface</a>
<a href="#">Lighting &amp; Power Control</a>	<a href="http://cypress.com/go/powerpsoc">cypress.com/go/powerpsoc</a> <a href="http://cypress.com/go/plc">cypress.com/go/plc</a>
<a href="#">Memory</a>	<a href="http://cypress.com/go/memory">cypress.com/go/memory</a>
<a href="#">Optical &amp; Image Sensing</a>	<a href="http://cypress.com/go/image">cypress.com/go/image</a>
<a href="#">PSoC</a>	<a href="http://cypress.com/go/psoc">cypress.com/go/psoc</a>
<a href="#">Touch Sensing</a>	<a href="http://cypress.com/go/touch">cypress.com/go/touch</a>
<a href="#">USB Controllers</a>	<a href="http://cypress.com/go/USB">cypress.com/go/USB</a>
<a href="#">Wireless/RF</a>	<a href="http://cypress.com/go/wireless">cypress.com/go/wireless</a>

### PSoC Solutions

[psoc.cypress.com/solutions](http://psoc.cypress.com/solutions)  
PSoC 1 | PSoC 3 | PSoC 5

---

© Cypress Semiconductor Corporation, 2008-2011. The information contained herein is subject to change without notice. Cypress Semiconductor Corporation assumes no responsibility for the use of any circuitry other than circuitry embodied in a Cypress product. Nor does it convey or imply any license under patent or other rights. Cypress products are not warranted nor intended to be used for medical, life support, life saving, critical control or safety applications, unless pursuant to an express written agreement with Cypress. Furthermore, Cypress does not authorize its products for use as critical components in life-support systems where a malfunction or failure may reasonably be expected to result in significant injury to the user. The inclusion of Cypress products in life-support systems application implies that the manufacturer assumes all risk of such use and in doing so indemnifies Cypress against all charges.

Any Source Code (software and/or firmware) is owned by Cypress Semiconductor Corporation (Cypress) and is protected by and subject to worldwide patent protection (United States and foreign), United States copyright laws and international treaty provisions. Cypress hereby grants to licensee a personal, non-exclusive, non-transferable license to copy, use, modify, create derivative works of, and compile the Cypress Source Code and derivative works for the sole purpose of creating custom software and or firmware in support of licensee product to be used only in conjunction with a Cypress integrated circuit as specified in the applicable agreement. Any reproduction, modification, translation, compilation, or representation of this Source Code except as specified above is prohibited without the express written permission of Cypress.

Disclaimer: CYPRESS MAKES NO WARRANTY OF ANY KIND, EXPRESS OR IMPLIED, WITH REGARD TO THIS MATERIAL, INCLUDING, BUT NOT LIMITED TO, THE IMPLIED WARRANTIES OF MERCHANTABILITY AND FITNESS FOR A PARTICULAR PURPOSE. Cypress reserves the right to make changes without further notice to the materials described herein. Cypress does not assume any liability arising out of the application or use of any product or circuit described herein. Cypress does not authorize its products for use as critical components in life-support systems where a malfunction or failure may reasonably be expected to result in significant injury to the user. The inclusion of Cypress' product in a life-support systems application implies that the manufacturer assumes all risk of such use and in doing so indemnifies Cypress against all charges.

Use may be limited by and subject to the applicable Cypress software license agreement.