



HFU1N60

APPLICATIONS

high-Speed Switching.

ABSOLUTE MAXIMUM RATINGS ($T_a=25$)

T_{stg}	Storage Temperature.....	-55~150
T_j	Operating Junction Temperature	150
P_D	Allowable Power Dissipation ($T_c=25$)	28W
V_{DSS}	Drain-Source Voltage	600V
V_{GSS}	Gate-Source Voltage	$\pm 30V$
I_D	Drain Current ($T_c=25$)	1A
I_{DM}	Drain Current (Pulsed)	4A

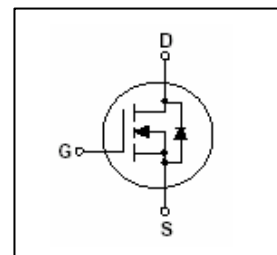
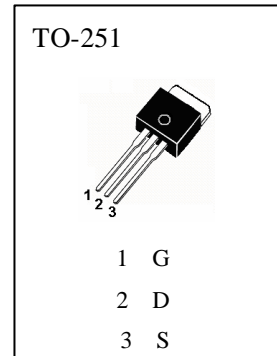

ELECTRICAL CHARACTERISTICS ($T_a=25$)

Symbol	Characteristics	Min	Typ	Max	Unit	Test Conditions
BV_{DSS}	Drain-Source Breakdown Voltage	600			V	$I_D=250 \mu A, V_{GS}=0V$
I_{DSS}	Zero Gate Voltage Drain Current			1	μA	$V_{DS}=600V, V_{GS}=0$
I_{GSS}	Gate -Source Leakage Current			± 100	nA	$V_{GS}=\pm 30V, V_{DS}=0V$
$V_{GS(th)}$	Gate Threshold Voltage	2.5		4.5	V	$V_{DS}=V_{GS}, I_D=250 \mu A$
$R_{DS(on)}$	Static Drain-Source On-Resistance		9.3	11.5	Ω	$V_{GS}=10V, I_D=0.5A$
g_{FS}	Forward Transconductance		0.75		S	$V_{DS}=40V, I_D=0.5A^*$
C_{iss}	Input Capacitance		130	170	pF	$V_{DS}=25V, V_{GS}=0, f=1MHz$
C_{oss}	Output Capacitance		19	25	pF	
C_{rss}	Reverse Transfer Capacitance		3.5	4.5	pF	
$t_{d(on)}$	Turn - On Delay Time		7	24	nS	$V_{DD}=300V, I_D=1.1A$ $R_G=25 \Omega$ *
t_r	Rise Time		21	52	nS	
$t_{d(off)}$	Turn - Off Delay Time		13	36	nS	
t_f	Fall Time		27	64	nS	$V_{DS}=480V, I_D=1.1A$ $V_{GS}=10V$ *
Q_g	Total Gate Charge		4.8	6.2	nC	
Q_{gs}	Gate-Source Charge		0.7		nC	
Q_{gd}	Gate-Drain Charge		2.7		nC	
I_s	Continuous Source Current			1	A	
V_{SD}	Diode Forward Voltage			1.4	V	$I_s=0.5A, V_{GS}=0$
$R_{th(j-c)}$	Thermal Resistance , Junction-to-Case			4.53	/W	

*Pulse Test : Pulse Width 300 μs , Duty Cycle 2%

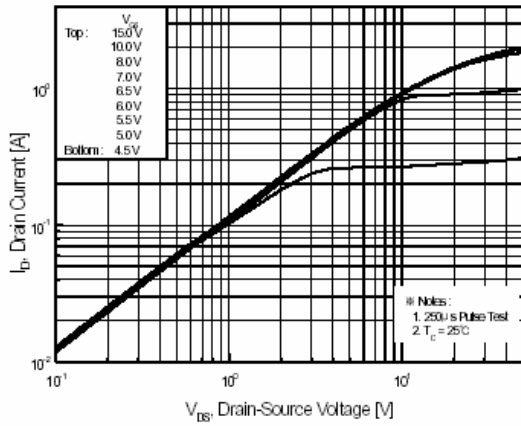

Figure 1. On-Region Characteristics

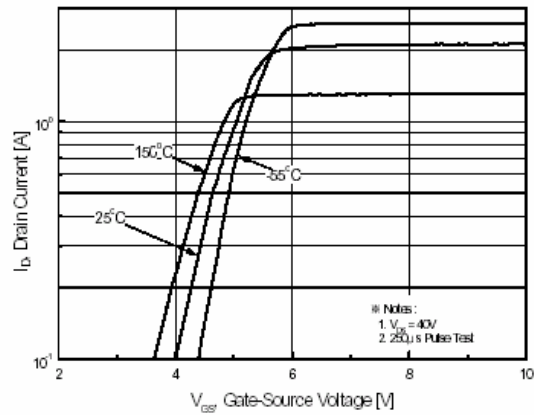

Figure 2. Transfer Characteristics

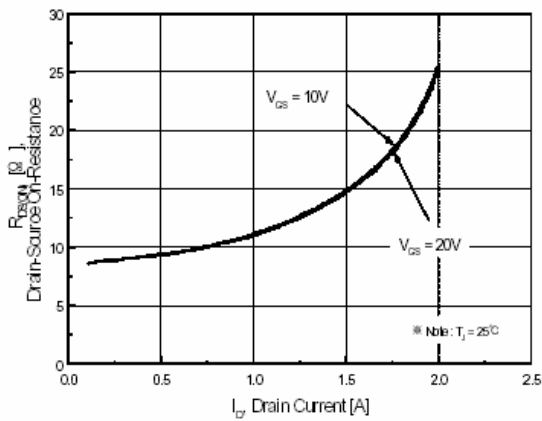

Figure 3. On-Resistance Variation vs Drain Current and Gate Voltage

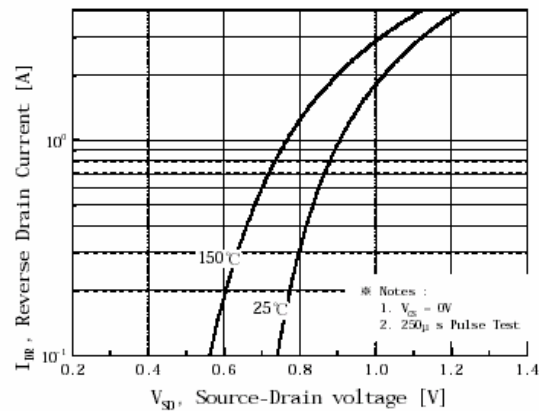

Figure 4. Body Diode Forward Voltage Variation with Source Current and Temperature

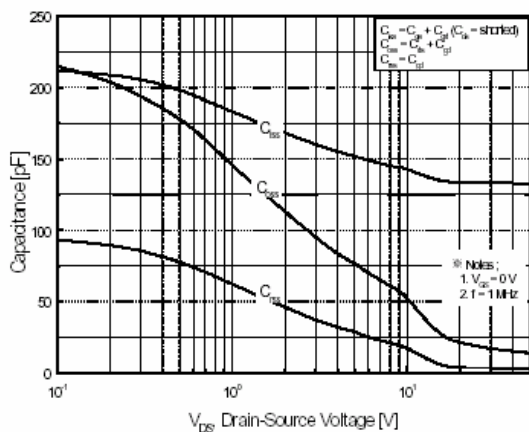

Figure 5. Capacitance Characteristics

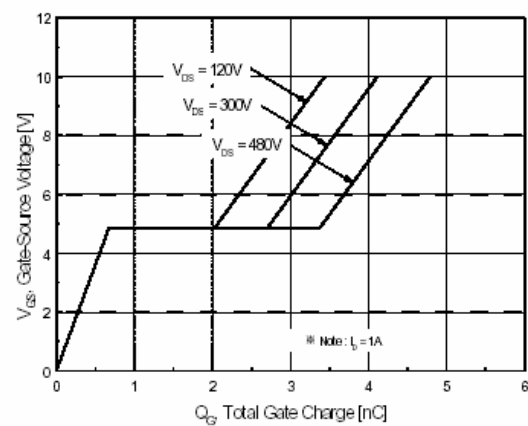

Figure 6. Gate Charge Characteristics

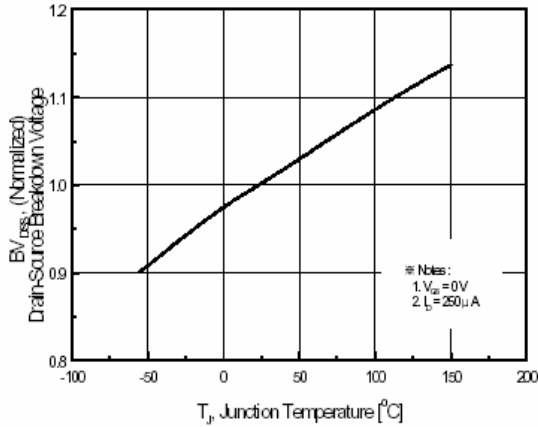

Figure 7. Breakdown Voltage Variation vs Temperature

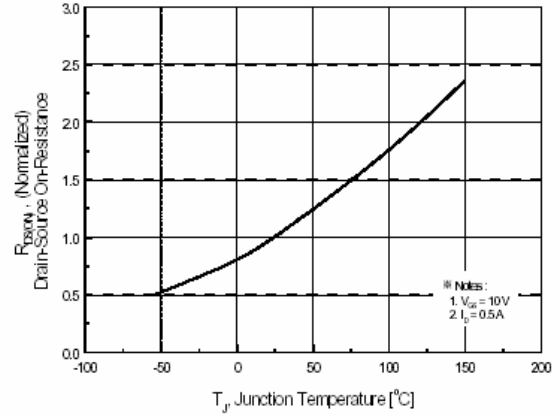

Figure 8. On-Resistance Variation vs Temperature

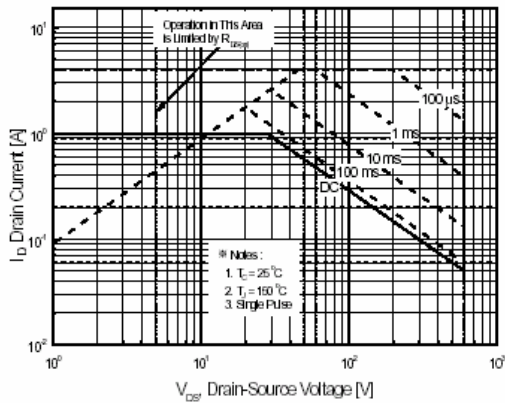

Figure 9. Maximum Safe Operating Area

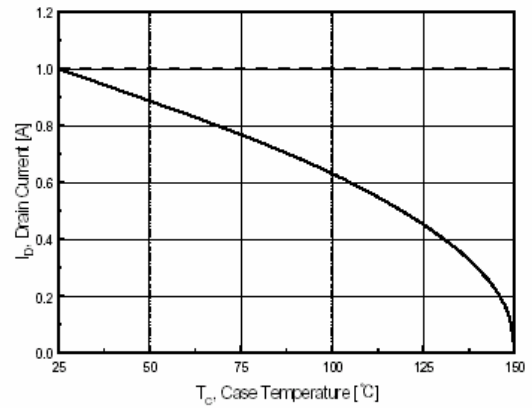

Figure 10. Maximum Drain Current vs Case Temperature

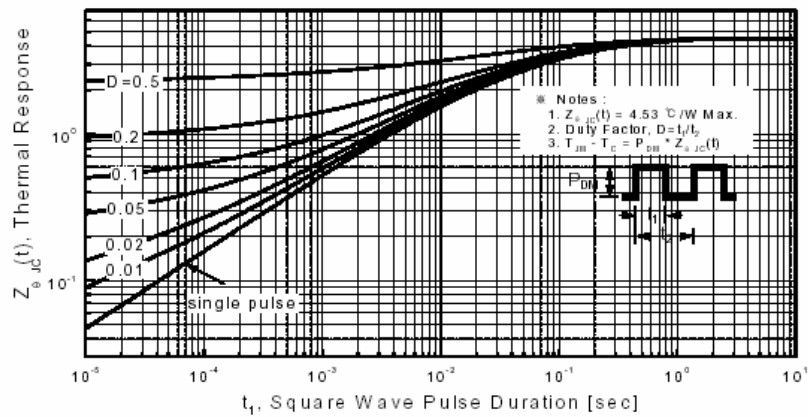
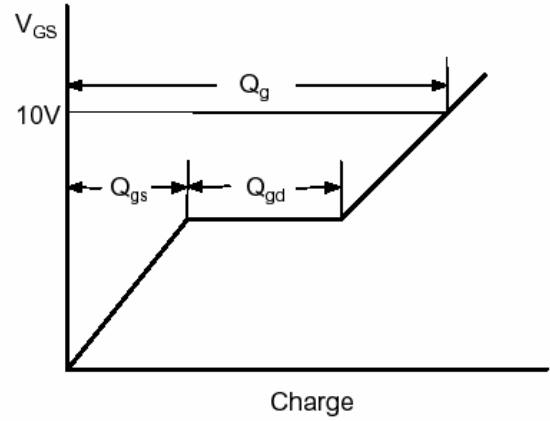
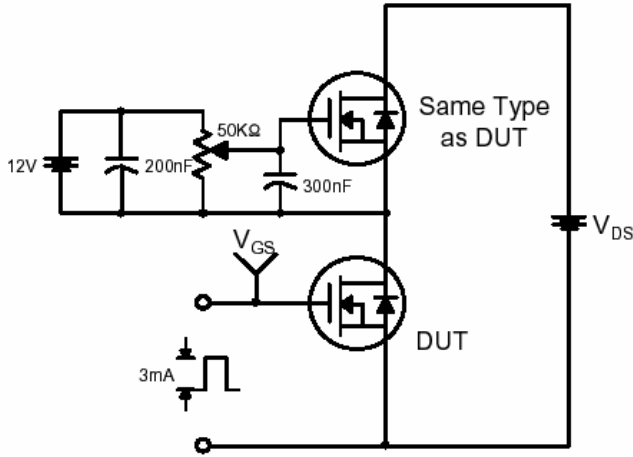

Figure 11. Transient Thermal Response Curve



Gate Charge Test Circuit & Waveform



Resistive Switching Test Circuit & Waveforms

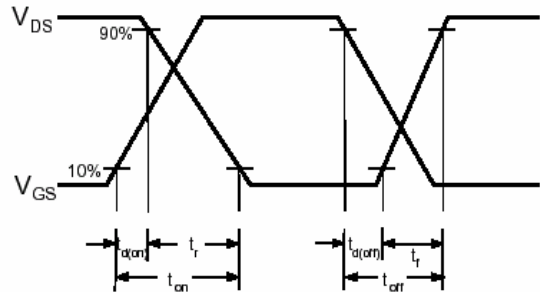
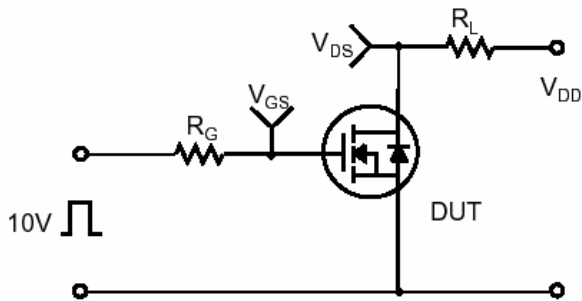

Unclamped Inductive Switching Test Circuit & Waveforms

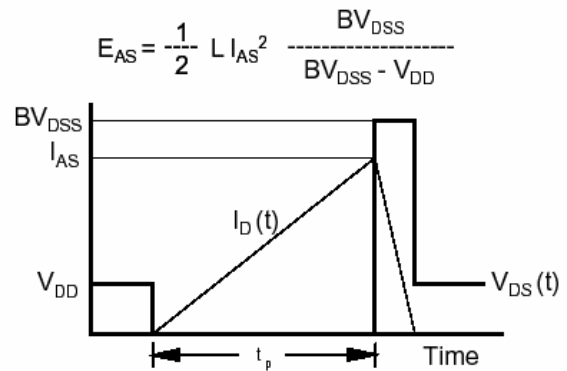
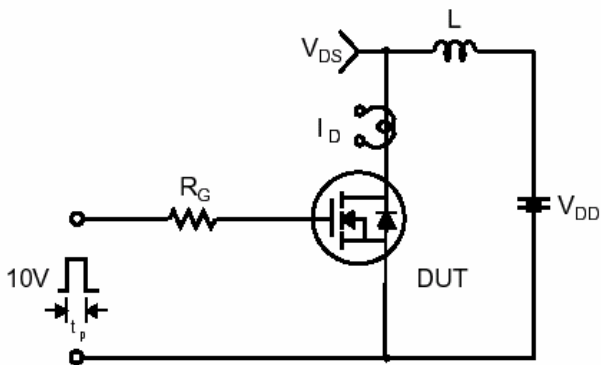



Peak Diode Recovery dv/dt Test Circuit & Waveforms

