

Single Relay Driver IC

Description

This ASIC provides up to 350mA of drive current for driving a relay. On-chip diagnostic features include open and short circuit detection in the on state, duty cycle current limit control, and thermal shutdown. Faults are reported on the $\overline{\text{Fault}}$

lead. $\overline{\text{Fault}}$ is an active-low output. An on-chip zener provides protection from flyback pulses from the relay. Internal pull-down circuitry is provided to ensure the output pin turns off when the Control pin is floating.

Features

- **Fault Detection**
 - Open Circuit
 - Short Circuit
 - Overtemperature
- **On-Chip Flyback Protection**
- **Low Standby Current**

Absolute Maximum Ratings

Storage Temperature -65°C to 150°C
 V_{CC} , $\overline{\text{Fault}}$, Control -0.5V to 6V
 ESD Capability (Human Body Model) 2kV
 Peak Transient Voltage (output off mode, output pin only)
 (26V load Dump @ 14V V_{BAT}) 40V
 Lead Temperature Soldering
 Reflow (SMD styles only) 60 sec. max above 183°C, 230°C peak

Block Diagram

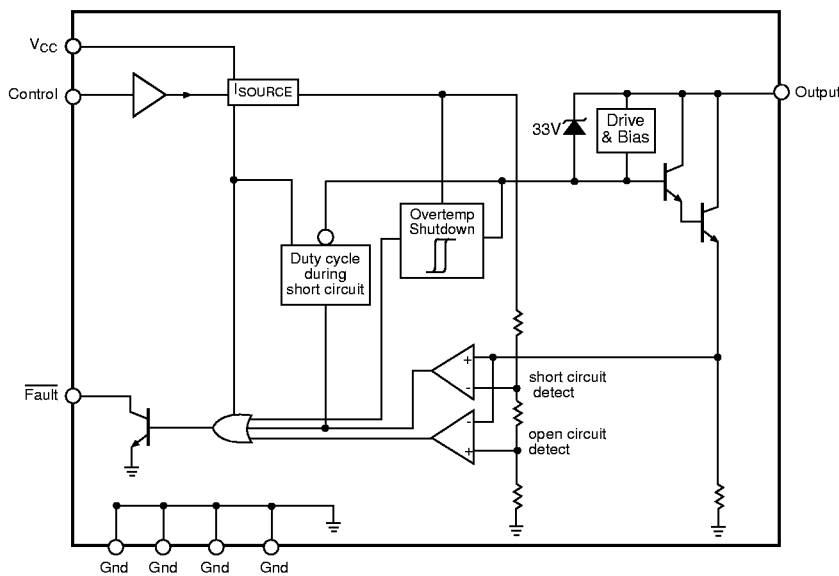

Package Option

8 Lead SO
(internally fused leads)

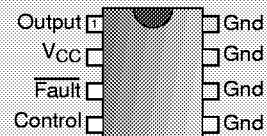

Cherry Semiconductor Corporation
 2000 South County Trail, East Greenwich, RI 02818
 Tel: (401)885-3600 Fax: (401)885-5786
 Email: info@cherry-semi.com
 Web Site: www.cherry-semi.com

Electrical Characteristics: $4.75V \leq V_{CC} \leq 5.25V$, $-40^{\circ}C \leq T_A \leq 85^{\circ}C$, $-40^{\circ}C \leq T_J \leq 150^{\circ}C$

PARAMETER	TEST CONDITIONS	MIN	TYP	MAX	UNIT
■ Supply Requirements					
V_{CC} Quiescent Current	Output ON		3	6	mA
V_{CC} Quiescent Current	Output OFF		70	250	μA
■ Output					
Leakage Current	$V_{BAT} = 14V$		0	100	μA
Saturation Voltage	$I_{OUTPUT} = 350mA$		1.1	1.5	V
	$I_{OUTPUT} = 180mA$		0.9	1.3	V
V_{CLAMP}	$V_{CC} < 4.5V$, $I_{OUTPUT} = 180mA$	29	33	36	V
■ Current Sense					
Short Circuit Current		350	500	650	mA
Open Circuit Current	Output in the ON state	20	40	60	mA
■ Control - Input					
Input Voltage	Logic = High	2.0			V
	Logic = Low			0.8	V
Input Current	Control = V_{CC}		40	80	μA
■ Fault Output - (Open Collector)					
Output Low Voltage	$I_{FAULT} = 250\mu A$ (sink)		0.24	0.40	V
■ Overtemperature Shutdown					
T_J Output Disable Threshold	(Guaranteed by Design)	150	180		$^{\circ}C$
T_J Hysteresis	(Guaranteed by Design)	5			$^{\circ}C$

Package Pin Description

PACKAGE PIN #	PIN SYMBOL	FUNCTION
8 Lead SO (Internally Fused Leads)		
1	Output	Open collector output.
2	V_{CC}	5V regulated supply input.
3	Fault	Open collector diagnostic output low during open load, short circuit and overtemperature conditions.
4	Control	TTL compatible input. A high on this pin turns the output on.
5, 6, 7, 8	Ground	Signal ground.

Circuit Description

CS1107

The CS1107 relay driver IC provides up to 350mA of drive current in a low-side configuration. The Output driver pin is controlled through the TTL compatible Control input pin. A high condition on the Control pin turns the output pin on.

The $\overline{\text{Fault}}$ pin reports short circuit, open circuit, and overtemperature conditions on the IC. If a fault is present, the open collector output $\overline{\text{Fault}}$ pin will be low. Typical numbers for faults are: exceeding 500mA of drive current will report a short circuit. Less than 40mA (typical) will report an open circuit. A temperature fault will be reported when the die temperature exceeds 180°C (typical). Faults

are only reported when the Control pin is high, due to the low quiescent current when the Control pin is low and the output device is turned off.

Overcurrent protection is provided by duty cycle control. When the Output current exceeds the current limit threshold, the output enters duty cycle mode to reduce power dissipation of the IC to a safe level. The higher the threshold is exceeded the lower the duty cycle becomes.

A 33V on-chip zener diode on the Output pin protects the device from flyback pulses when a relay is turned off. The saturation voltage of this pin will not exceed 1.5V at 350mA.

Applications Diagram

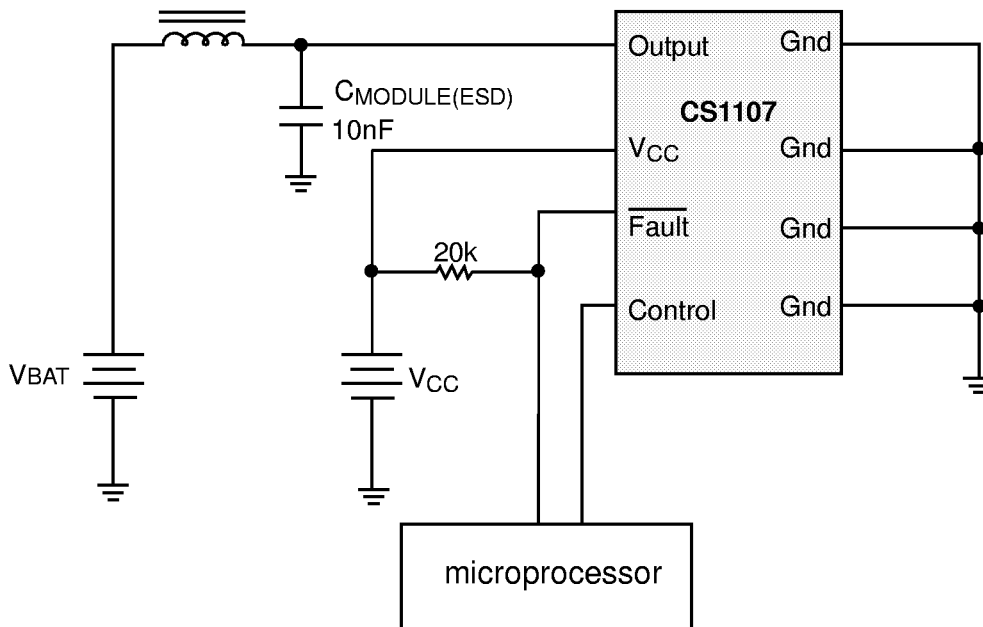

Package Specification

PACKAGE DIMENSIONS IN mm (INCHES)

Lead Count	D			
	Metric		English	
	Max	Min	Max	Min
8 Lead SO	5.00	4.80	.197	.189

PACKAGE THERMAL DATA

Thermal Data		8 Lead SO (internally fused leads)	
$R_{\theta JC}$	typ	25	$^{\circ}C/W$
$R_{\theta JA}$	typ	110	$^{\circ}C/W$

Surface Mount Narrow Body (D); 150 mil wide

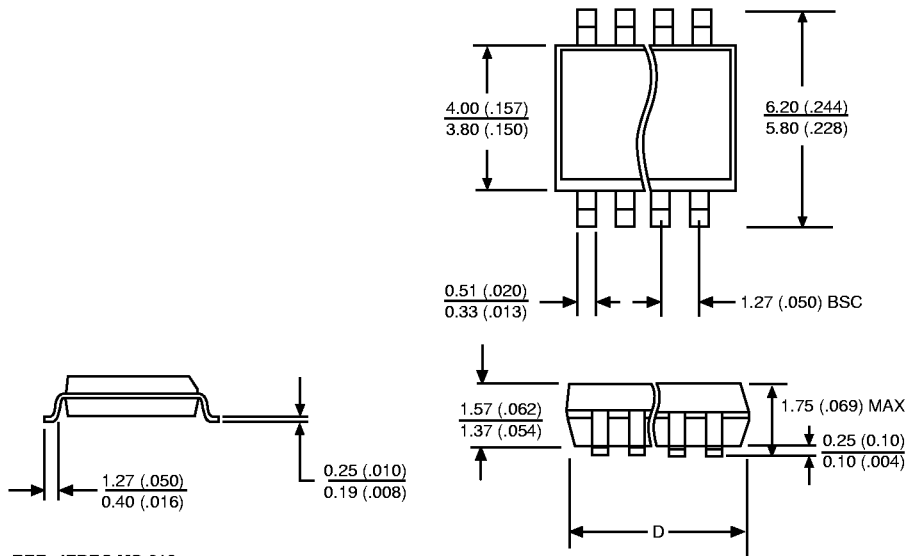

REF: JEDEC MS-012

Ordering Information

Part Number	Description
CS1107D8	8 Lead SO (internally fused leads)
CS1107DR8	8 Lead SO (internally fused leads) (tape & reel)

Cherry Semiconductor Corporation reserves the right to make changes to the specifications without notice. Please contact Cherry Semiconductor Corporation for the latest available information.