

512Mb C-die NOR FLASH

9x11, 64FBGA, 32M x16, Muxed Burst, Multi Bank SLC
1.7V ~ 1.95V

datasheet

SAMSUNG ELECTRONICS RESERVES THE RIGHT TO CHANGE PRODUCTS, INFORMATION AND SPECIFICATIONS WITHOUT NOTICE.

Products and specifications discussed herein are for reference purposes only. All information discussed herein is provided on an "AS IS" basis, without warranties of any kind.

This document and all information discussed herein remain the sole and exclusive property of Samsung Electronics. No license of any patent, copyright, mask work, trademark or any other intellectual property right is granted by one party to the other party under this document, by implication, estoppel or otherwise.

Samsung products are not intended for use in life support, critical care, medical, safety equipment, or similar applications where product failure could result in loss of life or personal or physical harm, or any military or defense application, or any governmental procurement to which special terms or provisions may apply.

For updates or additional information about Samsung products, contact your nearest Samsung office.

All brand names, trademarks and registered trademarks belong to their respective owners.

© 2010 Samsung Electronics Co., Ltd. All rights reserved.

Revision History

<u>Revision No.</u>	<u>History</u>	<u>Draft Date</u>	<u>Remark</u>	<u>Editor</u>
0.0	- First version for target specification.	Mar. 31, 2010	Target	-
1.0	- Specification is finalized.	May. 03, 2010	Final	-
1.1	- Added "CLK "HIGH" should be prohibited in asynchronous read mode start (From CE LOW)" in Asynchronous read operation.	Sep. 06, 2010	Final	-

[512Mb C-die NOR FLASH 1](#)

1.0 FEATURES.....	5
2.0 GENERAL DESCRIPTION	5
3.0 PIN DESCRIPTION	5
4.0 64Ball FBGA TOP VIEW (BALL DOWN)	6
5.0 FUNCTIONAL BLOCK DIAGRAM	7
6.0 ORDERING INFORMATION	8
7.0 PRODUCT INTRODUCTION.....	11
8.0 COMMAND DEFINITIONS	12
9.0 DEVICE OPERATION	14
9.1 Read Mode	14
9.1.1 Asynchronous Read Mode.....	14
9.1.2 Synchronous (Burst) Read Mode.....	14
9.1.2.1 Continuous Linear Burst Read.....	14
9.2 Programmable Wait State	15
9.3 Handshaking.....	15
9.4 Set Burst Mode Configuration Register	15
9.4.1 Programmable Wait State Configuration.....	15
9.4.2 Burst Read Mode Setting	15
9.4.3 RDY Configuration	16
9.5 Output Driver Setting	17
9.6 Autoselect Mode	17
9.7 Standby Mode	17
9.8 Automatic Sleep Mode	17
9.9 Output Disable Mode.....	17
9.10 Block Protection & Unprotection.....	18
9.11 Hardware Reset.....	18
9.12 Software Reset	18
9.13 Program.....	18
9.14 Accelerated Program.....	18
9.15 Write Buffer Programming	19
9.16 Accelerated Write Buffer Programming	19
9.17 Chip Erase	19
9.18 Block Erase	20
9.19 Blank check	20
9.20 Unlock Bypass.....	20
9.21 Erase Suspend / Resume.....	20
9.22 Program Suspend / Resume	21
9.23 Read While Write Operation.....	21
9.24 OTP Block Region	21
9.25 Low VCC Write Inhibit	21
9.26 Write Pulse "Glitch" Protection	21
9.27 Logical Inhibit.....	21
10.0 FLASH MEMORY STATUS FLAGS	22
11.0 Deep Power Down	24
12.0 Common Flash Memory Interface.....	25
13.0 ABSOLUTE MAXIMUM RATINGS	27
14.0 RECOMMENDED OPERATING CONDITIONS	28
15.0 DC CHARACTERISTICS.....	28
16.0 VCC POWER-UP.....	29
17.0 CAPACITANCE(TA = 25 °C, VCC = 1.8V, f = 1.0MHz).....	29
18.0 AC TEST CONDITION.....	30
19.0 AC CHARACTERISTICS	30
19.1 Synchronous/Burst Read.....	30
19.2 Asynchronous Read	34

19.3 Hardware Reset(RESET) 36
19.4 Erase/Program Operation..... 37
19.5 Erase/Program Performance..... 38
20.0 Crossing of First Word Boundary in Burst Read Mode 45



512M Bit (32M x16) Muxed Burst / Multi Bank SLC NOR Flash Memory

1.0 FEATURES

- Single Voltage, 1.7V to 1.95V for Read and Write operations
- Organization
 - 33,554,432 x 16 bit (Word Mode Only)
- Multiplexed Data and Address for reduction of interconnections
 - A/DQ0 ~ A/DQ15
- Read While Program/Erase Operation
- Multiple Bank Architecture
 - 16 Banks (32Mb Partition)
- OTP Block : Extra 512-Word block
- Read Access Time (@ $C_L=30pF$)
 - Asynchronous Random Access Time : 100ns
 - Synchronous Random Access Time : 95ns
 - Burst Access Time :
 - 11ns (66MHz) / 9ns (83MHz) / 7ns (108MHz) / 6ns (133MHz)
- Burst Length :
 - Continuous Linear Burst
 - Linear Burst : 8-word & 16-word with Wrap
- Block Architecture
 - Uniform block part (K8S(10/11/12/13)15EZC) :
 - Five hundred twelve 64Kword blocks
 - Boot block part (K8S(10/11/12/13)15ET(B)C) :
 - Four 16Kword blocks and five hundred eleven 64Kword blocks (Bank 0 contains four 16 Kword blocks and thirty-one 64Kword blocks, Bank 1 ~ Bank 15 contain four hundred eighty 64Kword blocks)
- Reduce program time using the V_{PP}
- Support 512-word Buffer Program
- Power Consumption (Typical value, $C_L=30pF$)
 - Synchronous Read Current : 35mA at 133MHz
 - Program/Erase Current : 25mA
 - Read While Program/Erase Current : 45mA
 - Standby Mode/Auto Sleep Mode : 30uA
- Block Protection/Unprotection
 - Using the software command sequence
 - Last two boot blocks are protected by $WP=V_{IL}$ (Boot block part : K8S(10/11/12/13)15ET(B)C)
 - Last one block (BA511) is protected by $WP=V_{IL}$ (Uniform block part : K8S(10/11/12/13)15EZC)
 - All blocks are protected by $V_{PP}=V_{IL}$
- Handshaking Feature
 - Provides host system with minimum latency by monitoring RDY
- Erase Suspend/Resume
- Program Suspend/Resume
- Unlock Bypass Program/Erase
- Blank Check Feature
- Hardware Reset (\overline{RESET})
- Deep Power Down Mode
- Data Polling and Toggle Bits
 - Provides a software method of detecting the status of program or erase completion
- Endurance
 - 100K Program/Erase cycles
- Extended Temperature : -25°C ~ 85°C
- Support Common Flash Memory Interface
- Low V_{cc} Write Inhibit
- Output Driver Control by Configuration Register
- Package : 64Ball FBGA type (9mm x 11mm), 0.5mm ball pitch
1.0mm(Max.)Thickness

2.0 GENERAL DESCRIPTION

The K8S(10/11/12/13)15E featuring single 1.8V power supply is a 512Mbit Muxed Burst Multi Bank Flash Memory organized as 32Mx16. The memory architecture of the device is designed to divide its memory arrays into 512blocks(Uniform block part)/515 blocks (Boot block part) with independent hardware protection. This block architecture provides highly flexible erase and program capability. The K8S(10/11/12/13)15E NOR Flash consists of sixteen banks. This device is capable of reading data from one bank while programming or erasing in the other bank. Regarding read access time, the K8S10/1215E provides an 11ns burst access time and an 95ns initial access time at 66MHz. At 83MHz, the K8S10/1215E provides an 9ns burst access time and an 95ns initial access time. At 108MHz, the K8S11/1315E provides an 7ns burst access time and an 95ns initial access time. At 133MHz, the K8S11/1315E provides an 6ns burst access time and an 95ns initial access time. The device performs a program operation in units of 16 bits (Word) and erases in units of a block. Single or multiple blocks can be erased. The block erase operation is completed within typically 0.6sec. The device requires 25mA as program/erase current in the extended temperature ranges.

The K8S(10/11/12/13)15E NOR Flash Memory is created by using Samsung's advanced CMOS process technology.

3.0 PIN DESCRIPTION

Pin Name	Pin Function
A16 - A24	Address Inputs
A/DQ0 - A/DQ15	Multiplexed Address/Data input/output
\overline{CE}	Chip Enable
\overline{OE}	Output Enable
\overline{RESET}	Hardware Reset
V_{PP}	Accelerates Programming
\overline{WE}	Write Enable
\overline{WP}	Hardware Write Protection Input
CLK	Clock
RDY	Ready Output
\overline{AVD}	Address Valid Input
DPD	Deep Power Down
V_{cc}	Power Supply
V_{ss}	Ground

4.0 64Ball FBGA TOP VIEW (BALL DOWN)

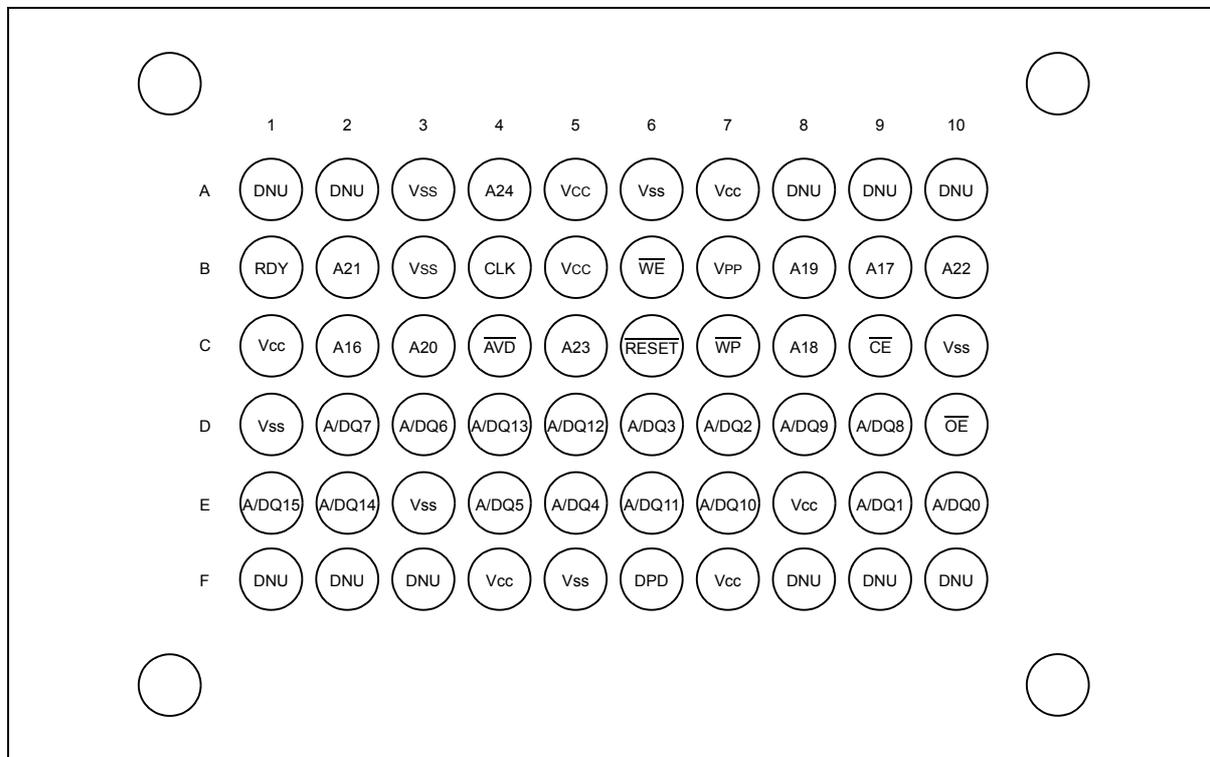

5.0 FUNCTIONAL BLOCK DIAGRAM

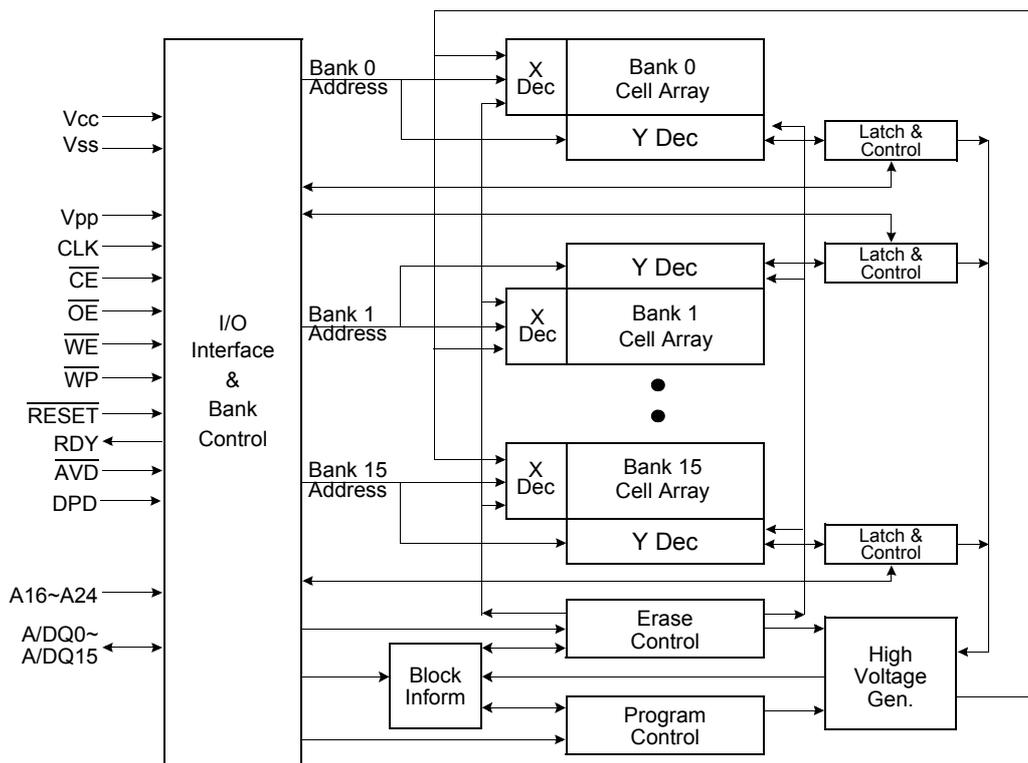

6.0 ORDERING INFORMATION

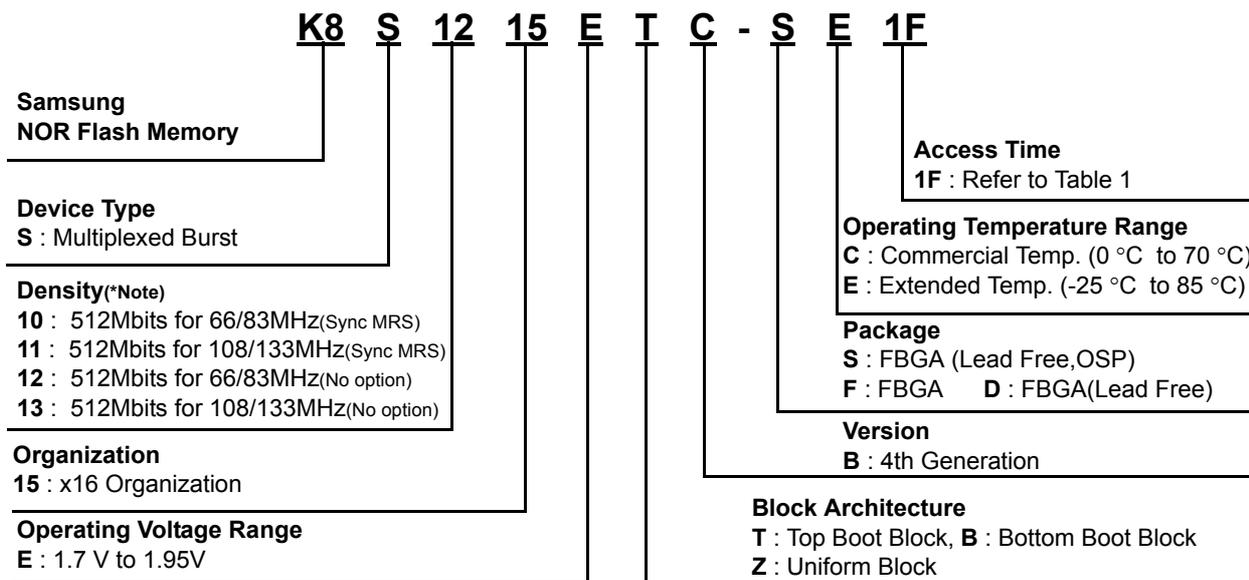

NOTE
Density : (1) 10 : 512Mb for 66/83Mhz with the Sync MRS option (Extended Configuration Register)
(2) 11 : 512Mb for 108/133Mhz with the Sync MRS option (Extended Configuration Register)
(3) 12 : 512Mb for 66/83Mhz with no option
(4) 13 : 512Mb for 108/133Mhz with no option

[Table 1] PRODUCT LINE-UP

K8S(10/11/12/13)15E						
	Mode	Speed Option	1C (66MHz)	1D (83MHz)	1E (108MHz)	1F (133MHz)
V _{CC} =1.7V-1.95V	Synchronous/Burst	Max. Initial Access Time (t _{IA} , ns)	95	95	95	95
		Max. Burst Access Time (t _{BA} , ns)	11	9	7	6
	Asynchronous	Max. Access Time (t _{AA} , ns)	100	100	100	100
		Max. \overline{CE} Access Time (t _{CE} , ns)	100	100	100	100
		Max. \overline{OE} Access Time (t _{OE} , ns)	15	15	15	15

[Table 2] PRODUCT Classification

Speed/Boot Option	Top	Bottom	Uniform
512Mb for 66/83MHz (Sync MRS option)	K8S1015ETC	K8S1015EBC	K8S1015EZC
512Mb for 108/133MHz (Sync MRS option)	K8S1115ETC	K8S1115EBC	K8S1115EZC
512Mb for 66/83MHz	K8S1215ETC	K8S1215EBC	K8S1215EZC
512Mb for 108/133MHz	K8S1315ETC	K8S1315EBC	K8S1315EZC

[Table 3] K8S(10/11/12/13)15E DEVICE BANK DIVISIONS

Bank 0 ~ Bank 15	
Type	Block Sizes
512Mbit (Boot block part)	Four 16Kword blocks and five hundred eleven 64Kword blocks
512Mbit (Uniform block part)	Five hundred twelve 64Kword blocks

[Table 4] K8S(10/11/12/13)15E ZC DEVICE BANK DIVISIONS (Uniform block)

Bank	Bank size	Quantity of Blocks	Block Size
0	32Mb	32	64 Kwords
1	32Mb	32	64 Kwords
2	32Mb	32	64 Kwords
3	32Mb	32	64 Kwords
4	32Mb	32	64 Kwords
5	32Mb	32	64 Kwords
6	32Mb	32	64 Kwords
7	32Mb	32	64 Kwords
8	32Mb	32	64 Kwords
9	32Mb	32	64 Kwords
10	32Mb	32	64 Kwords
11	32Mb	32	64 Kwords
12	32Mb	32	64 Kwords
13	32Mb	32	64 Kwords
14	32Mb	32	64 Kwords
15	32Mb	32	64 Kwords

[Table 5] K8S(10/11/12/13)15ETC DEVICE BANK DIVISIONS (Top Boot block)

Bank	Bank size	Quantity of Blocks	Block Size
0	32Mb	4	16 Kwords
		31	64 Kwords
1	32Mb	32	64 Kwords
2	32Mb	32	64 Kwords
3	32Mb	32	64 Kwords
4	32Mb	32	64 Kwords
5	32Mb	32	64 Kwords
6	32Mb	32	64 Kwords
7	32Mb	32	64 Kwords
8	32Mb	32	64 Kwords
9	32Mb	32	64 Kwords
10	32Mb	32	64 Kwords
11	32Mb	32	64 Kwords
12	32Mb	32	64 Kwords
13	32Mb	32	64 Kwords
14	32Mb	32	64 Kwords
15	32Mb	32	64 Kwords

[Table 6] K8S(10/11/12/13)15EBC DEVICE BANK DIVISIONS (Bottom Boot block)

Bank	Bank size	Quantity of Blocks	Block Size
15	32Mb	32	64 Kwords
14	32Mb	32	64 Kwords
13	32Mb	32	64 Kwords
12	32Mb	32	64 Kwords
11	32Mb	32	64 Kwords
10	32Mb	32	64 Kwords
9	32Mb	32	64 Kwords
8	32Mb	32	64 Kwords
7	32Mb	32	64 Kwords
6	32Mb	32	64 Kwords
5	32Mb	32	64 Kwords
4	32Mb	32	64 Kwords
3	32Mb	32	64 Kwords
2	32Mb	32	64 Kwords
1	32Mb	32	64 Kwords
0	32Mb	31	64 Kwords
		4	16 Kwords

7.0 PRODUCT INTRODUCTION

The K8S(10/11/12/13)15E is an 512Mbit (536,870,912 bits) NOR-type Burst Flash memory. The device features 1.8V single voltage power supply operating within the range of 1.7V to 1.95V. The device is programmed by using the Channel Hot Electron (CHE) injection mechanism which is used to program EPROMs. The device is erased electrically by using Fowler-Nordheim tunneling mechanism. To provide highly flexible erase and program capability, the device adapts a block memory architecture that divides its memory array into 512 blocks (64-Kword x 512 blocks, Uniform block part) / 515 blocks (16-Kword x 4 + 64-Kword x 511, Boot block part). Programming is done in units of 16 bits (Word). All bits of data in one or multiple blocks can be erased when the device executes the erase operation. To prevent the device from accidental erasing or over-writing the programmed data, 512 / 515 memory blocks can be hardware protected. Regarding read access time, at 66MHz, the K8S10/1215E provides a burst access of 11ns with initial access times of 95ns at 30pF. At 83MHz, the K8S10/1215E provides a burst access of 9ns with initial access times of 95ns at 30pF. At 108MHz, the K8S11/1315E provides a burst access of 7ns with initial access times of 95ns at 30pF. At 133MHz, the K8S11/1315E provides a burst access of 6ns with initial access times of 95ns at 30pF. The command set of K8S(10/11/12/13)15E is compatible with standard Flash devices. The device uses Chip Enable (\overline{CE}), Write Enable (\overline{WE}), Address Valid(AVD) and Output Enable (\overline{OE}) to control asynchronous read and write operation. For burst operations, the device additionally requires Ready (RDY) and Clock (CLK). Device operations are executed by selective command codes. The command codes to be combined with addresses and data are sequentially written to the command registers using microprocessor write timing. The command codes serve as inputs to an internal state machine which controls the program/erase circuitry. Register contents also internally latch addresses and data necessary to execute the program and erase operations. The K8S(10/11/12/13)15E is implemented with Internal Program/Erase Routines to execute the program/erase operations. The Internal Program/Erase Routines are invoked by program/erase command sequences. The Internal Program Routine automatically programs and verifies data at specified addresses. The Internal Erase Routine automatically pre-programs the memory cell which is not programmed and then executes the erase operation. The K8S(10/11/12/13)15E has means to indicate the status of completion of program/erase operations. The status can be indicated via Data polling of DQ7, or the Toggle bit (DQ6). Once the operations have been completed, the device automatically resets itself to the read mode. The device requires only 35mA as burst and asynchronous mode read current and 25mA for Buffer program/erase operations.

[Table 7] Device Bus Operations

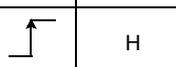
Operation	\overline{CE}	\overline{OE}	\overline{WE}	A16-24	A/DQ0-15	\overline{RESET}	CLK	\overline{AVD}
Asynchronous Read Operation	L	L	H	Add In	Add In/Dout	H	L	
Write	L	H	L	Add In	Add In / Din	H	L	
Standby	H	X	X	X	High-Z	H	X	X
Hardware Reset	X	X	X	X	High-Z	L	X	X
Load Initial Burst Address	L	H	H	Add In	Add In	H		
Burst Read Operation	L	L	H	X	Burst DOUT	H		
Terminate Burst Read Cycle	H	X	X	X	High-Z	H	X	X
Terminate Burst Read Cycle via \overline{RESET}	X	X	X	X	High-Z	L	X	X
Terminate Current Burst Read Cycle and Start New Burst Read Cycle	L	H	H	Add In	Add In	H		

NOTE : L=VIL (Low), H=VIH (High), X=Don't Care.

8.0 COMMAND DEFINITIONS

The K8S(10/11/12/13)15E operates by selecting and executing its operational modes. Each operational mode has its own command set. In order to select a certain mode, a proper command with specific address and data sequences must be written into the command register. Writing incorrect information which include address and data or writing an improper command will reset the device to the read mode. The defined valid register command sequences are stated in Table 8.

[Table 8] Command Sequences

Command Definitions		Cycle	1st Cycle	2nd Cycle	3rd Cycle	4th Cycle	5th Cycle	6th Cycle
Asynchronous Read	Add	1	RA					
	Data		RD					
Reset ^(5),20)	Add	1	XXXH					
	Data		F0H					
Autoselect Manufacturer ID ⁽⁶⁾	Add	4	555H	2AAH	(DA)555H	(DA)X00H		
	Data		AAH	55H	90H	ECH		
Autoselect Device ID ⁽⁶⁾	Add	4	555H	2AAH	(DA)555H	(DA)X01H		
	Data		AAH	55H	90H	NOTE6		
Autoselect Block Protection Verify ⁽⁷⁾	Add	4	555H	2AAH	(BA)555H	(BA)X02H		
	Data		AAH	55H	90H	00H/01H		
Autoselect Handshaking ^(6), 8)	Add	4	555H	2AAH	(DA)555H	(DA)X03H		
	Data		AAH	55H	90H	0H/1H		
Program	Add	4	555H	2AAH	555H	PA		
	Data		AAH	55H	A0H	PD		
Unlock Bypass	Add	3	555H	2AAH	555H			
	Data		AAH	55H	20H			
Unlock Bypass Program ⁽⁹⁾	Add	2	XXX	PA				
	Data		A0H	PD				
Unlock Bypass Block Erase ⁽⁹⁾	Add	2	XXX	BA				
	Data		80H	30H				
Unlock Bypass Chip Erase ⁽⁹⁾	Add	2	XXXH	XXXH				
	Data		80H	10H				
Unlock Bypass Reset	Add	2	XXXH	XXXH				
	Data		90H	00H				
Chip Erase	Add	6	555H	2AAH	555H	555H	2AAH	555H
	Data		AAH	55H	80H	AAH	55H	10H
Block Erase	Add	6	555H	2AAH	555H	555H	2AAH	BA
	Data		AAH	55H	80H	AAH	55H	30H
Erase Suspend ⁽¹⁰⁾	Add	1	(DA)XXXH					
	Data		B0H					
Erase Resume ⁽¹¹⁾	Add	1	(DA)XXXH					
	Data		30H					
Program Suspend ⁽¹²⁾	Add	1	(DA)XXXH					
	Data		B0H					
Program Resume ⁽¹¹⁾	Add	1	(DA)XXXH					
	Data		30H					
Block Protection/Unprotection ⁽¹³⁾	Add	3	XXX	XXX	ABP			
	Data		60H	60H	60H			
CFI Query ⁽¹⁴⁾	Add	1	(DA)X55H					
	Data		98H					
Blank check	Add	4	555H	2AAH	BA	BA		
	Data		AAH	55H	BCH	D0H		

Command Definitions		Cycle	1st Cycle	2nd Cycle	3rd Cycle	4th Cycle	5th Cycle	6th Cycle
Write to Buffer ¹⁵⁾	Add	3	555H	2AAH	BA	BA	PA	WBL
	Data		AAH	55H	25H	WC	PD	PD
Program buffer to Flash ¹⁵⁾	Add	1	BA					
	Data		29H					
Write to Buffer Abort Reset ^{16),20)}	Add	3	555H	2AAH	XXX			
	Data		AAH	55H	F0H			
Set Burst Mode Configuration Register ^{17),18)}	Add	3	555H	2AAH	NOTE 18			
	Data		AAH	55H	C0H			
Set Extended Configuration Register ^{17),19)}	Add	3	555H	2AAH	NOTE 19			
	Data		AAH	55H	C5H			
Enter OTP Block Region	Add	3	555H	2AAH	XXX			
	Data		AAH	55H	70H			
Exit OTP Block Region	Add	4	555H	2AAH	555H	XXX		
	Data		AAH	55H	75H	00H		

NOTE :

- 1) RA : Read Address, PA : Program Address, RD : Read Data, PD : Program Data, BA : Block Address (A24 ~ A14), DA : Bank Address (A24 ~ A21), ABP : Address of the block to be protected or unprotected, DI : Die revision ID, CR : Configuration Register Setting, WBL : Write Buffer Location, WC : Word Count
- 2) The 4th cycle data of autoselect mode and RD are output data. The others are input data.
- 3) Data bits DQ15–DQ8 are don't care in command sequences, except for RD, PD, WC and Device ID.
- 4) Unless otherwise noted, address bits A24–A11 are don't cares.
- 5) The reset command is required to return to read mode.
If a bank entered the autoselect mode during the erase suspend mode, writing the reset command returns that bank to the erase suspend mode.
If a bank entered the autoselect mode during the program suspend mode, writing the reset command returns that bank to the program suspend mode.
If DQ5 goes high during the program or erase operation, writing the reset command returns that bank to read mode or erase suspend mode if that bank was in erase suspend mode.
- 6) The 3rd and 4th cycle bank address of autoselect mode must be same.
Device ID Data : Top(3010H), Bottom(3011H), Uniform(3012H)
- 7) Normal Block Protection Verify : 00H for an unprotected block and 01H for a protected block.
OTP Block Protect verify (with OTP Block Address after Entering OTP Block) : 00H for unlocked, and 01H for locked.
- 8) 0H for handshaking, 1H for non-handshaking
- 9) The unlock bypass command sequence is required prior to this command sequence.
- 10) The system may read and program in non-erasing blocks when in the erase suspend mode.
The system may enter the autoselect mode when in the erase suspend mode.
The erase suspend command is valid only during a block erase operation, and requires the bank address.
- 11) The erase/program resume command is valid only during the erase/program suspend mode, and requires the bank address.
- 12) This mode is used only to enable Data Read by suspending the Program operation.
- 13) Set ABP (Address of the block to be protected or unprotected) as either A6 = VIH, A1 = VIH and A0 = VIL for unprotected or A6 = VIL, A1 = VIH and A0 = VIL for protected.
- 14) Command is valid when the device is in Read mode or Autoselect mode.
- 15) For Buffer Program, Firstly Enter "Write to Buffer" Command sequence and then Enter Block Address and Word Count which is the number of word data will be programmed. Word Count is smaller than the number of data wanted to program by one, Example if 15 words are wanted to program then WC (Word Count) is 14. After Entering Command, Enter PA/PD's (Program Addresses/ Program Data). Finally Enter "Program buffer to Flash" Command sequence, This starts a buffer program operation. This Device supports 512-word Buffer Program.
There is some caution points.
- The number of PA/PD's which are entered must be same to WC+1
- PA's which are entered must be same A24~A9 address bits because Buffer Address is A24~A9 address and decided by PA entered firstly.
- If PA which are entered isn't same Buffer Address, then PA/PD which is entered may be ignored and this buffer programming operation is aborted.
To return to normal operation, hardware reset or "Write to Buffer Abort Reset" command is issued.
- Overwrite for program buffer is also prohibited.
- 16) Command sequence resets device for next command after aborted write-to-buffer operation.
- 17) See "Set Burst Mode Configuration Register" for details.
- 18) On the third cycle, the data should be "C0h", address bits A10-A0 should be 101_0101_0101b, and address bits A21-A11 set the code to be latched.
- 19) On the third cycle, the data should be "C5h", address bits A10-A0 should be 101_0101_0101b, and address bits A21-A11 set the code to be latched.
- 20) After software reset and write to buffer abort reset command, min. 5us recovery time is needed for normal read mode.

9.0 DEVICE OPERATION

The device has inputs/outputs that accept both address and data information. To write a command or command sequence (which includes programming data to the device and erasing blocks of memory), the system must drive $\overline{\text{CLK}}$, $\overline{\text{AVD}}$ and $\overline{\text{CE}}$ to V_{IL} and $\overline{\text{OE}}$ to V_{IH} when providing an address to the device, and drive $\overline{\text{CLK}}$, $\overline{\text{WE}}$ and $\overline{\text{CE}}$ to V_{IL} and $\overline{\text{OE}}$ to V_{IH} when writing commands or data.

The device provides the unlock bypass mode to save its program time for program operation. Unlike the standard program command sequence which is comprised of four bus cycles, only two program cycles are required to program a word in the unlock bypass mode. One block, multiple blocks, or the entire device can be erased. Table 17 indicates the address space that each block occupies. The device's address space is divided into sixteen banks. A "bank address" is the address bits required to uniquely select a bank. Similarly, a "block address" is the address bits required to uniquely select a block. Icc2 in the DC Characteristics table represents the active current specification for the write mode. The AC Characteristics section contains timing specification tables and timing diagrams for write operations.

9.1 Read Mode

The device automatically enters to asynchronous read mode after device power-up. No commands are required to retrieve data in asynchronous mode. After completing an Internal Program/Erase Routine, each bank is ready to read array data. The reset command is required to return a bank to the read (or erase-suspend-read) mode if DQ5 goes high during an active program/erase operation, or if the bank is in the autoselect mode.

(1) K8S1015ET(B)(Z)C : 66/83Mhz with the Sync MRS option (Extended Configuration Register)

(2) K8S1115ET(B)(Z)C : 108/133Mhz with the Sync MRS option (Extended Configuration Register)

The synchronous (burst) mode will automatically start on the rising edge of the $\overline{\text{CLK}}$ input while $\overline{\text{AVD}}$ is held low after Extended Mode Register Setting to $A13=0$, $A12=1$. If several $\overline{\text{CLK}}$ s exist in $\overline{\text{AVD}}$ low, the last rising edge is valid $\overline{\text{CLK}}$.

(3) K8S1215ET(B)(Z)C : 66/83Mhz with no option

(4) K8S1315ET(B)(Z)C : 108/133Mhz with no option

The synchronous (burst) mode will automatically start on the rising edge of the $\overline{\text{CLK}}$ input while $\overline{\text{AVD}}$ is held low. If several $\overline{\text{CLK}}$ s exist in $\overline{\text{AVD}}$ low, the last rising edge is valid $\overline{\text{CLK}}$.

9.1.1. Asynchronous Read Mode

For the asynchronous read mode a valid address should be asserted on $A/\text{DQ0-A}/\text{DQ15}$ and $A16-A24$, while driving $\overline{\text{CLK}}$ and $\overline{\text{AVD}}$ and $\overline{\text{CE}}$ to V_{IL} . $\overline{\text{WE}}$ and $\overline{\text{OE}}$ should remain at V_{IH} . Note that $\overline{\text{CLK}}$ must remain low for asynchronous read mode. The address is latched at the rising edge of $\overline{\text{AVD}}$, and then the system can drive $\overline{\text{OE}}$ to V_{IL} . The data will appear on $A/\text{DQ0-A}/\text{DQ15}$. Since the memory array is divided into sixteen banks, each bank remains enabled for read access until the command register contents are altered.

Address access time (t_{AA}) is equal to the delay from valid addresses to valid output data. The chip enable access time (t_{CE}) is the delay from the falling edge of $\overline{\text{CE}}$ to valid data at the outputs. The output enable access time (t_{OE}) is the delay from the falling edge of $\overline{\text{OE}}$ to valid data at the output. The asynchronous access time is measured from a valid address, falling edge of $\overline{\text{AVD}}$ or falling edge of $\overline{\text{CE}}$ whichever occurs last. To prevent the memory content from spurious altering during power transition, the initial state machine is set for reading array data upon device power-up, or after a hardware reset.

9.1.2. Synchronous (Burst) Read Mode

The device is capable of continuous linear burst operation and linear burst operation of a preset length. For the burst mode, the system should determine how many clock cycles are desired for the initial word (t_{IAA}) of each burst access and what mode of burst operation is desired using "Burst Mode Configuration Register" command sequences. See "Set Burst Mode Configuration" for further details. The status data also can be read by synchronous read mode with a bank address which is programming or erasing. This status data by synchronous read mode can be output and sustained until the system asserts $\overline{\text{CE}}$ high or $\overline{\text{RESET}}$ low or $\overline{\text{AVD}}$ low in conjunction with a new address. To initiate the synchronous read again, a new address and $\overline{\text{AVD}}$ pulse is needed after the host has completed status reads or the device has completed the program or erase operation.

9.1.2.1. Continuous Linear Burst Read

(1) K8S1015ET(B)(Z)C : 66/83Mhz with the Sync MRS option (Extended Configuration Register)

(2) K8S1115ET(B)(Z)C : 108/133Mhz with the Sync MRS option (Extended Configuration Register)

The synchronous (burst) mode will automatically start on the rising edge of the $\overline{\text{CLK}}$ input while $\overline{\text{AVD}}$ is held low after Extended Mode Register Setting to $A13=0$, $A12=1$. If several $\overline{\text{CLK}}$ s exist in $\overline{\text{AVD}}$ low, the last rising edge is valid $\overline{\text{CLK}}$.

(3) K8S1215ET(B)(Z)C : 66/83Mhz with no option

(4) K8S1315ET(B)(Z)C : 108/133Mhz with no option

The synchronous (burst) mode will automatically start on the rising edge of the $\overline{\text{CLK}}$ input while $\overline{\text{AVD}}$ is held low. If several $\overline{\text{CLK}}$ s exist in $\overline{\text{AVD}}$ low, the last rising edge is valid $\overline{\text{CLK}}$.

The initial word is output t_{IAA} after the rising edge of the last $\overline{\text{CLK}}$ cycle. Subsequent words are output t_{BA} after the rising edge of each successive clock cycle, which automatically increments the internal address counter. Note that the device has internal address boundary that occurs every 16 words. When the device is crossing the first word boundary, additional clock cycles are needed before data appears for the next address. The number of additional clock cycle can vary from zero to thirteen cycles, and the exact number of additional clock cycle depends on not only the starting address of burst read but also programmable wait state setting. The RDY output indicates this condition to the system by pulsing low. The device will continue to output sequential burst data, wrapping around to address 000000h after it reaches the highest addressable memory location until the system asserts $\overline{\text{CE}}$ high or $\overline{\text{RESET}}$ low or $\overline{\text{AVD}}$ low in conjunction with a new address. (See Table 7.) The reset command does not terminate the burst read operation. When it accesses the bank is programming or erasing, continuous burst read mode will output status data. And status data will be sustained until the system asserts $\overline{\text{CE}}$ high or $\overline{\text{RESET}}$ low or $\overline{\text{AVD}}$ low in conjunction with a new address. **Note that at least 10ns is needed to start next burst read operation from terminating previous burst read operation in the case of asserting $\overline{\text{CE}}$ high.**

8-, 16-Word Linear Burst Read

As well as the Continuous Linear Burst Mode, there are two(8 & 16 word) linear wrap mode, in which a fixed number of words are read from consecutive addresses. In these modes, the addresses for burst read are determined by the group within which the starting address falls. The groups are sized according to the number of words read in a single burst sequence for a given mode.(See Table. 9)

[Table 9] Burst Address Groups (Wrap mode only)

Burst Mode	Group Size	Group Address Ranges
8 word	8 words	0-7h, 8-Fh, 10-17h,
16 word	16 words	0-Fh, 10-1Fh, 20-2Fh,

As an example: In wrap mode case, if the starting address in the 8-word mode is 2h, the address range to be read would be 0-7h, and the wrap burst sequence would be 2-3-4-5-6-7-0-1h. The burst sequence begins with the starting address written to the device, but wraps back to the first address in the selected group. In a similar manner, 16-word wrap mode begins its burst sequence on the starting address written to the device, and then wrap back to the first address in the selected address group.

9.2 Programmable Wait State

The programmable wait state feature indicates to the device the number of additional clock cycles that must elapse after \overline{AVD} is driven from low to high for burst read mode. Upon power up, the number of total initial access cycles defaults to fourteen.

9.3 Handshaking

The handshaking feature allows the host system to simply monitor the RDY signal from the device to determine when the initial word of burst data is ready to be read. To set the number of initial cycle for optimal burst mode, the host should use the programmable wait state configuration.(See "Set Burst Mode Configuration Register" for details.) The rising edge of RDY after \overline{OE} goes low indicates the initial word of valid burst data. (RDY can be low active by Extended configuration register A11 setting : RDY low indicates data valid) Using the autoselect command sequence, the handshaking feature will be verified in the device.

9.4 Set Burst Mode Configuration Register

The device uses a configuration register to set the various burst parameters : the number of initial cycles for burst and burst read mode. The burst mode configuration register must be set before the device enters burst mode. The burst mode configuration register is loaded with a three-cycle command sequences. On the third cycle, the data should be C0h, address bits A10-A0 should be 101_0101_0101b, and address bits A21-A11 set the code to be latched. The device returns to default setting after power up or hardware reset.

9.4.1. Programmable Wait State Configuration

This feature informs the device the number of clock cycles that must elapse after \overline{AVD} is driven from low to high before data will be available. This value is determined by the input frequency of the device. Address bits A14-A11 determine the setting. (See Configuration Register table 10.) The Programmable wait state setting instructs the device to set a particular number of clock cycles for the initial access in burst mode. Note that hardware reset will revert the wait state to the default setting, that is 14 initial cycles.

9.4.2. Burst Read Mode Setting

The device supports three different burst read modes : continuous linear mode, 8 and 16 word linear burst modes with wrap.

9.4.3. RDY Configuration

By default, the RDY pin will be high whenever there is valid data on the output. (RDY can be low active by Extended configuration register A11 setting : RDY low indicates data valid) The device can be set so that RDY goes active one data cycle before active data. Address bit A18 determines this setting. The RDY pin behaves same way in word boundary crossing case.

[Table 10] Burst Mode Configuration Register Table

Address Bit	Function	Settings (Binary)
A21	Output Driver Control	000 = setting 0
A20		001 = setting 1
A19		010 = setting 2 (Reserve)
		011 = setting 3 (Reserve)
A18	RDY Active	100 = setting 4 (default)
		101 = setting 5 (Reserve)
		110 = setting 6 (Reserve)
		111 = setting 7
A17	Burst Read Mode	0 = RDY active with data (default)
A16		1 = RDY active one clock cycle before data
A15		000 = Continuous (default)
		001 = 8-word linear with wrap
A14	Programmable Wait State	010 = 16-word linear with wrap
		011 ~ 111 = Reserve
A13	Programmable Wait State	0000 = Data is valid on the 4th active CLK edge after \overline{AVD} transition to VIH
A12		0001 = Data is valid on the 5th active CLK edge after \overline{AVD} transition to VIH (40Mhz*)
A11		0010 = Data is valid on the 6th active CLK edge after \overline{AVD} transition to VIH (50/54Mhz*)
		0011 = Data is valid on the 7th active CLK edge after \overline{AVD} transition to VIH (60/66Mhz*)
		0100 = Data is valid on the 8th active CLK edge after \overline{AVD} transition to VIH (70Mhz*)
		0101 = Data is valid on the 9th active CLK edge after \overline{AVD} transition to VIH (80/83Mhz*)
		0110 = Data is valid on the 10th active CLK edge after \overline{AVD} transition to VIH (90/100Mhz*)
		0111 = Data is valid on the 11th active CLK edge after \overline{AVD} transition to VIH (108/110Mhz*)
		1000 = Data is valid on the 12th active CLK edge after \overline{AVD} transition to VIH (120Mhz*)
		1001 = Data is valid on the 13th active CLK edge after \overline{AVD} transition to VIH (133Mhz*,default)
		1010 = Data is valid on the 14th active CLK edge after \overline{AVD} transition to VIH
1011 = Data is valid on the 15th active CLK edge after \overline{AVD} transition to VIH		
1100 ~ 1111 = Reserve		

NOTE :

Initial wait state should be set according to it's clock frequency. Table 10 recommend the program wait state for each clock frequencies.
Not 100% tested

[Table 11] Extended Configuration Register Table

Address Bit	Function	Settings (Binary)
A13	Read Mode	00 = Asynchronous Read Mode (default)
A12		01 = Synchronous Burst Read Mode
A11		10 ~ 11 = Reserve
	RDY Polarity	0 = RDY signal is active high (default)
		1 = RDY signal is active low

NOTE :

Default mode is asynchronous read mode. (A13=0, A12=0) In this mode device is still in asynchronous read even if it is in CLK rising while \overline{AVD} low condition.
To use synchronous read mode, user should set Extended Configuration Register (A13=0, A12=1). In this mode both of asynchronous and synchronous read mode is available.
The synchronous (burst) mode should be started on the last rising edge of the CLK input while \overline{AVD} is held low after Extended Mode Register Setting to A13=0, A12=1.

[Table 12] Burst Address Sequences

	Start Addr.	Burst Address Sequence		
		Continuous Burst	8-word Burst	16-word Burst
Wrap	0	0-1-2-3-4-5-6...	0-1-2-3-4-5-6-7	0-1-2-3 ... -D-E-F
	1	1-2-3-4-5-6-7...	1-2-3-4-5-6-7-0	1-2-3-4 ... -E-F-0
	2	2-3-4-5-6-7-8...	2-3-4-5-6-7-0-1	2-3-4-5 ... -F-0-1
	⋮	⋮	⋮	⋮

9.5 Output Driver Setting

The device supports four kinds of output driver setting for matching the system characteristics. The users can tune the output driver impedance of the data and RDY outputs by address bits A21-A19. (See Configuration Register Table) Table 13 shows which output driver would be tuned and the strength according to A21-A19. Upon power-up or reset, the register will revert to the default setting.

[Table 13] Output Driver setting Table

Address Bits	Value	Function
A21-A19	000	Driver Multiplier : 1/3
	001	Driver Multiplier : 1/2
	010	Reserve
	011	Reserve
	100	Driver Multiplier : 1 (default)
	101	Reserve
	110	Reserve
	111	Driver Multiplier : 1.5

9.6 Autoselect Mode

By writing the autoselect command sequences to the system, the device enters the autoselect mode. This mode can be read only by asynchronous read mode. The system can then read autoselect codes from the internal register (which is separate from the memory array). Standard asynchronous read cycle timings apply in this mode. The device offers the Autoselect mode to identify manufacturer and device type by reading a binary code. In addition, this mode allows the host system to verify the block protection or unprotection. Table 14 shows the address and data requirements. The autoselect command sequence may be written to an address within a bank that is in the read mode, erase-suspend-read mode or program-suspend-read mode. The autoselect command may not be written while the device is actively programming or erasing in the device. The autoselect command sequence is initiated by first writing two unlock cycles. This is followed by a third write cycle that contains the address and the autoselect command. Note that the block address is needed for the verification of block protection. The system may read at any address within the same bank any number of times without initiating another autoselect command sequence. And the burst read should be prohibited during Autoselect Mode. To terminate the autoselect operation, write Reset command(F0H) into the command register.

[Table 14] Autoselect Mode Description

Description	Address	Read Data
Manufacturer ID	(DA) + 00H	ECH
Device ID	(DA) + 01H	Top boot(3010H), Bottom boot(3011H), Uniform block(3012H)
Block Protection/Unprotection	(BA) + 02H	01H (protected), 00H (unprotected)
Handshaking	(DA) + 03H	0H : handshaking, 1H : non-handshaking

9.7 Standby Mode

When the \overline{CE} inputs is held at $V_{CC} \pm 0.2V$, and the system is not reading or writing, the device enters Stand-by mode to minimize the power consumption. In this mode, the device outputs are placed in the high impedance state, independent of the \overline{OE} input. When the device is in either of these standby modes, the device requires standard access time (t_{CE}) for read access before it is ready to read data. If the device is deselected during erasure or programming, the device draws active current until the operation is completed. I_{CC5} in the DC Characteristics table represents the standby current specification.

9.8 Automatic Sleep Mode

The device features Automatic Sleep Mode to minimize the device power consumption during both asynchronous and burst mode. When addresses remain stable for $t_{AA}+60ns$, the device automatically enables this mode. The Automatic sleep mode is depends on the \overline{CE} , \overline{WE} and \overline{OE} signal, so \overline{CE} , \overline{WE} and \overline{OE} signals are held at any state. In a sleep mode, output data is latched and always available to the system. When \overline{OE} is active, the device provides new data without wait time. Automatic sleep mode current is equal to standby mode current.

9.9 Output Disable Mode

When the \overline{OE} input is at V_{IH} , output from the device is disabled. The outputs are placed in the high impedance state.

9.10 Block Protection & Unprotection

To protect the block from accidental writes, the block protection/unprotection command sequence is used. On power up, all blocks in the device are protected. To unprotect a block, the system must write the block protection/unprotection command sequence. The first two cycles are written: addresses are don't care and data is 60h. Using the third cycle, the block address (ABP) and command (60h) is written, while specifying with addresses A6, A1 and A0 whether that block should be protected (A6 = V_{IL}, A1 = V_{IH}, A0 = V_{IL}) or unprotected (A6 = V_{IH}, A1 = V_{IH}, A0 = V_{IL}). After the third cycle, the system can continue to protect or unprotect additional cycles, or exit the sequence by writing F0h (reset command).

The device offers three types of data protection at the block level:

- The block protection/unprotection command sequence disables or re-enables both program and erase operations in any block.
- When \overline{WP} is at V_{IL}, the two outermost blocks are protected.(Boot block part : K8S(10/11/12/13)15ET(B)C)
- When \overline{WP} is at V_{IL}, the last one block (BA511) is protected.(Uniform block part :K8S(10/11/12/13)15EZC)
- When V_{PP} is at V_{IL}, all blocks are protected.

Note that user never float the V_{pp} and \overline{WP} , that is, V_{pp} is always connected with V_{IH}, V_{IL} or V_{DD} and \overline{WP} is V_{IH} or V_{IL}.

9.11 Hardware Reset

The device features a hardware method of resetting the device by the \overline{RESET} input. When the \overline{RESET} pin is held low (V_{IL}) for at least a period of t_{RP}, the device immediately terminates any operation in progress, tristates all outputs, and ignores all read/write commands for the duration of the \overline{RESET} pulse. The device also resets the internal state machine to asynchronous read mode. To ensure data integrity, the interrupted operation should be reinitiated once the device is ready to accept another command sequence. The \overline{RESET} pin may be tied to the system reset pin. If a system reset occurs during the Internal Program or Erase Routine, the device will be automatically reset to the asynchronous read mode; this will enable the systems microprocessor to read the boot-up firmware from the Flash memory. If \overline{RESET} is asserted during a program or erase operation, the device requires a time of t_{READY} (during Internal Routines) before the device is ready to read data again. If \overline{RESET} is asserted when a program or erase operation is not executing, the reset operation is completed within a time of t_{READY} (not during Internal Routines). t_{RH} is needed to read data after \overline{RESET} returns to V_{IH}. Refer to the AC Characteristics tables for \overline{RESET} parameters and to Figure 12 for the timing diagram. When \overline{RESET} is at logic high, the device is in standard operation.

9.12 Software Reset

The reset command provides that the bank is reseted to read mode, erase-suspend-read mode or program-suspend-read mode. The addresses are in Don't Care state. The reset command may be written between the sequence cycles in an erase command sequence before erasing begins, or in an program command sequence before programming begins. If the device begins erasure or programming, the reset command is ignored until the operation is completed. If the program command sequence is written to a bank that is in the Erase Suspend mode, writing the reset command returns that bank to the erase-suspend-read mode. The reset command valid between the sequence cycles in an autoselect command sequence. In an autoselect mode, the reset command must be written to return to the read mode. If a bank entered the autoselect mode while in the Erase Suspend mode, writing the reset command returns that bank to the erase-suspend-read mode. Also, if a bank entered the autoselect mode while in the Program Suspend mode, writing the reset command returns that bank to the program-suspend-read mode. If DQ5 goes high during a program or erase operation, writing the reset command returns the banks to the read mode. (or erase-suspend-read mode if the bank was in Erase Suspend)

9.13 Program

The K8S(10/11/12/13)15E can be programmed in units of a word. Programming is writing 0's into the memory array by executing the Internal Program Routine. In order to perform the Internal Program Routine, a four-cycle command sequence is necessary. The first two cycles are unlock cycles. The third cycle is assigned for the program setup command. In the last cycle, the address of the memory location and the data to be programmed at that location are written. The device automatically generates adequate program pulses and verifies the programmed cell margin by the Internal Program Routine. During the execution of the Routine, the system is not required to provide further controls or timings. During the Internal Program Routine, commands written to the device will be ignored.

9.14 Accelerated Program

The device provides accelerated program operations through the V_{pp} input. Using this mode, faster manufacturing throughput at the factory is possible. When V_{DD} is asserted on the V_{pp} input, the device automatically enters the Unlock Bypass mode, temporarily unprotects any protected blocks, and uses the higher voltage on the input to reduce the time required for program operations. In accelerated program mode, the system would use a two-cycle program command sequence for only a word program. By removing V_{DD} returns the device to normal operation mode.

Note that Read While Accelerated Program (Erase) and Program suspend (Erase suspend) mode are not guaranteed.

- Program/Eraser cycling must be limited below 100cycles for optimum performance.
- Ambient temperature requirements : T_A = 30°C±10°C

9.15 Write Buffer Programming

Write Buffer Programming allows the system write to a maximum of 512-word in one programming operation. This results in faster effective programming time than the standard programming algorithms. The Write Buffer Programming command sequence is initiated by first writing two unlock cycles. This is followed by a third write cycle containing the Write Buffer Load command written at the block address in which programming will occur. The fourth cycle writes the block address and the number of word locations, minus one, to be programmed. For example, if the system will program 19 unique address locations, then 12h should be written to the device. This tells the device how many write buffer addresses will be loaded with data. The number of locations to program cannot exceed the size of the write buffer or the operation will abort. The fifth cycle writes the first address location and data to be programmed. **The write-buffer-page is selected by address bits A24(max.) ~ A9 entered at fifth cycle. All subsequent address/ data pairs must fall within the selected write-buffer-page, so that all subsequent addresses must have the same address bit A24(max.) ~ A9 as those entered at fifth cycle. Write buffer locations may be loaded in any order.**

Once the specified number of write buffer locations have been loaded, the system must then write the "Program Buffer to Flash" command at the block address. Any other command address/data combination aborts the Write Buffer Programming operation. The device then begins programming. Data polling should be used while monitoring the last address location loaded into the write buffer. DQ7, DQ6, DQ5, and DQ1 should be monitored to determine the device status during Write Buffer Programming. The write-buffer programming operation can be suspended using the standard program suspend/resume commands. Upon successful completion of the Write Buffer Programming operation, the device is ready to execute the next command.

Note also that an address location cannot be loaded more than once into the write-buffer-page.

The Write Buffer Programming Sequence can be aborted in the following ways:

- Loading a value that is greater than the buffer size(512-word) during then number of word locations to Program step.
(In case, WC > 1FFh @Table 8)
- The number of Program address/data pairs entered is different to the number of word locations initially defined with WC (@Table 8)
- Writing a Program address to have a different write-buffer-page with selected write-buffer-page
(Address bits A24(max) ~ A9 are different)
- Writing non-exact "Program Buffer to Flash" command

The abort condition is indicated by DQ1 = 1, DQ7 = $\overline{\text{DATA}}$ (for the last address location loaded), DQ6 = toggle, and DQ5=0. A "Write-to-Buffer-Abort Reset" command sequence must be written to reset the device for the next operation. Note that the third cycle of Write-to-Buffer-Abort Reset command sequence is required when using Write-Buffer-Programming features in Unlock Bypass mode.

And from the third cycle to the last cycle of Write to Buffer command is also required when using Write-Buffer-Programming features in Unlock Bypass mode. A bit cannot be programmed from "0" back to a "1." Attempting to do so may cause the DQ7 and DQ6 status bits to indicate the operation was successful. However, a succeeding read will show that the data is still "0." Only erase operations can convert a "0" to a "1."

9.16 Accelerated Write Buffer Programming

The device provides accelerated Write Buffer Program operations through the Vpp input. Using this mode, faster manufacturing throughput at the factory is possible. When Vid is asserted on the Vpp input, the device temporarily unprotects any protected blocks, and uses the higher voltage on the input to reduce the time required for program operations. In accelerated Write Buffer Program mode, the system must enter "Write to Buffer" and "Program Buffer to Flash" command sequence to be same as them of normal Write Buffer Programming. Note that the third cycle of "Write to Buffer Abort Reset" command sequence is required in an accelerated mode.

Note that Read While Accelerated Write Buffer Program and Program suspend mode are not guaranteed.

- Program/Erase cycling must be limited below 100cycles for optimum performance.
- Ambient temperature requirements : T_A = 30°C±10°C

9.17 Chip Erase

To erase a chip is to write 1's into the entire memory array by executing the Internal Erase Routine. The Chip Erase requires six bus cycles to write the command sequence. The erase set-up command is written after first two "unlock" cycles. Then, there are two more write cycles prior to writing the chip erase command. The Internal Erase Routine automatically pre-programs and verifies the entire memory for an all zero data pattern prior to erasing. The automatic erase begins on the rising edge of the last WE pulse in the command sequence and terminates when DQ7 is "1". After that the device returns to the read mode.

9.18 Block Erase

To erase a block is to write 1's into the desired memory block by executing the Internal Erase Routine. The Block Erase requires six bus cycles to write the command sequence shown in Table 8. After the first two "unlock" cycles, the erase setup command (80H) is written at the third cycle. Then there are two more "unlock" cycles followed by the Block Erase command. The Internal Erase Routine automatically pre-programs and verifies the entire memory prior to erasing it. The block address is latched on the rising edge of \overline{AVD} , while the Block Erase command is latched on the rising edge of \overline{WE} . Multiple blocks can be erased sequentially by writing the sixth bus-cycle. Upon completion of the last cycle for the Block Erase, additional block address and the Block Erase command (30H) can be written to perform the Multi-Block Erase. For the Multi-Block Erase, only sixth cycle (block address and 30H) is needed. (Similarly, only second cycle is needed in unlock bypass block erase.) An 50us (typical) "time window" is required between the Block Erase command writes. The Block Erase command must be written within the 50us "time window", otherwise the Block Erase command will be ignored. The 50us "time window" is reset when the falling edge of the \overline{WE} occurs within the 50us of "time window" to latch the Block Erase command. During the 50us of "time window", any command other than the Block Erase or the Erase Suspend command written to the device will reset the device to read mode. After the 50us of "time window", the Block Erase command will initiate the Internal Erase Routine to erase the selected blocks. Any Block Erase address and command following the exceeded "time window" may or may not be accepted. No other commands will be recognized except the Erase Suspend command during Block Erase operation.

The device provides accelerated erase operations through the Vpp input. When VID is asserted on the Vpp input, the device automatically enters the Unlock Bypass mode, temporarily unprotects any protected blocks, and uses the higher voltage on the input to reduce the time required for erase. By removing VID returns the device to normal operation mode.

9.19 Blank check

The Blank Check operation is used one block at a time to check whether a block is completely erased or not. It is not available during Program Suspend or Erase Suspend. For using Blank Check, first issue the command which has 4-cycle and check the status. The Bank addressed in Blank Check Command is automatically changed to Status check mode, until Reset command (XXXH / F0H) is issued.

During a blank check operation, DQ status flags indicates a busy status (DQ6, DQ2 = toggle / DQ5=0). Upon completion, the DQ status flags indicates that Blank check operation is passed (DQ6 = toggle, DQ5=1 and DQ1=1). That means the block is completely erased.

In Blank check operation failure case, the DQ status flags indicates DQ6 = toggle, DQ5=1 and DQ1=0. The block is not completely erased.

No other commands will be recognized except status read operation during Blank Check operation. Blank Check cannot be suspended. After the completion of the Blank Check operation, any valid command can be issued after Reset command (XXXH / F0H).

NOTE that, unexpected power off or hardware reset during internal write routine may make blank check operation unavailable. And Blank check cannot be used in OTP block area.

9.20 Unlock Bypass

The K8S(10/11/12/13)15E provides the unlock bypass mode to save its operation time. This mode is possible for program, block erase, chip erase, write to buffer and write to buffer abort reset operation. There are two methods to enter the unlock bypass mode. The mode is invoked by the unlock bypass command sequence or the assertion of VID on VPP pin. Unlike the standard program/erase command sequence that contains four bus cycles, the unlock bypass program/erase command sequence comprises only two bus cycles. The unlock bypass mode is engaged by issuing the unlock bypass command sequence which is comprised of three bus cycles. Writing first two unlock cycles is followed by a third cycle containing the unlock bypass command (20H). Once the device is in the unlock bypass mode, the unlock bypass program/erase command sequence is necessary. The unlock bypass program command sequence is comprised of only two bus cycles; writing the unlock bypass program command (A0H) is followed by the program address and data. This command sequence is the only valid one for programming the device in the unlock bypass mode. Also, The unlock bypass erase command sequence is comprised of two bus cycles; writing the unlock bypass block erase command(80H-30H) or writing the unlock bypass chip erase command(80H-10H). This command sequences are the only valid ones for erasing the device in the unlock bypass mode. The unlock bypass reset command sequence is the only valid command sequence to exit the unlock bypass mode. The unlock bypass reset command sequence consists of two bus cycles. The first cycle must contain the data (90H). The second cycle contains only the data (00H). Then, the device returns to the read mode.

To enter the unlock bypass mode in hardware level, the VID also can be used. By assertion VID on the VPP pin, the device enters the unlock bypass mode.

Also, the all blocks are temporarily unprotected when the device using the VID for unlock bypass mode. To exit the unlock bypass mode, just remove the asserted VID from the VPP pin. (Note that user never float the Vpp, that is, Vpp is always connected with VIH, VIL or VID.).

9.21 Erase Suspend / Resume

The Erase Suspend command interrupts the Block Erase to read or program data in a block that is not being erased. Also, it is possible to protect or unprotect of the block that is not being erased in erase suspend mode. The Erase Suspend command is only valid during the Block Erase operation including the time window of 50us. The Erase Suspend command is not valid while the Chip Erase or the Internal Program Routine sequence is running. When the Erase Suspend command is written during a Block Erase operation, the device requires a maximum of 30us(recovery time) to suspend the erase operation. Therefore system must wait for 30us(recovery time) to read the data from the bank which include the block being erased. Otherwise, system can read the data immediately from a bank which don't include the block being erased without recovery time (max. 30us) after Erase Suspend command. And, after the maximum 30us recovery time, the device is available for programming data in a block that is not being erased. But, when the Erase Suspend command is written during the block erase time window (50us), the device terminates the block erase time window and suspends the erase operation in about 2us. The system may also write the autoselect command sequence when the device is in the Erase Suspend mode. When the Erase Resume command is executed, the Block Erase operation will resume. When the Erase Suspend or Erase Resume command is executed, the addresses are in the bank address which is operating in Erase Suspend or Erase Resume. **While erase can be suspended and resumed multiple times, a minimum 30us is required from resume to the next suspend.**

9.22 Program Suspend / Resume

The device provides the Program Suspend/Resume mode. This mode is used to enable Data Read by suspending the Program operation. The device accepts a Program Suspend command in Program mode (including Program operations performed during Erase Suspend) but other commands are ignored. After input of the Program Suspend command, 10us is needed to enter the Program Suspend Read mode. Therefore system must wait for 10us(recovery time) to read the data from the bank which include the block being programmed. Otherwise, system can read the data immediately from a bank which don't include block being programmed without recovery time(max.10us) after Program Suspend command. Like an Erase Suspend mode, the device can be returned to Program mode by using a Program Resume command. **While program can be suspended and resumed multiple times, a minimum 30us is required from resume to the next suspend.**

In the program suspend mode, protect/unprotect command is prohibited.

9.23 Read While Write Operation

The device is capable of reading data from one bank while writing in the other banks. This is so called the Read While Write operation. An erase operation may also be suspended to read from or program to another location within the same bank (except the block being erased). The Read While Write operation is prohibited during the chip erase operation. Figure 19 shows how read and write cycles may be initiated for simultaneous operation with zero latency. Refer to the DC Characteristics table for read-while-write current specifications.

9.24 OTP Block Region

The OTP Block feature provides a 512-word Flash memory region that enables permanent part identification through an Electronic Serial Number (ESN). The OTP Block is customer lockable and shipped with itself unlocked, allowing customers to utilize the that block in any manner they choose. The customer-lockable OTP Block has the Protection Verify Bit (DQ0) set to a "0" for Unlocked state or a "1" for Locked state.

The system accesses the OTP Block through a command sequence (see "Enter OTP Block / Exit OTP Block Command sequence" at Table 8). After the system has written the "Enter OTP Block" Command sequence, it may read the OTP Block by using the addresses (1FFFE00h~1FFFFFFh : Top Boot block device/Uniform block device, 0000000h~00001FFh : Bottom Boot block device) normally and may check the Protection Verify Bit (DQ0) by using the "Autoselect Block Protection Verify" Command sequence with OTP Block address. This mode of operation continues until the system issues the "Exit OTP Block" Command sequence, a hardware reset or until power is removed from the device. On power-up, or following a hardware reset, the device reverts to sending commands to main blocks. Note that the Accelerated function and unlock bypass modes are not available when the OTP Block is enabled.

Customer Lockable

In a Customer lockable device, The OTP Block is one-time programmable and can be locked only once. Note that the Accelerated programming and Unlock bypass functions are not available when programming the OTP Block. Locking operation to the OTP Block is started by writing the "Enter OTP Block" Command sequence, and then the "Block Protection" Command sequence (Table 8) with an OTP Block address. The Locking operation has to be above 100us. "Exit OTP Block" command sequence and Hardware reset makes locking operation finished and then exiting from OTP Block after 30us.

The OTP Block Lock operation must be used with caution since, once locked, there is no procedure available for unlocking and none of the bits in the OTP Block space can be modified in any way.

Suspend and resume operation are not supported during OTP protect, nor is OTP protect supported during any suspend operations. After entering OTP block, program/erase operation on main blocks is prohibited. Enter OTP block command is not allowed while other operation is executing.

9.25 Low V_{CC} Write Inhibit

To avoid initiation of a write cycle during V_{CC} power-up and power-down, a write cycle is locked out for V_{CC} less than V_{LKO}. If the V_{CC} < V_{LKO} (Lock-Out Voltage), the command register and all internal program/erase circuits are disabled. Under this condition the device will reset itself to the read mode. Subsequent writes will be ignored until the V_{CC} level is greater than V_{LKO}. It is the user's responsibility to ensure that the control pins are logically correct to prevent unintentional writes when V_{CC} is above V_{LKO}.

9.26 Write Pulse "Glitch" Protection

Noise pulses of less than 5ns (typical) on \overline{OE} , \overline{CE} , \overline{AVD} or \overline{WE} do not initiate a write cycle.

9.27 Logical Inhibit

Write cycles are inhibited by holding any one of $\overline{OE} = V_{IL}$, $\overline{CE} = V_{IH}$ or $\overline{WE} = V_{IH}$. To initiate a write cycle, \overline{CE} and \overline{WE} must be a logical zero while \overline{OE} is a logical one.

10.0 FLASH MEMORY STATUS FLAGS

The K8S(10/11/12/13)15E has means to indicate its status of operation in the bank where a program or erase operation is in processes. Address must include bank address being executed internal routine operation. The status is indicated by raising the device status flag via corresponding DQ pins. The status data can be read during burst read mode by using AVD signal with a bank address. That means status read is supported in synchronous mode. If status read is performed, the data provided in the burst read is identical to the data in the initial access. To initiate the synchronous read again, a new address and AVD pulse is needed after the host has completed status reads or the device has completed the program or erase operation. The corresponding DQ pins are DQ7, DQ6, DQ5, DQ3, DQ2 and DQ1.

[Table 15] Hardware Sequence Flags

Status		DQ7	DQ6	DQ5	DQ3	DQ2	DQ1	
In Progress	Programming	$\overline{DQ7}$	Toggle	0	0	1	0	
	Block Erase or Chip Erase or Blank check	0	Toggle	0	1	Toggle	0	
	Erase Suspend Read	Erase Suspended Block	1	1	0	0	Toggle ¹⁾	0
	Erase Suspend Read	Non-Erase Suspended Block	Data	Data	Data	Data	Data	Data
	Erase Suspend Program	Non-Erase Suspended Block	$\overline{DQ7}$	Toggle	0	0	1	0
	Program Suspend Read	Program Suspended Block	DQ7	1	0	0	Toggle ¹⁾	0
	Program Suspend Read	Non-program Suspended Block	Data	Data	Data	Data	Data	Data
Exceeded Time Limits	Programming	$\overline{DQ7}$	Toggle	1	0	No Toggle	0	
	Block Erase or Chip Erase or Blank check Fail	0	Toggle	1	1	(NOTE 2)	0	
	Blank check Pass	0	Toggle	1	1	(NOTE 2)	1	
	Erase Suspend Program	$\overline{DQ7}$	Toggle	1	0	No Toggle	0	
Write-to-Buffer ³⁾	BUSY state	$\overline{DQ7}$	Toggle	0	0	No Toggle	0	
	Exceeded Timing Limits	$\overline{DQ7}$	Toggle	1	0	No Toggle	0	
	ABORT State	$\overline{DQ7}$	Toggle	0	0	No Toggle	1	

NOTE :

- 1) DQ2 will toggle when the device performs successive read operations from the erase/program suspended block.
- 2) If DQ5 is High (exceeded timing limits), successive reads from a problem block will cause DQ2 to toggle.
- 3) Note that $\overline{DQ7}$ during Write-to-Buffer-Programming indicates the data-bar for DQ7 data for the last loaded write-buffer address location.

DQ7 : Data Polling

When an attempt to read the device is made while executing the Internal Program, the complement of the data is written to DQ7 as an indication of the Routine in progress. When the Routine is completed an attempt to access to the device will produce the true data written to DQ7. When a user attempts to read the block being erased or bank contains the block, DQ7 will be low. If the device is placed in the Erase/Program Suspend Mode, the status can be detected via the DQ7 pin. If the system tries to read an address which belongs to a block that is being erase suspended, DQ7 will be high. And, if the system tries to read an address which belongs to a block that is being program suspended, the output will be the true data of DQ7 itself. If a non-erase-suspended or non-program-suspended block address is read, the device will produce the true data to DQ7. If an attempt is made to program a protected block, DQ7 outputs complements the data for approximately 2us and the device then returns to the Read Mode without changing data in the block. If an attempt is made to erase a protected block, DQ7 outputs complement data in approximately 100us and the device then returns to the Read Mode without erasing the data in the block.

DQ6 : Toggle Bit

Toggle bit is another option to detect whether an Internal Routine is in progress or completed. Once the device is at a busy state, DQ6 will toggle. Toggling DQ6 will stop after the device completes its Internal Routine. If the device is in the Erase/Program Suspend Mode, an attempt to read an address that belongs to a block that is being erased or programmed will produce a high output of DQ6. If an address belongs to a block that is not being erased or programmed, toggling is halted and valid data is produced at DQ6. If an attempt is made to program a protected block, DQ6 toggles for approximately 2us and the device then returns to the Read Mode without changing the data in the block. If an attempt is made to erase a protected block, DQ6 toggles for approximately 100μs and the device then returns to the Read Mode without erasing the data in the block. #OE or #CE should be toggled in each toggle bit status read.

DQ5 : Exceed Timing Limits

If the Internal Program/Erase Routine extends beyond the timing limits, DQ5 will go High, indicating program/erase failure. Also the result of blank check can be checked by DQ5=1.

DQ3 : Block Erase Timer

The status of the multi-block erase operation can be detected via the DQ3 pin. DQ3 will go High if 50µs of the block erase time window expires. In this case, the Internal Erase Routine will initiate the erase operation. Therefore, the device will not accept further write commands until the erase operation is completed. DQ3 is Low if the block erase time window is not expired. Within the block erase time window, an additional block erase command (30H) can be accepted. To confirm that the block erase command has been accepted, the software may check the status of DQ3 following each block erase command.

DQ2 : Toggle Bit 2

The device generates a toggling pulse in DQ2 only if an Internal Erase Routine or an Erase/Program Suspend is in progress. When the device executes the Internal Erase Routine, DQ2 toggles if the bank including an erasing block is read. Although the Internal Erase Routine is in the Exceeded Time Limits, DQ2 toggles only if an erasing block in the Exceeded Time Limits is read. When the device is in the Erase/Program Suspend mode, DQ2 toggles only if an address in the erasing or programming block is read. If a non-erasing or non-programmed block address is read during the Erase/Program Suspend mode, then DQ2 will produce valid data. DQ2 will go High if the user tries to program a non-erase suspend block while the device is in the Erase Suspend mode. #OE or #CE should be toggled in each toggle bit status read.

DQ1 : Buffer Program Abort Indicator

DQ1 indicates whether a Write-to-Buffer operation was aborted. Under these conditions DQ1 produces a "1". The system must issue the Write-to-Buffer-Abort-Reset command sequence to return the device to reading array data. Also DQ1 will go High if the blank check is passed. DQ1 will go low in the blank check failure.

RDY: Ready

Normally the RDY signal is used to indicate if new burst data is available at the rising edge of the clock cycle or not. If RDY is low state, data is not valid at expected time, and if high state, data is valid. Note that, if \overline{CE} is low and \overline{OE} is high, the RDY is high state.

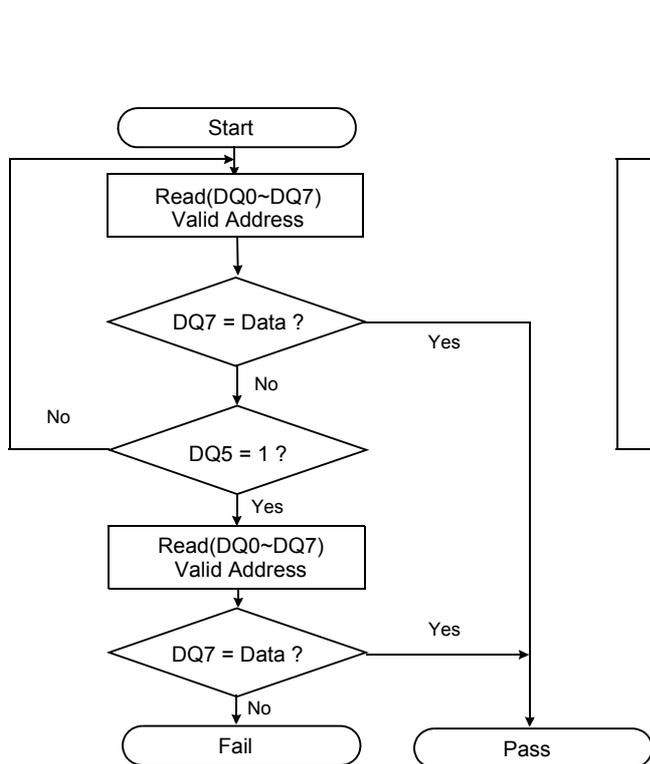

Figure 1. Data Polling Algorithms

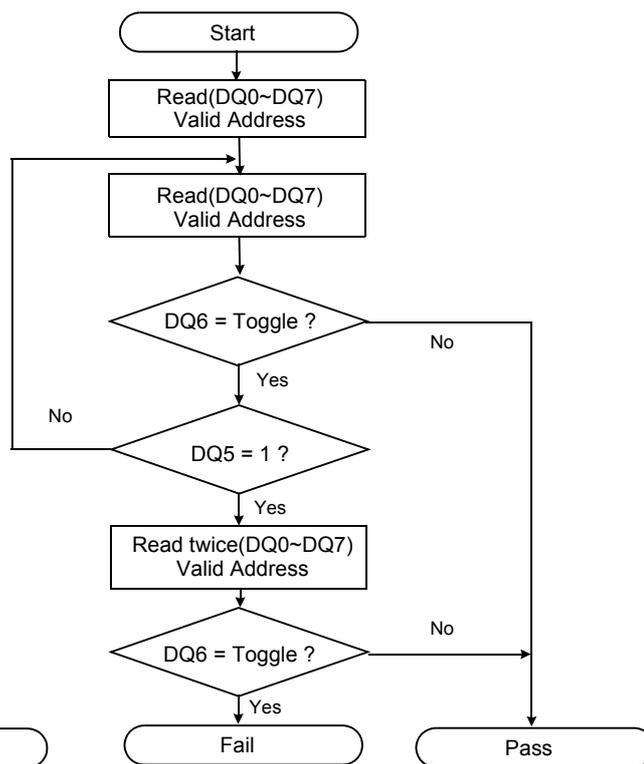

Figure 2. Toggle Bit Algorithms

11.0 Deep Power Down

In order to reduce the power consumption of the device, it shall a deep power down mode implemented on a separate pin. The deep power down mode is active when the deep power down signal is activated, high state. In deep power down the device shall turn off all circuitry in order to reach a power consumption of 2uA(typ). The device shall exit the deep power down mode within 75us after that the deep power down signal has been de-activated, set to low. In deep power down the state of the device chip select shall have no impact on the device power consumption. All programming capabilities of the device are inhibited.

At the power up, the device shall accept any order of activation of the reset and deep power down signal. The device shall respond within the specified time for the signal that was deactivated/activated latest. The deep power down mode is activated when DPD pin high state only. If DPD is asserted during a program or erase operation, the device requires a time of t_{DP} (During Internal Routines) before the device is ready to enter DPD mode.

Note that user never float the DPD that is, DPD is always connected with V_{IH} , V_{IL} .

Deep Power Down (DPD)

Parameter	Symbol	All Speed Options			Unit
		Min	Typ	Max	
DPD Pin High (NOT During Internal Routines) to DPD Mode*	t_{DP}	100	-	-	ns
DPD Pin High (During Internal Routines) to DPD Mode*	t_{DP}	20	-	-	μ s
DPD Low Time Before Read*	t_{wkup}	75	-	-	μ s

NOTE : Not 100% tested.

SWITCHING WAVEFORMS

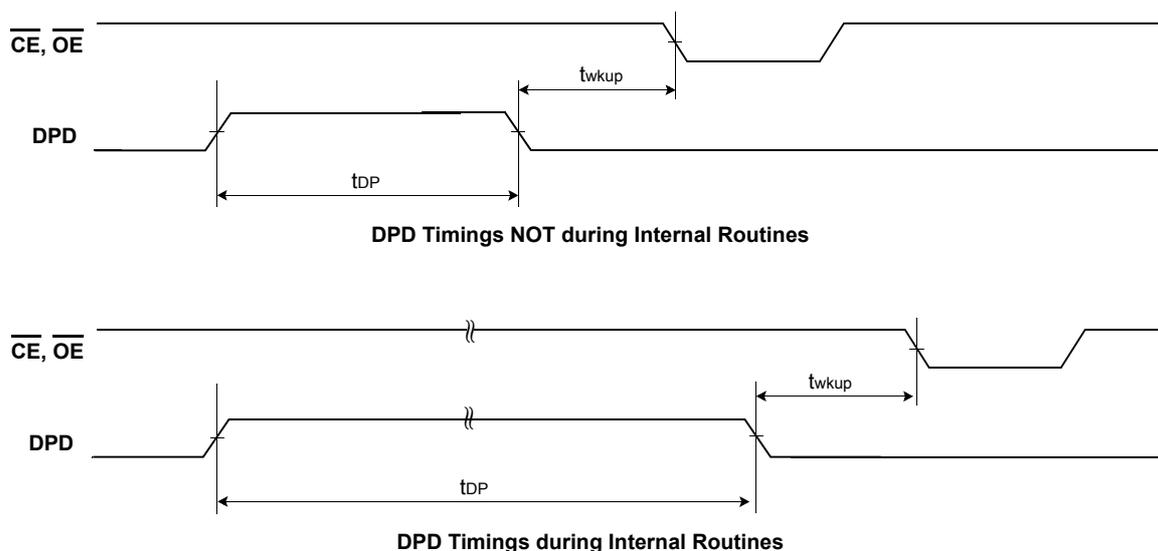

Figure 3. DPD Timings

12.0 Common Flash Memory Interface

Common Flash Memory Interface is contrived to increase the compatibility of host system software. It provides the specific information of the device, such as memory size and electrical features. Once this information has been obtained, the system software will know which command sets to use to enable flash writes, block erases, and control the flash component.

When the system writes the CFI command(98H) to address 55H, the device enters the CFI mode. And then if the system writes the address shown in Table 16, the system can read the CFI data. Query data are always presented on the lowest-order data outputs(DQ0-7) only. In word(x16) mode, the upper data outputs(DQ8-15) is 00h. To terminate this operation, the system must write the reset command.

[Table 16] Common Flash Memory Interface Code

Description	Addresses (Word Mode)	Data
Query Unique ASCII string "QRY"	10H 11H 12H	0051H 0052H 0059H
Primary OEM Command Set	13H 14H	0002H 0000H
Address for Primary Extended Table	15H 16H	0040H 0000H
Alternate OEM Command Set (00h = none exists)	17H 18H	0000H 0000H
Address for Alternate OEM Extended Table (00h = none exists)	19H 1AH	0000H 0000H
Vcc Min. (write/erase) D7-D4: volt, D3-D0: 100 millivolt	1BH	0017H
Vcc Max. (write/erase) D7-D4: volt, D3-D0: 100 millivolt	1CH	0019H
Vpp (Acceleration Program) Supply Minimum 00 = Not Supported, D7 - D4 : Volt, D3 - D0 : 100mV	1DH	0085H
Vpp (Acceleration Program) Supply Maximum 00 = Not Supported, D7 - D4 : Volt, D3 - D0 : 100mV	1EH	0095H
Typical timeout per single word write 2 ^N us	1FH	0007H
Typical timeout for Max buffer write 2 ^N us(00H = not supported)	20H	000AH
Typical timeout per individual block erase 2 ^N ms	21H	000AH
Typical timeout for full chip erase 2 ^N ms(00H = not supported)	22H	0013H
Max. timeout for word write 2 ^N times typical	23H	0003H
Max. timeout for buffer write 2 ^N times typical	24H	0003H
Max. timeout per individual block erase 2 ^N times typical	25H	0003H
Max. timeout for full chip erase 2 ^N times typical(00H = not supported)	26H	0003H
Device Size = 2 ^N byte	27H	001AH
Flash Device Interface description	28H 29H	0000H 0000H
Max. number of byte in multi-byte write = 2 ^N	2AH 2BH	000AH 0000H
Number of Erase Block Regions within device ¹⁾	2CH	0002H
Erase Block Region 1 Information (Boot block part : (K8S(10/11/12/13)ET(B)C)) Bits 0~15: y+1=block number Bits 16~31: block size= z x 256bytes	2DH 2EH 2FH 30H	0003H 0000H 0080H 0000H

Description	Addresses (Word Mode)	Data
Erase Block Region 1 Information (Uniform block part : (K8S(10/11/12/13)EZC)) Bits 0~15: y+1=block number Bits 16~31: block size= z x 256bytes	2DH 2EH 2FH 30H	00FFH 0001H 0000H 0002H
Erase Block Region 2 Information (Boot block part : (K8S(10/11/12/13)ET(B)C))	31H 32H 33H 34H	00FEH 0001H 0000H 0002H
Erase Block Region 2 Information (Uniform block part : (K8S(10/11/12/13)EZC))	31H 32H 33H 34H	0000H 0000H 0000H 0000H
Erase Block Region 3 Information	35H 36H 37H 38H	0000H 0000H 0000H 0000H
Erase Block Region 4 Information	39H 3AH 3BH 3CH	0000H 0000H 0000H 0000H
Query-unique ASCII string "PR!"	40H 41H 42H	0050H 0052H 0049H
Major version number, ASCII	43H	0031H
Minor version number, ASCII	44H	0031H
Address Sensitive Unlock(Bits 1-0) 0 = Required, 1= Not Required Silcon Revision Number(Bits 7-2)	45H	0000H
Erase Suspend 0 = Not Supported, 1 = To Read Only, 2 = To Read & Write	46H	0002H
Block Protect 00 = Not Supported, 01 = Supported	47H	0001H
Block Temporary Unprotect 00 = Not Supported, 01 = Supported	48H	0000H
Block Protect/Unprotect scheme 00 = Not Supported, 01 = Supported	49H	0001H
Simultaneous Operation 00 = Not Supported, 01 = Supported	4AH	0001H
Burst Mode Type 00 = Not Supported, 01 = Supported	4BH	0001H
Page Mode Type 00 = Not Supported, 01 = 4 Word Page, 02 = 8 Word Page, 03 = 16 Word Page	4CH	0000H
Top/Bottom Boot/Uniform Block Flag 02H = Bottom Boot Device, 03H = Top Boot Device, 04H = Uniform Device	4DH	0003H
Max. Operating Clock Frequency (MHz) ²⁾	4EH	0085H
RWW(Read While Write) Functionality Restriction (00H = non exists, 01H = exists)	4FH	0000H
Handshaking 00 = Not Supported at both mode, 01 = Supported at Sync. Mode 10 = Supported at Async. Mode, 11 = Supported at both Mode	50H	0001H

NOTE :

1) Uniform block part (K8S(10/11/12/13)EZC) : Data is 01H

Boot block part (K8S(10/11/12/13)ET(B)C) : Data is 02H

2) Max. Operating Clock Frequency : Data is 85H in 108/133Mhz part (K8S(11/13)15E(T/B/Z)C), Data is 53H in 66/83Mhz part (K8S(10/12)15E(T/B/Z)C)

13.0 ABSOLUTE MAXIMUM RATINGS

Parameter		Symbol	Rating	Unit
Voltage on any pin relative to V _{SS}	V _{CC}	V _{CC}	-0.5 to +2.5	V
	V _{PP}	V _{IN}	-0.5 to +9.5	
	All Other Pins		-0.5 to +2.5	
Storage Temperature		T _{stg}	-65 to +100	°C
Short Circuit Output Current		I _{OS}	5	mA
Operating Temperature		T _A (Commercial Temp.)	0 to +70	°C
		T _A (Extended Temp.)	-25 to +85	°C

NOTE :

- 1) Minimum DC voltage is -0.5V on Input/ Output pins. During transitions, this level may fall to -2.0V for periods <20ns.
Maximum DC voltage is V_{CC}+0.6V on input / output pins which, during transitions, may overshoot to V_{CC}+2.0V for periods <20ns.
- 2) Minimum DC input voltage is -0.5V on V_{PP}. During transitions, this level may fall to -2.0V for periods <20ns.
Maximum DC input voltage is +9.5V on V_{PP} which, during transitions, may overshoot to +12.0V for periods <20ns.
- 3) Permanent device damage may occur if ABSOLUTE MAXIMUM RATINGS are exceeded. Functional operation should be restricted to the conditions detailed in the operational sections of this data sheet. Exposure to absolute maximum rating conditions for extended periods may affect reliability.

14.0 RECOMMENDED OPERATING CONDITIONS

Parameter	Symbol	Min	Typ.	Max	Unit
Supply Voltage	V _{CC}	1.7	1.8	1.95	V
Supply Voltage	V _{SS}	0	0	0	V

NOTE : Voltage reference to GND

1) Data retention is not guaranteed on Operating condition Extended temperature(-25°C~85°C) over.

15.0 DC CHARACTERISTICS

Parameter	Symbol	Test Conditions	Min	Typ	Max	Unit
Input Leakage Current	I _{LI}	V _{IN} =V _{SS} to V _{CC} , V _{CC} =V _{CCmax}	- 1.0	-	+ 1.0	μA
VPP Leakage Current	I _{LIP}	V _{CC} =V _{CCmax} , V _{PP} =V _{CCmax}	- 1.0	-	+ 1.0	μA
		V _{CC} =V _{CCmax} , V _{PP} =9.5V	-	-	35	μA
Output Leakage Current	I _{LO}	V _{OUT} =V _{SS} to V _{CC} , V _{CC} =V _{CCmax} , \overline{OE} =V _{IH}	- 1.0	-	+ 1.0	μA
Active Burst Read Current	I _{CCB1}	\overline{CE} =V _{IL} , \overline{OE} =V _{IH} (@133MHz)	-	35	55	mA
Active Asynchronous Read Current	I _{CC1}	\overline{CE} =V _{IL} , \overline{OE} =V _{IH} 10MHz	-	35	55	mA
Active Write Current ²⁾	I _{CC2}	\overline{CE} =V _{IL} , \overline{OE} =V _{IH} , \overline{WE} =V _{IL} , V _{PP} =V _{IH}	-	25	40	mA
Read While Write Current	I _{CC3}	\overline{CE} =V _{IL} , \overline{OE} =V _{IH}	-	45	70	mA
Accelerated Program Current	I _{CC4}	\overline{CE} =V _{IL} , \overline{OE} =V _{IH} , V _{PP} =9.5V	-	20	30	mA
Standby Current	I _{CC5}	\overline{CE} = \overline{RESET} =V _{CC} ± 0.2V	-	30	120	μA
Standby Current During Reset	I _{CC6}	\overline{RESET} = V _{SS} ± 0.2V	-	30	120	μA
Automatic Sleep Mode ³⁾	I _{CC7}	\overline{CE} =V _{SS} ± 0.2V, Other Pins=V _{IL} or V _{IH} V _{IL} = V _{SS} ± 0.2V, V _{IH} = V _{CC} ± 0.2V	-	30	120	μA
Deep Power Down Mode	I _{CC8}		-	2	30	μA
Input Low Voltage	V _{IL}		-0.5	-	0.4	V
Input High Voltage	V _{IH}		V _{CC} -0.4	-	V _{CC} +0.4	V
Output Low Voltage	V _{OL}	I _{OL} = 100 μA, V _{CC} =V _{CCmin}	-	-	0.1	V
Output High Voltage	V _{OH}	I _{OH} = -100 μA, V _{CC} =V _{CCmin}	V _{CC} -0.1	-	-	V
Voltage for Accelerated Program	V _{ID}		8.5	9.0	9.5	V
Low VCC Lock-out Voltage	V _{LKO}		-	-	1.4	V
Vpp current in program/erase	I _{vpp}	V _{PP} = 9.5V	-	0.8	5	mA
		V _{PP} = 1.95V	-	-	50	μA

NOTE :

1) Maximum ICC specifications are tested with V_{CC} = V_{CCmax}.

2) I_{CC} active while Internal Erase or Internal Program is in progress.

3) Device enters automatic sleep mode when addresses are stable for t_{AA} + 60ns.

16.0 VCC POWER-UP

Parameter	Symbol	All Speed Options		Unit
		Min	Max	
Vcc Setup Time	t_{VCS}	200	-	μs
Time between \overline{RESET} (high) and \overline{CE} (low)	t_{RH}	200	-	ns

NOTE : Not 100% tested.

SWITCHING WAVEFORMS

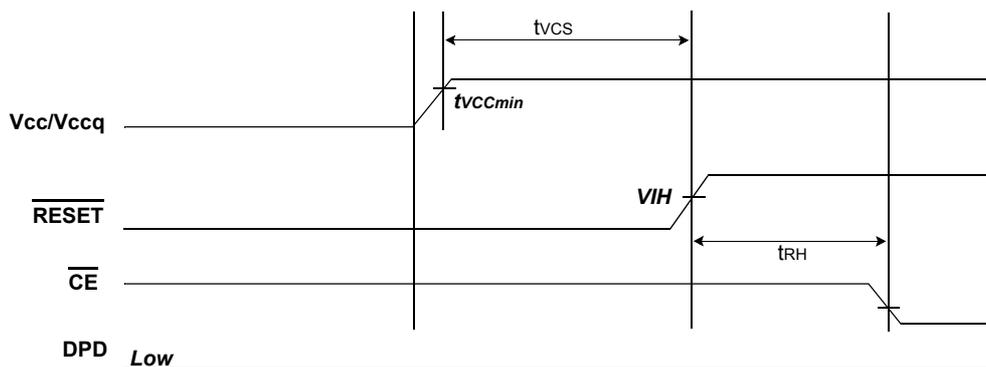

Figure 4. Vcc Power-up Diagram

NOTE : DPD should be low during power-up sequence.

17.0 CAPACITANCE (TA = 25 °C, VCC = 1.8V, f = 1.0MHz)

Item	Symbol	Test Condition	Min	Max	Unit
Input Capacitance	C_{IN}	$V_{IN}=0V$	-	10	pF
Output Capacitance	C_{OUT}	$V_{OUT}=0V$	-	10	pF
Control Pin Capacitance	C_{IN2}	$V_{IN}=0V$	-	10	pF

18.0 AC TEST CONDITION

Parameter	Value
Input Pulse Levels	0V to V _{CC}
Input Rise and Fall Times	3ns(max)@66Mhz, 2.5ns(max)@83Mhz, 1.5ns(max)@108Mhz, 1ns(max)@133Mhz
Input and Output Timing Levels	V _{CC} /2
Output Load	C _L = 30pF
Address to Address Skew	3ns(max)

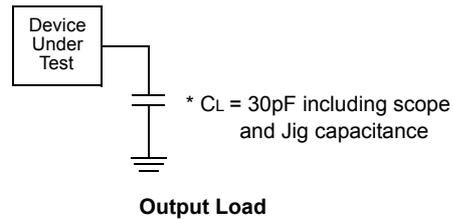
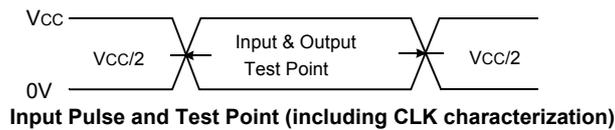

19.0 AC CHARACTERISTICS

19.1 Synchronous/Burst Read

Parameter	Symbol	1C (66 MHz)		1D (83 MHz)		1E (108 MHz)		1F (133 MHz)		Unit
		Min	Max	Min	Max	Min	Max	Min	Max	
Initial Access Time	t _{IAA}	-	95	-	95	-	95	-	95	ns
Burst Access Time Valid Clock to Output Delay	t _{BA}	-	11	-	9	-	7	-	6	ns
$\overline{\text{AVD}}$ Setup Time to CLK	t _{AVDS}	5	-	4	-	3.5	-	2.5	-	ns
$\overline{\text{AVD}}$ Hold Time from CLK	t _{AVDH}	2	-	2	-	2	-	2	-	ns
$\overline{\text{AVD}}$ High to $\overline{\text{OE}}$ Low	t _{AVDO}	0	-	0	-	0	-	0	-	ns
Address Setup Time to CLK	t _{ACS}	5	-	4	-	3.5	-	2.5	-	ns
Address Hold Time from CLK	t _{ACH}	6	-	5	-	2	-	2	-	ns
Data Hold Time from Next Clock Cycle	t _{BDH}	3	-	3	-	2	-	2	-	ns
Output Enable to RDY valid	t _{OER}	-	11	-	9	-	7	-	6	ns
$\overline{\text{CE}}$ Disable to High Z	t _{CEZ}	-	9	-	9	-	9	-	9	ns
$\overline{\text{OE}}$ Disable to High Z	t _{OEZ}	-	9	-	9	-	9	-	9	ns
$\overline{\text{CE}}$ Setup Time to CLK	t _{CES}	6	-	4.5	-	4	-	3.5	-	ns
$\overline{\text{CE}}$ Enable to RDY active	t _{RDY}	-	11	-	9	-	7	-	6	ns
CLK to RDY Setup Time	t _{RDYA}	-	11	-	9	-	7	-	6	ns
RDY Setup Time to CLK	t _{RDYS}	3	-	3	-	2	-	2	-	ns
CLK period	t _{CLK}	15.1	-	12.05	-	9.26	-	7.52	-	ns
CLK High or Low Time	t _{CLKH/L}	0.4x t _{CLK}	0.6x t _{CLK}	0.4x t _{CLK}	0.6x t _{CLK}	0.4x t _{CLK}	0.6x t _{CLK}	0.4x t _{CLK}	0.6x t _{CLK}	ns
CLK Fall or Rise Time	t _{CLKHCL}	-	3	-	2.5	-	1.5	-	1	ns

SWITCHING WAVEFORMS

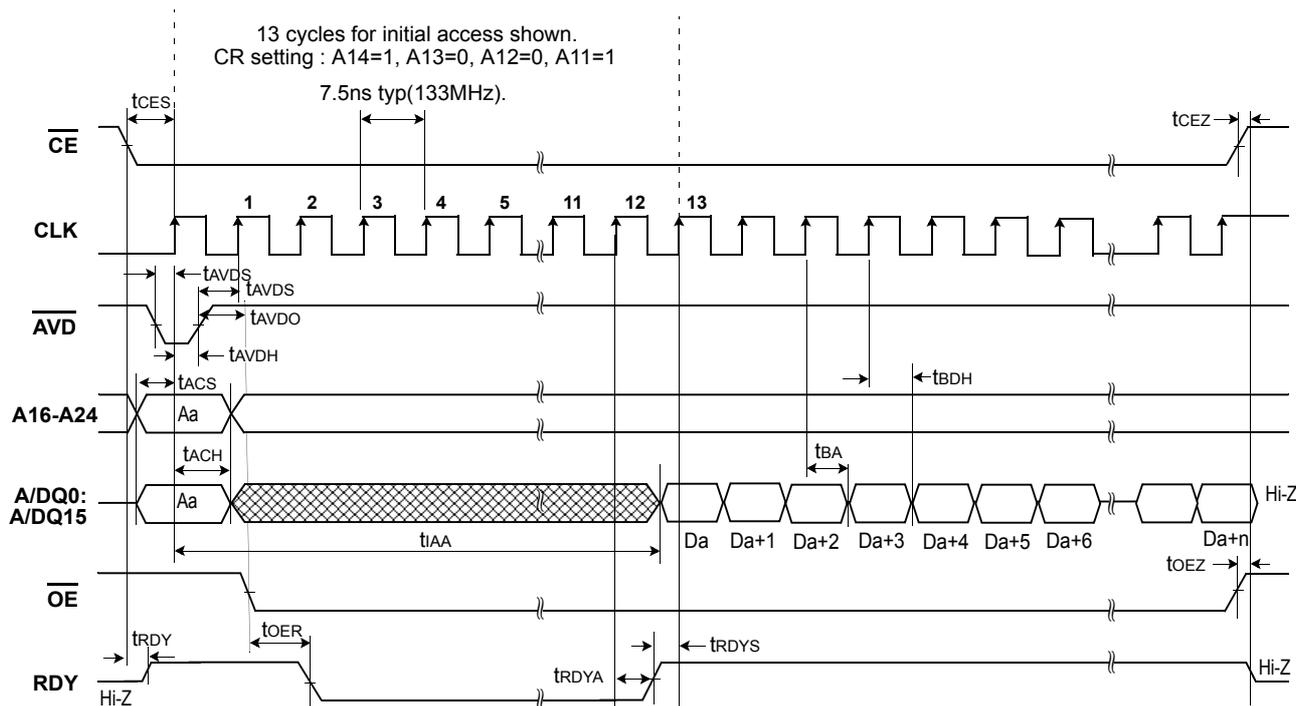

Figure 5. Continuous Burst Mode Read (133 MHz)

NOTE : In order to avoid a bus conflict the OE signal is enabled on the next rising edge after AVD is going high.

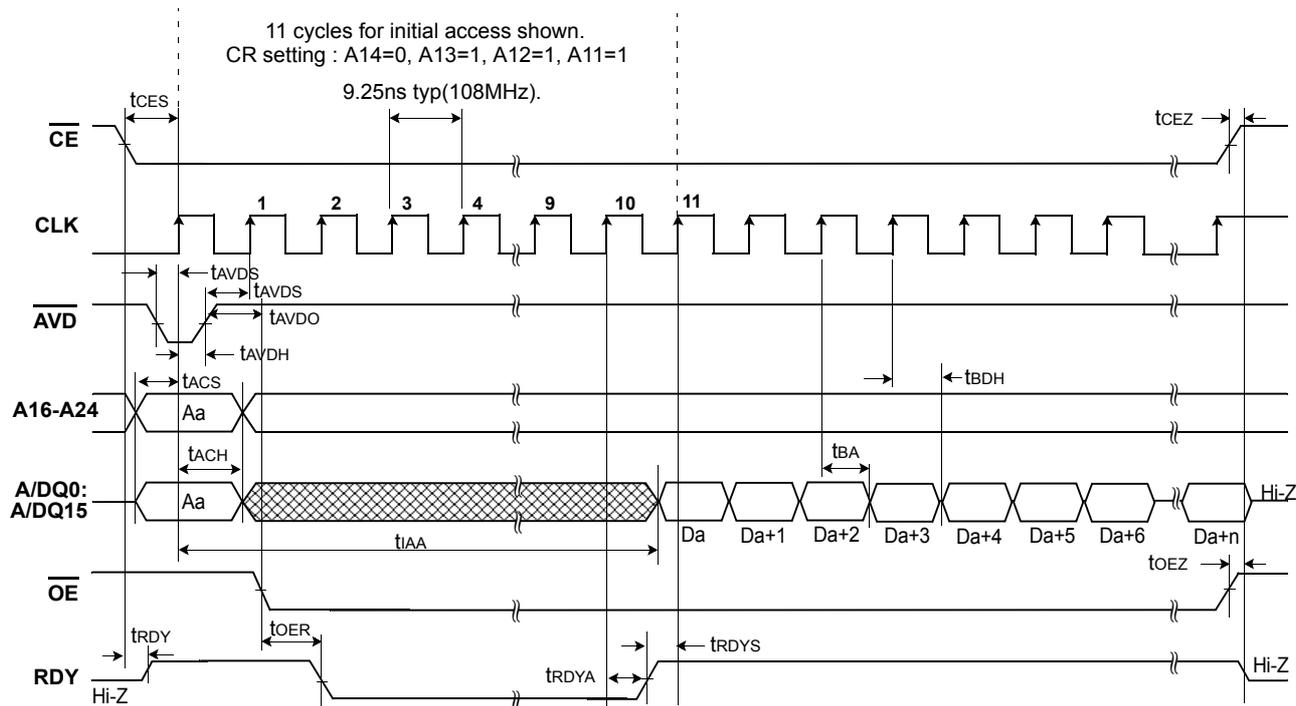

Figure 6. Continuous Burst Mode Read (108 MHz)

NOTE : In order to avoid a bus conflict the OE signal is enabled on the next rising edge after AVD is going high.

SWITCHING WAVEFORMS

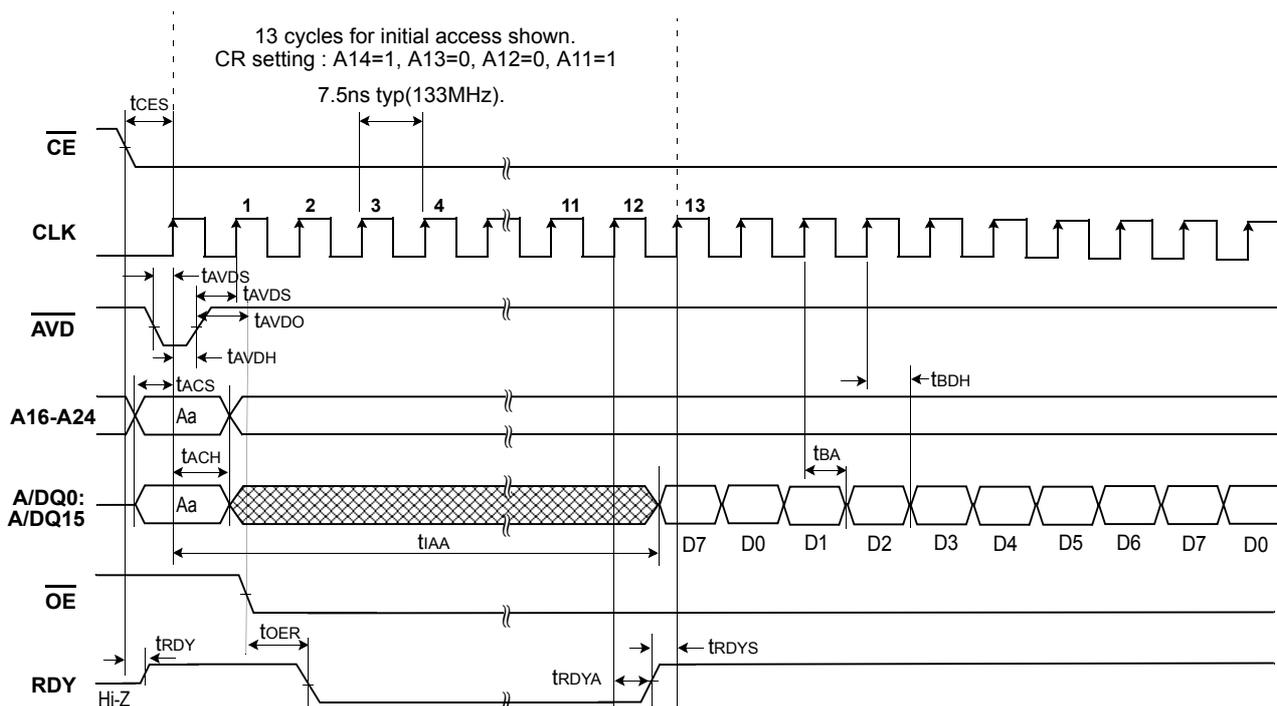

Figure 7. 8 word Linear Burst Mode with Wrap Around (133 MHz)

NOTE : In order to avoid a bus conflict the \overline{OE} signal is enabled on the next rising edge after \overline{AVD} is going high.

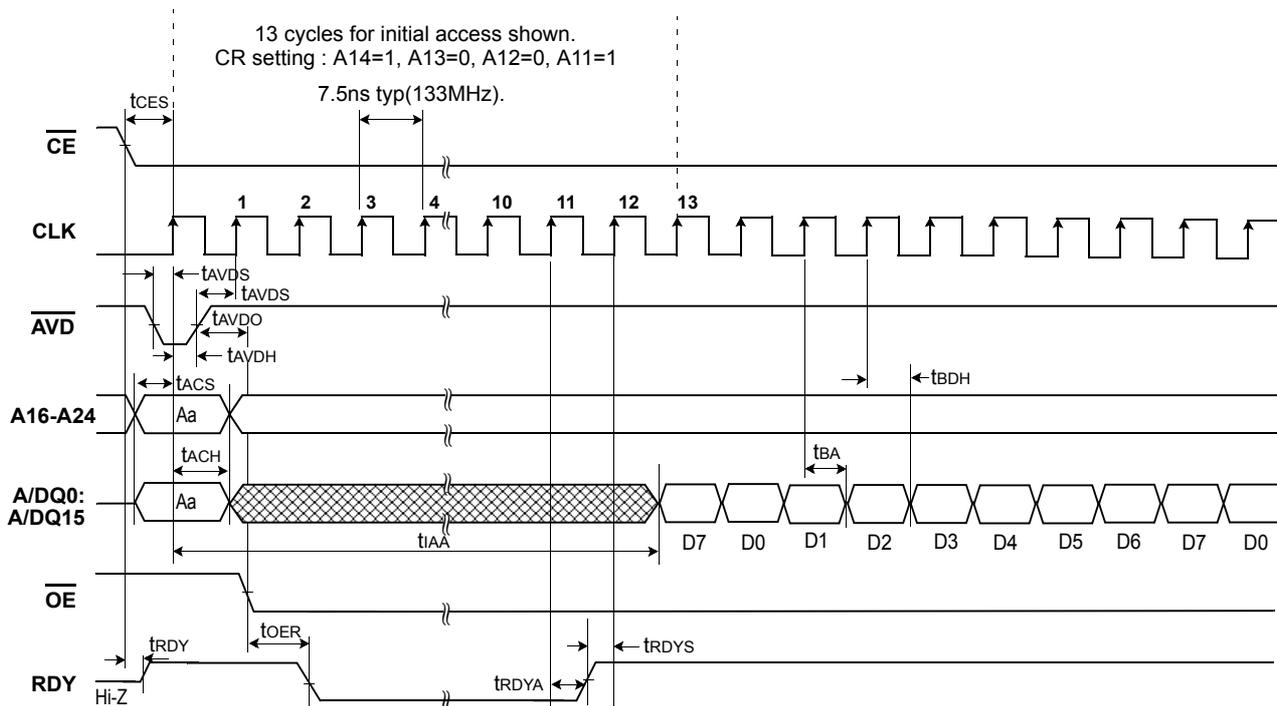

Figure 8. 8 word Linear Burst with RDY Set One Cycle Before Data (Wrap Around Mode, CR setting : A18=1)

NOTE : In order to avoid a bus conflict the \overline{OE} signal is enabled on the next rising edge after \overline{AVD} is going high.

SWITCHING WAVEFORMS

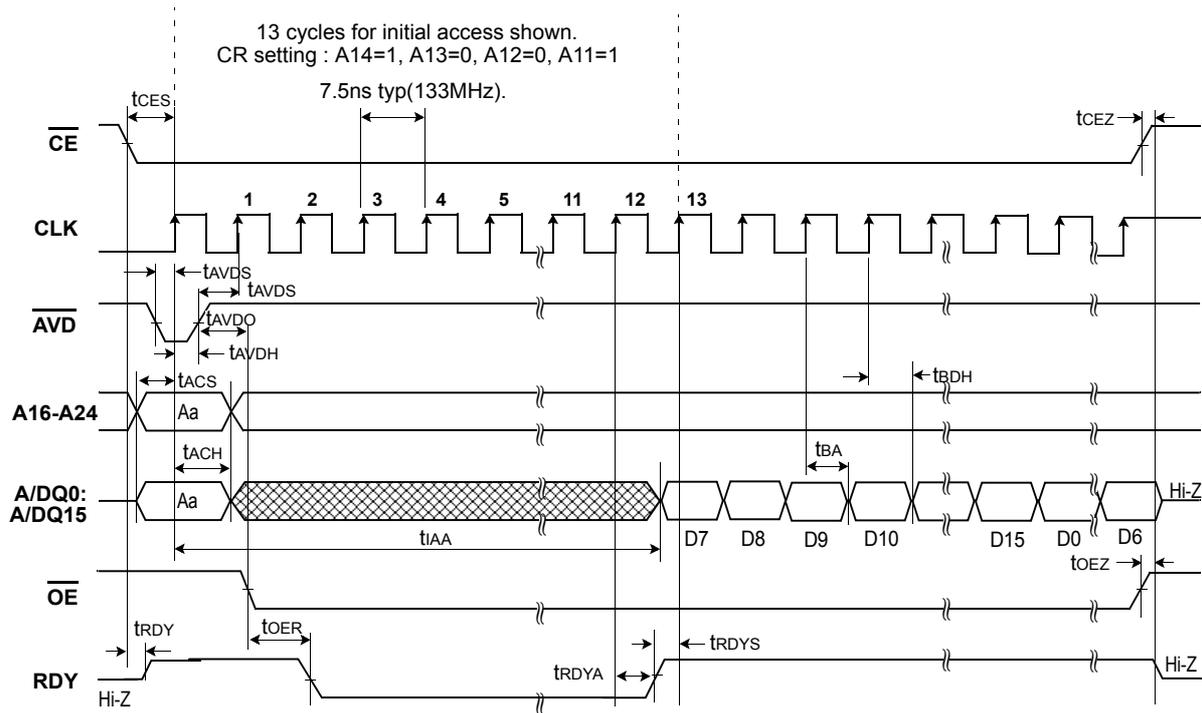

Figure 9. 16 word Linear Burst Mode with Wrap Around (133Mhz)

NOTE: In order to avoid a bus conflict the OE signal is enabled on the next rising edge after AVD is going high.

19.2 Asynchronous Read

Parameter	Symbol	All speed		Unit
		Min	Max	
Access Time from \overline{CE} Low	t_{CE}	-	100	ns
Asynchronous Access Time	t_{AA}	-	100	ns
\overline{AVD} Low time	t_{AVDP}	12	-	ns
Address Setup Time to rising Edge of \overline{AVD}	t_{AAVDS}	5	-	ns
Address Hold Time from Rising Edge of \overline{AVD}	t_{AAVDH}	2	-	ns
Output Enable to Output Valid	t_{OE}	-	15	ns
Output Enable Hold Time	Read	0	-	ns
	Toggle and \overline{Data} Polling	10	-	ns
Output Disable to High Z*	t_{OEZ}	-	9	ns

NOTE: Not 100% tested.

SWITCHING WAVEFORMS

Asynchronous Mode Read (t_{CE})

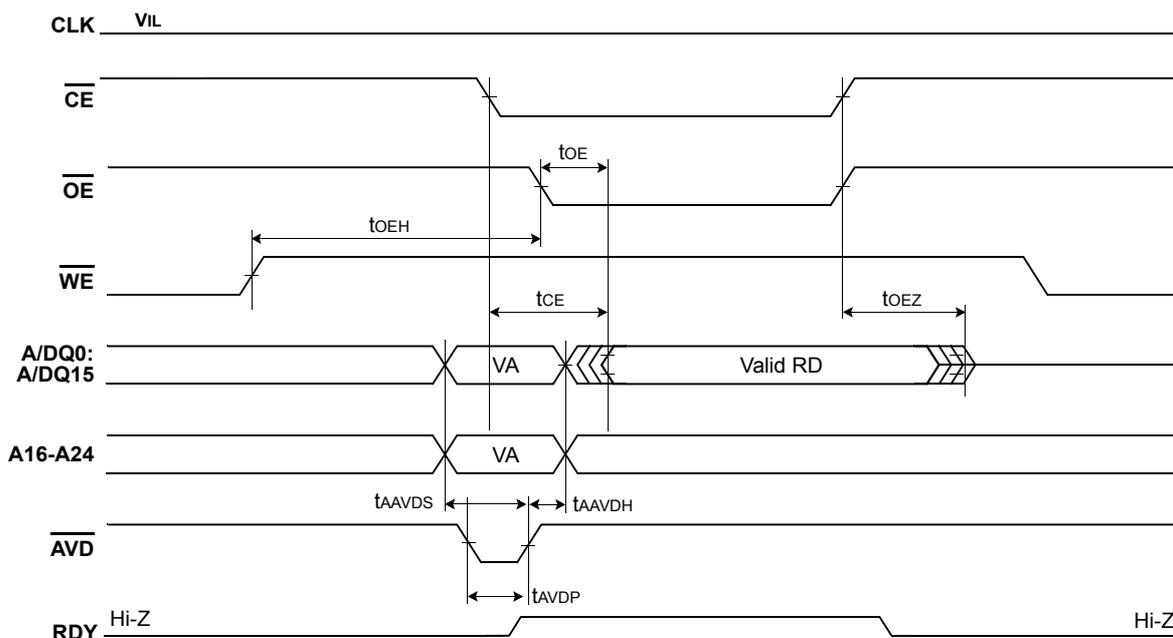

Figure 10. Asynchronous Mode Read (t_{CE})

NOTE :

- 1) VA=Valid Read Address, RD=Read Data.
Asynchronous mode may not support read following four sequential invalid read condition within 200ns.
- 2) CLK "HIGH" should be prohibited in asynchronous read mode start (From CE LOW).

Asynchronous Mode Read (tAA)

Case 1 : Valid Address Transition occurs before \overline{AVD} is driven to Low

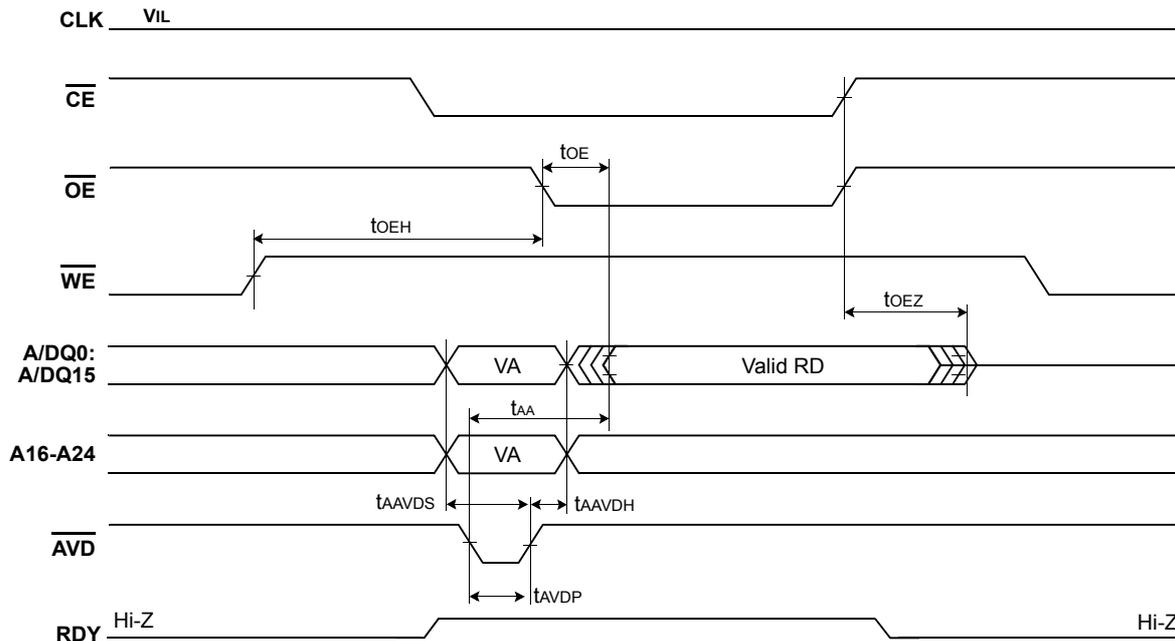

Case 2 : Valid Address Transition occurs after \overline{AVD} is driven to Low

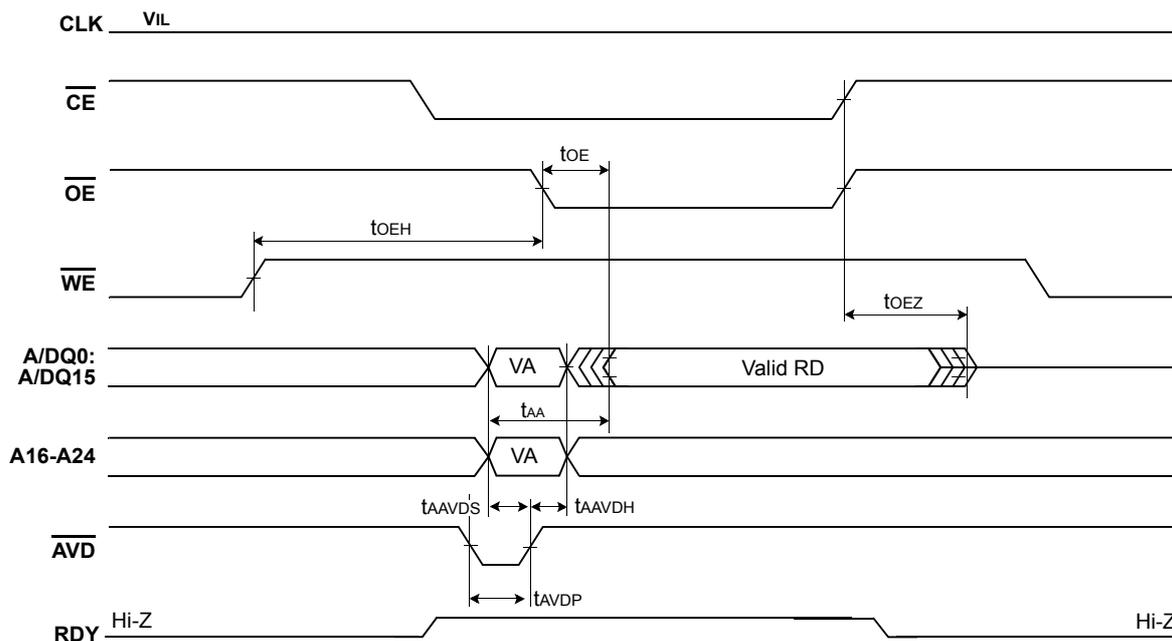

Figure 11. Asynchronous Mode Read (tAA)

NOTE :

- 1) VA=Valid Read Address, RD=Read Data.
- 2) Asynchronous mode may not support read following four sequential invalid read condition within 200ns.
- 3) CLK "HIGH" should be prohibited in asynchronous read mode start (From CE LOW).

19.3 Hardware Reset(RESET)

Parameter	Symbol	All Speed Options		Unit
		Min	Max	
RESET Pin Low(During Internal Routines) to Read Mode*	t_{Ready}	-	20	μs
RESET Pin Low(NOT During Internal Routines) to Read Mode*	t_{Ready}	-	500	ns
RESET Pulse Width	t_{RP}	200	-	ns
Reset High Time Before Read*	t_{RH}	200	-	ns

NOTE : Not 100% tested.

SWITCHING WAVEFORMS

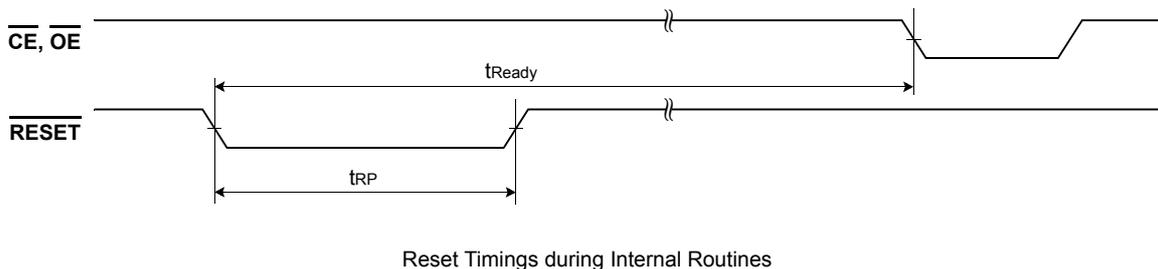
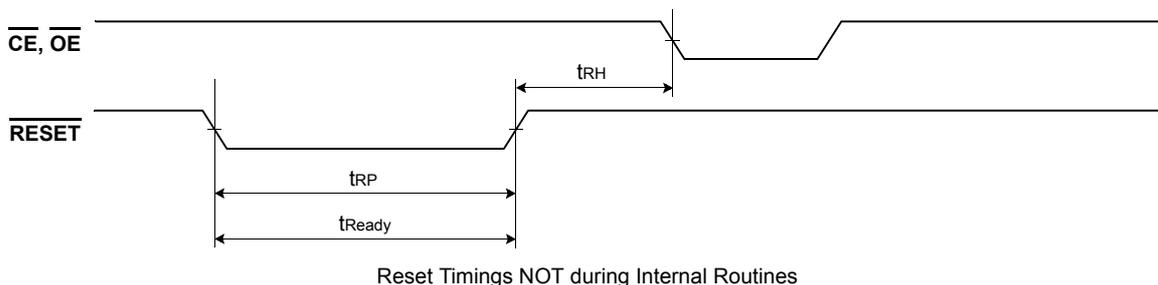

Figure 12. Reset Timings

19.4 Erase/Program Operation

Parameter	Symbol	All speed options			Unit
		Min	Typ	Max	
\overline{WE} Cycle Time ¹⁾	t_{WC}	75	-	-	ns
Address Setup Time	t_{AS}	5	-	-	ns
Address Hold Time	t_{AH}	2	-	-	ns
\overline{AVD} Low Time	t_{AVDP}	12	-	-	ns
Data Setup Time	t_{DS}	30	-	-	ns
Data Hold Time	t_{DH}	0	-	-	ns
Read Recovery Time Before Write	t_{GHWL}	0	-	-	ns
\overline{CE} Setup Time	t_{CS}	0	-	-	ns
\overline{CE} Hold Time	t_{CH}	0	-	-	ns
\overline{WE} High to \overline{AVD} low	t_{WEA}	30	-	-	ns
\overline{WE} Pulse Width	t_{WP}	30	-	-	ns
\overline{WE} Pulse Width High	t_{WPH}	45	-	-	ns
Latency Between Read and Write Operations	$t_{SR/W}$	0	-	-	ns
Word Programming Operation ²⁾	t_{PGM}	-	80	-	μ s
Single word Buffer Program ²⁾	t_{PGM_BP}	-	250	-	μ s
512-word Buffer Program ⁴⁾	t_{PGM_BP}	-	716.8	-	μ s
Accelerated Programming Operation ³⁾	t_{ACCPGM}	-	80	-	μ s
Accelerated Single word Buffer Program ³⁾	t_{ACCPGM_BP}	-	0.7	-	μ s
Accelerated 512-word Buffer Program ⁴⁾	t_{ACCPGM_BP}	-	358.4	-	μ s
Block Erase Operation (64KW block)	t_{BERS}	-	0.6	-	sec
Blank check Operation (64KW block)	t_{BLANK}	-	7	-	ms
VPP Rise and Fall Time	t_{VPP}	500	-	-	ns
VPP Setup Time (During Accelerated Programming)	t_{VPS}	1	-	-	μ s

NOTE :

1) Not 100% tested.

2) Internal programming algorithm is optimized for Buffer Program, so Normal word programming or Single word Buffer Program use Buffer Program algorithm.

3) Internal programming algorithm for supporting Accelerated mode uses a method to double the number of words programmed simultaneously.

4) Typical 512-word Buffer Program time pays due regard to that Each program data pattern ("11", "10", "01", "00") has a same portion in 512-word Buffer.

19.5 Erase/Program Performance

Parameter		Limits			Unit	Comments
		Min.	Typ.	Max.		
Block Erase Time	64 Kword	-	0.6	3.0	sec	Includes 00h programming prior to erasure
	16 Kword	-	0.3	1.5		
Chip Erase Time ³⁾		-	307.8	1539		
Accelerated Block Erase Time	64 Kword	-	0.4	3.0		
	16 Kword	-	0.2	1.5		
Accelerated Chip Erase Time ³⁾		-	205.2	1026		
Word Programming Time		-	80	550	μs / word	Excludes system level overhead
512-word Buffer Programming Time		-	1.4	7		
Accelerated Word Programming Time		-	80	550		
Accelerated 512-word Buffer Programming Time		-	0.7	3.5		
Chip Buffer Programming Time		-	46.9	234.5	sec	
Accelerated Buffer Chip Programming Time		-	23.4	117		
Blank check time		-	7	-	ms	

NOTE :

1) 25°C, VCC = 1.8V, 100,000 cycles, typical pattern.

2) System-level overhead is defined as the time required to execute the two or four bus cycle command necessary to program each word.

3) Chip Erase time & Accel. Chip Erase time for boot block part : K8S(10/11/12/13)15ET(B)C

SWITCHING WAVEFORMS
Program Operations

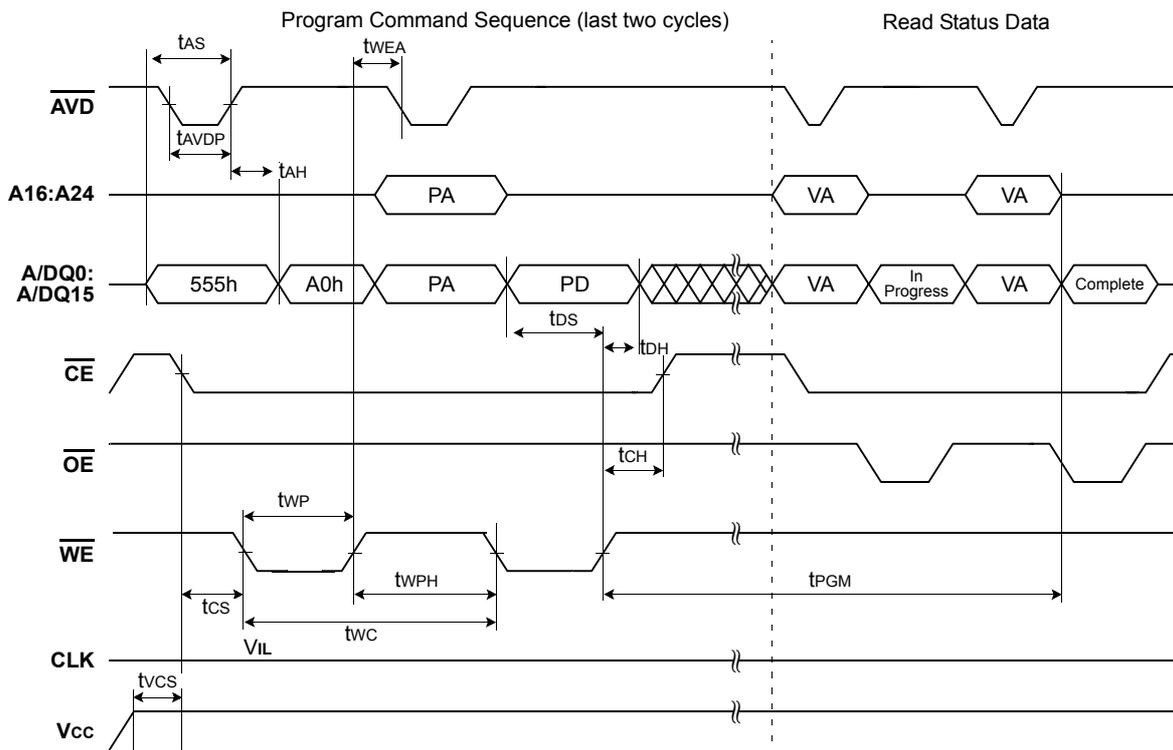

- NOTE :**
- 1) PA = Program Address, PD = Program Data, VA = Valid Address for reading status bits.
 - 2) "In progress" and "complete" refer to status of program operation.
 - 3) A16–A24 are don't care during command sequence unlock cycles.
 - 4) Status reads in this figure is asynchronous read, but status read in synchronous mode is also supported.

Figure 13. Program Operation Timing

SWITCHING WAVEFORMS
Buffer Program Operations

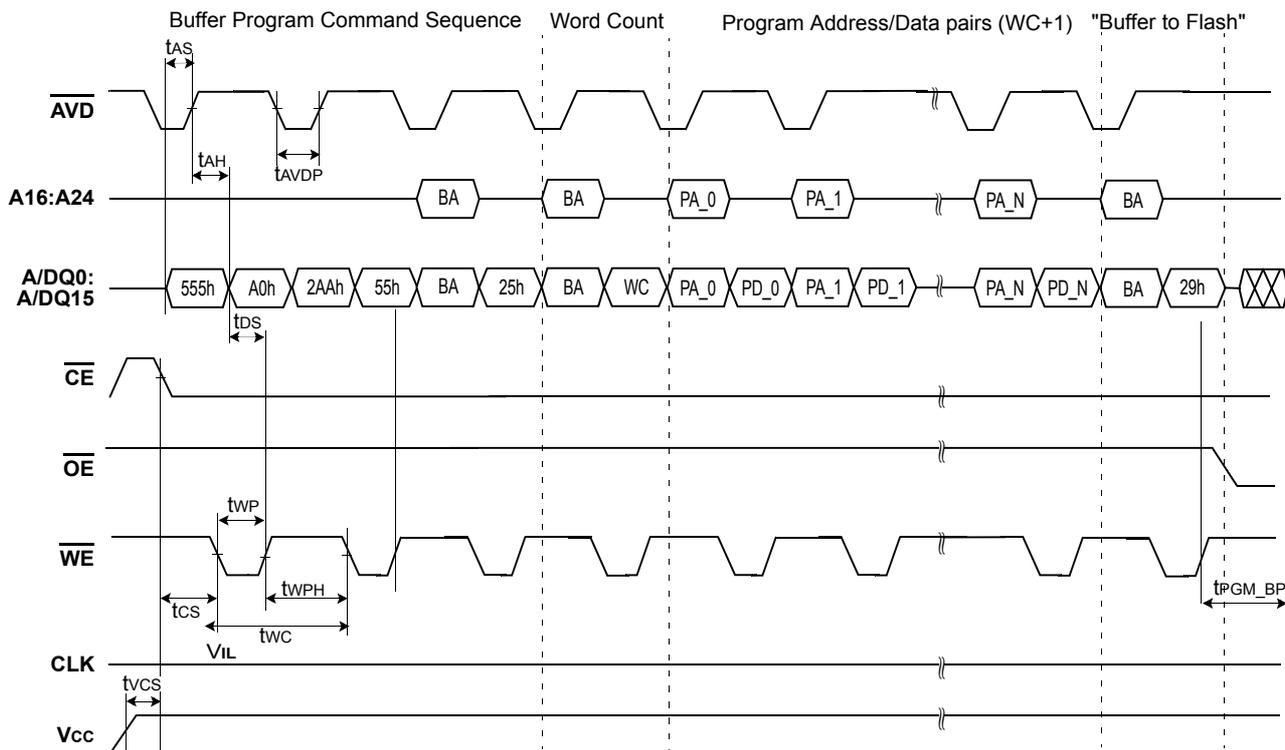

- NOTE :**
- 1) BA = Block Address, WC = Word Count, PA = Program Address, PD = Program Data, VA = Valid Address for reading status bits.
 - 2) Sequential PA₁, PA₂, ..., PA_N must have same address bits A₂₄(max.) ~ A₉ as PA₀ entered firstly
 - 3) The number of Program/Data pairs entered must be same as WC+1 because WC = N.
 - 4) "In progress" and "complete" refer to status of program operation.
 - 5) A₁₆–A₂₄ are don't care during command sequence unlock cycles.
 - 6) Status reads in this figure is asynchronous read, but status read in synchronous mode is also supported.

Figure 14. Buffer Program Operation Timing

SWITCHING WAVEFORMS
Erase Operation

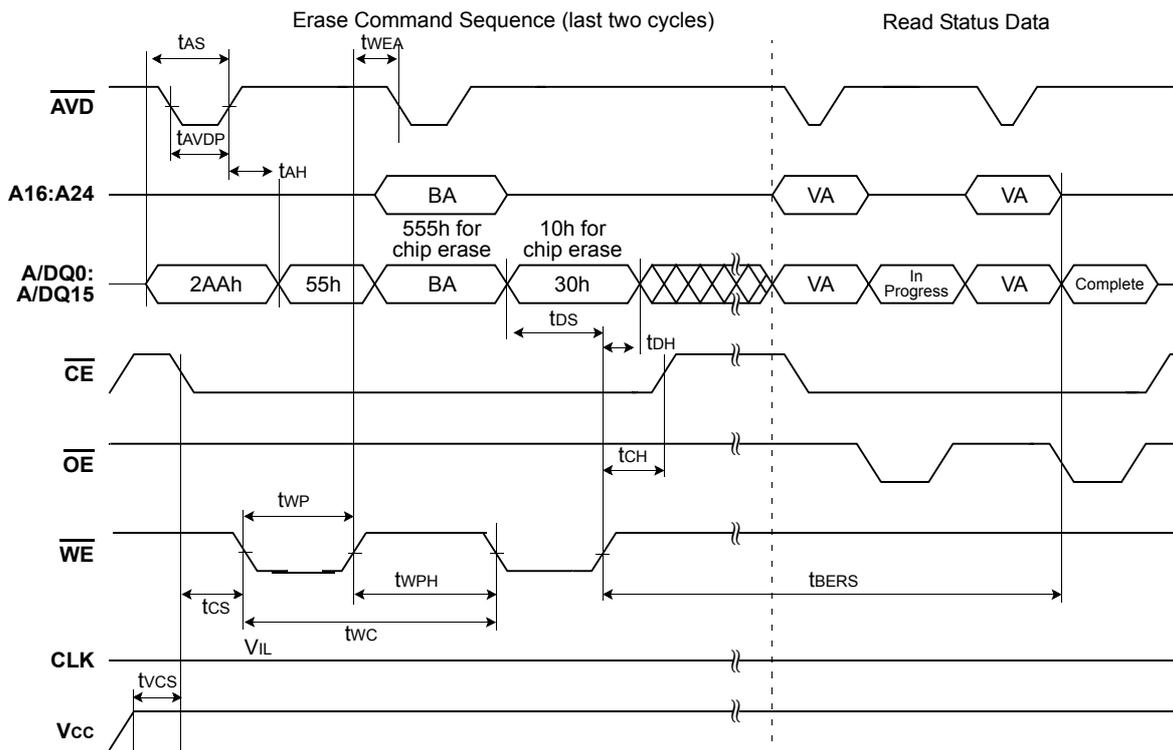

- NOTE :**
- 1) BA is the block address for Block Erase.
 - 2) Address bits A16–A24 are don't cares during unlock cycles in the command sequence.
 - 3) Status reads in this figure is asynchronous read, but status read in synchronous mode is also supported.

Figure 15. Chlp/Block Erase Operations

SWITCHING WAVEFORMS

Unlock Bypass Program Operations(Accelerated Program)

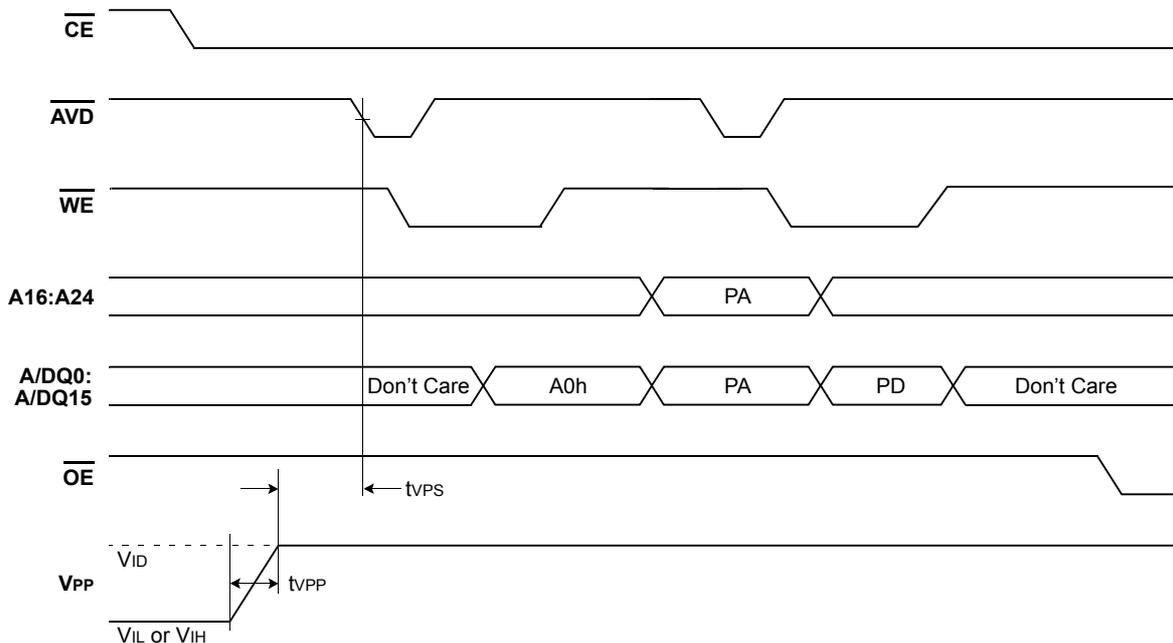

Unlock Bypass Block Erase Operations

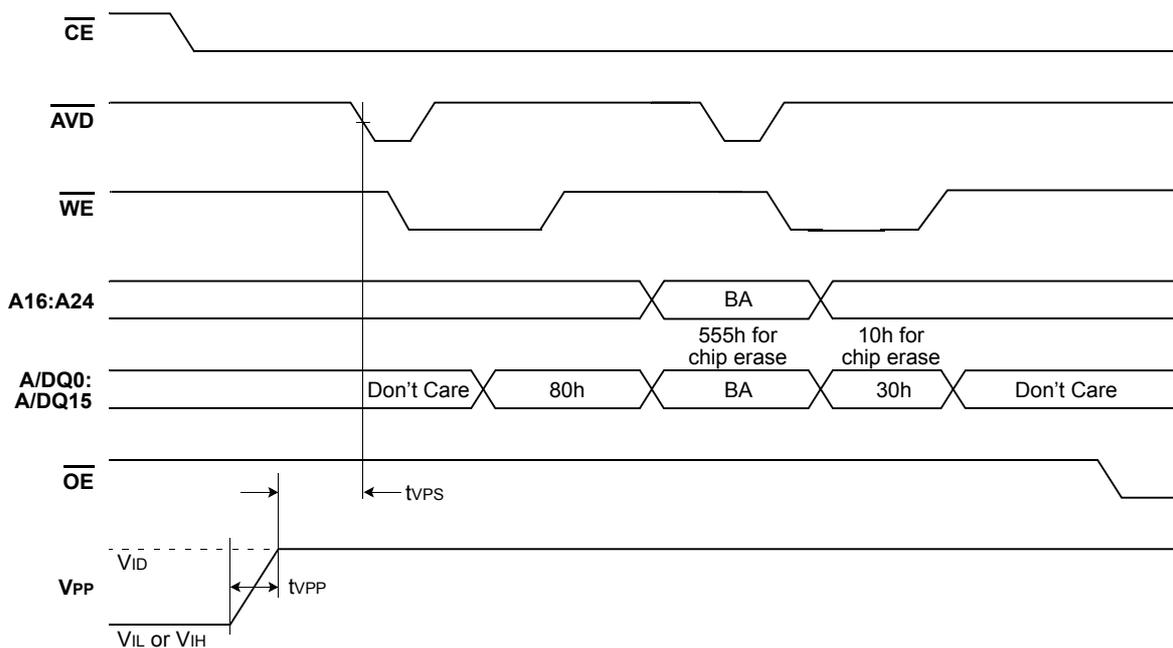

NOTE :

- 1) VPP can be left high for subsequent programming pulses.
- 2) Use setup and hold times from conventional program operations.
- 3) Conventional Program/Erase commands as well as Unlock Bypass Program/Erase commands can be used when the VID is applied to Vpp.

Figure 16. Unlock Bypass Operation Timings

SWITCHING WAVEFORMS
Data Polling Operations

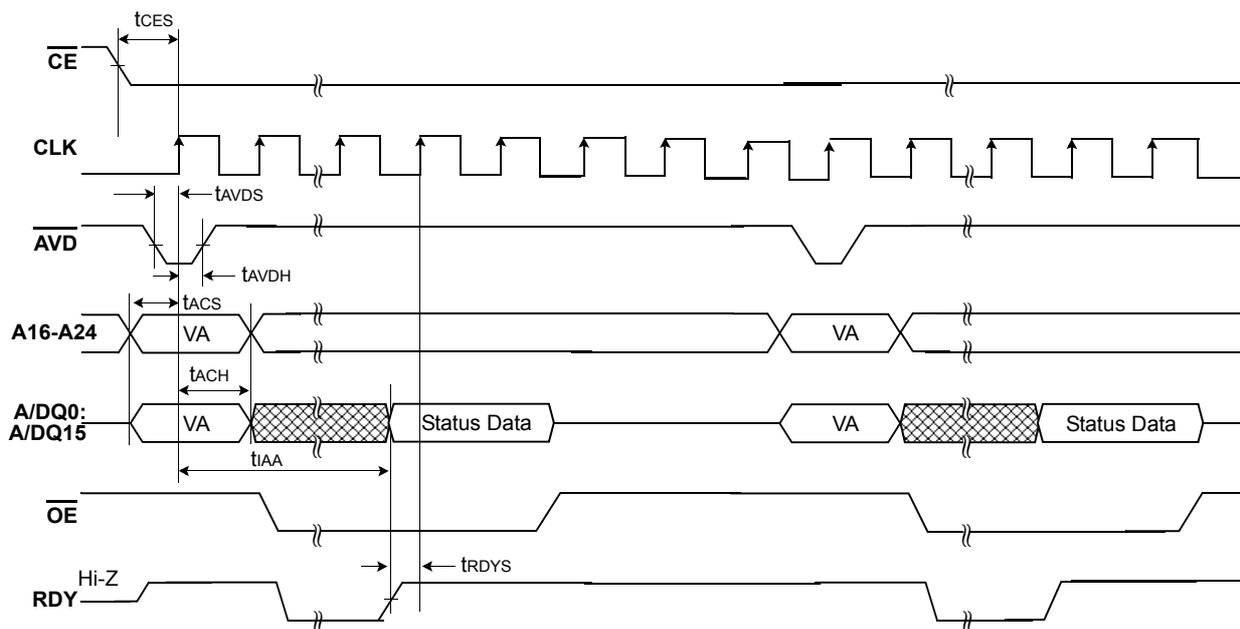

NOTE :
1) VA = Valid Address. When the Internal Routine operation is complete, and \overline{Data} Polling will output true data.

Figure 17. Data Polling Timings (During Internal Routine)

Toggle Bit Operations

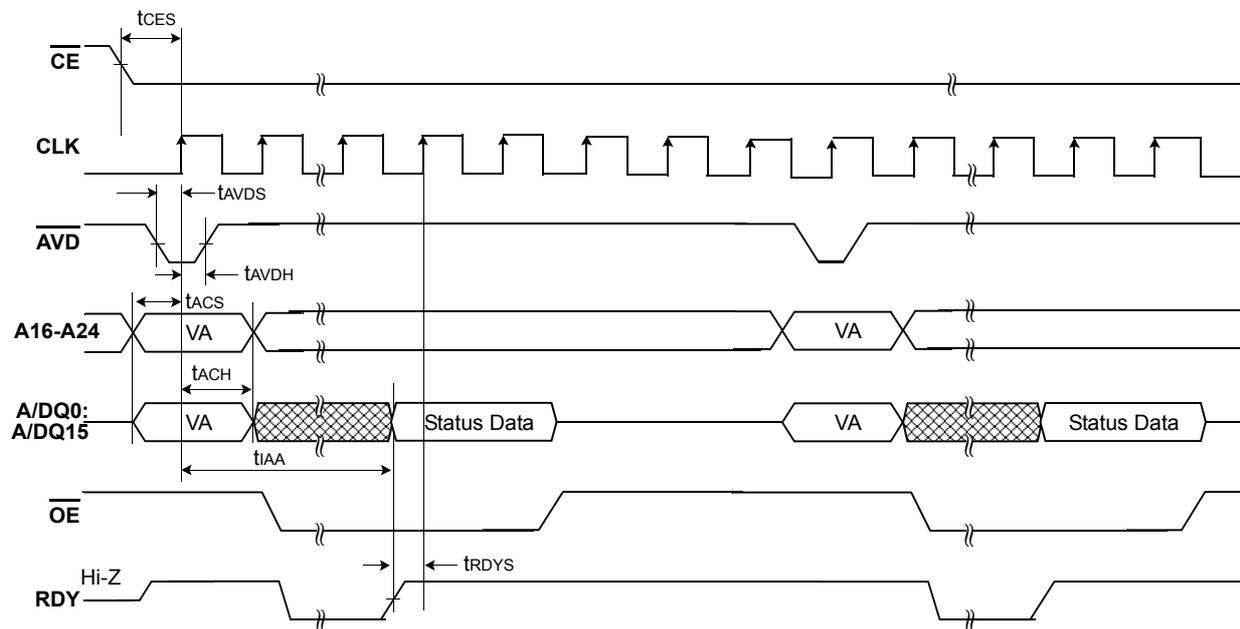

NOTE :
1) VA = Valid Address. When the Internal Routine operation is complete, the toggle bits will stop toggling.

Figure 18. Toggle Bit Timings(During Internal Routine)

SWITCHING WAVEFORMS
Read While Write Operations

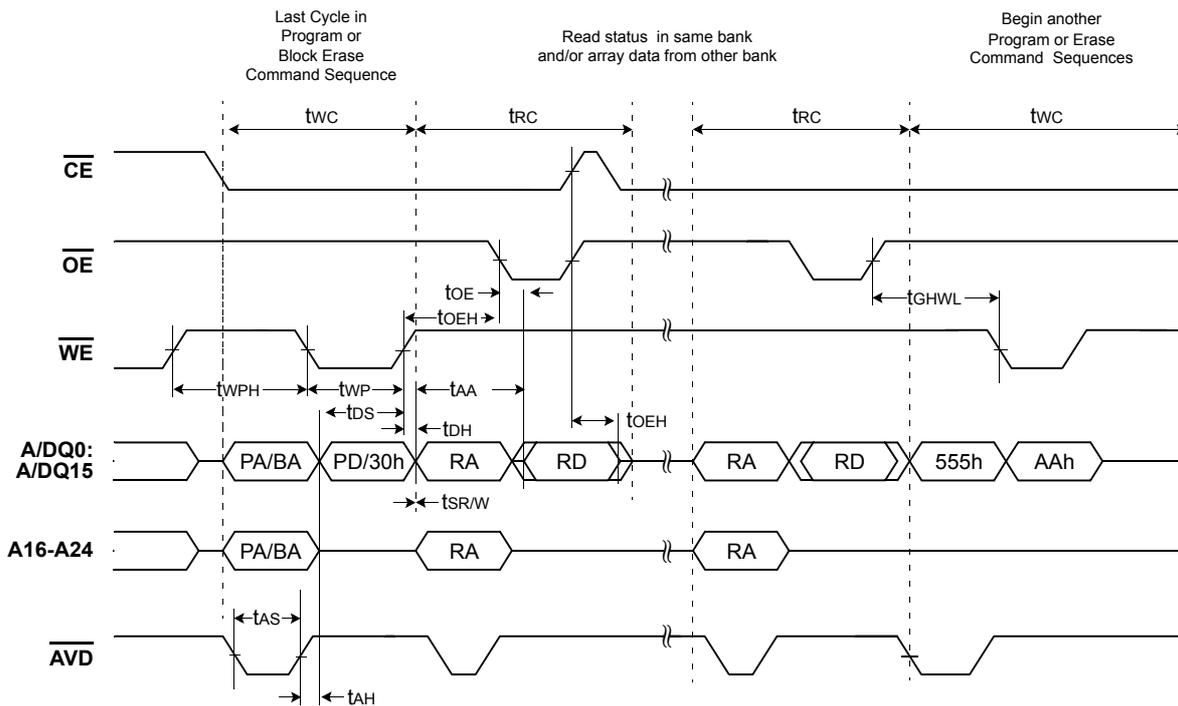

Figure 19. Read While Write Operation

NOTE :
 Breakpoints in waveforms indicate that system may alternately read array data from the "non-busy bank" and checking the status of the program or erase operation in the "busy" bank.

20.0 Crossing of First Word Boundary in Burst Read Mode

The additional clock insertion for word boundary is needed only at the first crossing of word boundary. This means that no additional clock cycle is needed from 2nd word boundary crossing to the end of continuous burst read. Also, the number of additional clock cycle for the first word boundary can vary from zero to thirteen cycles, and the exact number of additional clock cycle depends on the starting address of burst read and programmable wait state settings.

For example, if the starting address is $16N+15$ (the worst case) and programmable wait state setting(A14~A11) is "0011" (which means data is valid on the 7th active CLK edge after \overline{AVD} transition to V_{ih}), six additional clock cycle is needed.

Similarly, if the starting address is $16N+15$ (the worst case) and programmable wait state setting(A14~A11) is "0010" (which means data is valid on the 6th active CLK edge after \overline{AVD} transition to V_{ih}), five additional clock cycle is needed.

Below table shows the starting address vs. additional clock cycles for first word boundary.

Starting Address vs. Additional Clock Cycles for first word boundary

Starting Address Group for Burst Read	The Residue of (Address/16)	LSB Bits of Address	Additional Clock Cycles for First Word Boundary ¹⁾				
			A14~A11 "0000" Valid data : 4th CLK	A14~A11 "0001" Valid data : 5th CLK	A14~A11 "0010" Valid data : 6th CLK	...	A14~A11 "1010" Valid data : 14th CLK
16N	0	0000	0 cycle	0 cycle	0 cycle	...	0 cycle
16N+1	1	0001	0 cycle	0 cycle	0 cycle	...	0 cycle
16N+2	2	0010	0 cycle	0 cycle	0 cycle	...	0 cycle
16N+3	3	0011	0 cycle	0 cycle	0 cycle	...	1 cycle
16N+4	4	0100	0 cycle	0 cycle	0 cycle	...	2 cycle
16N+5	5	0101	0 cycle	0 cycle	0 cycle	...	3 cycle
16N+6	6	0110	0 cycle	0 cycle	0 cycle	...	4 cycle
16N+7	7	0111	0 cycle	0 cycle	0 cycle	...	5 cycle
16N+8	8	1000	0 cycle	0 cycle	0 cycle	...	6 cycle
16N+9	9	1001	0 cycle	0 cycle	0 cycle	...	7 cycle
16N+10	10	1010	0 cycle	0 cycle	0 cycle	...	8 cycle
16N+11	11	1011	0 cycle	0 cycle	1 cycle	...	9 cycle
16N+12	12	1100	0 cycle	1 cycle	2 cycle	...	10 cycle
16N+13	13	1101	1 cycle	2 cycle	3 cycle	...	11 cycle
16N+14	14	1110	2 cycle	3 cycle	4 cycle	...	12 cycle
16N+15	15	1111	3 cycle	4 cycle	5 cycle	...	13 cycle

NOTE :

1) Address bit A14~A11 means the programmable wait state on burst mode configuration register. Refer to Table 10.

Case 1 : Start from "16N" address group

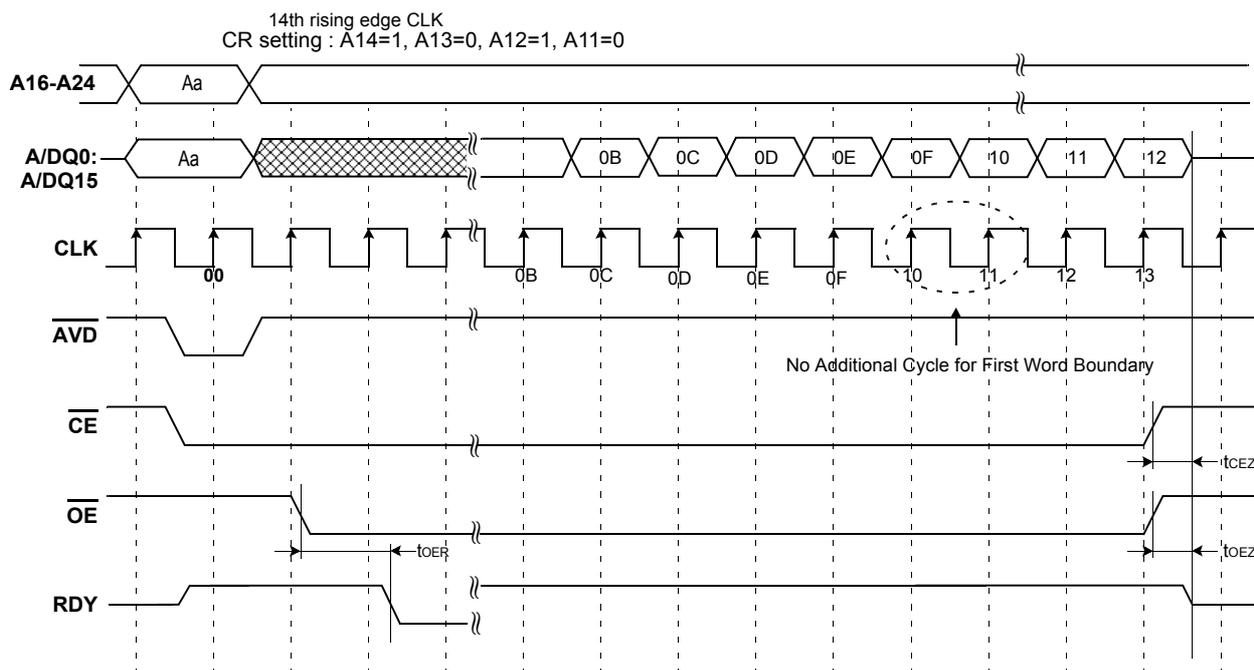

- NOTE :
- 1) Address boundary occurs every 16 words beginning at address 000000FH , 000001FH , 000002FH , etc.
 - 2) Address 000000H is also a boundary crossing.
 - 3) No additional clock cycles are needed except for 1st boundary crossing.

Figure 20. Crossing of first word boundary in burst read mode.

Case 2 : Start from "16N+3" address group

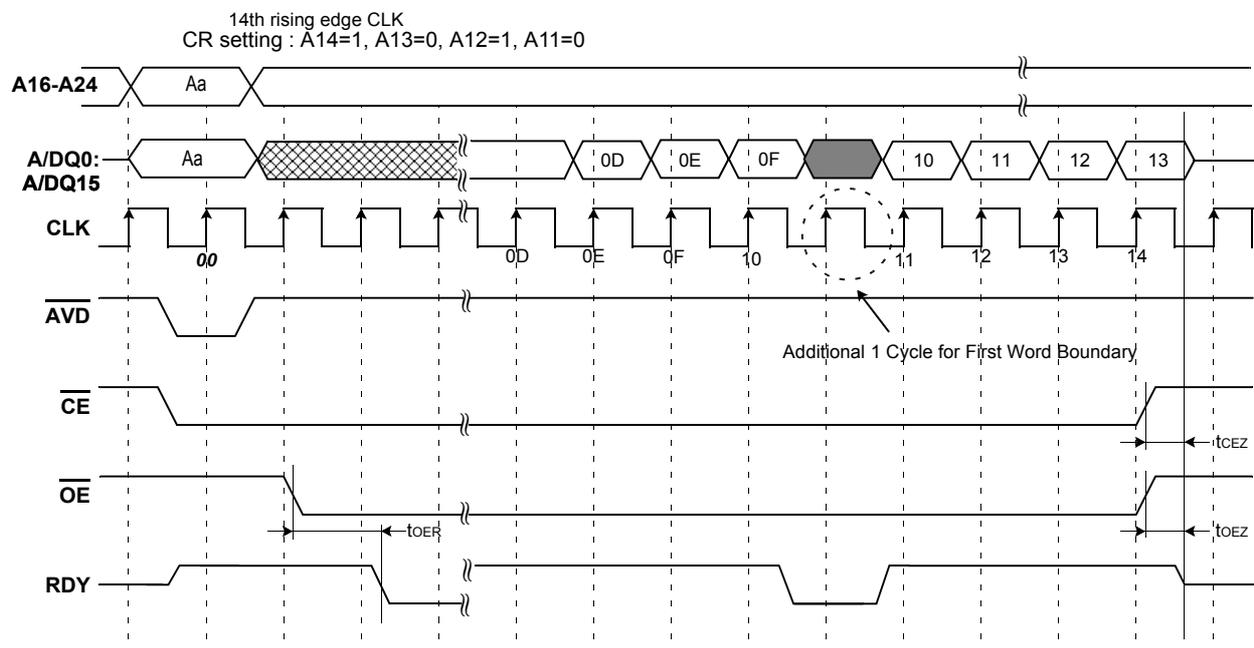

- NOTE :
- 1) Address boundary occurs every 16 words beginning at address 000000FH , 000001FH , 000002FH , etc.
 - 2) Address 000000H is also a boundary crossing.
 - 3) No additional clock cycles are needed except for 1st boundary crossing.

Figure 21. Crossing of first word boundary in burst read mode.

Case3 : Start from "16N+4" address group

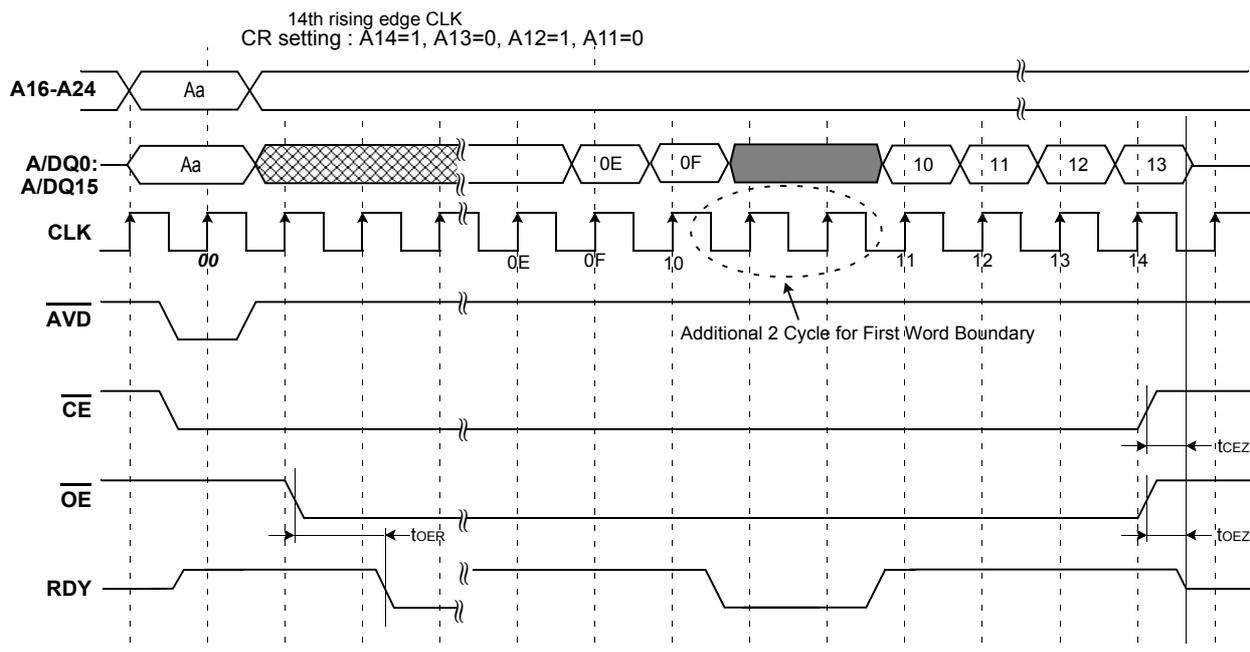

Case 4 : Start from "16N+15" address group

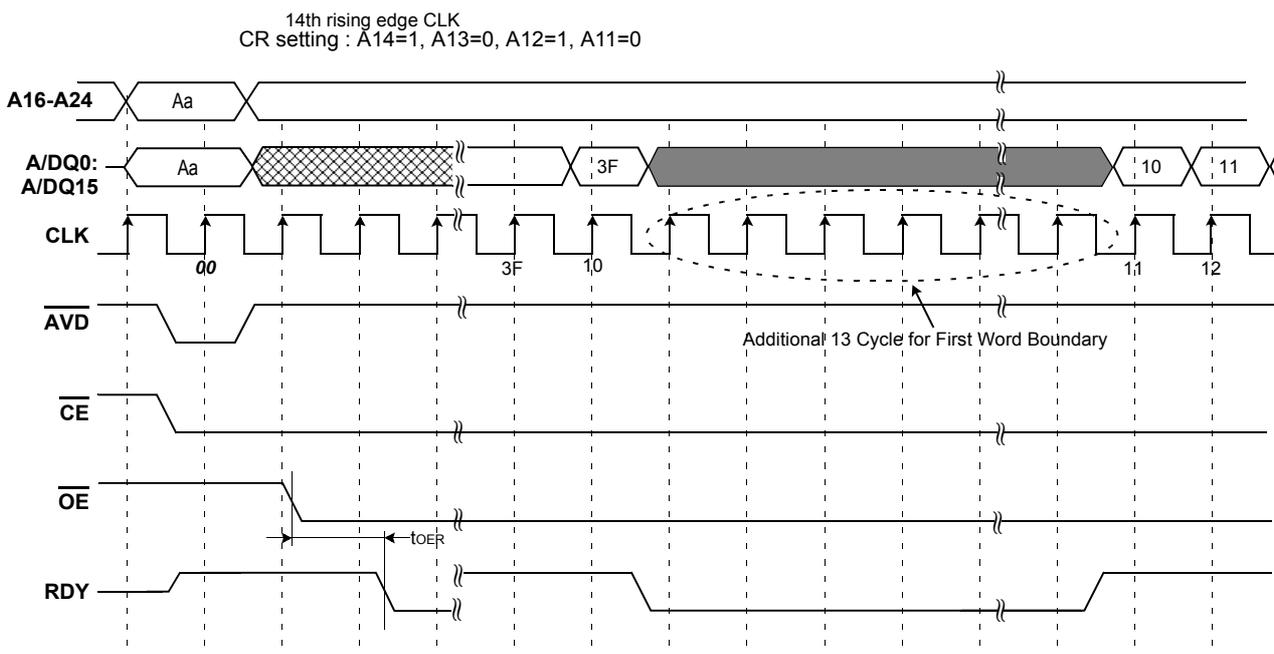

- NOTE :
- 1) Address boundary occurs every 16 words beginning at address 000000FH , 000001FH , 000002FH , etc.
 - 2) Address 000000H is also a boundary crossing.
 - 3) No additional clock cycles are needed except for 1st boundary crossing.

Figure 22. Crossing of first word boundary in burst read mode.

[Table 17] Top Boot Block Address Table

Bank	Block	Block Size	(x16) Address Range
Bank 0	BA514	16 kwords	1FFC000h-1FFFFFFh
	BA513	16 kwords	1FF8000h-1FFBFFFh
	BA512	16 kwords	1FF4000h-1FF7FFFh
	BA511	16 kwords	1FF0000h-1FF3FFFh
	BA510	64 kwords	1FE0000h-1FEFFFFh
	BA509	64 kwords	1FD0000h-1FDFFFFh
	BA508	64 kwords	1FC0000h-1FCFFFFh
	BA507	64 kwords	1FB0000h-1FBFFFFh
	BA506	64 kwords	1FA0000h-1FAFFFFh
	BA505	64 kwords	1F90000h-1F9FFFFh
	BA504	64 kwords	1F80000h-1F8FFFFh
	BA503	64 kwords	1F70000h-1F7FFFFh
	BA502	64 kwords	1F60000h-1F6FFFFh
	BA501	64 kwords	1F50000h-1F5FFFFh
	BA500	64 kwords	1F40000h-1F4FFFFh
	BA499	64 kwords	1F30000h-1F3FFFFh
	BA498	64 kwords	1F20000h-1F2FFFFh
	BA497	64 kwords	1F10000h-1F1FFFFh
	BA496	64 kwords	1F00000h-1F0FFFFh
	BA495	64 kwords	1EF0000h-1EFFFFFFh
	BA494	64 kwords	1EE0000h-1EEFFFFh
	BA493	64 kwords	1ED0000h-1EDFFFFh
	BA492	64 kwords	1EC0000h-1ECFFFFh
	BA491	64 kwords	1EB0000h-1EBFFFFh
	BA490	64 kwords	1EA0000h-1EAFFFFh
	BA489	64 kwords	1E90000h-1E9FFFFh
	BA488	64 kwords	1E80000h-1E8FFFFh
	BA487	64 kwords	1E70000h-1E7FFFFh
	BA486	64 kwords	1E60000h-1E6FFFFh
	BA485	64 kwords	1E50000h-1E5FFFFh
	BA484	64 kwords	1E40000h-1E4FFFFh
	BA483	64 kwords	1E30000h-1E3FFFFh
BA482	64 kwords	1E20000h-1E2FFFFh	
BA481	64 kwords	1E10000h-1E1FFFFh	
BA480	64 kwords	1E00000h-1E0FFFFh	
Bank 1	BA479	64 kwords	1DF0000h-1DFFFFFFh
	BA478	64 kwords	1DE0000h-1DEFFFFh
	BA477	64 kwords	1DD0000h-1DDFFFFh
	BA476	64 kwords	1DC0000h-1DCFFFFh
	BA475	64 kwords	1DB0000h-1DBFFFFh
	BA474	64 kwords	1DA0000h-1DAFFFFh
	BA473	64 kwords	1D90000h-1D9FFFFh
	BA472	64 kwords	1D80000h-1D8FFFFh
	BA471	64 kwords	1D70000h-1D7FFFFh
BA470	64 kwords	1D60000h-1D6FFFFh	

Bank	Block	Block Size	(x16) Address Range
Bank 1	BA469	64 kwords	1D50000h-1D5FFFFh
	BA468	64 kwords	1D40000h-1D4FFFFh
	BA467	64 kwords	1D30000h-1D3FFFFh
	BA466	64 kwords	1D20000h-1D2FFFFh
	BA465	64 kwords	1D10000h-1D1FFFFh
	BA464	64 kwords	1D00000h-1D0FFFFh
	BA463	64 kwords	1CF0000h-1CFFFFFh
	BA462	64 kwords	1CE0000h-1CEFFFFh
	BA461	64 kwords	1CD0000h-1CDFFFFh
	BA460	64 kwords	1CC0000h-1CCFFFFh
	BA459	64 kwords	1CB0000h-1CBFFFFh
	BA458	64 kwords	1CA0000h-1CAFFFFh
	BA457	64 kwords	1C90000h-1C9FFFFh
	BA456	64 kwords	1C80000h-1C8FFFFh
	BA455	64 kwords	1C70000h-1C7FFFFh
	BA454	64 kwords	1C60000h-1C6FFFFh
Bank 2	BA453	64 kwords	1C50000h-1C5FFFFh
	BA452	64 kwords	1C40000h-1C4FFFFh
	BA451	64 kwords	1C30000h-1C3FFFFh
	BA450	64 kwords	1C20000h-1C2FFFFh
	BA449	64 kwords	1C10000h-1C1FFFFh
	BA448	64 kwords	1C00000h-1C0FFFFh
	BA447	64 kwords	1BF0000h-1BFFFFh
	BA446	64 kwords	1BE0000h-1BEFFFFh
	BA445	64 kwords	1BD0000h-1BDFFFFh
	BA444	64 kwords	1BC0000h-1BCFFFFh
	BA443	64 kwords	1BB0000h-1BBFFFFh
	BA442	64 kwords	1BA0000h-1BAFFFFh
	BA441	64 kwords	1B90000h-1B9FFFFh
	BA440	64 kwords	1B80000h-1B8FFFFh
	BA439	64 kwords	1B70000h-1B7FFFFh
	BA438	64 kwords	1B60000h-1B6FFFFh
	BA437	64 kwords	1B50000h-1B5FFFFh
	BA436	64 kwords	1B40000h-1B4FFFFh
	BA435	64 kwords	1B30000h-1B3FFFFh
	BA434	64 kwords	1B20000h-1B2FFFFh
BA433	64 kwords	1B10000h-1B1FFFFh	
BA432	64 kwords	1B00000h-1B0FFFFh	
BA431	64 kwords	1AF0000h-1AFFFFh	
BA430	64 kwords	1AE0000h-1AEFFFFh	
BA429	64 kwords	1AD0000h-1ADFFFFh	
BA428	64 kwords	1AC0000h-1ACFFFFh	
BA427	64 kwords	1AB0000h-1ABFFFFh	
BA426	64 kwords	1AA0000h-1AAFFFFh	
BA425	64 kwords	1A90000h-1A9FFFFh	

Bank	Block	Block Size	(x16) Address Range
Bank 2	BA424	64 kwords	1A80000h-1A8FFFFh
	BA423	64 kwords	1A70000h-1A7FFFFh
	BA422	64 kwords	1A60000h-1A6FFFFh
	BA421	64 kwords	1A50000h-1A5FFFFh
	BA420	64 kwords	1A40000h-1A4FFFFh
	BA419	64 kwords	1A30000h-1A3FFFFh
	BA418	64 kwords	1A20000h-1A2FFFFh
	BA417	64 kwords	1A10000h-1A1FFFFh
Bank 3	BA416	64 kwords	1A00000h-1A0FFFFh
	BA415	64 kwords	19F0000h-19FFFFh
	BA414	64 kwords	19E0000h-19EFFFFh
	BA413	64 kwords	19D0000h-19DFFFFh
	BA412	64 kwords	19C0000h-19CFFFFh
	BA411	64 kwords	19B0000h-19BFFFFh
	BA410	64 kwords	19A0000h-19AFFFFh
	BA409	64 kwords	1990000h-199FFFFh
	BA408	64 kwords	1980000h-198FFFFh
	BA407	64 kwords	1970000h-197FFFFh
	BA406	64 kwords	1960000h-196FFFFh
	BA405	64 kwords	1950000h-195FFFFh
	BA404	64 kwords	1940000h-194FFFFh
	BA403	64 kwords	1930000h-193FFFFh
	BA402	64 kwords	1920000h-192FFFFh
	BA401	64 kwords	1910000h-191FFFFh
	BA400	64 kwords	1900000h-190FFFFh
	BA399	64 kwords	18F0000h-18FFFFh
	BA398	64 kwords	18E0000h-18EFFFFh
	BA397	64 kwords	18D0000h-18DFFFFh
	BA396	64 kwords	18C0000h-18CFFFFh
	BA395	64 kwords	18B0000h-18BFFFFh
	BA394	64 kwords	18A0000h-18AFFFFh
	BA393	64 kwords	1890000h-189FFFFh
	BA392	64 kwords	1880000h-188FFFFh
	BA391	64 kwords	1870000h-187FFFFh
	BA390	64 kwords	1860000h-186FFFFh
	BA389	64 kwords	1850000h-185FFFFh
	BA388	64 kwords	1840000h-184FFFFh
	BA387	64 kwords	1830000h-183FFFFh
	BA386	64 kwords	1820000h-182FFFFh
	BA385	64 kwords	1810000h-181FFFFh
BA384	64 kwords	1800000h-180FFFFh	
Bank 4	BA383	64 kwords	17F0000h-17FFFFh
	BA382	64 kwords	17E0000h-17EFFFFh
	BA381	64 kwords	17D0000h-17DFFFFh
	BA380	64 kwords	17C0000h-17CFFFFh

Bank	Block	Block Size	(x16) Address Range
Bank 4	BA379	64 kwords	17B0000h-17BFFFFh
	BA378	64 kwords	17A0000h-17AFFFFh
	BA377	64 kwords	1790000h-179FFFFh
	BA376	64 kwords	1780000h-178FFFFh
	BA375	64 kwords	1770000h-177FFFFh
	BA374	64 kwords	1760000h-176FFFFh
	BA373	64 kwords	1750000h-175FFFFh
	BA372	64 kwords	1740000h-174FFFFh
	BA371	64 kwords	1730000h-173FFFFh
	BA370	64 kwords	1720000h-172FFFFh
	BA369	64 kwords	1710000h-171FFFFh
	BA368	64 kwords	1700000h-170FFFFh
	BA367	64 kwords	16F0000h-16FFFFh
	BA366	64 kwords	16E0000h-16EFFFFh
	BA365	64 kwords	16D0000h-16DFFFFh
	BA364	64 kwords	16C0000h-16CFFFFh
	BA363	64 kwords	16B0000h-16BFFFFh
	BA362	64 kwords	16A0000h-16AFFFFh
	BA361	64 kwords	1690000h-169FFFFh
	BA360	64 kwords	1680000h-168FFFFh
BA359	64 kwords	1670000h-167FFFFh	
BA358	64 kwords	1660000h-166FFFFh	
BA357	64 kwords	1650000h-165FFFFh	
BA356	64 kwords	1640000h-164FFFFh	
BA355	64 kwords	1630000h-163FFFFh	
BA354	64 kwords	1620000h-162FFFFh	
BA353	64 kwords	1610000h-161FFFFh	
BA352	64 kwords	1600000h-160FFFFh	
Bank5	BA351	64 kwords	15F0000h-15FFFFh
	BA350	64 kwords	15E0000h-15EFFFFh
	BA349	64 kwords	15D0000h-15DFFFFh
	BA348	64 kwords	15C0000h-15CFFFFh
	BA347	64 kwords	15B0000h-15BFFFFh
	BA346	64 kwords	15A0000h-15AFFFFh
	BA345	64 kwords	1590000h-159FFFFh
	BA344	64 kwords	1580000h-158FFFFh
	BA343	64 kwords	1570000h-157FFFFh
	BA342	64 kwords	1560000h-156FFFFh
	BA341	64 kwords	1550000h-155FFFFh
	BA340	64 kwords	1540000h-154FFFFh
	BA339	64 kwords	1530000h-153FFFFh
	BA338	64 kwords	1520000h-152FFFFh
BA337	64 kwords	1510000h-151FFFFh	
BA336	64 kwords	1500000h-150FFFFh	

Bank	Block	Block Size	(x16) Address Range
Bank 5	BA335	64 kwords	14F0000h-14FFFFFFh
	BA334	64 kwords	14E0000h-14FFFFFFh
	BA333	64 kwords	14D0000h-14FFFFFFh
	BA332	64 kwords	14C0000h-14FFFFFFh
	BA331	64 kwords	14B0000h-14FFFFFFh
	BA330	64 kwords	14A0000h-14FFFFFFh
	BA329	64 kwords	1490000h-149FFFFFFh
	BA328	64 kwords	1480000h-148FFFFFFh
	BA327	64 kwords	1470000h-147FFFFFFh
	BA326	64 kwords	1460000h-146FFFFFFh
	BA325	64 kwords	1450000h-145FFFFFFh
	BA324	64 kwords	1440000h-144FFFFFFh
	BA323	64 kwords	1430000h-143FFFFFFh
	BA322	64 kwords	1420000h-142FFFFFFh
	BA321	64 kwords	1410000h-141FFFFFFh
BA320	64 kwords	1400000h-140FFFFFFh	
Bank 6	BA319	64 kwords	13F0000h-13FFFFFFh
	BA318	64 kwords	13E0000h-13FFFFFFh
	BA317	64 kwords	13D0000h-13DFFFFFFh
	BA316	64 kwords	13C0000h-13CFFFFFFh
	BA315	64 kwords	13B0000h-13BFFFFFFh
	BA314	64 kwords	13A0000h-13AFFFFFFh
	BA313	64 kwords	1390000h-139FFFFFFh
	BA312	64 kwords	1380000h-138FFFFFFh
	BA311	64 kwords	1370000h-137FFFFFFh
	BA310	64 kwords	1360000h-136FFFFFFh
	BA309	64 kwords	1350000h-135FFFFFFh
	BA308	64 kwords	1340000h-134FFFFFFh
	BA307	64 kwords	1330000h-133FFFFFFh
	BA306	64 kwords	1320000h-132FFFFFFh
	BA305	64 kwords	1310000h-131FFFFFFh
	BA304	64 kwords	1300000h-130FFFFFFh
	BA303	64 kwords	12F0000h-12FFFFFFh
	BA302	64 kwords	12E0000h-12FFFFFFh
	BA301	64 kwords	12D0000h-12DFFFFFFh
	BA300	64 kwords	12C0000h-12CFFFFFFh
	BA299	64 kwords	12B0000h-12BFFFFFFh
BA298	64 kwords	12A0000h-12AFFFFFFh	
BA297	64 kwords	1290000h-129FFFFFFh	
BA296	64 kwords	1280000h-128FFFFFFh	
BA295	64 kwords	1270000h-127FFFFFFh	
BA294	64 kwords	1260000h-126FFFFFFh	
BA293	64 kwords	1250000h-125FFFFFFh	
BA292	64 kwords	1240000h-124FFFFFFh	
BA291	64 kwords	1230000h-123FFFFFFh	

Bank	Block	Block Size	(x16) Address Range
Bank 6	BA290	64 kwords	1220000h-122FFFFh
	BA289	64 kwords	1210000h-121FFFFh
	BA288	64 kwords	1200000h-120FFFFh
Bank 7	BA287	64 kwords	11F0000h-11FFFFFFh
	BA286	64 kwords	11E0000h-11EFFFFh
	BA285	64 kwords	11D0000h-11DFFFFh
	BA284	64 kwords	11C0000h-11CFFFFh
	BA283	64 kwords	11B0000h-11BFFFFh
	BA282	64 kwords	11A0000h-11AFFFFh
	BA281	64 kwords	1190000h-119FFFFh
	BA280	64 kwords	1180000h-118FFFFh
	BA279	64 kwords	1170000h-117FFFFh
	BA278	64 kwords	1160000h-116FFFFh
	BA277	64 kwords	1150000h-115FFFFh
	BA276	64 kwords	1140000h-114FFFFh
	BA275	64 kwords	1130000h-113FFFFh
	BA274	64 kwords	1120000h-112FFFFh
	BA273	64 kwords	1110000h-111FFFFh
	BA272	64 kwords	1100000h-110FFFFh
	BA271	64 kwords	10F0000h-10FFFFFFh
	BA270	64 kwords	10E0000h-10EFFFFh
	BA269	64 kwords	10D0000h-10DFFFFh
	BA268	64 kwords	10C0000h-10CFFFFh
	BA267	64 kwords	10B0000h-10BFFFFh
	BA266	64 kwords	10A0000h-10AFFFFh
	BA265	64 kwords	1090000h-109FFFFh
	BA264	64 kwords	1080000h-108FFFFh
	BA263	64 kwords	1070000h-107FFFFh
	BA262	64 kwords	1060000h-106FFFFh
BA261	64 kwords	1050000h-105FFFFh	
BA260	64 kwords	1040000h-104FFFFh	
BA259	64 kwords	1030000h-103FFFFh	

Bank	Block	Block Size	(x16) Address Range
Bank 7	BA258	64 kwords	1020000h-102FFFFh
	BA257	64 kwords	1010000h-101FFFFh
	BA256	64 kwords	1000000h-100FFFFh
Bank 8	BA255	64 kwords	0FF0000h-0FFFFFFh
	BA254	64 kwords	0FE0000h-0FEFFFFh
	BA253	64 kwords	0FD0000h-0FDFFFFh
	BA252	64 kwords	0FC0000h-0FCFFFFh
	BA251	64 kwords	0FB0000h-0FBFFFFh
	BA250	64 kwords	0FA0000h-0FAFFFFh
	BA249	64 kwords	0F90000h-0F9FFFFh
	BA248	64 kwords	0F80000h-0F8FFFFh
	BA247	64 kwords	0F70000h-0F7FFFFh
	BA246	64 kwords	0F60000h-0F6FFFFh
	BA245	64 kwords	0F50000h-0F5FFFFh
	BA244	64 kwords	0F40000h-0F4FFFFh
	BA243	64 kwords	0F30000h-0F3FFFFh
	BA242	64 kwords	0F20000h-0F2FFFFh
	BA241	64 kwords	0F10000h-0F1FFFFh
	BA240	64 kwords	0F00000h-0F0FFFFh
	BA239	64 kwords	0EF0000h-0EFFFFFFh
	BA238	64 kwords	0EE0000h-0EEFFFFh
	BA237	64 kwords	0ED0000h-0EDFFFFh
	BA236	64 kwords	0EC0000h-0ECFFFFh
	BA235	64 kwords	0EB0000h-0EBFFFFh
	BA234	64 kwords	0EA0000h-0EAFFFFh
	BA233	64 kwords	0E90000h-0E9FFFFh
	BA232	64 kwords	0E80000h-0E8FFFFh
	BA231	64 kwords	0E70000h-0E7FFFFh
	BA230	64 kwords	0E60000h-0E6FFFFh
	BA229	64 kwords	0E50000h-0E5FFFFh
BA228	64 kwords	0E40000h-0E4FFFFh	
BA227	64 kwords	0E30000h-0E3FFFFh	
BA226	64 kwords	0E20000h-0E2FFFFh	
BA225	64 kwords	0E10000h-0E1FFFFh	
BA224	64 kwords	0E00000h-0E0FFFFh	
Bank 9	BA223	64 kwords	0DF0000h-0DFFFFFFh
	BA222	64 kwords	0DE0000h-0DEFFFFh
	BA221	64 kwords	0DD0000h-0DDFFFFh
	BA220	64 kwords	0DC0000h-0DCFFFFh
	BA219	64 kwords	0DB0000h-0DBFFFFh
	BA218	64 kwords	0DA0000h-0DAFFFFh
	BA217	64 kwords	0D90000h-0D9FFFFh
	BA216	64 kwords	0D80000h-0D8FFFFh
	BA215	64 kwords	0D70000h-0D7FFFFh
BA214	64 kwords	0D60000h-0D6FFFFh	

Bank	Block	Block Size	(x16) Address Range
Bank 9	BA213	64 kwords	0D50000h-0D5FFFFh
	BA212	64 kwords	0D40000h-0D4FFFFh
	BA211	64 kwords	0D30000h-0D3FFFFh
	BA210	64 kwords	0D20000h-0D2FFFFh
	BA209	64 kwords	0D10000h-0D1FFFFh
	BA208	64 kwords	0D00000h-0D0FFFFh
	BA207	64 kwords	0CF0000h-0CFFFFFh
	BA206	64 kwords	0CE0000h-0CEFFFFh
	BA205	64 kwords	0CD0000h-0CDFFFFh
	BA204	64 kwords	0CC0000h-0CCFFFFh
	BA203	64 kwords	0CB0000h-0CBFFFFh
	BA202	64 kwords	0CA0000h-0CAFFFFh
	BA201	64 kwords	0C90000h-0C9FFFFh
	BA200	64 kwords	0C80000h-0C8FFFFh
	BA199	64 kwords	0C70000h-0C7FFFFh
	BA198	64 kwords	0C60000h-0C6FFFFh
Bank 10	BA197	64 kwords	0C50000h-0C5FFFFh
	BA196	64 kwords	0C40000h-0C4FFFFh
	BA195	64 kwords	0C30000h-0C3FFFFh
	BA194	64 kwords	0C20000h-0C2FFFFh
	BA193	64 kwords	0C10000h-0C1FFFFh
	BA192	64 kwords	0C00000h-0C0FFFFh
	BA191	64 kwords	0BF0000h-0BFFFFFh
	BA190	64 kwords	0BE0000h-0BEFFFFh
	BA189	64 kwords	0BD0000h-0BDFFFFh
	BA188	64 kwords	0BC0000h-0BCFFFFh
	BA187	64 kwords	0BB0000h-0BBFFFFh
	BA186	64 kwords	0BA0000h-0BAFFFFh
	BA185	64 kwords	0B90000h-0B9FFFFh
	BA184	64 kwords	0B80000h-0B8FFFFh
	BA183	64 kwords	0B70000h-0B7FFFFh
	BA182	64 kwords	0B60000h-0B6FFFFh
BA181	64 kwords	0B50000h-0B5FFFFh	
BA180	64 kwords	0B40000h-0B4FFFFh	
BA179	64 kwords	0B30000h-0B3FFFFh	
BA178	64 kwords	0B20000h-0B2FFFFh	
BA177	64 kwords	0B10000h-0B1FFFFh	
BA176	64 kwords	0B00000h-0B0FFFFh	
BA175	64 kwords	0AF0000h-0AFFFFFh	
BA174	64 kwords	0AE0000h-0AEFFFFh	
BA173	64 kwords	0AD0000h-0ADFFFFh	
BA172	64 kwords	0AC0000h-0ACFFFFh	
BA171	64 kwords	0AB0000h-0ABFFFFh	
BA170	64 kwords	0AA0000h-0AAFFFFh	
BA169	64 kwords	0A90000h-0A9FFFFh	

Bank	Block	Block Size	(x16) Address Range
Bank 10	BA168	64 kwords	0A80000h-0A8FFFFh
	BA167	64 kwords	0A70000h-0A7FFFFh
	BA166	64 kwords	0A60000h-0A6FFFFh
	BA165	64 kwords	0A50000h-0A5FFFFh
	BA164	64 kwords	0A40000h-0A4FFFFh
	BA163	64 kwords	0A30000h-0A3FFFFh
	BA162	64 kwords	0A20000h-0A2FFFFh
	BA161	64 kwords	0A10000h-0A1FFFFh
Bank 11	BA160	64 kwords	0A00000h-0A0FFFFh
	BA159	64 kwords	09F0000h-09FFFFh
	BA158	64 kwords	09E0000h-09EFFFFh
	BA157	64 kwords	09D0000h-09DFFFFh
	BA156	64 kwords	09C0000h-09CFFFFh
	BA155	64 kwords	09B0000h-09BFFFFh
	BA154	64 kwords	09A0000h-09AFFFFh
	BA153	64 kwords	0990000h-099FFFFh
	BA152	64 kwords	0980000h-098FFFFh
	BA151	64 kwords	0970000h-097FFFFh
	BA150	64 kwords	0960000h-096FFFFh
	BA149	64 kwords	0950000h-095FFFFh
	BA148	64 kwords	0940000h-094FFFFh
	BA147	64 kwords	0930000h-093FFFFh
	BA146	64 kwords	0920000h-092FFFFh
	BA145	64 kwords	0910000h-091FFFFh
	BA144	64 kwords	0900000h-090FFFFh
	BA143	64 kwords	08F0000h-08FFFFh
	BA142	64 kwords	08E0000h-08EFFFFh
	BA141	64 kwords	08D0000h-08DFFFFh
	BA140	64 kwords	08C0000h-08CFFFFh
	BA139	64 kwords	08B0000h-08BFFFFh
	BA138	64 kwords	08A0000h-08AFFFFh
	BA137	64 kwords	0890000h-089FFFFh
	BA136	64 kwords	0880000h-088FFFFh
	BA135	64 kwords	0870000h-087FFFFh
	BA134	64 kwords	0860000h-086FFFFh
	BA133	64 kwords	0850000h-085FFFFh
	BA132	64 kwords	0840000h-084FFFFh
	BA131	64 kwords	0830000h-083FFFFh
	BA130	64 kwords	0820000h-082FFFFh
	BA129	64 kwords	0810000h-081FFFFh
BA128	64 kwords	0800000h-080FFFFh	
Bank 12	BA127	64 kwords	07F0000h-07FFFFh
	BA126	64 kwords	07E0000h-07EFFFFh
	BA125	64 kwords	07D0000h-07DFFFFh
	BA124	64 kwords	07C0000h-07CFFFFh

Bank	Block	Block Size	(x16) Address Range
Bank 12	BA123	64 kwords	07B0000h-07BFFFFh
	BA122	64 kwords	07A0000h-07AFFFFh
	BA121	64 kwords	0790000h-079FFFFh
	BA120	64 kwords	0780000h-078FFFFh
	BA119	64 kwords	0770000h-077FFFFh
	BA118	64 kwords	0760000h-076FFFFh
	BA117	64 kwords	0750000h-075FFFFh
	BA116	64 kwords	0740000h-074FFFFh
	BA115	64 kwords	0730000h-073FFFFh
	BA114	64 kwords	0720000h-072FFFFh
	BA113	64 kwords	0710000h-071FFFFh
	BA112	64 kwords	0700000h-070FFFFh
	BA111	64 kwords	06F0000h-06FFFFh
	BA110	64 kwords	06E0000h-06EFFFFh
	BA109	64 kwords	06D0000h-06DFFFFh
	BA108	64 kwords	06C0000h-06CFFFFh
	BA107	64 kwords	06B0000h-06BFFFFh
	BA106	64 kwords	06A0000h-06AFFFFh
	BA105	64 kwords	0690000h-069FFFFh
	BA104	64 kwords	0680000h-068FFFFh
BA103	64 kwords	0670000h-067FFFFh	
BA102	64 kwords	0660000h-066FFFFh	
BA101	64 kwords	0650000h-065FFFFh	
BA100	64 kwords	0640000h-064FFFFh	
BA99	64 kwords	0630000h-063FFFFh	
BA98	64 kwords	0620000h-062FFFFh	
BA97	64 kwords	0610000h-061FFFFh	
BA96	64 kwords	0600000h-060FFFFh	
Bank 13	BA95	64 kwords	05F0000h-05FFFFh
	BA94	64 kwords	05E0000h-05EFFFFh
	BA93	64 kwords	05D0000h-05DFFFFh
	BA92	64 kwords	05C0000h-05CFFFFh
	BA91	64 kwords	05B0000h-05BFFFFh
	BA90	64 kwords	05A0000h-05AFFFFh
	BA89	64 kwords	0590000h-059FFFFh
	BA88	64 kwords	0580000h-058FFFFh
	BA87	64 kwords	0570000h-057FFFFh
	BA86	64 kwords	0560000h-056FFFFh
	BA85	64 kwords	0550000h-055FFFFh
	BA84	64 kwords	0540000h-054FFFFh
	BA83	64 kwords	0530000h-053FFFFh
	BA82	64 kwords	0520000h-052FFFFh
BA81	64 kwords	0510000h-051FFFFh	
BA80	64 kwords	0500000h-050FFFFh	

Bank	Block	Block Size	(x16) Address Range
Bank 13	BA79	64 kwords	04F0000h-04FFFFFFh
	BA78	64 kwords	04E0000h-04EFFFFh
	BA77	64 kwords	04D0000h-04DFFFFh
	BA76	64 kwords	04C0000h-04CFFFFh
	BA75	64 kwords	04B0000h-04BFFFFh
	BA74	64 kwords	04A0000h-04AFFFFh
	BA73	64 kwords	0490000h-049FFFFh
	BA72	64 kwords	0480000h-048FFFFh
	BA71	64 kwords	0470000h-047FFFFh
	BA70	64 kwords	0460000h-046FFFFh
	BA69	64 kwords	0450000h-045FFFFh
	BA68	64 kwords	0440000h-044FFFFh
	BA67	64 kwords	0430000h-043FFFFh
	BA66	64 kwords	0420000h-042FFFFh
	BA65	64 kwords	0410000h-041FFFFh
Bank 14	BA64	64 kwords	0400000h-040FFFFh
	BA63	64 kwords	03F0000h-03FFFFFFh
	BA62	64 kwords	03E0000h-03EFFFFh
	BA61	64 kwords	03D0000h-03DFFFFh
	BA60	64 kwords	03C0000h-03CFFFFh
	BA59	64 kwords	03B0000h-03BFFFFh
	BA58	64 kwords	03A0000h-03AFFFFh
	BA57	64 kwords	0390000h-039FFFFh
	BA56	64 kwords	0380000h-038FFFFh
	BA55	64 kwords	0370000h-037FFFFh
	BA54	64 kwords	0360000h-036FFFFh
	BA53	64 kwords	0350000h-035FFFFh
	BA52	64 kwords	0340000h-034FFFFh
	BA51	64 kwords	0330000h-033FFFFh
	BA50	64 kwords	0320000h-032FFFFh
	BA49	64 kwords	0310000h-031FFFFh
	BA48	64 kwords	0300000h-030FFFFh
	BA47	64 kwords	02F0000h-02FFFFFh
	BA46	64 kwords	02E0000h-02EFFFFh
	BA45	64 kwords	02D0000h-02DFFFFh
BA44	64 kwords	02C0000h-02CFFFFh	
BA43	64 kwords	02B0000h-02BFFFFh	
BA42	64 kwords	02A0000h-02AFFFFh	
BA41	64 kwords	0290000h-029FFFFh	
BA40	64 kwords	0280000h-028FFFFh	
BA39	64 kwords	0270000h-027FFFFh	
BA38	64 kwords	0260000h-026FFFFh	
BA37	64 kwords	0250000h-025FFFFh	
BA36	64 kwords	0240000h-024FFFFh	
BA35	64 kwords	0230000h-023FFFFh	

Bank	Block	Block Size	(x16) Address Range
Bank 14	BA34	64 kwords	0220000h-022FFFFh
	BA33	64 kwords	0210000h-021FFFFh
	BA32	64 kwords	0200000h-020FFFFh
Bank 15	BA31	64 kwords	01F0000h-01FFFFFFh
	BA30	64 kwords	01E0000h-01EFFFFh
	BA29	64 kwords	01D0000h-01DFFFFh
	BA28	64 kwords	01C0000h-01CFFFFh
	BA27	64 kwords	01B0000h-01BFFFFh
	BA26	64 kwords	01A0000h-01AFFFFh
	BA25	64 kwords	0190000h-019FFFFh
	BA24	64 kwords	0180000h-018FFFFh
	BA23	64 kwords	0170000h-017FFFFh
	BA22	64 kwords	0160000h-016FFFFh
	BA21	64 kwords	0150000h-015FFFFh
	BA20	64 kwords	0140000h-014FFFFh
	BA19	64 kwords	0130000h-013FFFFh
	BA18	64 kwords	0120000h-012FFFFh
	BA17	64 kwords	0110000h-011FFFFh
	BA16	64 kwords	0100000h-010FFFFh
	BA15	64 kwords	00F0000h-00FFFFFFh
	BA14	64 kwords	00E0000h-00EFFFFh
	BA13	64 kwords	00D0000h-00DFFFFh
	BA12	64 kwords	00C0000h-00CFFFFh
	BA11	64 kwords	00B0000h-00BFFFFh
	BA10	64 kwords	00A0000h-00AFFFFh
	BA9	64 kwords	0090000h-009FFFFh
	BA8	64 kwords	0080000h-008FFFFh
	BA7	64 kwords	0070000h-007FFFFh
	BA6	64 kwords	0060000h-006FFFFh
	BA5	64 kwords	0050000h-005FFFFh
BA4	64 kwords	0040000h-004FFFFh	
BA3	64 kwords	0030000h-003FFFFh	
BA2	64 kwords	0020000h-002FFFFh	
BA1	64 kwords	0010000h-001FFFFh	
BA0	64 kwords	0000000h-000FFFFh	

[Table 18] Top Boot OTP Block Addresses

OTP	Block Address A24 ~ A8	Block Size	(x16) Address Range*
	1FFFFh	512 words	1FFFE00h-1FFFFFFh

After entering OTP Block, any issued addresses should be in the range of OTP block address.

[Table 19] Bottom Boot Block Address Table

Bank	Block	Block Size	(x16) Address Range
Bank 15	BA514	64 Kwords	1FF0000h-1FFFFFFh
	BA513	64 Kwords	1FE0000h-1FEFFFFh
	BA512	64 Kwords	1FD0000h-1FDFFFFh
	BA511	64 Kwords	1FC0000h-1FCFFFFh
	BA510	64 kwords	1FB0000h-1FBFFFFh
	BA509	64 kwords	1FA0000h-1FAFFFFh
	BA508	64 kwords	1F90000h-1F9FFFFh
	BA507	64 kwords	1F80000h-1F8FFFFh
	BA506	64 kwords	1F70000h-1F7FFFFh
	BA505	64 kwords	1F60000h-1F6FFFFh
	BA504	64 kwords	1F50000h-1F5FFFFh
	BA503	64 kwords	1F40000h-1F4FFFFh
	BA502	64 kwords	1F30000h-1F3FFFFh
	BA501	64 kwords	1F20000h-1F2FFFFh
	BA500	64 kwords	1F10000h-1F1FFFFh
	BA499	64 kwords	1F00000h-1F0FFFFh
	BA498	64 kwords	1EF0000h-1EFFFFFFh
	BA497	64 kwords	1EE0000h-1EEFFFFh
	BA496	64 kwords	1ED0000h-1EDFFFFh
	BA495	64 kwords	1EC0000h-1ECFFFFh
	BA494	64 kwords	1EB0000h-1EBFFFFh
	BA493	64 kwords	1EA0000h-1EAFfffh
	BA492	64 kwords	1E90000h-1E9FFFFh
	BA491	64 kwords	1E80000h-1E8FFFFh
	BA490	64 kwords	1E70000h-1E7FFFFh
	BA489	64 kwords	1E60000h-1E6FFFFh
	BA488	64 kwords	1E50000h-1E5FFFFh
	BA487	64 kwords	1E40000h-1E4FFFFh
	BA486	64 kwords	1E30000h-1E3FFFFh
	BA485	64 kwords	1E20000h-1E2FFFFh
BA484	64 kwords	1E10000h-1E1FFFFh	
BA483	64 kwords	1E00000h-1E0FFFFh	
Bank 14	BA482	64 kwords	1DF0000h-1DFFFFFFh
	BA481	64 kwords	1DE0000h-1DEFFFFh
	BA480	64 kwords	1DD0000h-1DDFFFFh
	BA479	64 kwords	1DC0000h-1DCFFFFh
	BA478	64 kwords	1DB0000h-1DBFFFFh
	BA477	64 kwords	1DA0000h-1DAFFFFh
	BA476	64 kwords	1D90000h-1D9FFFFh
	BA475	64 kwords	1D80000h-1D8FFFFh
	BA474	64 kwords	1D70000h-1D7FFFFh
	BA473	64 kwords	1D60000h-1D6FFFFh
	BA472	64 kwords	1D50000h-1D5FFFFh
	BA471	64 kwords	1D40000h-1D4FFFFh
BA470	64 kwords	1D30000h-1D3FFFFh	

Bank	Block	Block Size	(x16) Address Range
Bank 14	BA469	64 kwords	1D20000h-1D2FFFFh
	BA468	64 kwords	1D10000h-1D1FFFFh
	BA467	64 kwords	1D00000h-1D0FFFFh
	BA466	64 kwords	1CF0000h-1CFFFFFFh
	BA465	64 kwords	1CE0000h-1CEFFFFh
	BA464	64 kwords	1CD0000h-1CDFFFFh
	BA463	64 kwords	1CC0000h-1CCFFFFh
	BA462	64 kwords	1CB0000h-1CBFFFFh
	BA461	64 kwords	1CA0000h-1CAFFFFh
	BA460	64 kwords	1C90000h-1C9FFFFh
	BA459	64 kwords	1C80000h-1C8FFFFh
	BA458	64 kwords	1C70000h-1C7FFFFh
	BA457	64 kwords	1C60000h-1C6FFFFh
	BA456	64 kwords	1C50000h-1C5FFFFh
	BA455	64 kwords	1C40000h-1C4FFFFh
	BA454	64 kwords	1C30000h-1C3FFFFh
	Bank 13	BA453	64 kwords
BA452		64 kwords	1C10000h-1C1FFFFh
BA451		64 kwords	1C00000h-1C0FFFFh
BA450		64 kwords	1BF0000h-1BFFFFFFh
BA449		64 kwords	1BE0000h-1BEFFFFh
BA448		64 kwords	1BD0000h-1BDFFFFh
BA447		64 kwords	1BC0000h-1BCFFFFh
BA446		64 kwords	1BB0000h-1BBFFFFh
BA445		64 kwords	1BA0000h-1BAFFFFh
BA444		64 kwords	1B90000h-1B9FFFFh
BA443		64 kwords	1B80000h-1B8FFFFh
BA442		64 kwords	1B70000h-1B7FFFFh
BA441		64 kwords	1B60000h-1B6FFFFh
BA440		64 kwords	1B50000h-1B5FFFFh
BA439		64 kwords	1B40000h-1B4FFFFh
BA438		64 kwords	1B30000h-1B3FFFFh
BA437		64 kwords	1B20000h-1B2FFFFh
BA436		64 kwords	1B10000h-1B1FFFFh
BA435		64 kwords	1B00000h-1B0FFFFh
BA434		64 kwords	1AF0000h-1AFFFFFFh
BA433	64 kwords	1AE0000h-1AEFFFFh	
BA432	64 kwords	1AD0000h-1ADFFFFh	
BA431	64 kwords	1AC0000h-1ACFFFFh	
BA430	64 kwords	1AB0000h-1ABFFFFh	
BA429	64 kwords	1AA0000h-1AAFFFFh	
BA428	64 kwords	1A90000h-1A9FFFFh	
BA427	64 kwords	1A80000h-1A8FFFFh	
BA426	64 kwords	1A70000h-1A7FFFFh	
BA425	64 kwords	1A60000h-1A6FFFFh	

Bank	Block	Block Size	(x16) Address Range
Bank 13	BA424	64 kwords	1A50000h-1A5FFFFh
	BA423	64 kwords	1A40000h-1A4FFFFh
	BA422	64 kwords	1A30000h-1A3FFFFh
	BA421	64 kwords	1A20000h-1A2FFFFh
	BA420	64 kwords	1A10000h-1A1FFFFh
	BA419	64 kwords	1A00000h-1A0FFFFh
Bank 12	BA418	64 kwords	19F0000h-19FFFFh
	BA417	64 kwords	19E0000h-19EFFFFh
	BA416	64 kwords	19D0000h-19DFFFFh
	BA415	64 kwords	19C0000h-19CFFFFh
	BA414	64 kwords	19B0000h-19BFFFFh
	BA413	64 kwords	19A0000h-19AFFFFh
	BA412	64 kwords	1990000h-199FFFFh
	BA411	64 kwords	1980000h-198FFFFh
	BA410	64 kwords	1970000h-197FFFFh
	BA409	64 kwords	1960000h-196FFFFh
	BA408	64 kwords	1950000h-195FFFFh
	BA407	64 kwords	1940000h-194FFFFh
	BA406	64 kwords	1930000h-193FFFFh
	BA405	64 kwords	1920000h-192FFFFh
	BA404	64 kwords	1910000h-191FFFFh
	BA403	64 kwords	1900000h-190FFFFh
	BA402	64 kwords	18F0000h-18FFFFh
	BA401	64 kwords	18E0000h-18EFFFFh
	BA400	64 kwords	18D0000h-18DFFFFh
	BA399	64 kwords	18C0000h-18CFFFFh
	BA398	64 kwords	18B0000h-18BFFFFh
	BA397	64 kwords	18A0000h-18AFFFFh
	BA396	64 kwords	1890000h-189FFFFh
	BA395	64 kwords	1880000h-188FFFFh
	BA394	64 kwords	1870000h-187FFFFh
	BA393	64 kwords	1860000h-186FFFFh
	BA392	64 kwords	1850000h-185FFFFh
	BA391	64 kwords	1840000h-184FFFFh
	BA390	64 kwords	1830000h-183FFFFh
	BA389	64 kwords	1820000h-182FFFFh
BA388	64 kwords	1810000h-181FFFFh	
BA387	64 kwords	1800000h-180FFFFh	
Bank 11	BA386	64 kwords	17F0000h-17FFFFh
	BA385	64 kwords	17E0000h-17EFFFFh
	BA384	64 kwords	17D0000h-17DFFFFh
	BA383	64 kwords	17C0000h-17CFFFFh
	BA382	64 kwords	17B0000h-17BFFFFh
	BA381	64 kwords	17A0000h-17AFFFFh
	BA380	64 kwords	1790000h-179FFFFh

Bank	Block	Block Size	(x16) Address Range
Bank 11	BA379	64 kwords	1780000h-178FFFFh
	BA378	64 kwords	1770000h-177FFFFh
	BA377	64 kwords	1760000h-176FFFFh
	BA376	64 kwords	1750000h-175FFFFh
	BA375	64 kwords	1740000h-174FFFFh
	BA374	64 kwords	1730000h-173FFFFh
	BA373	64 kwords	1720000h-172FFFFh
	BA372	64 kwords	1710000h-171FFFFh
	BA371	64 kwords	1700000h-170FFFFh
	BA370	64 kwords	16F0000h-16FFFFFh
	BA369	64 kwords	16E0000h-16EFFFFh
	BA368	64 kwords	16D0000h-16DFFFFh
	BA367	64 kwords	16C0000h-16CFFFFh
	BA366	64 kwords	16B0000h-16BFFFFh
	BA365	64 kwords	16A0000h-16AFFFFh
	BA364	64 kwords	1690000h-169FFFFh
	BA363	64 kwords	1680000h-168FFFFh
	BA362	64 kwords	1670000h-167FFFFh
	BA361	64 kwords	1660000h-166FFFFh
	BA360	64 kwords	1650000h-165FFFFh
Bank 10	BA359	64 kwords	1640000h-164FFFFh
	BA358	64 kwords	1630000h-163FFFFh
	BA357	64 kwords	1620000h-162FFFFh
	BA356	64 kwords	1610000h-161FFFFh
	BA355	64 kwords	1600000h-160FFFFh
	BA354	64 kwords	15F0000h-15FFFFFh
	BA353	64 kwords	15E0000h-15EFFFFh
	BA352	64 kwords	15D0000h-15DFFFFh
	BA351	64 kwords	15C0000h-15CFFFFh
	BA350	64 kwords	15B0000h-15BFFFFh
	BA349	64 kwords	15A0000h-15AFFFFh
	BA348	64 kwords	1590000h-159FFFFh
	BA347	64 kwords	1580000h-158FFFFh
	BA346	64 kwords	1570000h-157FFFFh
	BA345	64 kwords	1560000h-156FFFFh
	BA344	64 kwords	1550000h-155FFFFh
	BA343	64 kwords	1540000h-154FFFFh
	BA342	64 kwords	1530000h-153FFFFh
	BA341	64 kwords	1520000h-152FFFFh
	BA340	64 kwords	1510000h-151FFFFh
BA339	64 kwords	1500000h-150FFFFh	
BA338	64 kwords	14F0000h-14FFFFFh	
BA337	64 kwords	14E0000h-14EFFFFh	
BA336	64 kwords	14D0000h-14DFFFFh	

Bank	Block	Block Size	(x16) Address Range
Bank 10	BA335	64 kwords	14C0000h-14CFFFFh
	BA334	64 kwords	14B0000h-14BFFFFh
	BA333	64 kwords	14A0000h-14AFFFFh
	BA332	64 kwords	1490000h-149FFFFh
	BA331	64 kwords	1480000h-148FFFFh
	BA330	64 kwords	1470000h-147FFFFh
	BA329	64 kwords	1460000h-146FFFFh
	BA328	64 kwords	1450000h-145FFFFh
	BA327	64 kwords	1440000h-144FFFFh
	BA326	64 kwords	1430000h-143FFFFh
	BA325	64 kwords	1420000h-142FFFFh
	BA324	64 kwords	1410000h-141FFFFh
Bank 9	BA323	64 kwords	1400000h-140FFFFh
	BA322	64 kwords	13F0000h-13FFFFh
	BA321	64 kwords	13E0000h-13EFFFFh
	BA320	64 kwords	13D0000h-13DFFFFh
	BA319	64 kwords	13C0000h-13CFFFFh
	BA318	64 kwords	13B0000h-13BFFFFh
	BA317	64 kwords	13A0000h-13AFFFFh
	BA316	64 kwords	1390000h-139FFFFh
	BA315	64 kwords	1380000h-138FFFFh
	BA314	64 kwords	1370000h-137FFFFh
	BA313	64 kwords	1360000h-136FFFFh
	BA312	64 kwords	1350000h-135FFFFh
	BA311	64 kwords	1340000h-134FFFFh
	BA310	64 kwords	1330000h-133FFFFh
	BA309	64 kwords	1320000h-132FFFFh
	BA308	64 kwords	1310000h-131FFFFh
	BA307	64 kwords	1300000h-130FFFFh
	BA306	64 kwords	12F0000h-12FFFFh
	BA305	64 kwords	12E0000h-12EFFFFh
	BA304	64 kwords	12D0000h-12DFFFFh
	BA303	64 kwords	12C0000h-12CFFFFh
	BA302	64 kwords	12B0000h-12BFFFFh
	BA301	64 kwords	12A0000h-12AFFFFh
	BA300	64 kwords	1290000h-129FFFFh
	BA299	64 kwords	1280000h-128FFFFh
	BA298	64 kwords	1270000h-127FFFFh
	BA297	64 kwords	1260000h-126FFFFh
	BA296	64 kwords	1250000h-125FFFFh
BA295	64 kwords	1240000h-124FFFFh	
BA294	64 kwords	1230000h-123FFFFh	
BA293	64 kwords	1220000h-122FFFFh	
BA292	64 kwords	1210000h-121FFFFh	
BA291	64 kwords	1200000h-120FFFFh	

Bank	Block	Block Size	(x16) Address Range
Bank 8	BA290	64 kwords	11F0000h-11FFFFFFh
	BA289	64 kwords	11E0000h-11EFFFFFFh
	BA288	64 kwords	11D0000h-11DFFFFFFh
	BA287	64 kwords	11C0000h-11CFFFFFFh
	BA286	64 kwords	11B0000h-11BFFFFFFh
	BA285	64 kwords	11A0000h-11AFFFFFFh
	BA284	64 kwords	1190000h-119FFFFFFh
	BA283	64 kwords	1180000h-118FFFFFFh
	BA282	64 kwords	1170000h-117FFFFFFh
	BA281	64 kwords	1160000h-116FFFFFFh
	BA280	64 kwords	1150000h-115FFFFFFh
	BA279	64 kwords	1140000h-114FFFFFFh
	BA278	64 kwords	1130000h-113FFFFFFh
	BA277	64 kwords	1120000h-112FFFFFFh
	BA276	64 kwords	1110000h-111FFFFFFh
	BA275	64 kwords	1100000h-110FFFFFFh
	BA274	64 kwords	10F0000h-10FFFFFFh
	BA273	64 kwords	10E0000h-10EFFFFFFh
	BA272	64 kwords	10D0000h-10DFFFFFFh
	BA271	64 kwords	10C0000h-10CFFFFFFh
	BA270	64 kwords	10B0000h-10BFFFFFFh
	BA269	64 kwords	10A0000h-10AFFFFFFh
	BA268	64 kwords	1090000h-109FFFFFFh
	BA267	64 kwords	1080000h-108FFFFFFh
	BA266	64 kwords	1070000h-107FFFFFFh
	BA265	64 kwords	1060000h-106FFFFFFh
	BA264	64 kwords	1050000h-105FFFFFFh
	BA263	64 kwords	1040000h-104FFFFFFh
BA262	64 kwords	1030000h-103FFFFFFh	
BA261	64 kwords	1020000h-102FFFFFFh	
BA260	64 kwords	1010000h-101FFFFFFh	
BA259	64 kwords	1000000h-100FFFFFFh	
Bank 7	BA258	64 kwords	0FF0000h-0FFFFFFFh
	BA257	64 kwords	0FE0000h-0FEFFFFFFh
	BA256	64 kwords	0FD0000h-0FDFFFFFFh
	BA255	64 kwords	0FC0000h-0FCFFFFFFh
	BA254	64 kwords	0FB0000h-0FBFFFFFFh
	BA253	64 kwords	0FA0000h-0FAFFFFFFh
	BA252	64 kwords	0F90000h-0F9FFFFFFh
	BA251	64 kwords	0F80000h-0F8FFFFFFh
	BA250	64 kwords	0F70000h-0F7FFFFFFh
	BA249	64 kwords	0F60000h-0F6FFFFFFh
	BA248	64 kwords	0F50000h-0F5FFFFFFh
	BA247	64 kwords	0F40000h-0F4FFFFFFh
BA246	64 kwords	0F30000h-0F3FFFFFFh	

Bank	Block	Block Size	(x16) Address Range
Bank 7	BA245	64 kwords	0F20000h-0F2FFFFh
	BA244	64 kwords	0F10000h-0F1FFFFh
	BA243	64 kwords	0F00000h-0F0FFFFh
	BA242	64 kwords	0EF0000h-0EFFFFFFh
	BA241	64 kwords	0EE0000h-0EFFFFFFh
	BA240	64 kwords	0ED0000h-0EDFFFFh
	BA239	64 kwords	0EC0000h-0ECFFFFh
	BA238	64 kwords	0EB0000h-0EBFFFFh
	BA237	64 kwords	0EA0000h-0EAFFFFh
	BA236	64 kwords	0E90000h-0E9FFFFh
	BA235	64 kwords	0E80000h-0E8FFFFh
	BA234	64 kwords	0E70000h-0E7FFFFh
	BA233	64 kwords	0E60000h-0E6FFFFh
	BA232	64 kwords	0E50000h-0E5FFFFh
	BA231	64 kwords	0E40000h-0E4FFFFh
	BA230	64 kwords	0E30000h-0E3FFFFh
	Bank 6	BA229	64 kwords
BA228		64 kwords	0E10000h-0E1FFFFh
BA227		64 kwords	0E00000h-0E0FFFFh
BA226		64 kwords	0DF0000h-0DFFFFFFh
BA225		64 kwords	0DE0000h-0DEFFFFh
BA224		64 kwords	0DD0000h-0DDFFFFh
BA223		64 kwords	0DC0000h-0DCFFFFh
BA222		64 kwords	0DB0000h-0DBFFFFh
BA221		64 kwords	0DA0000h-0DAFFFFh
BA220		64 kwords	0D90000h-0D9FFFFh
BA219		64 kwords	0D80000h-0D8FFFFh
BA218		64 kwords	0D70000h-0D7FFFFh
BA217		64 kwords	0D60000h-0D6FFFFh
BA216		64 kwords	0D50000h-0D5FFFFh
BA215		64 kwords	0D40000h-0D4FFFFh
BA214		64 kwords	0D30000h-0D3FFFFh
BA213		64 kwords	0D20000h-0D2FFFFh
BA212		64 kwords	0D10000h-0D1FFFFh
BA211		64 kwords	0D00000h-0D0FFFFh
BA210		64 kwords	0CF0000h-0CFFFFFFh
BA209		64 kwords	0CE0000h-0CEFFFFh
BA208	64 kwords	0CD0000h-0CDFFFFh	
BA207	64 kwords	0CC0000h-0CCFFFFh	
BA206	64 kwords	0CB0000h-0CBFFFFh	
BA205	64 kwords	0CA0000h-0CAFFFFh	
BA204	64 kwords	0C90000h-0C9FFFFh	
BA203	64 kwords	0C80000h-0C8FFFFh	
BA202	64 kwords	0C70000h-0C7FFFFh	
BA201	64 kwords	0C60000h-0C6FFFFh	

Bank	Block	Block Size	(x16) Address Range
Bank 6	BA200	64 kwords	0C50000h-0C5FFFFh
	BA199	64 kwords	0C40000h-0C4FFFFh
	BA198	64 kwords	0C30000h-0C3FFFFh
	BA197	64 kwords	0C20000h-0C2FFFFh
	BA196	64 kwords	0C10000h-0C1FFFFh
	BA195	64 kwords	0C00000h-0C0FFFFh
Bank 5	BA194	64 kwords	0BF0000h-0BFFFFFFh
	BA193	64 kwords	0BE0000h-0BEFFFFh
	BA192	64 kwords	0BD0000h-0BDFFFFh
	BA191	64 kwords	0BC0000h-0BCFFFFh
	BA190	64 kwords	0BB0000h-0BBFFFFh
	BA189	64 kwords	0BA0000h-0BAFFFFh
	BA188	64 kwords	0B90000h-0B9FFFFh
	BA187	64 kwords	0B80000h-0B8FFFFh
	BA186	64 kwords	0B70000h-0B7FFFFh
	BA185	64 kwords	0B60000h-0B6FFFFh
	BA184	64 kwords	0B50000h-0B5FFFFh
	BA183	64 kwords	0B40000h-0B4FFFFh
	BA182	64 kwords	0B30000h-0B3FFFFh
	BA181	64 kwords	0B20000h-0B2FFFFh
	BA180	64 kwords	0B10000h-0B1FFFFh
	BA179	64 kwords	0B00000h-0B0FFFFh
	BA178	64 kwords	0AF0000h-0AFFFFFh
	BA177	64 kwords	0AE0000h-0AEFFFFh
	BA176	64 kwords	0AD0000h-0ADFFFFh
	BA175	64 kwords	0AC0000h-0ACFFFFh
	BA174	64 kwords	0AB0000h-0ABFFFFh
	BA173	64 kwords	0AA0000h-0AAFFFFh
	BA172	64 kwords	0A90000h-0A9FFFFh
	BA171	64 kwords	0A80000h-0A8FFFFh
	BA170	64 kwords	0A70000h-0A7FFFFh
	BA169	64 kwords	0A60000h-0A6FFFFh
	BA168	64 kwords	0A50000h-0A5FFFFh
	BA167	64 kwords	0A40000h-0A4FFFFh
BA166	64 kwords	0A30000h-0A3FFFFh	
BA165	64 kwords	0A20000h-0A2FFFFh	
BA164	64 kwords	0A10000h-0A1FFFFh	
BA163	64 kwords	0A00000h-0A0FFFFh	
Bank 4	BA162	64 kwords	09F0000h-09FFFFFFh
	BA161	64 kwords	09E0000h-09EFFFFh
	BA160	64 kwords	09D0000h-09DFFFFh
	BA159	64 kwords	09C0000h-09CFFFFh
	BA158	64 kwords	09B0000h-09BFFFFh
	BA157	64 kwords	09A0000h-09AFFFFh
BA156	64 kwords	0990000h-099FFFFh	

Bank	Block	Block Size	(x16) Address Range
Bank 4	BA155	64 kwords	0980000h-098FFFFh
	BA154	64 kwords	0970000h-097FFFFh
	BA153	64 kwords	0960000h-096FFFFh
	BA152	64 kwords	0950000h-095FFFFh
	BA151	64 kwords	0940000h-094FFFFh
	BA150	64 kwords	0930000h-093FFFFh
	BA149	64 kwords	0920000h-092FFFFh
	BA148	64 kwords	0910000h-091FFFFh
	BA147	64 kwords	0900000h-090FFFFh
	BA146	64 kwords	08F0000h-08FFFFFh
	BA145	64 kwords	08E0000h-08EFFFFh
	BA144	64 kwords	08D0000h-08DFFFFh
	BA143	64 kwords	08C0000h-08CFFFFh
	BA142	64 kwords	08B0000h-08BFFFFh
	BA141	64 kwords	08A0000h-08AFFFFh
	BA140	64 kwords	0890000h-089FFFFh
	BA139	64 kwords	0880000h-088FFFFh
	BA138	64 kwords	0870000h-087FFFFh
	BA137	64 kwords	0860000h-086FFFFh
	Bank 3	BA136	64 kwords
BA135		64 kwords	0840000h-084FFFFh
BA134		64 kwords	0830000h-083FFFFh
BA133		64 kwords	0820000h-082FFFFh
BA132		64 kwords	0810000h-081FFFFh
BA131		64 kwords	0800000h-080FFFFh
BA130		64 kwords	07F0000h-07FFFFFh
BA129		64 kwords	07E0000h-07EFFFFh
BA128		64 kwords	07D0000h-07DFFFFh
BA127		64 kwords	07C0000h-07CFFFFh
BA126		64 kwords	07B0000h-07BFFFFh
BA125		64 kwords	07A0000h-07AFFFFh
BA124		64 kwords	0790000h-079FFFFh
BA123		64 kwords	0780000h-078FFFFh
BA122		64 kwords	0770000h-077FFFFh
BA121		64 kwords	0760000h-076FFFFh
BA120		64 kwords	0750000h-075FFFFh
BA119		64 kwords	0740000h-074FFFFh
BA118		64 kwords	0730000h-073FFFFh
BA117		64 kwords	0720000h-072FFFFh
BA116	64 kwords	0710000h-071FFFFh	
BA115	64 kwords	0700000h-070FFFFh	
BA114	64 kwords	06F0000h-06FFFFFh	
BA113	64 kwords	06E0000h-06EFFFFh	
BA112	64 kwords	06D0000h-06DFFFFh	
BA111	64 kwords	06C0000h-06CFFFFh	

Bank	Block	Block Size	(x16) Address Range
Bank 3	BA110	64 kwords	06B0000h-06BFFFFh
	BA109	64 kwords	06A0000h-06AFFFFh
	BA108	64 kwords	0690000h-069FFFFh
	BA107	64 kwords	0680000h-068FFFFh
	BA106	64 kwords	0670000h-067FFFFh
	BA105	64 kwords	0660000h-066FFFFh
	BA104	64 kwords	0650000h-065FFFFh
	BA103	64 kwords	0640000h-064FFFFh
	BA102	64 kwords	0630000h-063FFFFh
	BA101	64 kwords	0620000h-062FFFFh
	BA100	64 kwords	0610000h-061FFFFh
Bank 2	BA99	64 kwords	0600000h-060FFFFh
	BA98	64 kwords	05F0000h-05FFFFFh
	BA97	64 kwords	05E0000h-05EFFFFh
	BA96	64 kwords	05D0000h-05DFFFFh
	BA95	64 kwords	05C0000h-05CFFFFh
	BA94	64 kwords	05B0000h-05BFFFFh
	BA93	64 kwords	05A0000h-05AFFFFh
	BA92	64 kwords	0590000h-059FFFFh
	BA91	64 kwords	0580000h-058FFFFh
	BA90	64 kwords	0570000h-057FFFFh
	BA89	64 kwords	0560000h-056FFFFh
	BA88	64 kwords	0550000h-055FFFFh
	BA87	64 kwords	0540000h-054FFFFh
	BA86	64 kwords	0530000h-053FFFFh
	BA85	64 kwords	0520000h-052FFFFh
	BA84	64 kwords	0510000h-051FFFFh
	BA83	64 kwords	0500000h-050FFFFh
	BA82	64 kwords	04F0000h-04FFFFFh
	BA81	64 kwords	04E0000h-04EFFFFh
	BA80	64 kwords	04D0000h-04DFFFFh
	BA79	64 kwords	04C0000h-04CFFFFh
	BA78	64 kwords	04B0000h-04BFFFFh
	BA77	64 kwords	04A0000h-04AFFFFh
	BA76	64 kwords	0490000h-049FFFFh
	BA75	64 kwords	0480000h-048FFFFh
	BA74	64 kwords	0470000h-047FFFFh
	BA73	64 kwords	0460000h-046FFFFh
	BA72	64 kwords	0450000h-045FFFFh
BA71	64 kwords	0440000h-044FFFFh	
BA70	64 kwords	0430000h-043FFFFh	
BA69	64 kwords	0420000h-042FFFFh	
BA68	64 kwords	0410000h-041FFFFh	
BA67	64 kwords	0400000h-040FFFFh	
Bank 1	BA66	64 kwords	03F0000h-03FFFFFh

Bank	Block	Block Size	(x16) Address Range
Bank 1	BA65	64 kwords	03E0000h-03EFFFFh
	BA64	64 kwords	03D0000h-03DFFFFh
	BA63	64 kwords	03C0000h-03CFFFFh
	BA62	64 kwords	03B0000h-03BFFFFh
	BA61	64 kwords	03A0000h-03AFFFFh
	BA60	64 kwords	0390000h-039FFFFh
	BA59	64 kwords	0380000h-038FFFFh
	BA58	64 kwords	0370000h-037FFFFh
	BA57	64 kwords	0360000h-036FFFFh
	BA56	64 kwords	0350000h-035FFFFh
	BA55	64 kwords	0340000h-034FFFFh
	BA54	64 kwords	0330000h-033FFFFh
	BA53	64 kwords	0320000h-032FFFFh
	BA52	64 kwords	0310000h-031FFFFh
	BA51	64 kwords	0300000h-030FFFFh
	BA50	64 kwords	02F0000h-02FFFFh
	BA49	64 kwords	02E0000h-02EFFFFh
	BA48	64 kwords	02D0000h-02DFFFFh
	BA47	64 kwords	02C0000h-02CFFFFh
	BA46	64 kwords	02B0000h-02BFFFFh
	BA45	64 kwords	02A0000h-02AFFFFh
	BA44	64 kwords	0290000h-029FFFFh
	BA43	64 kwords	0280000h-028FFFFh
	BA42	64 kwords	0270000h-027FFFFh
	BA41	64 kwords	0260000h-026FFFFh
	BA40	64 kwords	0250000h-025FFFFh
	BA39	64 kwords	0240000h-024FFFFh
	BA38	64 kwords	0230000h-023FFFFh
BA37	64 kwords	0220000h-022FFFFh	
BA36	64 kwords	0210000h-021FFFFh	
BA35	64 kwords	0200000h-020FFFFh	
Bank 0	BA34	64 kwords	01F0000h-01FFFFh
	BA33	64 kwords	01E0000h-01EFFFFh
	BA32	64 kwords	01D0000h-01DFFFFh
	BA31	64 kwords	01C0000h-01CFFFFh
	BA30	64 kwords	01B0000h-01BFFFFh
	BA29	64 kwords	01A0000h-01AFFFFh
	BA28	64 kwords	0190000h-019FFFFh
	BA27	64 kwords	0180000h-018FFFFh
	BA26	64 kwords	0170000h-017FFFFh
	BA25	64 kwords	0160000h-016FFFFh
	BA24	64 kwords	0150000h-015FFFFh
	BA23	64 kwords	0140000h-014FFFFh
BA22	64 kwords	0130000h-013FFFFh	
BA21	64 kwords	0120000h-012FFFFh	

Bank	Block	Block Size	(x16) Address Range
Bank 0	BA20	64 kwords	0110000h-011FFFFh
	BA19	64 kwords	0100000h-010FFFFh
	BA18	64 kwords	00F0000h-00FFFFFFh
	BA17	64 kwords	00E0000h-00EFFFFh
	BA16	64 kwords	00D0000h-00DFFFFh
	BA15	64 kwords	00C0000h-00CFFFFh
	BA14	64 kwords	00B0000h-00BFFFFh
	BA13	64 kwords	00A0000h-00AFFFFh
	BA12	64 kwords	0090000h-009FFFFh
	BA11	64 kwords	0080000h-008FFFFh
	BA10	64 kwords	0070000h-007FFFFh
	BA9	64 kwords	0060000h-006FFFFh
	BA8	64 kwords	0050000h-005FFFFh
	BA7	64 kwords	0040000h-004FFFFh
	BA6	64 kwords	0030000h-003FFFFh
	BA5	64 kwords	0020000h-002FFFFh
	BA4	64 kwords	0010000h-001FFFFh
	BA3	16 kwords	000C000h-000FFFFh
	BA2	16 kwords	0008000h-000BFFFFh
	BA1	16 kwords	0004000h-0007FFFFh
BA0	16 kwords	0000000h-0003FFFFh	

[Table 20] Bottom Boot OTP Block Addresses

OTP	Block Address A24 ~ A8	Block Size	(x16) Address Range*
	00000h	512 words	0000000h-00001FFh

After entering OTP Block, any issued addresses should be in the range of OTP block address.

[Table 21] Uniform Block Address Table

Bank	Block	Block Size	(x16) Address Range
Bank 0	BA511	64 kwords	1FF0000h-1FFFFFFh
	BA510	64 kwords	1FE0000h-1FEFFFFh
	BA509	64 kwords	1FD0000h-1FDFFFFh
	BA508	64 kwords	1FC0000h-1FCFFFFh
	BA507	64 kwords	1FB0000h-1FBFFFFh
	BA506	64 kwords	1FA0000h-1FAFFFFh
	BA505	64 kwords	1F90000h-1F9FFFFh
	BA504	64 kwords	1F80000h-1F8FFFFh
	BA503	64 kwords	1F70000h-1F7FFFFh
	BA502	64 kwords	1F60000h-1F6FFFFh
	BA501	64 kwords	1F50000h-1F5FFFFh
	BA500	64 kwords	1F40000h-1F4FFFFh
	BA499	64 kwords	1F30000h-1F3FFFFh
	BA498	64 kwords	1F20000h-1F2FFFFh
	BA497	64 kwords	1F10000h-1F1FFFFh
	BA496	64 kwords	1F00000h-1F0FFFFh
	BA495	64 kwords	1EF0000h-1EFFFFFFh
	BA494	64 kwords	1EE0000h-1EEFFFFh
	BA493	64 kwords	1ED0000h-1EDFFFFh
	BA492	64 kwords	1EC0000h-1ECFFFFh
	BA491	64 kwords	1EB0000h-1EBFFFFh
	BA490	64 kwords	1EA0000h-1EAFffffh
	BA489	64 kwords	1E90000h-1E9FFFFh
	BA488	64 kwords	1E80000h-1E8FFFFh
	BA487	64 kwords	1E70000h-1E7FFFFh
	BA486	64 kwords	1E60000h-1E6FFFFh
	BA485	64 kwords	1E50000h-1E5FFFFh
	BA484	64 kwords	1E40000h-1E4FFFFh
	BA483	64 kwords	1E30000h-1E3FFFFh
	BA482	64 kwords	1E20000h-1E2FFFFh
BA481	64 kwords	1E10000h-1E1FFFFh	
BA480	64 kwords	1E00000h-1E0FFFFh	
Bank 1	BA479	64 kwords	1DF0000h-1DFFFFFFh
	BA478	64 kwords	1DE0000h-1DEFFFFh
	BA477	64 kwords	1DD0000h-1DDFFFFh
	BA476	64 kwords	1DC0000h-1DCFFFFh
	BA475	64 kwords	1DB0000h-1DBFFFFh
	BA474	64 kwords	1DA0000h-1DAFFFFh
	BA473	64 kwords	1D90000h-1D9FFFFh
	BA472	64 kwords	1D80000h-1D8FFFFh
	BA471	64 kwords	1D70000h-1D7FFFFh
BA470	64 kwords	1D60000h-1D6FFFFh	

Bank	Block	Block Size	(x16) Address Range
Bank 1	BA469	64 kwords	1D50000h-1D5FFFFh
	BA468	64 kwords	1D40000h-1D4FFFFh
	BA467	64 kwords	1D30000h-1D3FFFFh
	BA466	64 kwords	1D20000h-1D2FFFFh
	BA465	64 kwords	1D10000h-1D1FFFFh
	BA464	64 kwords	1D00000h-1D0FFFFh
	BA463	64 kwords	1CF0000h-1CFFFFFFh
	BA462	64 kwords	1CE0000h-1CEFFFFh
	BA461	64 kwords	1CD0000h-1CDFFFFh
	BA460	64 kwords	1CC0000h-1CCFFFFh
	BA459	64 kwords	1CB0000h-1CBFFFFh
	BA458	64 kwords	1CA0000h-1CAFFFFh
	BA457	64 kwords	1C90000h-1C9FFFFh
	BA456	64 kwords	1C80000h-1C8FFFFh
	BA455	64 kwords	1C70000h-1C7FFFFh
	BA454	64 kwords	1C60000h-1C6FFFFh
	BA453	64 kwords	1C50000h-1C5FFFFh
	BA452	64 kwords	1C40000h-1C4FFFFh
	BA451	64 kwords	1C30000h-1C3FFFFh
	BA450	64 kwords	1C20000h-1C2FFFFh
BA449	64 kwords	1C10000h-1C1FFFFh	
BA448	64 kwords	1C00000h-1C0FFFFh	
Bank 2	BA447	64 kwords	1BF0000h-1BFFFFFFh
	BA446	64 kwords	1BE0000h-1BEFFFFh
	BA445	64 kwords	1BD0000h-1BDFFFFh
	BA444	64 kwords	1BC0000h-1BCFFFFh
	BA443	64 kwords	1BB0000h-1BBFFFFh
	BA442	64 kwords	1BA0000h-1BAFFFFh
	BA441	64 kwords	1B90000h-1B9FFFFh
	BA440	64 kwords	1B80000h-1B8FFFFh
	BA439	64 kwords	1B70000h-1B7FFFFh
	BA438	64 kwords	1B60000h-1B6FFFFh
	BA437	64 kwords	1B50000h-1B5FFFFh
	BA436	64 kwords	1B40000h-1B4FFFFh
	BA435	64 kwords	1B30000h-1B3FFFFh
	BA434	64 kwords	1B20000h-1B2FFFFh
	BA433	64 kwords	1B10000h-1B1FFFFh
	BA432	64 kwords	1B00000h-1B0FFFFh
	BA431	64 kwords	1AF0000h-1AFFFFFFh
	BA430	64 kwords	1AE0000h-1AEFFFFh
	BA429	64 kwords	1AD0000h-1ADFFFFh
	BA428	64 kwords	1AC0000h-1ACFFFFh
BA427	64 kwords	1AB0000h-1ABFFFFh	
BA426	64 kwords	1AA0000h-1AAFFFFh	
BA425	64 kwords	1A90000h-1A9FFFFh	

Bank	Block	Block Size	(x16) Address Range
Bank 2	BA424	64 kwords	1A80000h-1A8FFFFh
	BA423	64 kwords	1A70000h-1A7FFFFh
	BA422	64 kwords	1A60000h-1A6FFFFh
	BA421	64 kwords	1A50000h-1A5FFFFh
	BA420	64 kwords	1A40000h-1A4FFFFh
	BA419	64 kwords	1A30000h-1A3FFFFh
	BA418	64 kwords	1A20000h-1A2FFFFh
	BA417	64 kwords	1A10000h-1A1FFFFh
Bank 3	BA416	64 kwords	1A00000h-1A0FFFFh
	BA415	64 kwords	19F0000h-19FFFFh
	BA414	64 kwords	19E0000h-19EFFFFh
	BA413	64 kwords	19D0000h-19DFFFFh
	BA412	64 kwords	19C0000h-19CFFFFh
	BA411	64 kwords	19B0000h-19BFFFFh
	BA410	64 kwords	19A0000h-19AFFFFh
	BA409	64 kwords	1990000h-199FFFFh
	BA408	64 kwords	1980000h-198FFFFh
	BA407	64 kwords	1970000h-197FFFFh
	BA406	64 kwords	1960000h-196FFFFh
	BA405	64 kwords	1950000h-195FFFFh
	BA404	64 kwords	1940000h-194FFFFh
	BA403	64 kwords	1930000h-193FFFFh
	BA402	64 kwords	1920000h-192FFFFh
	BA401	64 kwords	1910000h-191FFFFh
	BA400	64 kwords	1900000h-190FFFFh
	BA399	64 kwords	18F0000h-18FFFFh
	BA398	64 kwords	18E0000h-18EFFFFh
	BA397	64 kwords	18D0000h-18DFFFFh
	BA396	64 kwords	18C0000h-18CFFFFh
	BA395	64 kwords	18B0000h-18BFFFFh
	BA394	64 kwords	18A0000h-18AFFFFh
	BA393	64 kwords	1890000h-189FFFFh
BA392	64 kwords	1880000h-188FFFFh	
BA391	64 kwords	1870000h-187FFFFh	
BA390	64 kwords	1860000h-186FFFFh	
BA389	64 kwords	1850000h-185FFFFh	
BA388	64 kwords	1840000h-184FFFFh	
BA387	64 kwords	1830000h-183FFFFh	
BA386	64 kwords	1820000h-182FFFFh	
BA385	64 kwords	1810000h-181FFFFh	
BA384	64 kwords	1800000h-180FFFFh	
Bank 4	BA383	64 kwords	17F0000h-17FFFFh
	BA382	64 kwords	17E0000h-17EFFFFh
	BA381	64 kwords	17D0000h-17DFFFFh
	BA380	64 kwords	17C0000h-17CFFFFh

Bank	Block	Block Size	(x16) Address Range
Bank 4	BA379	64 kwords	17B0000h-17BFFFFh
	BA378	64 kwords	17A0000h-17AFFFFh
	BA377	64 kwords	1790000h-179FFFFh
	BA376	64 kwords	1780000h-178FFFFh
	BA375	64 kwords	1770000h-177FFFFh
	BA374	64 kwords	1760000h-176FFFFh
	BA373	64 kwords	1750000h-175FFFFh
	BA372	64 kwords	1740000h-174FFFFh
	BA371	64 kwords	1730000h-173FFFFh
	BA370	64 kwords	1720000h-172FFFFh
	BA369	64 kwords	1710000h-171FFFFh
	BA368	64 kwords	1700000h-170FFFFh
	BA367	64 kwords	16F0000h-16FFFFh
	BA366	64 kwords	16E0000h-16EFFFFh
	BA365	64 kwords	16D0000h-16DFFFFh
	BA364	64 kwords	16C0000h-16CFFFFh
	BA363	64 kwords	16B0000h-16BFFFFh
	BA362	64 kwords	16A0000h-16AFFFFh
	BA361	64 kwords	1690000h-169FFFFh
	BA360	64 kwords	1680000h-168FFFFh
	BA359	64 kwords	1670000h-167FFFFh
	BA358	64 kwords	1660000h-166FFFFh
	BA357	64 kwords	1650000h-165FFFFh
	BA356	64 kwords	1640000h-164FFFFh
BA355	64 kwords	1630000h-163FFFFh	
BA354	64 kwords	1620000h-162FFFFh	
BA353	64 kwords	1610000h-161FFFFh	
BA352	64 kwords	1600000h-160FFFFh	
Bank5	BA351	64 kwords	15F0000h-15FFFFh
	BA350	64 kwords	15E0000h-15EFFFFh
	BA349	64 kwords	15D0000h-15DFFFFh
	BA348	64 kwords	15C0000h-15CFFFFh
	BA347	64 kwords	15B0000h-15BFFFFh
	BA346	64 kwords	15A0000h-15AFFFFh
	BA345	64 kwords	1590000h-159FFFFh
	BA344	64 kwords	1580000h-158FFFFh
	BA343	64 kwords	1570000h-157FFFFh
	BA342	64 kwords	1560000h-156FFFFh
	BA341	64 kwords	1550000h-155FFFFh
	BA340	64 kwords	1540000h-154FFFFh
	BA339	64 kwords	1530000h-153FFFFh
	BA338	64 kwords	1520000h-152FFFFh
BA337	64 kwords	1510000h-151FFFFh	
BA336	64 kwords	1500000h-150FFFFh	

Bank	Block	Block Size	(x16) Address Range
Bank 5	BA335	64 kwords	14F0000h-14FFFFFFh
	BA334	64 kwords	14E0000h-14FFFFFFh
	BA333	64 kwords	14D0000h-14FFFFFFh
	BA332	64 kwords	14C0000h-14FFFFFFh
	BA331	64 kwords	14B0000h-14FFFFFFh
	BA330	64 kwords	14A0000h-14FFFFFFh
	BA329	64 kwords	1490000h-149FFFFFFh
	BA328	64 kwords	1480000h-148FFFFFFh
	BA327	64 kwords	1470000h-147FFFFFFh
	BA326	64 kwords	1460000h-146FFFFFFh
	BA325	64 kwords	1450000h-145FFFFFFh
	BA324	64 kwords	1440000h-144FFFFFFh
	BA323	64 kwords	1430000h-143FFFFFFh
	BA322	64 kwords	1420000h-142FFFFFFh
	BA321	64 kwords	1410000h-141FFFFFFh
BA320	64 kwords	1400000h-140FFFFFFh	
Bank 6	BA319	64 kwords	13F0000h-13FFFFFFh
	BA318	64 kwords	13E0000h-13EFFFFFFh
	BA317	64 kwords	13D0000h-13DFFFFFFh
	BA316	64 kwords	13C0000h-13CFFFFFFh
	BA315	64 kwords	13B0000h-13BFFFFFFh
	BA314	64 kwords	13A0000h-13AFFFFFFh
	BA313	64 kwords	1390000h-139FFFFFFh
	BA312	64 kwords	1380000h-138FFFFFFh
	BA311	64 kwords	1370000h-137FFFFFFh
	BA310	64 kwords	1360000h-136FFFFFFh
	BA309	64 kwords	1350000h-135FFFFFFh
	BA308	64 kwords	1340000h-134FFFFFFh
	BA307	64 kwords	1330000h-133FFFFFFh
	BA306	64 kwords	1320000h-132FFFFFFh
	BA305	64 kwords	1310000h-131FFFFFFh
	BA304	64 kwords	1300000h-130FFFFFFh
	BA303	64 kwords	12F0000h-12FFFFFFh
	BA302	64 kwords	12E0000h-12EFFFFFFh
	BA301	64 kwords	12D0000h-12DFFFFFFh
	BA300	64 kwords	12C0000h-12CFFFFFFh
	BA299	64 kwords	12B0000h-12BFFFFFFh
BA298	64 kwords	12A0000h-12AFFFFFFh	
BA297	64 kwords	1290000h-129FFFFFFh	
BA296	64 kwords	1280000h-128FFFFFFh	
BA295	64 kwords	1270000h-127FFFFFFh	
BA294	64 kwords	1260000h-126FFFFFFh	
BA293	64 kwords	1250000h-125FFFFFFh	
BA292	64 kwords	1240000h-124FFFFFFh	
BA291	64 kwords	1230000h-123FFFFFFh	

Bank	Block	Block Size	(x16) Address Range
Bank 6	BA290	64 kwords	1220000h-122FFFFh
	BA289	64 kwords	1210000h-121FFFFh
	BA288	64 kwords	1200000h-120FFFFh
Bank 7	BA287	64 kwords	11F0000h-11FFFFFFh
	BA286	64 kwords	11E0000h-11EFFFFh
	BA285	64 kwords	11D0000h-11DFFFFh
	BA284	64 kwords	11C0000h-11CFFFFh
	BA283	64 kwords	11B0000h-11BFFFFh
	BA282	64 kwords	11A0000h-11AFFFFh
	BA281	64 kwords	1190000h-119FFFFh
	BA280	64 kwords	1180000h-118FFFFh
	BA279	64 kwords	1170000h-117FFFFh
	BA278	64 kwords	1160000h-116FFFFh
	BA277	64 kwords	1150000h-115FFFFh
	BA276	64 kwords	1140000h-114FFFFh
	BA275	64 kwords	1130000h-113FFFFh
	BA274	64 kwords	1120000h-112FFFFh
	BA273	64 kwords	1110000h-111FFFFh
	BA272	64 kwords	1100000h-110FFFFh
	BA271	64 kwords	10F0000h-10FFFFFFh
	BA270	64 kwords	10E0000h-10EFFFFh
	BA269	64 kwords	10D0000h-10DFFFFh
	BA268	64 kwords	10C0000h-10CFFFFh
	BA267	64 kwords	10B0000h-10BFFFFh
	BA266	64 kwords	10A0000h-10AFFFFh
	BA265	64 kwords	1090000h-109FFFFh
	BA264	64 kwords	1080000h-108FFFFh
	BA263	64 kwords	1070000h-107FFFFh
	BA262	64 kwords	1060000h-106FFFFh
BA261	64 kwords	1050000h-105FFFFh	
BA260	64 kwords	1040000h-104FFFFh	
BA259	64 kwords	1030000h-103FFFFh	

Bank	Block	Block Size	(x16) Address Range
Bank 7	BA258	64 kwords	1020000h-102FFFFh
	BA257	64 kwords	1010000h-101FFFFh
	BA256	64 kwords	1000000h-100FFFFh
Bank 8	BA255	64 kwords	0FF0000h-0FFFFFFh
	BA254	64 kwords	0FE0000h-0FEFFFFh
	BA253	64 kwords	0FD0000h-0FDFFFFh
	BA252	64 kwords	0FC0000h-0FCFFFFh
	BA251	64 kwords	0FB0000h-0FBFFFFh
	BA250	64 kwords	0FA0000h-0FAFFFFh
	BA249	64 kwords	0F90000h-0F9FFFFh
	BA248	64 kwords	0F80000h-0F8FFFFh
	BA247	64 kwords	0F70000h-0F7FFFFh
	BA246	64 kwords	0F60000h-0F6FFFFh
	BA245	64 kwords	0F50000h-0F5FFFFh
	BA244	64 kwords	0F40000h-0F4FFFFh
	BA243	64 kwords	0F30000h-0F3FFFFh
	BA242	64 kwords	0F20000h-0F2FFFFh
	BA241	64 kwords	0F10000h-0F1FFFFh
	BA240	64 kwords	0F00000h-0F0FFFFh
	BA239	64 kwords	0EF0000h-0EFFFFFFh
	BA238	64 kwords	0EE0000h-0EEFFFFh
	BA237	64 kwords	0ED0000h-0EDFFFFh
	BA236	64 kwords	0EC0000h-0ECFFFFh
	BA235	64 kwords	0EB0000h-0EBFFFFh
	BA234	64 kwords	0EA0000h-0EAFFFFh
	BA233	64 kwords	0E90000h-0E9FFFFh
	BA232	64 kwords	0E80000h-0E8FFFFh
	BA231	64 kwords	0E70000h-0E7FFFFh
	BA230	64 kwords	0E60000h-0E6FFFFh
	BA229	64 kwords	0E50000h-0E5FFFFh
BA228	64 kwords	0E40000h-0E4FFFFh	
BA227	64 kwords	0E30000h-0E3FFFFh	
BA226	64 kwords	0E20000h-0E2FFFFh	
BA225	64 kwords	0E10000h-0E1FFFFh	
BA224	64 kwords	0E00000h-0E0FFFFh	
Bank 9	BA223	64 kwords	0DF0000h-0DFFFFFFh
	BA222	64 kwords	0DE0000h-0DEFFFFh
	BA221	64 kwords	0DD0000h-0DDFFFFh
	BA220	64 kwords	0DC0000h-0DCFFFFh
	BA219	64 kwords	0DB0000h-0DBFFFFh
	BA218	64 kwords	0DA0000h-0DAFFFFh
	BA217	64 kwords	0D90000h-0D9FFFFh
	BA216	64 kwords	0D80000h-0D8FFFFh
BA215	64 kwords	0D70000h-0D7FFFFh	
BA214	64 kwords	0D60000h-0D6FFFFh	

Bank	Block	Block Size	(x16) Address Range
Bank 9	BA213	64 kwords	0D50000h-0D5FFFFh
	BA212	64 kwords	0D40000h-0D4FFFFh
	BA211	64 kwords	0D30000h-0D3FFFFh
	BA210	64 kwords	0D20000h-0D2FFFFh
	BA209	64 kwords	0D10000h-0D1FFFFh
	BA208	64 kwords	0D00000h-0D0FFFFh
	BA207	64 kwords	0CF0000h-0CFFFFFh
	BA206	64 kwords	0CE0000h-0CEFFFFh
	BA205	64 kwords	0CD0000h-0CDFFFFh
	BA204	64 kwords	0CC0000h-0CCFFFFh
	BA203	64 kwords	0CB0000h-0CBFFFFh
	BA202	64 kwords	0CA0000h-0CAFFFFh
	BA201	64 kwords	0C90000h-0C9FFFFh
	BA200	64 kwords	0C80000h-0C8FFFFh
	BA199	64 kwords	0C70000h-0C7FFFFh
	BA198	64 kwords	0C60000h-0C6FFFFh
BA197	64 kwords	0C50000h-0C5FFFFh	
BA196	64 kwords	0C40000h-0C4FFFFh	
BA195	64 kwords	0C30000h-0C3FFFFh	
BA194	64 kwords	0C20000h-0C2FFFFh	
BA193	64 kwords	0C10000h-0C1FFFFh	
BA192	64 kwords	0C00000h-0C0FFFFh	
Bank 10	BA191	64 kwords	0BF0000h-0BFFFFFFh
	BA190	64 kwords	0BE0000h-0BEFFFFh
	BA189	64 kwords	0BD0000h-0BDFFFFh
	BA188	64 kwords	0BC0000h-0BCFFFFh
	BA187	64 kwords	0BB0000h-0BBFFFFh
	BA186	64 kwords	0BA0000h-0BAFFFFh
	BA185	64 kwords	0B90000h-0B9FFFFh
	BA184	64 kwords	0B80000h-0B8FFFFh
	BA183	64 kwords	0B70000h-0B7FFFFh
	BA182	64 kwords	0B60000h-0B6FFFFh
	BA181	64 kwords	0B50000h-0B5FFFFh
	BA180	64 kwords	0B40000h-0B4FFFFh
	BA179	64 kwords	0B30000h-0B3FFFFh
	BA178	64 kwords	0B20000h-0B2FFFFh
	BA177	64 kwords	0B10000h-0B1FFFFh
	BA176	64 kwords	0B00000h-0B0FFFFh
BA175	64 kwords	0AF0000h-0AFFFFFFh	
BA174	64 kwords	0AE0000h-0AEFFFFh	
BA173	64 kwords	0AD0000h-0ADFFFFh	
BA172	64 kwords	0AC0000h-0ACFFFFh	
BA171	64 kwords	0AB0000h-0ABFFFFh	
BA170	64 kwords	0AA0000h-0AAFFFFh	
BA169	64 kwords	0A90000h-0A9FFFFh	

Bank	Block	Block Size	(x16) Address Range
Bank 10	BA168	64 kwords	0A80000h-0A8FFFFh
	BA167	64 kwords	0A70000h-0A7FFFFh
	BA166	64 kwords	0A60000h-0A6FFFFh
	BA165	64 kwords	0A50000h-0A5FFFFh
	BA164	64 kwords	0A40000h-0A4FFFFh
	BA163	64 kwords	0A30000h-0A3FFFFh
	BA162	64 kwords	0A20000h-0A2FFFFh
	BA161	64 kwords	0A10000h-0A1FFFFh
	BA160	64 kwords	0A00000h-0A0FFFFh
Bank 11	BA159	64 kwords	09F0000h-09FFFFh
	BA158	64 kwords	09E0000h-09EFFFFh
	BA157	64 kwords	09D0000h-09DFFFFh
	BA156	64 kwords	09C0000h-09CFFFFh
	BA155	64 kwords	09B0000h-09BFFFFh
	BA154	64 kwords	09A0000h-09AFFFFh
	BA153	64 kwords	0990000h-099FFFFh
	BA152	64 kwords	0980000h-098FFFFh
	BA151	64 kwords	0970000h-097FFFFh
	BA150	64 kwords	0960000h-096FFFFh
	BA149	64 kwords	0950000h-095FFFFh
	BA148	64 kwords	0940000h-094FFFFh
	BA147	64 kwords	0930000h-093FFFFh
	BA146	64 kwords	0920000h-092FFFFh
	BA145	64 kwords	0910000h-091FFFFh
	BA144	64 kwords	0900000h-090FFFFh
	BA143	64 kwords	08F0000h-08FFFFh
	BA142	64 kwords	08E0000h-08EFFFFh
	BA141	64 kwords	08D0000h-08DFFFFh
	BA140	64 kwords	08C0000h-08CFFFFh
	BA139	64 kwords	08B0000h-08BFFFFh
	BA138	64 kwords	08A0000h-08AFFFFh
	BA137	64 kwords	0890000h-089FFFFh
	BA136	64 kwords	0880000h-088FFFFh
	BA135	64 kwords	0870000h-087FFFFh
	BA134	64 kwords	0860000h-086FFFFh
	BA133	64 kwords	0850000h-085FFFFh
	BA132	64 kwords	0840000h-084FFFFh
	BA131	64 kwords	0830000h-083FFFFh
	BA130	64 kwords	0820000h-082FFFFh
BA129	64 kwords	0810000h-081FFFFh	
BA128	64 kwords	0800000h-080FFFFh	
Bank 12	BA127	64 kwords	07F0000h-07FFFFh
	BA126	64 kwords	07E0000h-07EFFFFh
	BA125	64 kwords	07D0000h-07DFFFFh
	BA124	64 kwords	07C0000h-07CFFFFh

Bank	Block	Block Size	(x16) Address Range
Bank 12	BA123	64 kwords	07B0000h-07BFFFFh
	BA122	64 kwords	07A0000h-07AFFFFh
	BA121	64 kwords	0790000h-079FFFFh
	BA120	64 kwords	0780000h-078FFFFh
	BA119	64 kwords	0770000h-077FFFFh
	BA118	64 kwords	0760000h-076FFFFh
	BA117	64 kwords	0750000h-075FFFFh
	BA116	64 kwords	0740000h-074FFFFh
	BA115	64 kwords	0730000h-073FFFFh
	BA114	64 kwords	0720000h-072FFFFh
	BA113	64 kwords	0710000h-071FFFFh
	BA112	64 kwords	0700000h-070FFFFh
	BA111	64 kwords	06F0000h-06FFFFh
	BA110	64 kwords	06E0000h-06EFFFFh
	BA109	64 kwords	06D0000h-06DFFFFh
	BA108	64 kwords	06C0000h-06CFFFFh
	BA107	64 kwords	06B0000h-06BFFFFh
	BA106	64 kwords	06A0000h-06AFFFFh
	BA105	64 kwords	0690000h-069FFFFh
	BA104	64 kwords	0680000h-068FFFFh
	BA103	64 kwords	0670000h-067FFFFh
	BA102	64 kwords	0660000h-066FFFFh
	BA101	64 kwords	0650000h-065FFFFh
	BA100	64 kwords	0640000h-064FFFFh
Bank 13	BA99	64 kwords	0630000h-063FFFFh
	BA98	64 kwords	0620000h-062FFFFh
	BA97	64 kwords	0610000h-061FFFFh
	BA96	64 kwords	0600000h-060FFFFh
	BA95	64 kwords	05F0000h-05FFFFh
	BA94	64 kwords	05E0000h-05EFFFFh
	BA93	64 kwords	05D0000h-05DFFFFh
	BA92	64 kwords	05C0000h-05CFFFFh
	BA91	64 kwords	05B0000h-05BFFFFh
	BA90	64 kwords	05A0000h-05AFFFFh
	BA89	64 kwords	0590000h-059FFFFh
	BA88	64 kwords	0580000h-058FFFFh
	BA87	64 kwords	0570000h-057FFFFh
	BA86	64 kwords	0560000h-056FFFFh
	BA85	64 kwords	0550000h-055FFFFh
	BA84	64 kwords	0540000h-054FFFFh
BA83	64 kwords	0530000h-053FFFFh	
BA82	64 kwords	0520000h-052FFFFh	
BA81	64 kwords	0510000h-051FFFFh	
BA80	64 kwords	0500000h-050FFFFh	

Bank	Block	Block Size	(x16) Address Range
Bank 13	BA79	64 kwords	04F0000h-04FFFFFFh
	BA78	64 kwords	04E0000h-04EFFFFFFh
	BA77	64 kwords	04D0000h-04DFFFFFFh
	BA76	64 kwords	04C0000h-04CFFFFFFh
	BA75	64 kwords	04B0000h-04BFFFFFFh
	BA74	64 kwords	04A0000h-04AFFFFFFh
	BA73	64 kwords	0490000h-049FFFFFFh
	BA72	64 kwords	0480000h-048FFFFFFh
	BA71	64 kwords	0470000h-047FFFFFFh
	BA70	64 kwords	0460000h-046FFFFFFh
	BA69	64 kwords	0450000h-045FFFFFFh
	BA68	64 kwords	0440000h-044FFFFFFh
	BA67	64 kwords	0430000h-043FFFFFFh
	BA66	64 kwords	0420000h-042FFFFFFh
Bank 14	BA65	64 kwords	0410000h-041FFFFFFh
	BA64	64 kwords	0400000h-040FFFFFFh
	BA63	64 kwords	03F0000h-03FFFFFFh
	BA62	64 kwords	03E0000h-03EFFFFFFh
	BA61	64 kwords	03D0000h-03DFFFFFFh
	BA60	64 kwords	03C0000h-03CFFFFFFh
	BA59	64 kwords	03B0000h-03BFFFFFFh
	BA58	64 kwords	03A0000h-03AFFFFFFh
	BA57	64 kwords	0390000h-039FFFFFFh
	BA56	64 kwords	0380000h-038FFFFFFh
	BA55	64 kwords	0370000h-037FFFFFFh
	BA54	64 kwords	0360000h-036FFFFFFh
	BA53	64 kwords	0350000h-035FFFFFFh
	BA52	64 kwords	0340000h-034FFFFFFh
	BA51	64 kwords	0330000h-033FFFFFFh
	BA50	64 kwords	0320000h-032FFFFFFh
	BA49	64 kwords	0310000h-031FFFFFFh
	BA48	64 kwords	0300000h-030FFFFFFh
	BA47	64 kwords	02F0000h-02FFFFFFFh
	BA46	64 kwords	02E0000h-02EFFFFFFh
BA45	64 kwords	02D0000h-02DFFFFFFh	
BA44	64 kwords	02C0000h-02CFFFFFFh	
BA43	64 kwords	02B0000h-02BFFFFFFh	
BA42	64 kwords	02A0000h-02AFFFFFFh	
BA41	64 kwords	0290000h-029FFFFFFh	
BA40	64 kwords	0280000h-028FFFFFFh	
BA39	64 kwords	0270000h-027FFFFFFh	
BA38	64 kwords	0260000h-026FFFFFFh	
BA37	64 kwords	0250000h-025FFFFFFh	
BA36	64 kwords	0240000h-024FFFFFFh	
BA35	64 kwords	0230000h-023FFFFFFh	

Bank	Block	Block Size	(x16) Address Range
Bank 14	BA34	64 kwords	0220000h-022FFFFh
	BA33	64 kwords	0210000h-021FFFFh
	BA32	64 kwords	0200000h-020FFFFh
Bank 15	BA31	64 kwords	01F0000h-01FFFFFFh
	BA30	64 kwords	01E0000h-01EFFFFh
	BA29	64 kwords	01D0000h-01DFFFFh
	BA28	64 kwords	01C0000h-01CFFFFh
	BA27	64 kwords	01B0000h-01BFFFFh
	BA26	64 kwords	01A0000h-01AFFFFh
	BA25	64 kwords	0190000h-019FFFFh
	BA24	64 kwords	0180000h-018FFFFh
	BA23	64 kwords	0170000h-017FFFFh
	BA22	64 kwords	0160000h-016FFFFh
	BA21	64 kwords	0150000h-015FFFFh
	BA20	64 kwords	0140000h-014FFFFh
	BA19	64 kwords	0130000h-013FFFFh
	BA18	64 kwords	0120000h-012FFFFh
	BA17	64 kwords	0110000h-011FFFFh
	BA16	64 kwords	0100000h-010FFFFh
	BA15	64 kwords	00F0000h-00FFFFFFh
	BA14	64 kwords	00E0000h-00EFFFFh
	BA13	64 kwords	00D0000h-00DFFFFh
	BA12	64 kwords	00C0000h-00CFFFFh
	BA11	64 kwords	00B0000h-00BFFFFh
	BA10	64 kwords	00A0000h-00AFFFFh
	BA9	64 kwords	0090000h-009FFFFh
	BA8	64 kwords	0080000h-008FFFFh
	BA7	64 kwords	0070000h-007FFFFh
	BA6	64 kwords	0060000h-006FFFFh
	BA5	64 kwords	0050000h-005FFFFh
BA4	64 kwords	0040000h-004FFFFh	
BA3	64 kwords	0030000h-003FFFFh	
BA2	64 kwords	0020000h-002FFFFh	
BA1	64 kwords	0010000h-001FFFFh	
BA0	64 kwords	0000000h-000FFFFh	

[Table 22] Uniform OTP Block Addresses

OTP	Block Address A24 ~ A8	Block Size	(x16) Address Range*
	1FFFFh	512 words	1FFFE00h-1FFFFFFh

After entering OTP Block, any issued addresses should be in the range of OTP block address.