

## Phase Control Thyristor Chips

Type	$V_{\text{max}}$ $V_{\text{max}}$ V	$I_{\text{p}}$ , $I_{\text{p}}$ typ 125°C mA	$I_{\text{GT}}$ 25°C mA	$V_{\text{T}}$ @ $I_{\text{T}}$ $T_{\text{T}} = 25^{\circ}\text{C}$		$V_{\text{TO}}$ V	$r_{\text{T}}$ mΩ	$I_{\text{SM}}$ @ 10 ms 45°C A	$I_{\text{TAVG}}$ @ $T_{\text{T}} = 125^{\circ}\text{C}$ $T_{\text{T}} = 75^{\circ}\text{C}$ A	$R_{\text{th}}$ KW	Chips per Wafer 100 mm Ø	Fig.
				V	A							
CWP 7 - 08/12 <sup>③</sup>	800 - 1200	1	25	1.45	20	0.90	32.0	200	10	2.3	326	2
CWP 8 - 08/12	800 - 1200	1	30	1.55	44	0.90	18.0	300	19	1.65	229	1
CWP 16 - 12/16	1200 - 1600	2	50	1.42	45	0.90	13.5	400	24	1.38	148	2
CWP 22 - 12/16	1200 - 1600	3	50	1.41	60	0.85	10.0	520	30	1.15	120	2
CWP 25 - 12/16	1200 - 1600	3	50	1.35	60	0.85	8.0	600	35	1.03	120	1
CWP 35 - 08/12	800 - 1200	5	100	1.48	150	0.85	4.6	1200	52	0.74	76	1
CWP 41 - 12/18	1200 - 1800	10	150	1.55	200	0.85	4.0	1150	57	0.68	57	1
CWP 50 - 12/18	1200 - 1800	10	150	1.39	200	0.80	2.95	1500	74	0.56	47	1
CWP 55 - 12/18	1200 - 1800	10	150	1.31	200	0.80	2.3	1900	88	0.48	37	1
CWP 71 - 12/18	1200 - 1800	10	150	1.36	300	0.80	1.82	2400	100	0.42	32	1
CWP180 - 12/18	1200 - 1800	15	150	1.25	450	0.80	0.850	5200	180	0.26	16	1
CWP341 - 12/18	1200 - 1800	15	150	1.24	600	0.80	0.627	7200	220	0.218	11	1
CWP347 - 12/18	1200 - 1800	20	150	1.20	600	0.80	0.530	8200	250	0.195	9	1

### High Voltage Phase Control Thyristor Chips

CWP 69 - 12/22	1200 - 2200	10	150	1.57	300	0.80	2.5	2000	93	0.43	32	1
CWP339 - 12/22	1200 - 2200	15	150	1.29	300	0.80	0.80	6500	205	0.22	11	1
CWP345 - 12/22	1200 - 2200	20	150	1.36	600	0.80	0.67	8000	230	0.20	9	1

① Specified values refer to chips only, assembly parts are not included

② Specified values can only be obtained in void-free assemblies according to our assembly recommendations!

③ Preliminary data

# Phase Control Thyristor Chips

Fig. 1

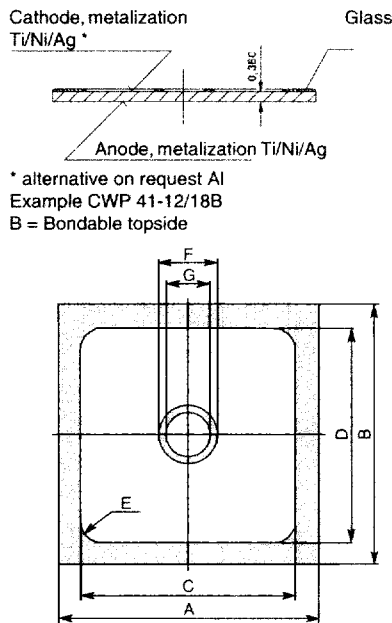
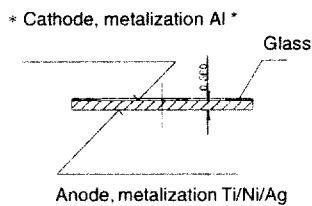

Fig. 2



\* alternative on request Ti/Ni/Ag  
Example: CWP 16-12/16S  
S = Solderable topside

### Dimensions in mm

Type	thickn. mm	A mm	B mm	C mm	D mm	E mm	F mm	G mm
CWP 8-08/12	0.38	5.2	5.20	3.70	3.70	0.30	1.8	0.9
CWP 25-12/16		7.1	7.10	5.22	5.22	0.30	1.8	1.0
CWP 35-08/12		8.7	8.70	6.80	6.80	0.30	1.8	1.0
CWP 41-12/18		10.0	10.00	7.43	7.43	0.40	2.3	1.5
CWP 50-12/18		13.0	9.77	10.43	7.20	0.72	2.3	1.5
CWP 55-12/18		12.3	12.30	9.73	9.73	0.40	2.3	1.5
CWP 71-12/18		13.4	13.40	10.83	10.83	0.50	2.3	1.5
CWP180-12/18		20.5	17.65	18.00	15.10	2.50	3.5	2.5
CWP341-12/18		25.3	18.50	22.72	15.92	3.30	3.5	2.5
CWP347-12/18		23.4	23.40	20.83	20.83	3.92	3.5	2.5
<b>High Voltage</b> CWP 69-12/22	0.46	13.4	13.40	10.60	10.60	0.30	2.3	1.5
CWP339-12/22		25.3	18.50	22.50	15.70	2.10	3.5	2.5
CWP345-12/22		23.4	23.40	20.60	20.60	3.80	2.5	2.5
<b>Tolerance</b>		-0.1	-0.1	+0.1	+0.1	+0.1	-0.1	+0.1

### Dimensions in inch

Type	thickn. inch	A inch	B inch	C inch	D inch	E inch	F inch	G inch
CWP 8-08/12	0.015	0.205	0.205	0.146	0.146	0.012	0.071	0.035
CWP 25-12/16		0.280	0.280	0.009	0.206	0.012	0.071	0.039
CWP 35-08/12		0.343	0.343	0.268	0.268	0.012	0.071	0.039
CWP 41-12/18		0.394	0.394	0.293	0.293	0.016	0.091	0.059
CWP 50-12/18		0.512	0.385	0.411	0.283	0.028	0.091	0.059
CWP 55-12/18		0.484	0.484	0.383	0.383	0.016	0.091	0.059
CWP 71-12/18		0.528	0.528	0.426	0.426	0.020	0.091	0.059
CWP180-12/18		0.809	0.695	0.709	0.594	0.096	0.138	0.098
CWP341-12/18		0.996	0.728	0.894	0.627	0.130	0.138	0.098
CWP347-12/18		0.921	0.921	0.820	0.820	0.154	0.138	0.098
<b>High Voltage</b> CWP 69-12/22	0.018	0.528	0.528	0.418	0.418	0.012	0.091	0.059
CWP339-12/22		0.996	0.728	0.886	0.619	0.087	0.138	0.098
CWP345-12/22		0.921	0.921	0.812	0.812	0.150	0.098	0.098
<b>Tolerance</b>		-0.004	-0.004	+0.004	+0.004	+0.004	-0.004	+0.004

### Dimensions in mm

Type	thickn. mm	A mm	B mm	C mm	D mm	E mm	H mm	J mm	K mm	L mm
CWP 7-08/12	0.38	4.45	4.45	3.02	3.02	0.300	1.50	0.25	0.25	1.00
CWP 16-12/16	0.38	6.50	6.50	4.32	4.32	0.340	1.50	0.40	0.40	1.50
CWP 22-12/16	0.38	7.10	7.10	4.92	4.92	0.340	1.50	0.40	0.40	1.50
<b>Tolerance</b>		-0.1	-0.1	+0.1	+0.1	+0.1	+0.1	-0.1	-0.1	+0.1

### Dimensions in inch

Type	thickn. mm	A mm	B mm	C mm	D mm	E mm	H mm	J mm	K mm	L mm
CWP 7-08/12	0.015	0.175	0.175	0.119	0.119	0.012	0.059	0.010	0.010	0.039
CWP 16-12/16	0.015	0.256	0.256	0.170	0.170	0.013	0.059	0.016	0.016	0.059
CWP 22-12/16	0.015	0.280	0.280	0.194	0.194	0.013	0.059	0.016	0.016	0.059
<b>Tolerance</b>		-0.004	-0.004	+0.004	+0.001	+0.004	+0.004	-0.004	-0.004	+0.004