



## 1A VERY LOW DROPOUT POSITIVE FIXED AND ADJUSTABLE REGULATORS

### FEATURES

- Low Dropout Voltage (500mV at 1A)
- 1% Voltage Reference Accuracy
- Low Ground Current
- 1 $\mu$ A Maximum Quiescent Current in Shutdown (APU1207, APU1208)
- Fast Transient Response
- Current Limit and Thermal Shutdown
- Error Flag Signal for Output out of Regulation (APU1207, APU1208)
- RoHS Compliant

### APPLICATIONS

- 2.5V Supply from 3.3V Input for the new generation of Logic ICs
- Computer Mother Board, Add-On Cards
- High Efficiency Post Regulator in Switch Mode Power Supply (SMPS)

### DESCRIPTION

The APU1206 family of devices are ultra low dropout 1A regulators using PNP transistor as the pass element. These products are ideal when a single input supply is only available and the dropout voltage is less than 1V, exceeding the minimum dropout characteristics of NPN/PNP hybrid regulators. One common application of these regulators is where input is 3.3V and a 2.5V output is needed.

Besides the low dropout of less than 0.5V, other features of the family of the parts are: micro-power shut-down capability and output UVLO detection where Flag pin is switched low when output is below 5% of its nominal point.

### TYPICAL APPLICATION

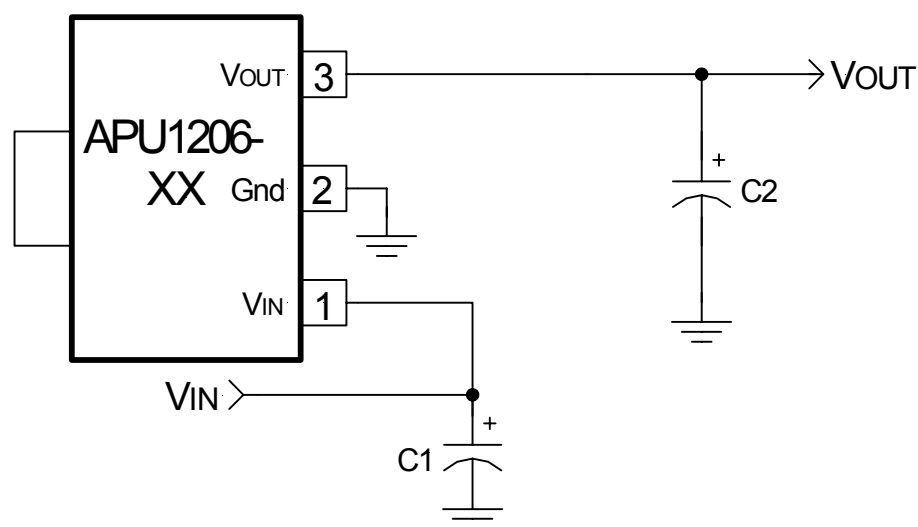

Figure 1 - Typical application of the 1206-XX in a 3-Pin SOT-223 package.



## PACKAGE ORDER INFORMATION

### Basic Part

T <sub>J</sub> (°C)	2-PIN TO-252(H)	3-PIN SOT-223(K)	8-PIN PLASTIC SOIC(M)	VOLTAGE	PIN FUNCTIONS
0 To 125	APU1206H-18	APU1206K-18	NA	1.8V	V <sub>IN</sub> , V <sub>OUT</sub> , Gnd
0 To 125	APU1206H-25	APU1206K-25	NA	2.5V	V <sub>IN</sub> , V <sub>OUT</sub> , Gnd
0 To 125	APU1206H-33	APU1206K-33	NA	3.3V	V <sub>IN</sub> , V <sub>OUT</sub> , Gnd
0 To 125	NA	NA	APU1207M-18	1.8V	V <sub>IN</sub> , V <sub>OUT</sub> , Gnd, Enable, Flag
0 To 125	NA	NA	APU1207M-25	2.5V	V <sub>IN</sub> , V <sub>OUT</sub> , Gnd, Enable, Flag
0 To 125	NA	NA	APU1207M-33	3.3V	V <sub>IN</sub> , V <sub>OUT</sub> , Gnd, Enable, Flag
0 To 125	NA	NA	APU1208M	Adj	V <sub>IN</sub> , V <sub>OUT</sub> , Gnd, Flag, Adj
0 To 125	NA	NA	APU1209M	Adj	V <sub>IN</sub> , V <sub>OUT</sub> , Gnd, Enable, Adj



**ABSOLUTE MAXIMUM RATINGS**

Input Voltage (V <sub>IN</sub> ) .....	10V
Enable Input Voltage .....	10V
Storage Temperature Range .....	-65°C To 150°C
Operating Junction Temperature Range .....	0°C To 135°C

**PACKAGE INFORMATION**

<p>2-PIN PLASTIC TO-252 (D-Pak)</p>	<p>3-PIN PLASTIC SOT-223 (K)</p>
<p>8-PIN PLASTIC SOIC (M)</p>	
<p>APU1207</p>	<p>APU1208</p>
<p>APU1209</p>	

**ELECTRICAL SPECIFICATIONS**

Unless otherwise specified, these specifications apply over C<sub>IN</sub>=C<sub>OUT</sub>=10μF, V<sub>IN</sub>=V<sub>O</sub>+1V, V<sub>OUT</sub>=V<sub>FB</sub> (For adjustable version only), and T<sub>A</sub>=25°C. Typical values refer to T<sub>A</sub>=25°C. Low duty cycle pulse testing is used which keeps junction and case temperatures equal to the ambient temperature.

PARAMETER	SYM	TEST CONDITION	MIN	TYP	MAX	UNITS
Initial Voltage Accuracy (see Table 1 for nominal values)	V <sub>O</sub>	I <sub>O</sub> =10mA, T <sub>A</sub> =25 (Note 4)	-1 -1.3		1 1.3	%
Line Regulation	ΔV <sub>I</sub>	V <sub>O</sub> + 1V < V <sub>IN</sub> < 10		0.5	1	%
Load Regulation (Note 1)	ΔV <sub>L</sub>	10mA < I <sub>O</sub> < 1A 1mA < I <sub>O</sub> < 150mA		0.5	0.7 0.5	%
Output Voltage Temp Coef.	ΔV <sub>O(T)</sub>			20	100	ppm/
Dropout Voltage (Note 2)	ΔV <sub>I(O)</sub>	I <sub>O</sub> =100mA (Note 4) I <sub>O</sub> =500mA (Note 4) I <sub>O</sub> =1000mA (Note 4)		100 300 500	200 400 650	mV
Ground Current (Note 3)	I <sub>G</sub>	V <sub>IN</sub> =V <sub>O</sub> + 1 for all conditions: I <sub>O</sub> =100mA (Note 4) I <sub>O</sub> =500mA (Note 4) I <sub>O</sub> =1000mA (Note 4)			3 15 50	mA
Current Limit	I <sub>CL</sub>	V <sub>O</sub> =5% Below Regulation Point	1.1	1.4		A
Minimum Input Voltage	V <sub>IN(min)</sub>			2.1	2.3	V
<b>APU1208, APU1209</b>						
Adjust Pin Current	I <sub>ADJ</sub>	V <sub>IN</sub> =2.5V, V <sub>O</sub> =V <sub>ADJ</sub> (Note 4)			0.1	μA
Minimum Load Current	I <sub>O(min)</sub>		1			mA



PARAMETER	SYM	TEST CONDITION	MIN	TYP	MAX	UNITS
<b>APU1207, APU1209</b>						
Ground Current - SD Activated	$I_{Q(SD)}$	Enable=Open		0.01	1	$\mu A$
Enable Pin Input LO Voltage	$V_{EN(L)}$	Regulator OFF (Note 4)			0.8	V
Enable Pin Input HI Voltage	$V_{EN(L)}$	Regulator ON (Note 4)	2			V
Enable Pin Input LO Current		$V_{EN(L)}=0V$ to 0.8V (Note 4)		0.1	2	$\mu A$
Enable Pin Input HI Current		$V_{EN(L)}=2V$ to $V_{in}$ (Note 4)		100	600	$\mu A$
<b>APU1207, APU1208</b>						
Flag Output Threshold Voltage	$V_{TH(FG)}$			5		$\%V_O$
Flag Output Hysteresis Voltage	$V_{HYS}$	Output Ramping Up		0.8		$\%V_O$
Flag Output Saturation Voltage	$V_{F(SAT)}$	$I_o=5mA$ $I_o=500\mu A$		400 230		mV

**Note 1:** Low duty cycle pulse testing with Kelvin connections is required in order to maintain accurate data.

**Note 2:** Dropout voltage is defined as the minimum differential voltage between  $V_{IN}$  and  $V_{OUT}$  required to maintain regulation at  $V_{OUT}$ . It is measured when the output voltage drops 1% below its nominal value.

**Note 3:** Ground current is the regulator quiescent current plus the pass transistor current. The total current from the supply is the sum of the load current plus the ground pin current.

**Note 4:** The specification applies for the junction temperature of 0 to +125.

## PIN DESCRIPTIONS

PIN SYMBOL	PIN DESCRIPTION
$V_{IN}$ (All devices)	The input pin of the regulator. Typically a large storage capacitor is connected from this pin to ground to insure that the input voltage does not sag below the minimum drop out voltage during the load transient response. This pin must always be 0.6V higher than $V_{OUT}$ in order for the device to regulate properly.
$V_{OUT}$ (All devices)	The output of the regulator. A minimum of 2.2 $\mu F$ capacitor must be connected from this pin to ground.
Gnd (All devices)	Ground pin. This pin must be connected to the lowest potential in the system and all other pins must be at higher potential with respect to this pin.
Enable (APU1207, APU1209)	Enable pin. A low signal or left open on this pin shuts down the output. This pin must be tied HI or to $V_{IN}$ for normal operation.
Flag (APU1207, APU1208)	An open collector output that switches low when the output voltage drops about 4% below its expected regulated voltage.
Adj (APU1208, APU1209)	A resistor divider from this pin to the $V_{OUT}$ pin and ground sets the output voltage.

## APPLICATION INFORMATION

### Stability

The APU120X series of regulators require the use of an output capacitor as part of the frequency compensation in order to make the regulator stable. A minimum of 2.2 $\mu F$  capacitance and the ESR in the range of 0.5 to 2  $\Omega$  insures the stability of the system.

Part Number	Output Voltage
APU1206-18	1.8V
APU1206-25	2.5V
APU1206-33	3.3V
APU1207-18	1.8V
APU1207-25	2.5V
APU1207-33	3.3V
APU1208	1.24V
APU1209	1.24V

Table 1 - Output voltage vs. part number.



TYPICAL APPLICATION

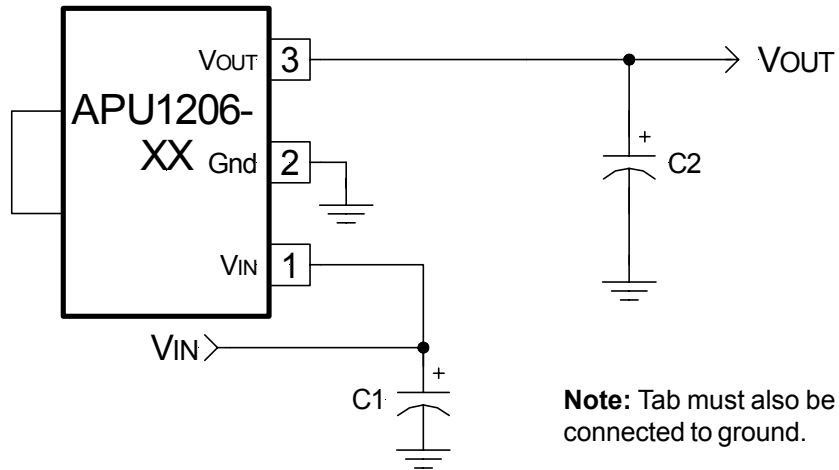

Figure 2 - Typical application of APU1206.

Ref Desig	Description	Qty	Part #	Manuf
C1	Capacitor	1	10µF, Tantalum	AVX
C2	Capacitor	1	10µF, Tantalum	AVX

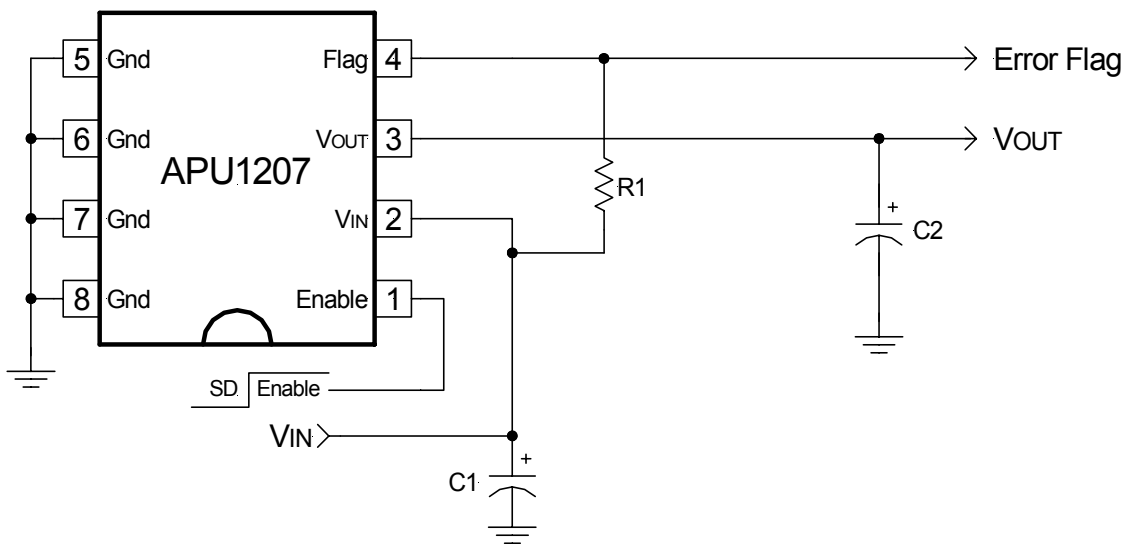

Figure 3 - Typical application of APU1207.

Ref Desig	Description	Qty	Part #	Manuf
C1	Capacitor	1	10µF, Tantalum	AVX
C2	Capacitor	1	10µF, Tantalum	AVX
R1	Resistor	1	10K ,5%	Panasonic



TYPICAL APPLICATION

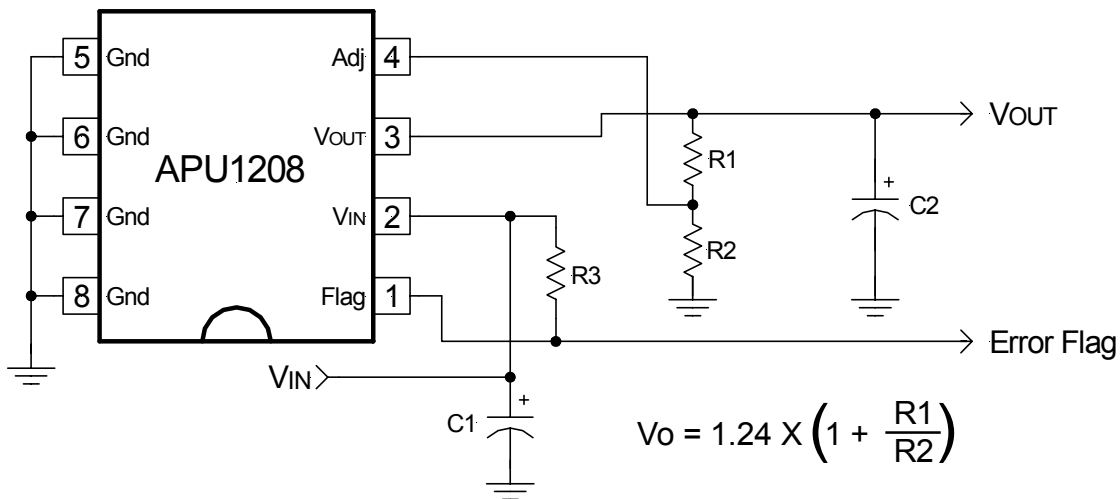

Figure 4 - Typical application of APU1208 in 3.3V to 2.5V regulator.

Ref Desig	Description	Qty	Part #	Manuf
C1	Capacitor	1	10μF, Tantalum	AVX
C2	Capacitor	1	10μF, Tantalum	AVX
R1	Resistor	1	127 , 1%	
R2	Resistor	1	124 , 1%	
R3	Resistor	1	10K , 5%	



### TYPICAL APPLICATION

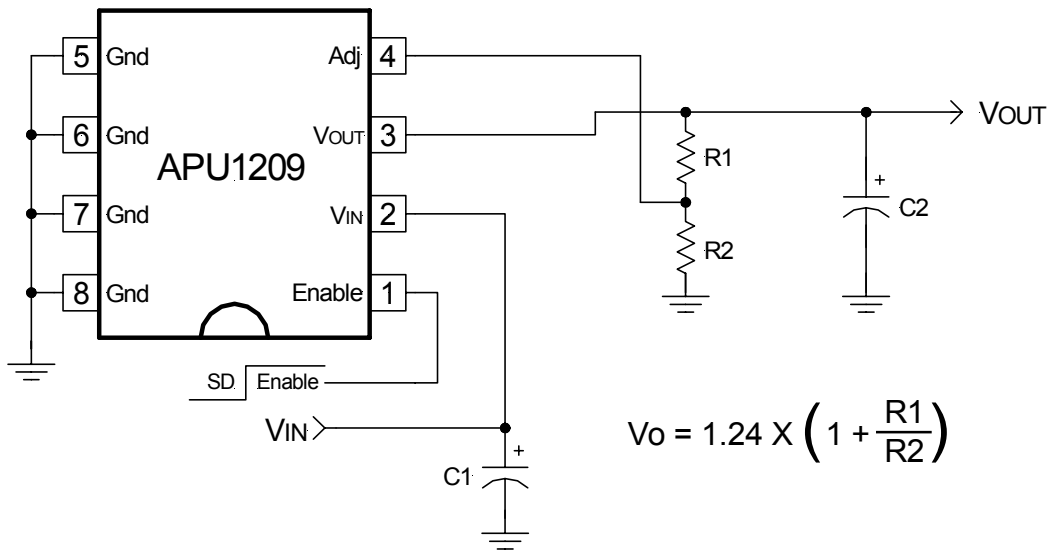

Figure 5 - Typical application of APU1209 in 3.3V to 2.5V regulator.

Ref Desig	Description	Qty	Part #	Manuf
C1	Capacitor	1	10 $\mu$ F, Tantalum	AVX
C2	Capacitor	1	10 $\mu$ F, Tantalum	AVX
R1	Resistor	1	127 , 1%	
R2	Resistor	1	124 , 1%	



CHARACTERISTICS

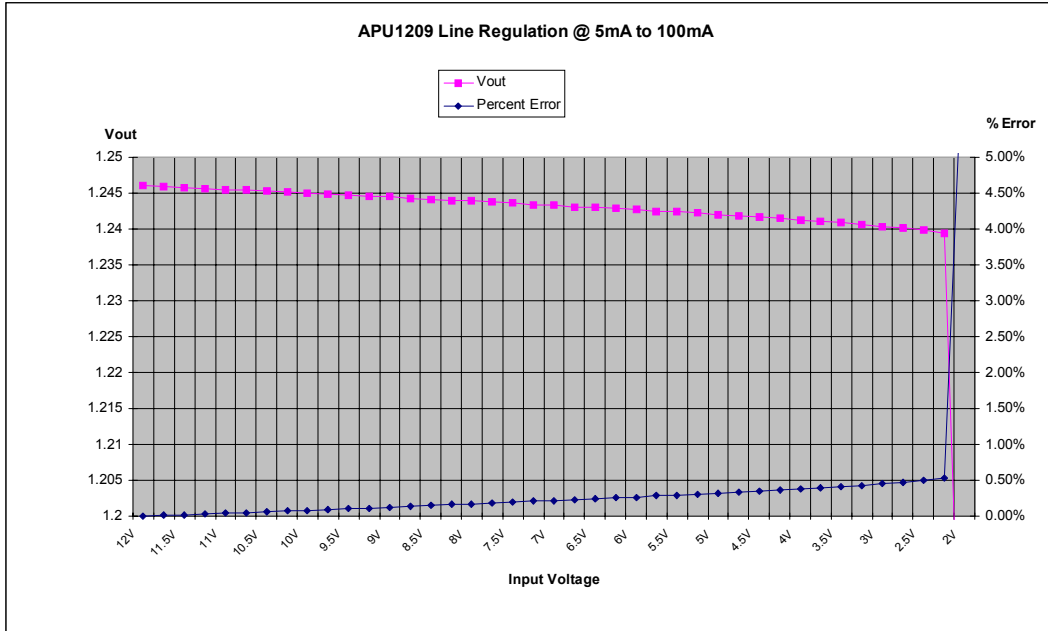

Figure 6

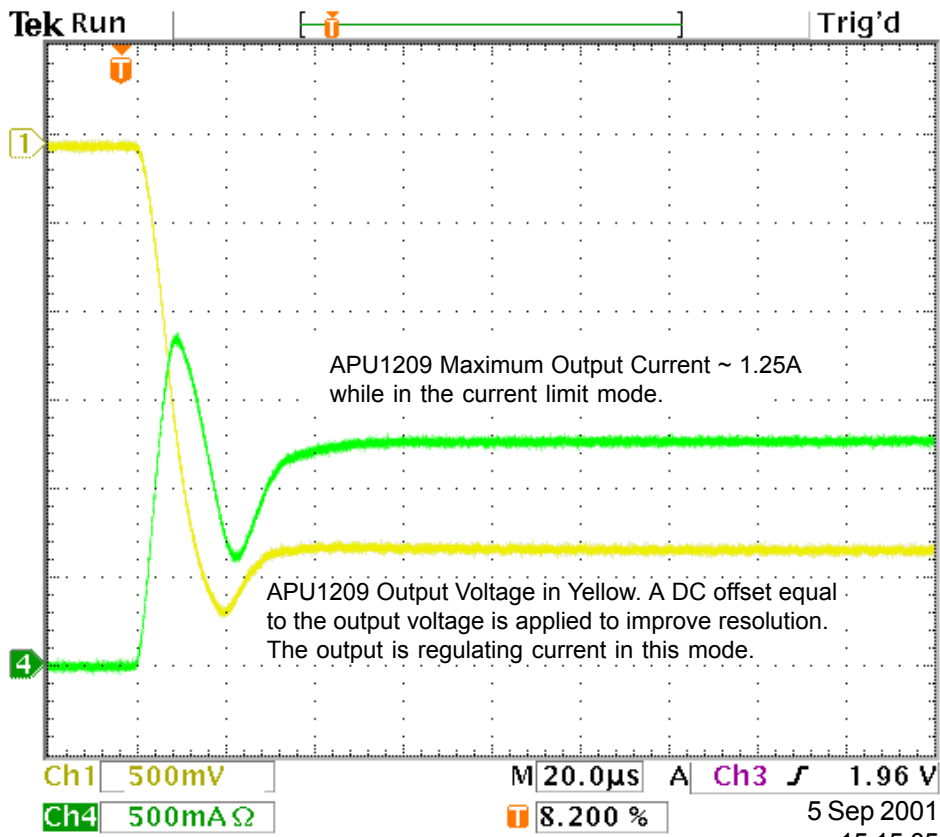

Figure 7





### CHARACTERISTICS

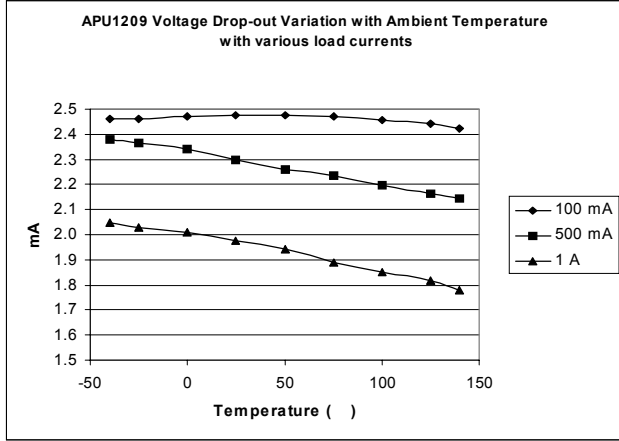

Figure 8

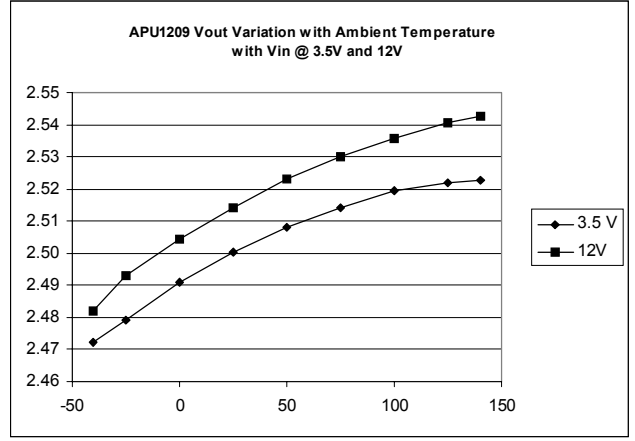

Figure 9

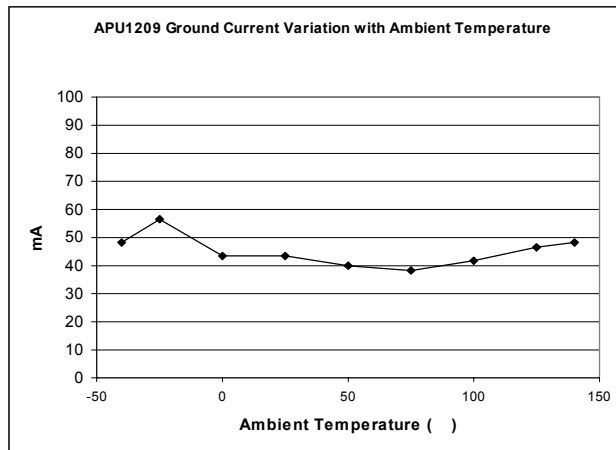

Figure 10