

RDC50 Radial Drum Core Inductors

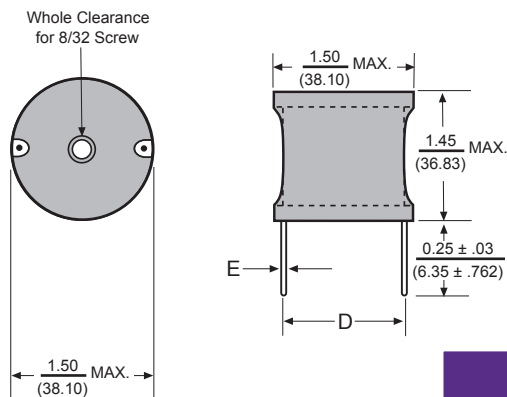

Dimensions: $\frac{\text{Inches}}{\text{(mm)}}$



Features

- High Current / Power Line Choke
- Drum Core Design
- UL VW-1 Shrink Tube Cover

Electrical

Inductance Range: 1.8 μ H to 560 μ H

Tolerance: 10% over entire range

Operating Temp: -55°C ~ +125°C

Saturation Current: Lowers Inductance by 5%

Test Equipment

(L): HP 4263A

(DCR): HP 4263A

Physical

Packaging: Box Trays

Marking: EIA Inductance Code

Allied Part Number	(L) (μ H)	Tolerance	DCR Max. (Ω)	Saturation Current (A) DC	Rated Current (A)	Dimension (D)	Dimension (E)
RDC50-1R8K-RC	1.8	10	.002	155.0	35.0	1.11	0.105
RDC50-2R2K-RC	2.2	10	.002	155.0	35.0	1.11	0.105
RDC50-2R7K-RC	2.7	10	.002	125.0	35.0	1.11	0.105
RDC50-3R3K-RC	3.3	10	.002	125.0	35.0	1.11	0.105
RDC50-3R9K-RC	3.9	10	.003	102.0	35.0	1.11	0.105
RDC50-4R7K-RC	4.7	10	.003	87.0	35.0	1.11	0.105
RDC50-5R6K-RC	5.6	10	.003	87.0	35.0	1.11	0.105
RDC50-6R8K-RC	6.8	10	.003	87.0	35.0	1.11	0.105
RDC50-8R2K-RC	8.2	10	.003	76.0	35.0	1.11	0.105
RDC50-100K-RC	10	10	.004	67.0	35.0	1.11	0.105
RDC50-120K-RC	12	10	.004	60.0	35.0	1.16	0.105
RDC50-150K-RC	15	10	.005	49.0	35.0	1.16	0.105
RDC50-180K-RC	18	10	.007	45.0	27.0	1.16	0.094
RDC50-220K-RC	22	10	.007	42.0	27.0	1.16	0.094
RDC50-270K-RC	27	10	.008	35.0	27.0	1.16	0.094
RDC50-330K-RC	33	10	.009	34.0	27.0	1.16	0.094
RDC50-390K-RC	39	10	.010	30.0	27.0	1.16	0.094
RDC50-470K-RC	47	10	.011	28.0	27.4	1.16	0.094
RDC50-560K-RC	56	10	.013	26.0	21.0	1.16	0.084
RDC50-680K-RC	68	10	.015	23.0	21.0	1.25	0.084
RDC50-820K-RC	82	10	.017	20.0	21.0	1.28	0.084
RDC50-101K-RC	100	10	.018	19.0	21.0	1.25	0.084
RDC50-121K-RC	120	10	.022	18.0	17.0	1.16	0.075
RDC50-151K-RC	150	10	.025	16.0	17.0	1.16	0.075
RDC50-181K-RC	180	10	.035	14.0	13.5	1.10	0.068
RDC50-221K-RC	220	10	.040	13.0	13.5	1.10	0.068
RDC50-271K-RC	270	10	.044	11.0	13.5	1.10	0.068
RDC50-331K-RC	330	10	.049	10.0	13.5	1.11	0.068
RDC50-391K-RC	390	10	.070	9.7	11.4	1.15	0.060
RDC50-471K-RC	470	10	.078	8.8	11.4	1.07	0.060
RDC50-561K-RC	560	10	.105	8.1	9.0	1.07	0.054

All specifications subject to change without notice.