



VM7100

2, 4, 6 OR 8-CHANNEL, 5-VOLT, THIN-FILM HEAD, READ/WRITE PREAMPLIFIER

July, 1993

FEATURES

- High Performance
 - Read Gain Options Available (refer to Table 4)
 - Input Noise (refer to Table 3)
 - Head Inductance Range = 0.2 – 5 μ H
 - Write Current Range 1 - 40 mA
 - Input Capacitance (refer to Table 3)
- Low Input Capacitance Option Available, $C_{IN} = 16$ pF max
- Very Low Power Dissipation = 3 mW Typical in Sleep Mode
- Power Up/Down Data Protect Circuitry
- Reduced Write-to-Read Recovery Time
- Single Power Supply = 5 V \pm 10%
- Fault Detect Capability
- Designed for 2-Terminal Thin-Film or MIG Heads
- Optional Schottky Diode - Isolated 400 Ω Damping Resistor Available (patent pending)
- Available in 2, 4, 6 or 8-Channels

DESCRIPTION

The VM7100 is a high-performance, very low-power read/write preamplifier designed for use with external 2-terminal, thin-film or MIG recording heads. This circuit will operate on a single 5-volt power supply and is ideally suited for use in battery powered disk drives.

The VM7100 provides write current switching in the write mode and provides a low noise data path in the read mode for up to eight read/write recording heads. When deactivated, the device enters a **sleep mode** which reduces power dissipation to 3 mW. Data protection circuitry is provided to ensure that the write current source is totally disabled during power supply power up/power down conditions. Write-to-read recovery time is minimized by eliminating common mode output voltage swings when switching between modes.

The VM7100 is available in several different packages. Please consult VTC for package availability, additional read mode voltage gains and input capacitance/noise options.

CONNECTION DIAGRAMS

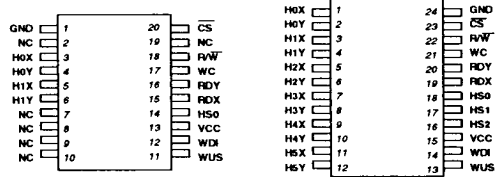

2-Channel
20-lead SSOP

6-Channel
24-lead SSOP

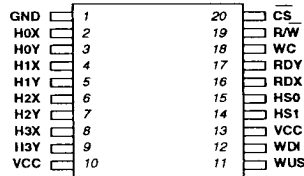

4-Channel
20-lead SOIC, SSOP, VSOP

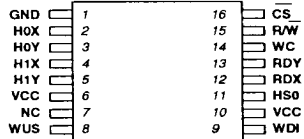

2-Channel
16-lead SOIC

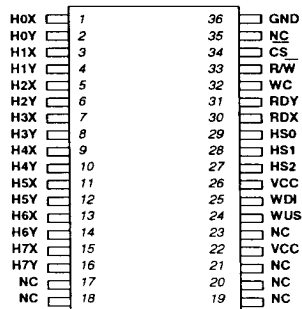

8-Channel
36-lead SOIC

THIN-FILM HEAD
& SERVO PREAMPLIFIERS

BLOCK DIAGRAM

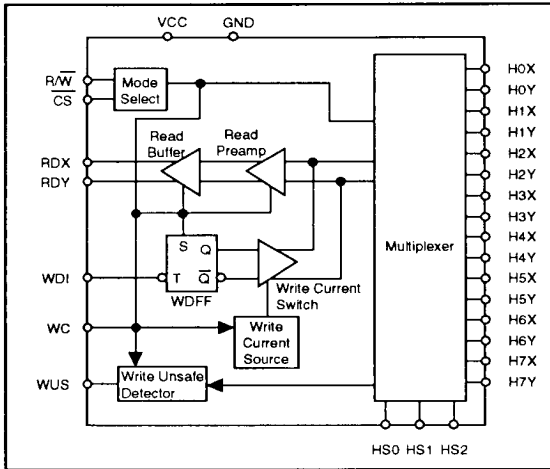

ABSOLUTE MAXIMUM RATINGS

Power Supply:	
V _{CC}	-0.3V to +7V
Write Current I _w	60mA
Input Voltages:	
Digital Input Voltage V _{IN}	-0.3V to (V _{CC} + 0.3)V
Head Port Voltage V _H	-0.3V to (V _{CC} + 0.3)V
WUS Pin Voltage Range V _{WUS}	-0.3V to +6V
Output Current:	
RDX, RDY: I _O	-10mA
WUS: I _{wus}	+12mA
Junction Temperature	150°C
Storage Temperature T _{stg}	-65° to 150°C
Thermal Characteristics, θ _{JA} :	
16-lead SOIC	100°C/W
20-lead SOIC	80°C/W
20-lead SSOP	TBD
20-lead VSOP	TBD
24-lead SSOP	TBD
36-lead SOIC	70°C/W

RECOMMENDED OPERATING CONDITIONS

Power Supply Voltage:	
V _{CC}	+5V ± 10%
Write Current (I _w)	1 to 40mA
Head Inductance (L _H)	0.2 to 10µH
Junction Temperature (T _J)	25°C to 125°C

ORDERING INFORMATION

The VM7100 part type is available with a wide variety of possible options that allow the device to closely fit different applications. In order to simplify the task of defining the various possible options, ordering information is included here. Please note, not all possible combinations of options may actually have been built. Please consult the factory with any questions.

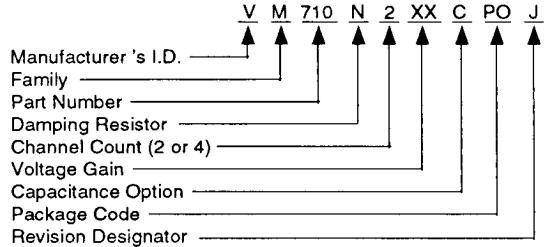

DAMPING RESISTOR

Blank = Schottky Diode Connected Damping Resistor
 N = No Internal Damping Resistor

VOLTAGE GAIN

10 = 100 Voltage Gain
 15 = 150 Voltage Gain
 20 = 200 Voltage Gain
 25 = 250 Voltage Gain
 30 = 300 Voltage Gain

CAPACITANCE OPTION (refer to Table 3)

C = Low Capacitance
 I = Intermediate Capacitance/Noise
 Blank = Low Noise

PACKAGE CODES

PO = Small Outline Integrated Circuit (SOIC)
 SS = Shrink Small Outline Package (SSOP)
 VS = Very Small Outline Package (VSOP)

CIRCUIT OPERATION

The VM7100 addresses up to four 2-terminal, thin-film recording heads, providing switched write current in the write mode, or data amplification in the read mode. Head selection and mode control is determined by the head select lines, HS1, HS2 and mode control lines, CS, R/W as shown in Tables 1 and 2. Internal resistor pullups, provided on the CS and R/W lines, will force the device into a non-write condition if either control line opens up. The part's operation over a wide range of inductive loads makes it suitable for 2-terminal MIG heads.

Write Mode

In write mode, the VM7100 acts as a write current switch with the write unsafe (WUS) detection circuitry activated. Write current is toggled between the X and Y side of the selected head on each high to low transition on the write data flip-flop (Wdff) so that upon switching to the write mode, the write current flows into the "X" side of the head.

The write current magnitude is determined by an external resistor (RWC) connected between the WC pin and ground. An

TWO/THREE TERMINAL & SERVO PREAMPLIFIERS

internally generated reference voltage is present at the WC pin. The magnitude of the Write Current (0-PK, $\pm 8\%$) is:

$$I_W = K_W/R_{WC} + 0.2\text{mA} \\ = 50/R_{WC} + 0.2\text{mA}$$

Power supply fault protection ensures data security on the disk by disabling the write current source during a power supply voltage fault or by supply power up/down conditions. Additionally, the write unsafe (WUS) detection circuitry will flag any of the conditions listed below, as a high level on the WUS line. Two negative transitions on the WDI pin, after the fault is corrected, is required to clear the WUS line.

- No write current
- WDI frequency too low
- Read or sleep mode

Read Mode

In read mode, the VM7100 acts as a low noise differential amplifier for signals coming off the disk. The write current generator and write unsafe circuitry is deactivated. The RDX, RDY pins are emitter follower outputs and are in phase with "X" and "Y" head ports. These outputs should be AC coupled to the load. The RDX, RDY common mode output voltage is constant, minimizing the transient between read and write mode, thereby, substantially reducing the recovery time in the pulse detector circuit connected to these outputs.

Sleep Mode

When CS is high, initially all circuitry is shut down so that power dissipation is reduced to 3 mW in the *sleep mode*. Switching the CS line low *wakes up* the chip and the device will enter the read or write mode, depending on the status of the R/W line.

Diode Connected Damping Resistor (patent pending)

The VM7100 has damping resistors isolated by Schottky diodes as an option. The diodes effectively remove the resistor from the circuit during the read mode, however during the write mode with the higher level input signal, the resistor provides damping for the write current waveform.

Input Structure:

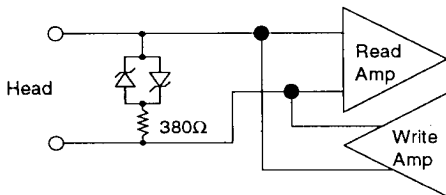

Table 1: Head Select

HS2	HS1	HS0	HEAD
0	0	0	0
0	0	1	1
0	1	0	2
0	1	1	3
1	0	0	4
1	0	1	5
1	1	0	6
1	1	1	7

Table 2: Mode Select

\overline{CS}	R/\overline{W}	MODE
0	0	Write/Awake
0	1	Read/Awake
1	X	Sleep

PIN DESCRIPTIONS

NAME	I/O	DESCRIPTION
HS0-HS2	I*	Head Select: selects one of up to 8 heads
H0X-H7X H0Y-H7Y	I/O	X, Y Head terminals
WDI	I*	Write Data Input: TTL input signal, negative transition toggles direction of head current
\overline{CS}	I	Chip select: high level signal puts chip in sleep mode, low level wakes chip up
R/\overline{W}	I*	Read/Write select: High level selects read mode, low-level selects write mode
WUS	O*	Write unsafe: Open collector output: high level indicates writes unsafe condition
WC		Write current adjust: A resistor adjusts level of write current
RDX-RDY	O*	Read data output: differential output data
VCC		+5 volt supply**
GND		Ground

* May be wire-OR'ed for multi-chip usage.

** Although both VCC connections are recommended, only one connection is required as both are connected internally.

DC CHARACTERISTICS Recommended operating conditions apply unless otherwise specified.

PARAMETER	SYM	CONDITIONS	MIN	TYP (Note 1)	MAX	UNITS
Supply Current	I _{CC}	Read Mode		34 + .05 I _W	51 + .05 I _W	mA
		Write Mode		44 + 1.05 I _W	52 + 1.05 I _W	
		Idle Mode		0.6	3	
Power Dissipation	PD	Read Mode, I _W = 20mA		165	286	mW
		Write Mode, I _W = 20mA		320	402	
		Idle Mode		3	17	
Input High Voltage	V _{IH}		2		V _{CC} +0.3	V
Input Low Voltage	V _{IL}		-0.3		0.8	V
Input High Current	I _{IH}	V _{IH} = 2.7V			80	μA
Input Low Current	I _{IL}	V _{IL} = 0.4V	-160			μA
WUS Output Low Voltage	V _{OL}	I _{OL} = 4.0mA		0.35	0.5	V
WUS Output High Current	I _{OH}	V _{OH} = 5.0V		13	100	μA
VCC Value for Write Current Turn Off		I _H < 0.2mA	3.7	4.0	4.3	V

Note 1: Typical values are given at V_{CC} = 5V and T_A = 25°C.

Table 3: Input Noise and Differential Input Capacitance Options Available

Input Noise			Input Capacitance			Option Designator
TYP	MAX	UNIT	TYP	MAX	UNIT	
0.50	0.70	nV/√Hz	32	45	pF	None / Standard
0.60	0.75		16	23		I
0.70	0.85		9	16		C

Table 4: Differential Read Voltage Gain

MIN	TYP	MAX	UNIT	Gain Option Designator
84	100	116	V/V	10
125	150	175		15
167	200	233		20
210	250	290		25
250	300	350		30

TWO/THREE TERMINAL & SERVO PREAMPLIFIERS

READ CHARACTERISTICS Recommended operating conditions apply unless otherwise specified; C_L (RDX, RDY) < 20pF, R_L (RDX, RDY) = 1k Ω .

PARAMETER	SYM	CONDITIONS	MIN	TYP (Note 1)	MAX	UNITS
Differential Voltage Gain	A _V	V _{IN} = 1mVrms, 1MHz; see Table 4	—	—	—	V/V
Bandwidth	BW	-1dB Z _s < 5 Ω , V _{IN} = 1mVp-p, gain = 150	40	55		MHz
		-3dB Z _s < 5 Ω , V _{IN} = 1mVp-p, gain = 150	65	85		
Input Noise Voltage	e _{in}	BW = 17MHz, L _H = 0, R _H = 0, see Table 3		0.5	0.7	nV/ $\sqrt{\text{Hz}}$
Differential Input Capacitance	C _{IN}	V _{IN} = 1mVp-p, f = 5MHz, see Table 3		33	45	pF
Low Input Capacitance (optional)	C _{IN}	V _{IN} = 1mVp-p, f = 5MHz, see Table 3		9	16	pF
Differential Input Resistance	R _{IN}	V _{IN} = 1mVp-p, f = 5MHz	280	1000		Ω
Dynamic Range	DR	AC input where A _v is 90% of gain at 0.2mVrms input	2	5		mVrms
Common Mode Rejection Ratio	CMRR	V _{IN} = 100mVp-p @ 5MHz	50	70		dB
Power Supply Rejection Ratio	PSRR	100mVp-p @ 5MHz on V _{CC}	45	66		dB
Channel Separation	CS	Unselected channel driven with 20mVp-p @ 5MHz	40	45		dB
Output Offset Voltage	V _{OS}		-300	2	+300	mV
RDX,RDY Common Mode Output Voltage	V _{OCM}	Read Mode		V _{CC} -2.7		VDC
Read to Write Common Mode Output Voltage Difference	Δ V _{OCM}		-350	-45	350	mV
Single-Ended Output Resistance	R _{SEO}			22	35	Ω
Output Current	I _O	AC Coupled Load, RDX to RDY	\pm 1.5			mA

Note 1: Typical values are given at V_{CC} = 5V and T_A = 25°C.

VM7100

WRITE CHARACTERISTICS Recommended operating conditions apply unless otherwise specified; $L_H = 1\mu H$, $R_H = 30\Omega$, $I_W = 20mA$, $f_{DATA} = 5MHz$.

PARAMETER	SYM	CONDITIONS	MIN	TYP <small>(Note 1)</small>	MAX	UNITS
WC Pin Voltage	VWC			2.5		V
I_{WC} to Head Current Gain	A _I			20		mA/mA
Write Current Constant	K _W	$K_W = (V_{WC})(A_I)$	46	50	54	V
Write Current Range	I _W	$1.258K < R_{WC} < 60k\Omega$	1		40	mA
Write Current Tolerance	ΔI_W	$I_W = 10 - 40mA$	-8	-1	+8	%
Differential Head Voltage Swing	V _{DH}		4.5	5.4		Vp-p
WDI Transition Frequency for Safe Condition	f _{DATA}	WUS = low	1			MHz
Differential Output Capacitance	C _O				15	pF
Differential Output Resistance	R _O		3200			Ω
Unselected Head Transient Current	I _{UH}	$I_W = 15mA$		0.15	1	mA(pk)
RDX, RDY Common Mode Output Voltage	V _{CM}			V _{CC} -2.7		V

Note 1: Typical values are given at $V_{CC} = 5V$ and $T_A = 25^\circ C$.

TWO/THREE TERMINAL & SERVO PREAMPLIFIERS

SWITCHING CHARACTERISTICS Recommended operating conditions apply unless otherwise specified; $I_W = 20\text{mA}$, $f_{\text{DATA}} = 5\text{MHz}$, $L_H = 1\mu\text{H}$, $R_H = 30\Omega$, C_L (RDX, RDY) $\leq 20\text{pF}$ (see Figure 1).

PARAMETER	SYM	CONDITIONS	MIN	TYP (Note 1)	MAX	UNITS
$\overline{\text{R/W}}$ Read to Write Delay	t_{RW}	$\overline{\text{R/W}}$ to 90% I_W		0.06	1.0	μs
$\overline{\text{R/W}}$ Write to Read Delay	t_{WR}	$\overline{\text{R/W}}$ to 90% of 100mV, 10MHz read signal envelope		0.15	1.0	μs
$\overline{\text{CS}}$ Unselect to Select Delay	t_{IR}	$\overline{\text{CS}}$ to 90% I_W or 90% of 100mV, 10MHz read signal envelope		0.23	0.6	μs
$\overline{\text{CS}}$ Select to Unselect Delay	t_{RI}	$\overline{\text{CS}}$ to 10% of I_W		0.02	0.6	μs
HS0, 1, any Head Delay	t_{HS}	HS0, 1 to 90% of 100mV, 10MHz read signal envelope		0.23	0.6	μs
WUS Safe to Unsafe Delay	t_{D1}		0.6	2.1	3.6	μs
WUS Unsafe to Safe Delay	t_{D2}				1.0	μs
Head Current Propagation Delay (TD3)	t_{D3}	$L_H = 0$, $R_H = 0$, from 50% points		12	30	ns
Head Current Asymmetry	ASYM	50% duty cycle on WDI, 1ns rise/fall time; $L_H = 0$, $R_H = 0$		0.04	0.5	ns
Head Current Rise/Fall Time	t_r/t_f	10% to 90% points	$L_H = 0$, $R_H = 0$	2	5	ns
			$L_H = 1\mu\text{H}$, $R_H = 30\Omega$	12	16	

Note 1: Typical values are given at $V_{\text{CC}} = 5\text{V}$ and $T_A = 25^\circ\text{C}$.

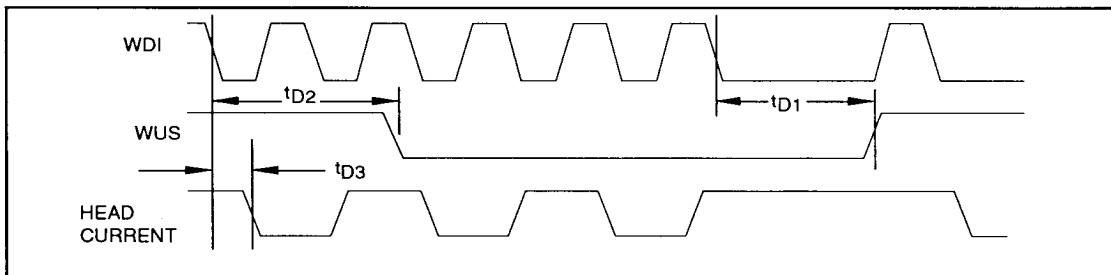

Figure 1: Write Mode Timing Diagram

TWO/THREE TERMINAL
8 SERVO PREAMPLIFIERS