

16-bit Proprietary Microcontroller

CMOS

F²MC-16LX MB90350 Series

MB90F352/S, MB90352/S

■ DESCRIPTION

The MB90350-series with 1 channel FULL-CAN* interface and FLASH ROM is especially designed for automotive and industrial applications. Its main feature is the on-board CAN Interface, which conform to V2.0 Part A and Part B, while supporting a very flexible message buffer scheme and so offering more functions than a normal full CAN approach. With the new 0.35 μm CMOS technology, Fujitsu now offers on-chip FLASH-ROM program memory up to 128 Kbytes. An internal voltage booster removes the necessity for a second programming voltage.

An on board voltage regulator provides 3 V to the internal MCU core. This creates a major advantage in terms of EMI and power consumption.

The internal PLL clock frequency multiplier provides an internal 42 ns instruction cycle time from an external 4 MHz clock.

The unit features a 4 channel Output Compare Unit and 6 channel Input Capture Unit with 2 separate 16-bit free running timers. 2 channels UART constitute additional functionality for communication purposes.

* : Controller Area Network (CAN) - License of Robert Bosch GmbH

Note : F²MC stands for FUJITSU Flexible Microcontroller, a registered trademark of FUJITSU LIMITED.

■ PACKAGE

64-pin Plastic LQFP

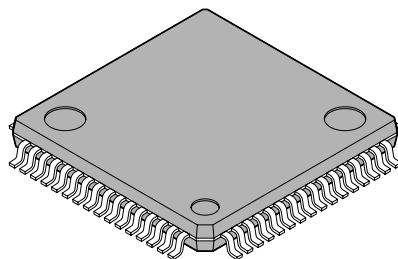

(FPT-64P-M09)

MB90350 Series

■ FEATURES

● Clock

- Built-in PLL clock frequency multiplication circuit
- Selection of machine clocks (PLL clocks) is allowed among frequency division by two on oscillation clock, and multiplication of 1 to 6 times of oscillation clock (for 4 MHz oscillation clock, 4 MHz to 24 MHz).
- Operation by sub-clock (up to 50 kHz : 100 kHz oscillation clock divided by two) is allowed. (devices without S-suffix only)
- Minimum execution time of instruction : 42 ns (when operating with 4-MHz oscillation clock, and 6-time multiplied PLL clock).
- Built-in clock modulation circuit

● 16 Mbyte CPU memory space

- 24-bit internal addressing

● External Bus Interface

- 4 MByte external memory space

● Instruction system best suited to controller

- Wide choice of data types (bit, byte, word, and long word)
- Wide choice of addressing modes (23 types)
- Enhanced multiply-divide instructions and RETI instructions
- Enhanced high-precision computing with 32-bit accumulator

● Instruction system compatible with high-level language (C language) and multitask

- Employing system stack pointer
- Enhanced various pointer indirect instructions
- Barrel shift instructions

● Increased processing speed

- 4-byte instruction queue

● Powerful interrupt function

- Powerful 8-level, 34-condition interrupt feature
- Up to 8 channels external interrupts are supported

● Automatic data transfer function independent of CPU

- Extended intelligent I/O service function (EI²OS) : up to 16 channels
- DMA : up to 16 channels

● Low power consumption (standby) mode

- Sleep mode (a mode that halts CPU operating clock)
- Main timer mode (a timebase timer mode switched from the main clock mode)
- PLL timer mode (a timebase timer mode switched from the PLL clock mode)
- Watch mode (a mode that operates sub clock and clock timer only)
- Stop mode (a mode that stops oscillation clock and sub clock)
- CPU blocking operation mode

● Process

- CMOS technology

● I/O port

- General-purpose input/output port (CMOS output)
 - 49 ports (devices without S-suffix)
 - 51 ports (devices with S-suffix)

(Continued)

(Continued)

- **Timer**

- Time-base timer, clock timer, watchdog timer : 1 channel
- 8/16-bit PPG timer : 8-bit × 10 channels, or 16-bit × 6 channels
- 16-bit reload timer : 4 channels
- 16-bit input/output timer
 - 16-bit free run timer : 2 channels (FRT0 : ICU0/1, FRT1 : ICU 4/5/6/7, OCU 4/5/6/7)
 - 16-bit input capture: (ICU) : 6 channels
 - 16-bit output compare : (OCU) : 4 channels

- **Full-CAN interface : 1 channel**

- Compliant with Ver2.0A and Ver2.0B CAN specifications
- Flexible message buffering (mailbox and FIFO buffering can be mixed)
- CAN wake-up function

- **UART (LIN/SCI) : 2 channels**

- Equipped with full-duplex double buffer
- Clock-asynchronous or clock-synchronous serial transmission is available

- **I²C interface* : 1 channel**

- Up to 400 Kbit/s transfer rate

- **DTP/External interrupt : 8 channels, CAN wakeup : 1 channel**

- Module for activation of extended intelligent I/O service (EI²OS), DMA, and generation of external interrupt.

- **Delay interrupt generator module**

- Generates interrupt request for task switching.

- **8/10-bit A/D converter : 15 channels**

- Resolution is selectable between 8-bit and 10-bit.
- Activation by external trigger input is allowed.
- Conversion time : 3 μs (at 24-MHz machine clock, including sampling time)

- **Program patch function**

- Address matching detection for 6 address pointers.

- **Internal voltage regulator**

- Supports 3 V MCU core, offering low EMI and low power consumption figures

- **Programmable input levels**

- Automotive/CMOS-Schmitt (initial level is Automotive in Single chip mode)
- TTL level (initial level for External bus mode)

- **Flash security function**

- Protects the content of Flash (Flash device only)

* : I²C license :

Purchase of Fujitsu I²C components conveys a license under the Philips I²C Patent Rights to use, these components in an I²C system provided that the system conforms to the I²C Standard Specification as defined by Philips.

MB90350 Series

■ PRODUCT LINEUP

Part Number	MB90F352/S, MB90352/S*1	MB90V340A-101/102
Parameter		
CPU	F ² MC-16LX CPU	
System clock	On-chip PLL clock multiplier (×1, ×2, ×3, ×4, ×6, 1/2 when PLL stops) Minimum instruction execution time : 42 ns (4 MHz osc. PLL × 6)	
ROM	Boot-block, Flash memory 128 Kbytes	External
RAM	4 Kbytes	30 Kbytes
Emulator-specific power supply*2	—	Yes
Technology	0.35 μm CMOS with regulator for internal power supply + Flash memory charge pump for programming voltage	0.35 μm CMOS with regulator for internal power supply
Operating voltage range	3.5 V - 5.5 V : at normal operating (not using A/D converter) 4.0 V - 5.5 V : at using A/D converter/Flash programming 4.5 V - 5.5 V : at using external bus	5 V ± 10%
Temperature range	−40 °C to +105 °C (125 °C up to 16 MHz machine clock)	—
Package	LQFP-64	PGA-299
UART	2 channels	3 channels
	Wide range of baud rate settings using a dedicated reload timer Special synchronous options for adapting to different synchronous serial protocols LIN functionality working either as master or slave LIN device	
I ² C (400 kbit/s)	1 channel	1 channel
A/D Converter	15 channels	
	10-bit or 8-bit resolution Conversion time : Min 3 μs include sample time (per one channel)	
16-bit Reload Timer (4 channels)	Operation clock frequency : $f_{sys}/2^1$, $f_{sys}/2^3$, $f_{sys}/2^5$ (f_{sys} = Machine clock frequency) Supports External Event Count function	
16-bit I/O Timer (2 channels)	Signals an interrupt when overflowing Supports Timer Clear when a match with Output Compare (Channel 0, 4) Operation clock freq. : f_{sys} , $f_{sys}/2^1$, $f_{sys}/2^2$, $f_{sys}/2^3$, $f_{sys}/2^4$, $f_{sys}/2^5$, $f_{sys}/2^6$, $f_{sys}/2^7$ (f_{sys} = Machine clock freq.) I/O Timer 0 (clock input FRCK0) corresponds to ICU 0/1 I/O Timer 1 (clock input FRCK1) corresponds to ICU 4/5/6/7, OCU 4/5/6/7	
16-bit Output Compare (4 channels)	Signals an interrupt when 16-bit I/O Timer match output compare registers. A pair of compare registers can be used to generate an output signal.	
16-bit Input Capture (6 channels)	Rising edge, falling edge or rising & falling edge sensitive Signals an interrupt upon external event	

(Continued)

MB90350 Series

Part Number	MB90F352/S, MB90352/S*1	MB90V340A-101/102
Parameter		
8/16-bit Programmable Pulse Generator 6 channels (16-bit) / 10 channels (8-bit)	Supports 8-bit and 16-bit operation modes 8-bit reload counters × 12 8-bit reload registers for L pulse width × 12 8-bit reload registers for H pulse width × 12 A pair of 8-bit reload counters can be configured as one 16-bit reload counter or as 8-bit prescaler + 8-bit reload counter Operation clock freq. : fsys, fsys/2 ¹ , fsys/2 ² , fsys/2 ³ , fsys/2 ⁴ or 128 μs@fosc = 4 MHz (fsys = Machine clock frequency, fosc = Oscillation clock frequency)	
CAN Interface	1 channel	2 channels
	Conforms to CAN Specification Version 2.0 Part A and B Automatic re-transmission in case of error Automatic transmission responding to Remote Frame Prioritized 16 message buffers for data and ID's Supports multiple messages Flexible configuration of acceptance filtering : Full bit compare/Full bit mask/Two partial bit masks Supports up to 1 Mbps	
External Interrupt (8 channels)	Can be used rising edge, falling edge, starting up by H/L level input, external interrupt, extended intelligent I/O services (EI ² OS) and DMA	
D/A converter	—	1 channel
Subclock (up to 100 kHz)	devices with 'S'-suffix and MB90V340A-102 : without subclock devices without 'S'-suffix and MB90V340A-101 : with subclock	
I/O Ports	Virtually all external pins can be used as general purpose I/O port All push-pull outputs Bit-wise settable as input/output or peripheral signal Settable as CMOS schmitt trigger/ automotive inputs (default) TTL input level settable for external bus (30 terminals only for external bus)	
Flash Memory	Supports automatic programming, Embedded Algorithm ^{TM*3} Write/Erase/Erase-Suspend/Resume commands A flag indicating completion of the algorithm Number of erase cycles : 10,000 times Data retention time : 10 years Boot block configuration Erase can be performed on each block Block protection with external programming voltage Flash Security Feature for protecting the content of the Flash	—

*1 : The devices are under development.

*2 : It is setting of Jumper switch (TOOL V_{CC}) when Emulator (MB2147-01) is used.
Please refer to the Emulator hardware manual about details.

*3 : Embedded Algorithm is a trade mark of Advanced Micro Devices Inc.

MB90350 Series

PIN ASSIGNMENTS

- MB90F352/S, MB90352/S

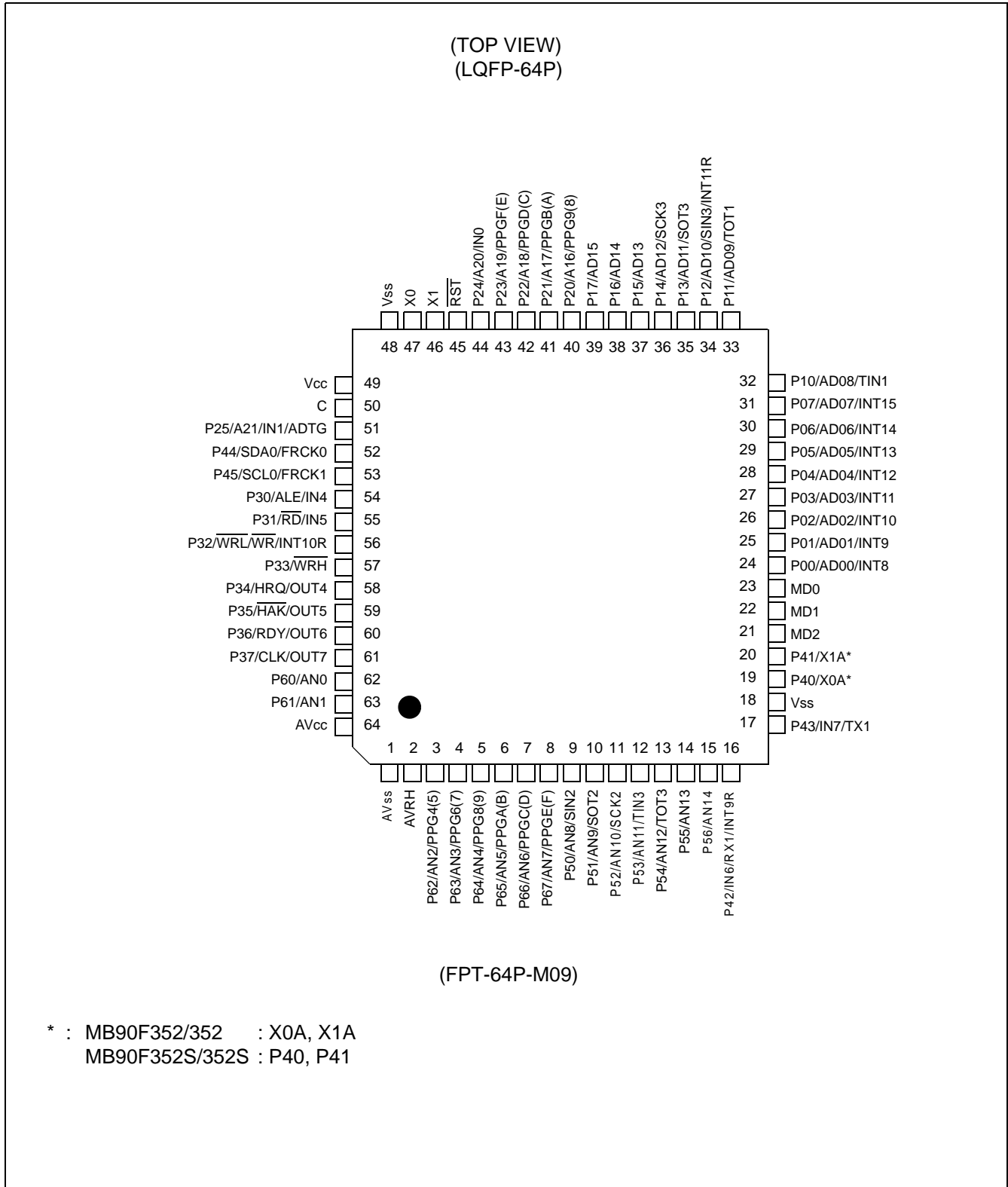

■ PIN DESCRIPTION

Pin No.	Pin name	Circuit type	Function
LQFP64*			
46	X1	A	Oscillation output pin.
47	X0		Oscillation input pin.
45	$\overline{\text{RST}}$	E	Reset input pin.
3 to 8	P62 to P67	I	General purpose I/O ports.
	AN2 to AN7		Analog input pins for A/D converter.
	PPG4, 6, 8, A, C, E		Output pins for PPGs.
9	P50	O	General purpose I/O port.
	AN8		Analog input pin for A/D converter.
	SIN2		Serial data input pin for UART2.
10	P51	I	General purpose I/O port.
	AN9		Analog input pin for A/D converter.
	SOT2		Serial data output pin for UART2.
11	P52	I	General purpose I/O port.
	AN10		Analog input pin for A/D converter.
	SCK2		Serial data output pin for UART2.
12	P53	I	General purpose I/O port.
	AN11		Analog input pin for A/D converter.
	TIN3		Event input pin for reload timer3.
13	P54	I	General purpose I/O port.
	AN12		Analog input pin for A/D converter.
	TOT3		Output pin for reload timer3.
14, 15	P55, P56	I	General purpose I/O ports.
	AN13, AN14		Analog input pins for A/D converter.
16	P42	F	General purpose I/O port.
	IN6		Data sample input pin for input capture ICU6.
	RX1		RX input pin for CAN1.
	INT9R		External interrupt request input pin for INT9.
17	P43	F	General purpose I/O port.
	IN7		Data sample input pin for input capture ICU7.
	TX1		TX output pin for CAN1.
19, 20	P40, P41	F	General purpose I/O ports (devices with S-suffix and MB90V340A-101) .
	X0A, X1A	B	Oscillation input pins for sub clock (devices without S-suffix and MB90V340A-102) .

(Continued)

MB90350 Series

Pin No.	Pin name	Circuit type	Function
LQFP64*			
24 to 31	P00 to P07	G	General purpose I/O ports. The register can be set to select whether to use a pull-up resistor. This function is enabled in single-chip mode.
	AD00 to AD07		Input/output pins of external address data bus lower 8 bit. This function is enabled when the external bus is enabled.
	INT8 to INT15		External interrupt request input pins for INT8 to INT15.
32	P10	G	General purpose I/O port. The register can be set to select whether to use a pull-up resistor. This function is enabled in single-chip mode.
	AD08		Input/output pin for external bus address data bus bit 8. This function is enabled when external bus is enabled.
	TIN1		Event input pin for reload timer1.
33	P11	G	General purpose I/O. The register can be set to select whether to use a pull-up resistor. This function is enabled in single-chip mode.
	AD09		Input/output pin for external bus address data bus bit 9. This function is enabled when external bus is enabled.
	TOT1		Output pin for reload timer1.
34	P12	N	General purpose I/O port. The register can be set to select whether to use a pull-up resistor. This function is enabled in single-chip mode.
	AD10		Input/output pin for external bus address data bus bit 10. This function is enabled when external bus is enabled.
	SIN3		Serial data input pin for UART3.
	INT11R		External interrupt request input pin for INT11
35	P13	G	General purpose I/O port. The register can be set to select whether to use a pull-up resistor. This function is enabled in single-chip mode.
	AD11		Input/output pin for external bus address data bus bit 11. This function is enabled when external bus is enabled.
	SOT3		Serial data output pin for UART3.
36	P14	G	General purpose I/O port. The register can be set to select whether to use a pull-up resistor. This function is enabled in single-chip mode.
	AD12		Input/output pin for external bus address data bus bit 12. This function is enabled when external bus is enabled.
	SCK3		Clock input/output pin for UART3.
37	P15	N	General purpose I/O port. The register can be set to select whether to use a pull-up resistor. This function is enabled in single-chip mode.
	AD13		Input/output pin for external bus address data bus bit 13. This function is enabled when external bus is enabled.
38	P16	G	General purpose I/O port. The register can be set to select whether to use a pull-up resistor. This function is enabled in single-chip mode.
	AD14		Input/output pin for external bus address data bus bit 14. This function is enabled when external bus is enabled.

(Continued)

MB90350 Series

Pin No. LQFP64*	Pin name	Circuit type	Function
39	P17	G	General purpose I/O port. The register can be set to select whether to use a pull-up resistor. This function is enabled in single-chip mode.
	AD15		Input/output pin for external bus address data bus bit 15. This function is enabled when external bus is enabled.
40 to 43	P20 to P23	G	General purpose I/O ports. The register can be set to select whether to use a pull-up resistor. In external bus mode, the pin is enabled as a general-purpose I/O port when the corresponding bit in the external address output control register (HACR) is 1.
	A16 to A19		Output pins for A16 to A19 of the external address bus. When the corresponding bit in the external address output control register (HACR) is 0, the pins are enabled as high address output pins A16 to A19.
	PPG9, PPGB, PPGD, PPGF		Output pins for PPGs.
44	P24	G	General purpose I/O port. The register can be set to select whether to use a pull-up resistor. In external bus mode, the pin is enabled as a general-purpose I/O port when the corresponding bit in the external address output control register (HACR) is 1.
	A20		Output pins for A20 of the external address bus. When the corresponding bit in the external address output control register (HACR) is 0, the pin is enabled as high address output pins A20.
	IN0		Data sample input pin for input capture ICU0.
51	P25	G	General purpose I/O port. The register can be set to select whether to use a pull-up resistor. In external bus mode, the pin is enabled as a general-purpose I/O port when the corresponding bit in the external address output control register (HACR) is 1.
	A21		Output pin for A21 of the external address bus. When the corresponding bit in the external address output control register (HACR) is 0, the pin is enabled as high address output pin A21.
	IN1		Data sample input pin for input capture ICU1.
	ADTG		Trigger input pin for A/D converter.
52	P44	H	General purpose I/O port
	SDA0		Serial data I/O pin for I ² C 0
	FRCK0		Input pin for the 16-bit I/O Timer 0
53	P45	H	General purpose I/O port.
	SCL0		Serial clock I/O pin for I ² C 0
	FRCK1		Input for the 16-bit I/O Timer 1
54	P30	G	General purpose I/O port. The register can be set to select whether to use a pull-up resistor. This function is enabled in single-chip mode.
	ALE		Address latch enable output pin. This function is enabled when external bus is enabled.
	IN4		Data sample input pin for input capture ICU4.

(Continued)

MB90350 Series

Pin No. LQFP64*	Pin name	Circuit type	Function
55	P31	G	General purpose I/O port. The register can be set to select whether to use a pull-up resistor. This function is enabled in single-chip mode.
	\overline{RD}		Read strobe output pin for data bus. This function is enabled when external bus is enabled.
	IN5		Data sample input pin for input capture ICU5.
56	P32	G	General purpose I/O port. The register can be set to select whether to use pull-up resistor. This function is enabled either in single-chip mode or with the $\overline{WR/WRL}$ pin output disabled.
	$\overline{WR/WRL}$		Write strobe output pin for the data bus. This function is enabled when both the external bus and the $\overline{WR/WRL}$ pin output are enabled. \overline{WRL} is used to write-strobe 8 lower bits of the data bus in 16-bit access. \overline{WR} is used to write-strobe 8 bits of the data bus in 8-bit access.
	INT10R		External interrupt request input pin for INT10.
57	P33	G	General purpose I/O port. The register can be set to select whether to use a pull-up resistor. This function is enabled either in single-chip mode or with the \overline{WRH} pin output disabled.
	\overline{WRH}		Write strobe output pin for the 8 higher bits of the data bus. This function is enabled when the external bus is enabled, when the external bus 16-bit mode is selected, and when the \overline{WRH} output pin is enabled.
58	P34	G	General purpose I/O port. The register can be set to select whether to use a pull-up resistor. This function is enabled either in single-chip mode or with the hold function disabled.
	HRQ		Hold request input pin. This function is enabled when both the external bus and the hold function are enabled.
	OUT4		Waveform output pin for output compare OCU4.
59	P35	G	General purpose I/O port. The register can be set to select whether to use a pull-up resistor. This function is enabled either in single-chip mode or with the hold function disabled.
	\overline{HAK}		Hold acknowledge output pin. This function is enabled when both the external bus and the hold function are enabled.
	OUT5		Waveform output pin for output compare OCU5.
60	P36	G	General purpose I/O port. The register can be set to select whether to use a pull-up resistor. This function is enabled either in single-chip mode or with the external ready function disabled.
	RDY		Ready input pin. This function is enabled when both the external bus and the external ready function are enabled.
	OUT6		Waveform output pin for output compare OCU6.
61	P37	G	General purpose I/O port. The register can be set to select whether to use a pull-up resistor. This function is enabled either in single-chip mode or with the CLK output disabled.
	CLK		CLK output pin. This function is enabled when both the external bus and CLK output are enabled.
	OUT7		Waveform output pin for output compare OCU7.

(Continued)

(Continued)

Pin No.	Pin name	Circuit type	Function
LQFP64*			
62, 63	P60, P61	I	General purpose I/O ports.
	AN0, AN1		Analog input pins for A/D converter.
64	AV _{cc}	K	V _{cc} power input pin for analog circuits.
2	AVRH	L	Reference voltage input for the A/D converter. This power supply must be turned on or off while a voltage higher than or equal to AVRH is applied to AV _{cc} .
1	AV _{ss}	K	V _{ss} power input pin for analog circuits.
22, 23	MD1, MD0	C	Input pins for specifying the operating mode.
21	MD2	D	Input pins for specifying the operating mode.
49	V _{cc}	—	Power (3.5 V to 5.5 V) input pin.
18, 48	V _{ss}	—	Power (0 V) input pins.
50	C	K	This is the power supply stabilization capacitor pin. It should be connected to a higher than or equal to 0.1 μF ceramic capacitor.

* : FPT-64P-M09

MB90350 Series

I/O CIRCUIT TYPE

Type	Circuit	Remarks
A		<p>Oscillation circuit</p> <ul style="list-style-type: none"> High-speed oscillation feedback resistor = approx. 1 MΩ
B		<p>Oscillation circuit</p> <ul style="list-style-type: none"> Low-speed oscillation feedback resistor = approx. 10 MΩ
C		<p>Mask ROM device:</p> <ul style="list-style-type: none"> CMOS Hysteresis input pin <p>Flash device:</p> <ul style="list-style-type: none"> CMOS input pin
D		<p>Mask ROM device:</p> <ul style="list-style-type: none"> CMOS Hysteresis input pin Pull-down resistor value: approx. 50 kΩ <p>Flash device:</p> <ul style="list-style-type: none"> CMOS input pin No Pull-down
E		<p>CMOS Hysteresis input pin</p> <ul style="list-style-type: none"> Pull-up resistor value: approx. 50 kΩ

(Continued)

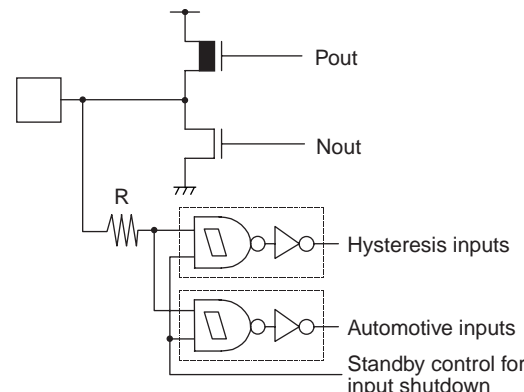
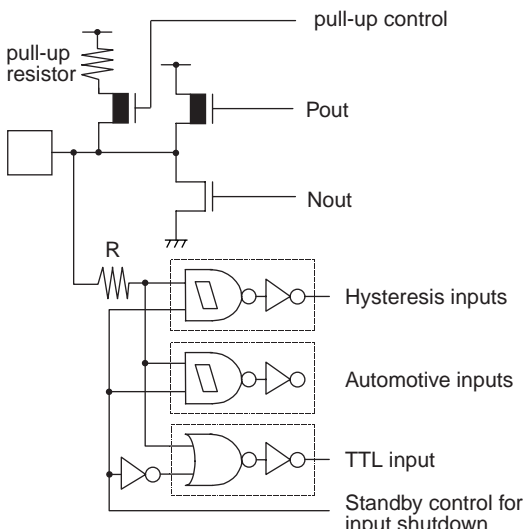
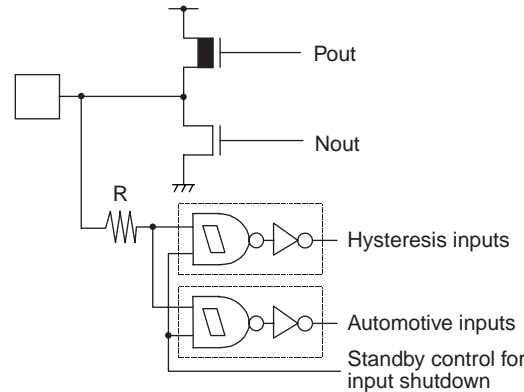
Type	Circuit	Remarks
F	 <p>The diagram shows a CMOS output stage with a PMOS transistor (Pout) and an NMOS transistor (Nout). A pull-up resistor R is connected to the output node. The input node is connected to a square wave source. Below the output stage, there are three input blocks: Hysteresis inputs (two inverters), Automotive inputs (two inverters), and Standby control for input shutdown (one inverter).</p>	<ul style="list-style-type: none"> • CMOS level output ($I_{OL} = 4 \text{ mA}$, $I_{OH} = -4 \text{ mA}$) • CMOS hysteresis inputs (With the standby-time input shutdown function) • Automotive input (With the standby-time input shutdown function)
G	 <p>The diagram shows a CMOS output stage with a PMOS transistor (Pout) and an NMOS transistor (Nout). A pull-up resistor R is connected to the output node. A pull-up control input is connected to the PMOS gate. The input node is connected to a square wave source. Below the output stage, there are four input blocks: Hysteresis inputs (two inverters), Automotive inputs (two inverters), TTL input (one inverter), and Standby control for input shutdown (one inverter).</p>	<ul style="list-style-type: none"> • CMOS level output ($I_{OL} = 4 \text{ mA}$, $I_{OH} = -4 \text{ mA}$) • CMOS hysteresis inputs (With the standby-time input shutdown function) • Automotive input (With the standby-time input shutdown function) • TTL input (With the standby-time input shutdown function) • Programmable pullup resistor: $50 \text{ k}\Omega$ approx.
H	 <p>The diagram shows a CMOS output stage with a PMOS transistor (Pout) and an NMOS transistor (Nout). A pull-up resistor R is connected to the output node. The input node is connected to a square wave source. Below the output stage, there are three input blocks: Hysteresis inputs (two inverters), Automotive inputs (two inverters), and Standby control for input shutdown (one inverter).</p>	<ul style="list-style-type: none"> • CMOS level output ($I_{OL} = 3 \text{ mA}$, $I_{OH} = -3 \text{ mA}$) • CMOS hysteresis inputs (With the standby-time input shutdown function) • Automotive input (With the standby-time input shutdown function)

(Continued)

MB90350 Series

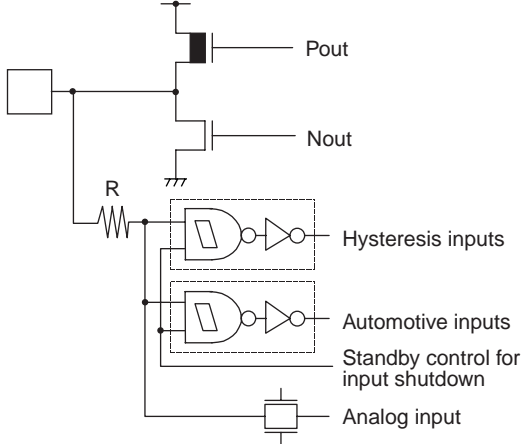
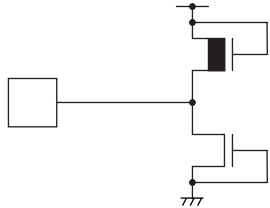
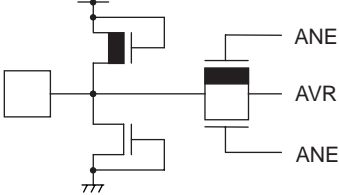
Type	Circuit	Remarks
I		<ul style="list-style-type: none"> • CMOS level output($I_{OL} = 4 \text{ mA}$) • CMOS hysteresis inputs (With the standby-time input shutdown function) • Automotive input (With the standby-time input shutdown function) • A/D analog input
K		<ul style="list-style-type: none"> • Power supply input protection circuit
L		<ul style="list-style-type: none"> • A/D converter reference voltage power supply input pin, with the protection circuit • Flash devices do not have a protection circuit against V_{CC} for pin AVRH

(Continued)

(Continued)

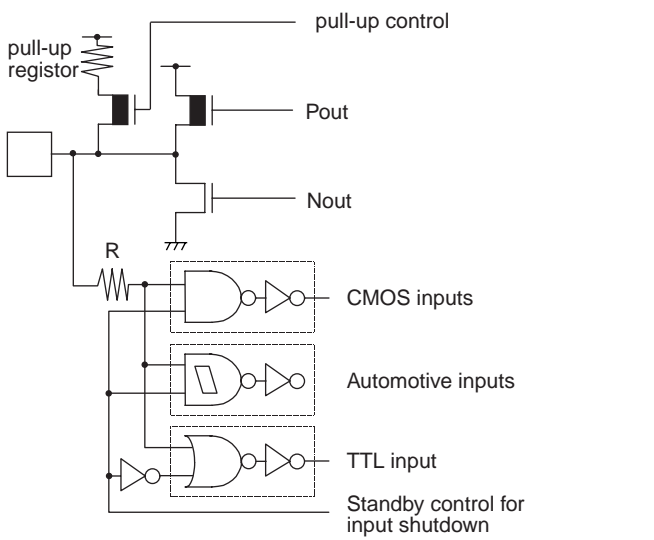
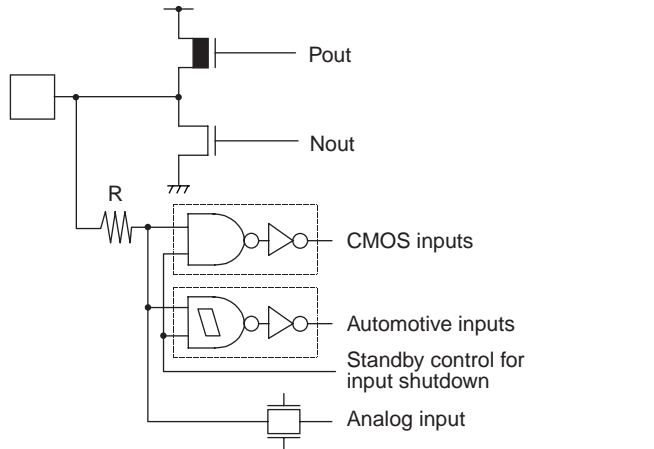
Type	Circuit	Remarks
N	 <p>The diagram for Type N shows a pull-up resistor connected to a pull-up control signal. The output node is connected to Pout and Nout. A resistor R is connected to the input node, which is also connected to CMOS inputs, Automotive inputs, and a TTL input. A Standby control for input shutdown is also shown.</p>	<ul style="list-style-type: none"> • CMOS level output ($I_{OL} = 4 \text{ mA}$, $I_{OH} = -4 \text{ mA}$) • CMOS inputs (With the standby-time input shutdown function) • Automotive input (With the standby-time input shutdown function) • TTL input (With the standby-time input shutdown function) • Programmable pull-up resistor: $50 \text{ k}\Omega$ approx
O	 <p>The diagram for Type O shows a pull-up resistor connected to a pull-up control signal. The output node is connected to Pout and Nout. A resistor R is connected to the input node, which is also connected to CMOS inputs, Automotive inputs, and a Standby control for input shutdown. An Analog input is also shown.</p>	<ul style="list-style-type: none"> • CMOS level output ($I_{OL} = 4 \text{ mA}$, $I_{OH} = -4 \text{ mA}$) • CMOS inputs (With the standby-time input shutdown function) • Automotive input (With the standby-time input shutdown function) • A/D analog input

MB90350 Series

■ HANDLING DEVICES

Special care is required for the following when handling the device :

- Preventing latch-up
- Treatment of unused pins
- Using external clock
- Precautions for when not using a sub clock signal
- Notes on during operation of PLL clock mode
- Power supply pins (V_{CC}/V_{SS})
- Pull-up/down resistors
- Crystal Oscillator Circuit
- Turning-on Sequence of Power Supply to A/D Converter and Analog Inputs
- Connection of Unused Pins of A/D Converter
- Notes on Energization
- Stabilization of power supply voltage
- Initialization
- Port0 to port3 output during Power-on (External-bus mode)
- Notes on using CAN Function
- Flash security Function

1. Preventing latch-up

CMOS IC chips may suffer latch-up under the following conditions :

- A voltage higher than V_{CC} or lower than V_{SS} is applied to an input or output pin.
- A voltage higher than the rated voltage is applied between V_{CC} and V_{SS} .
- The AV_{CC} power supply is applied before the V_{CC} voltage.

Latch-up may increase the power supply current drastically, causing thermal damage to the device.

For the same reason, also be careful not to let the analog power-supply voltage (AV_{CC} , $AVRH$) exceed the digital power-supply voltage.

2. Handling unused pins

Leaving unused input pins open may result in misbehavior or latch up and possible permanent damage of the device. Therefore they must be pulled up or pulled down through resistors. In this case those resistors should be more than 2 k Ω .

Unused bidirectional pins should be set to the output state and can be left open, or the input state with the above described connection.

3. Using external clock

To use external clock, drive the X0 pin and leave X1 pin open.

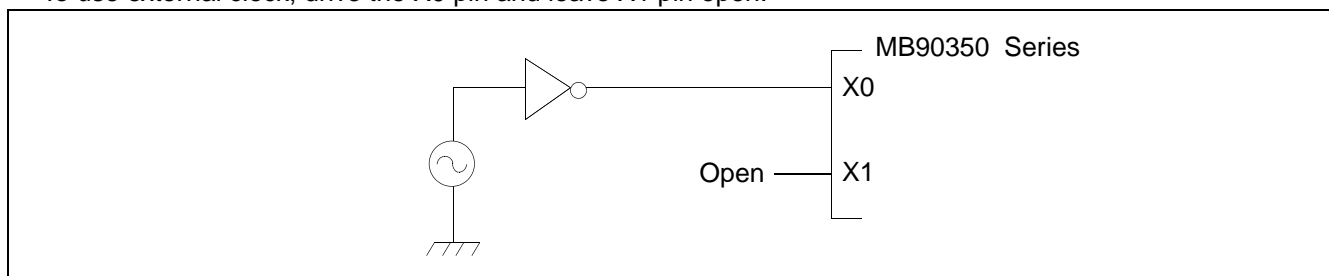

4. Precautions for when not using a sub clock signal

If you do not connect pins X0A and X1A to an oscillator, use pull-down handling on the X0A pin, and leave the X1A pin open.

5. Notes on during operation of PLL clock mode

If the PLL clock mode is selected, the microcontroller attempt to be working with the self-oscillating circuit even when there is no external oscillator or external clock input is stopped. Performance of this operation, however, cannot be guaranteed.

6. Power supply pins (V_{CC}/V_{SS})

- If there are multiple V_{CC} and V_{SS} pins, from the point of view of device design, pins to be of the same potential are connected inside of the device to prevent such malfunctioning as latch up.
To reduce unnecessary radiation, prevent malfunctioning of the strobe signal due to the rise of ground level, and observe the standard for total output current, be sure to connect the V_{CC} and V_{SS} pins to the power supply and ground externally.
- Connect V_{CC} and V_{SS} to the device from the current supply source at a low impedance.
- As a measure against power supply noise, connect a capacitor of about 0.1 μF as a bypass capacitor between V_{CC} and V_{SS} in the vicinity of V_{CC} and V_{SS} pins of the device

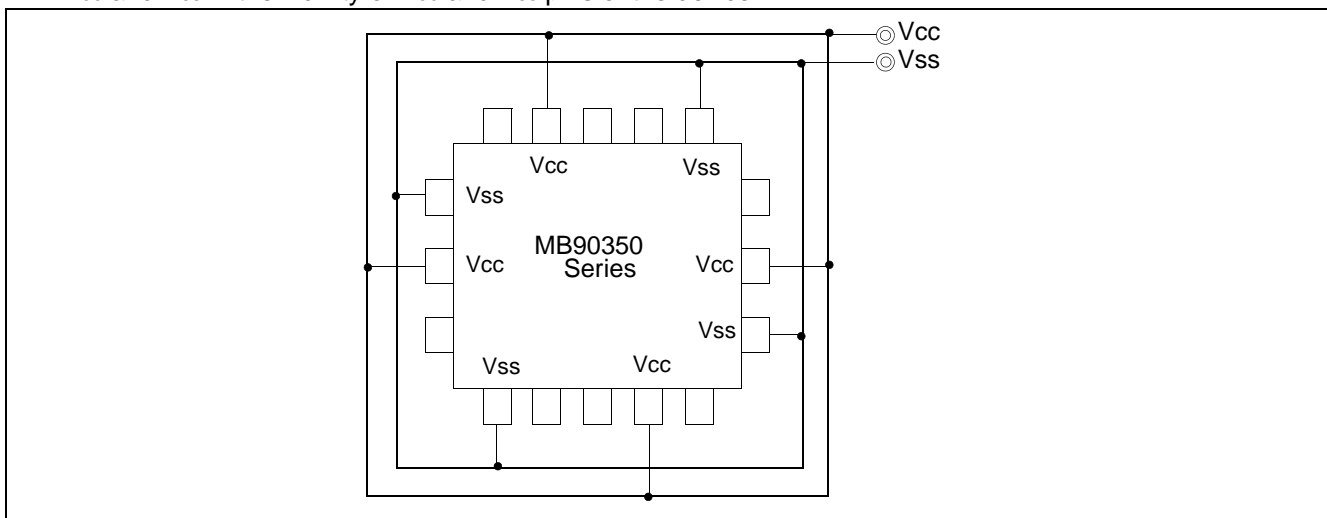

7. Pull-up/down resistors

The MB90350 Series does not support internal pull-up/down resistors (Port 0 to Port 3: built-in pull-up resistors). Use external components where needed.

8. Crystal Oscillator Circuit

Noises around X0 or X1 pins may be possible causes of abnormal operations. Make sure to provide bypass capacitors via shortest distance from X0, X1 pins, crystal oscillator (or ceramic resonator) and ground lines, and make sure, to the utmost effort, that lines of oscillation circuit do not cross the lines of other circuits.

It is highly recommended to provide a printed circuit board art work surrounding X0 and X1 pins with a ground area for stabilizing the operation.

9. Turning-on Sequence of Power Supply to A/D Converter and Analog Inputs

Make sure to turn on the A/D converter power supply (AV_{CC} , AV_{RH}) and analog inputs (AN0 to AN14) after turning-on the digital power supply (V_{CC}).

Turn-off the digital power after turning off the A/D converter supply and analog inputs. In this case, make sure that the voltage does not exceed AV_{RH} or AV_{CC} (turning on/off the analog and digital power supplies simultaneously is acceptable).

10. Connection of Unused Pins of A/D Converter if A/D Converter is used

Connect unused pins of A/D converter to $AV_{CC} = V_{CC}$, $AV_{SS} = AV_{RH} = V_{SS}$.

MB90350 Series

11. Notes on Energization

To prevent the internal regulator circuit from malfunctioning, set the voltage rise time during energization at 50 or more μs (0.2 V to 2.7 V)

12. Stabilization of power supply voltage

A sudden change in the supply voltage may cause the device to malfunction even within the specified V_{CC} supply voltage operating range. Therefore, the V_{CC} supply voltage should be stabilized.

For reference, the supply voltage should be controlled so that V_{CC} ripple variations (peak-to-peak value) at commercial frequencies (50 Hz to 60 Hz) fall below 10% of the standard V_{CC} supply voltage and the coefficient of fluctuation does not exceed 0.1 V/ms at instantaneous power switching.

13. Initialization

In the device, there are internal registers which are initialized only by a power-on reset. To initialize these registers, turn on the power again.

14. Port 0 to port 3 output during Power-on (External-bus mode)

As shown below, when power is turned on in External-Bus mode, there is a possibility that output signal of Port 0 to Port 3 might be unstable.

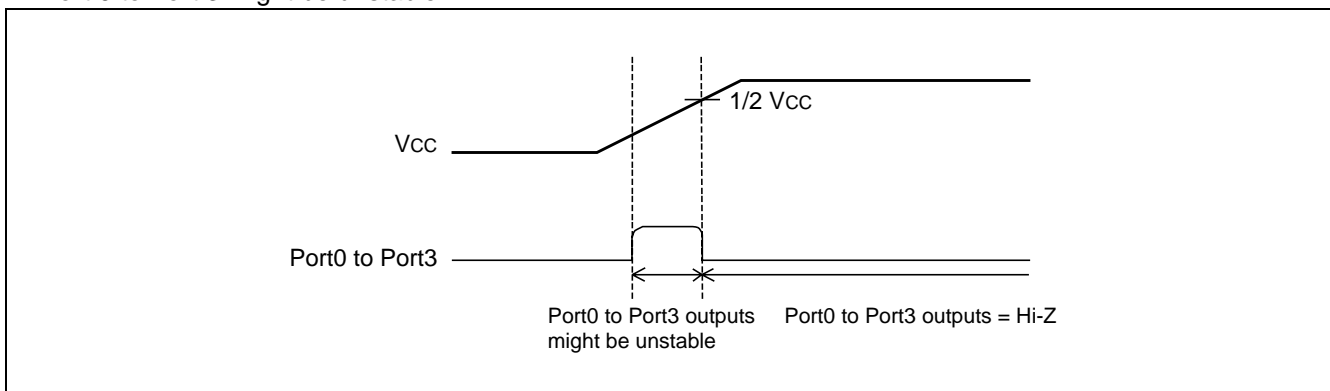

15. Notes on using CAN Function

To use CAN function, please set '1' to DIRECT bit of CAN Direct Mode Register (CDMR).
If DIRECT bit is set to '0' (initial value), wait states will be performed when accessing CAN registers.
Please refer to Hardware Manual of MB90350 series for detail of CAN Direct Mode Register.

16. Flash security Function

The security byte is located in the area of the flash memory.
If protection code 01_H is written in the security bit, the flash memory is in the protected state by security.
Therefore please do not write 01_H in this address if you do not use the security function.
Please refer to following table for the address of the security bit.

	Flash memory size	Address for security bit
MB90F352	Embedded 1 Mbit Flash Memory	FE0001 _H

■ BLOCK DIAGRAMS

• MB90V340A-101/102

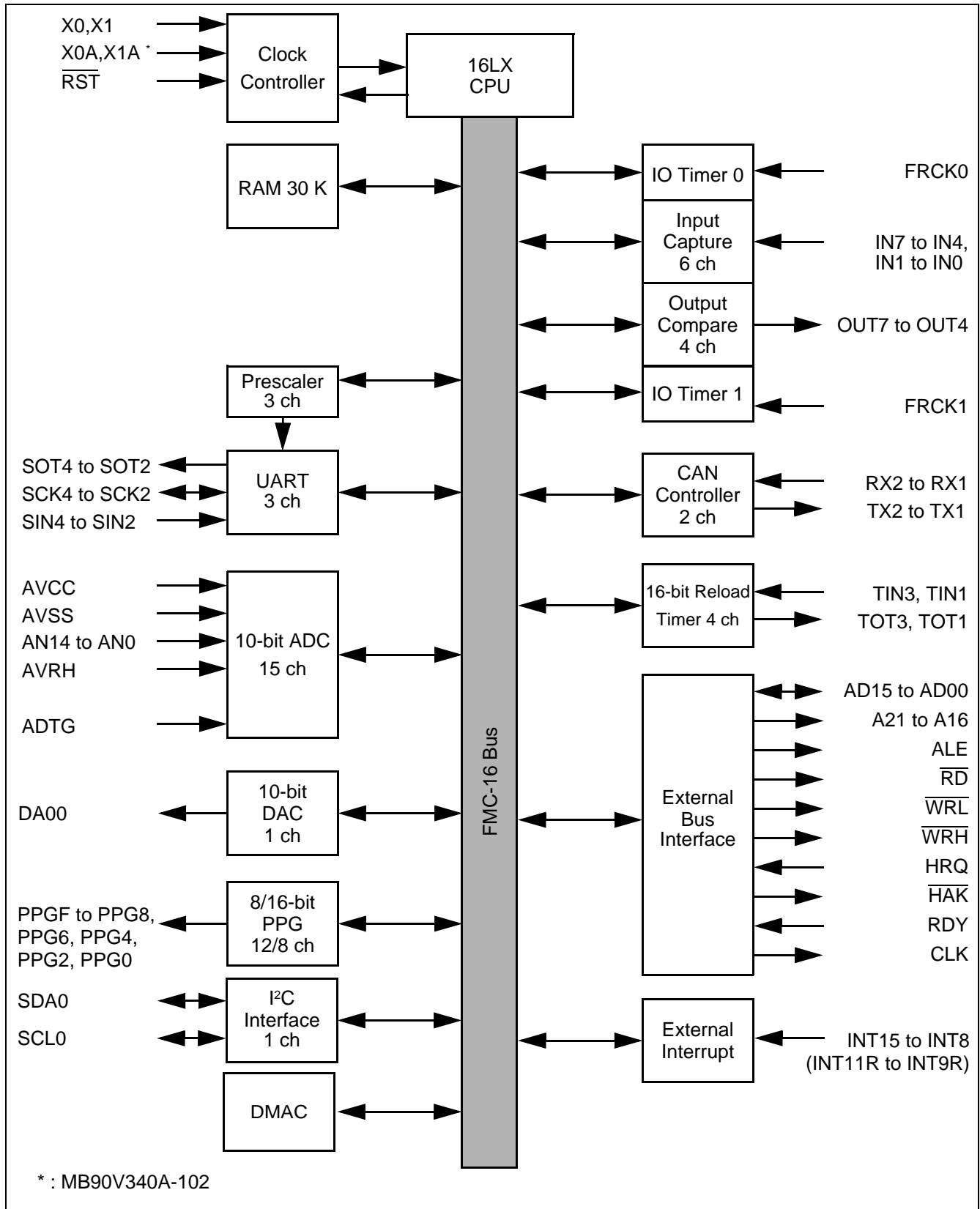

MB90350 Series

• MB90F352/S, MB90352/S

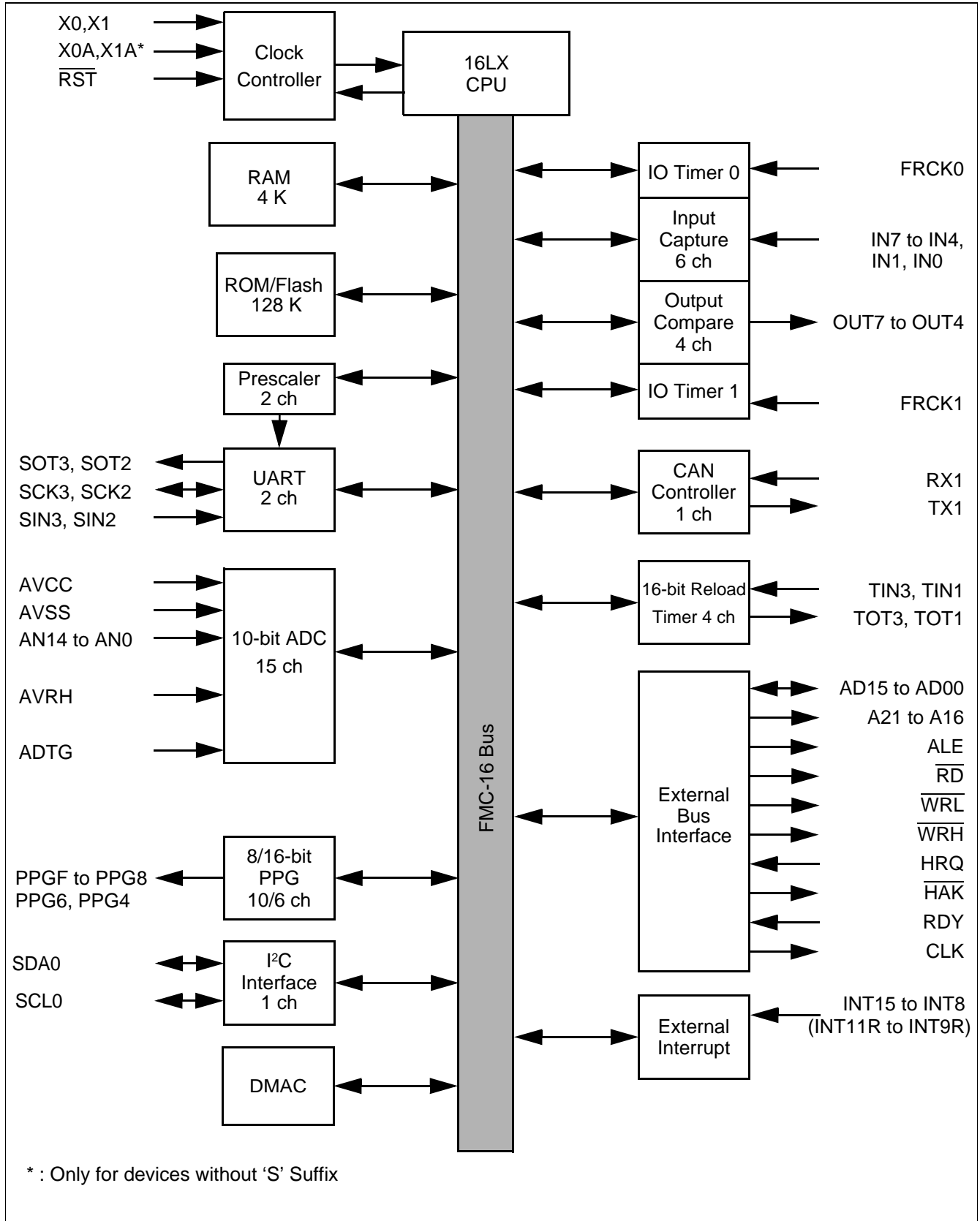

MEMORY MAP

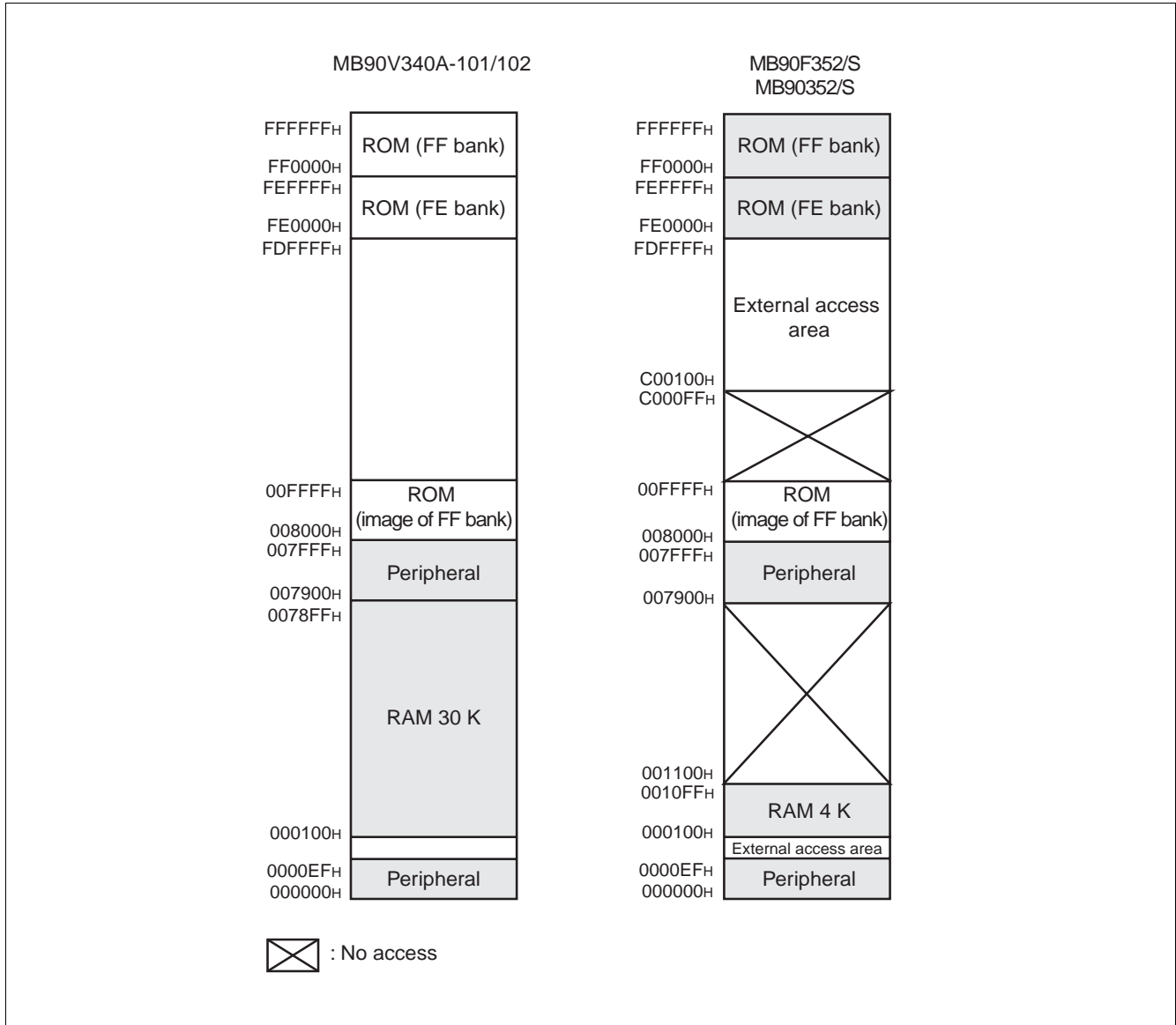

Note : The high-order portion of bank 00 gives the image of the FF bank ROM to make the small model of the C compiler effective. Since the low-order 16 bits are the same, the table in ROM can be referenced without using the far specification in the pointer declaration.

For example, an attempt to access 00C000H accesses the value at FFC000H in ROM.

The ROM area in bank FF exceeds 32 Kbytes, and its entire image cannot be shown in bank 00.

The image between FF8000H and FFFFFFFH is visible in bank 00, while the image between FF0000H and FF7FFFH is visible only in bank FF.

MB90350 Series

■ I/O MAP

Address	Register	Abbreviation	Access	Resource name	Initial value
00 _H	Port 0 Data Register	PDR0	R/W	Port 0	XXXXXXXX
01 _H	Port 1 Data Register	PDR1	R/W	Port 1	XXXXXXXX
02 _H	Port 2 Data Register	PDR2	R/W	Port 2	XXXXXXXX
03 _H	Port 3 Data Register	PDR3	R/W	Port 3	XXXXXXXX
04 _H	Port 4 Data Register	PDR4	R/W	Port 4	XXXXXXXX
05 _H	Port 5 Data Register	PDR5	R/W	Port 5	XXXXXXXX
06 _H	Port 6 Data Register	PDR6	R/W	Port 6	XXXXXXXX
07 _H to 0A _H	Reserved				
0B _H	Analog Input Enable Register 5	ADER5	R/W	Port 5, A/D	11111111
0C _H	Analog Input Enable Register 6	ADER6	R/W	Port 6, A/D	11111111
0D _H	Reserved				
0E _H	Input Level Select Register 0	ILSR0	R/W	Ports	00000000
0F _H	Input Level Select Register 1	ILSR1	R/W	Ports	00000000
10 _H	Port 0 Direction Register	DDR0	R/W	Port 0	00000000
11 _H	Port 1 Direction Register	DDR1	R/W	Port 1	00000000
12 _H	Port 2 Direction Register	DDR2	R/W	Port 2	XX000000
13 _H	Port 3 Direction Register	DDR3	R/W	Port 3	00000000
14 _H	Port 4 Direction Register	DDR4	R/W	Port 4	XX000000
15 _H	Port 5 Direction Register	DDR5	R/W	Port 5	XX000000
16 _H	Port 6 Direction Register	DDR6	R/W	Port 6	00000000
17 _H to 19 _H	Reserved				
1A _H	SIN input Level Setting Register	DDRA	W	UART2, UART3	X00XXXXX
1B _H	Reserved				
1C _H	Port 0 Pull-up Control Register	PUCR0	R/W	Port 0	00000000
1D _H	Port 1 Pull-up Control Register	PUCR1	R/W	Port 1	00000000
1E _H	Port 2 Pull-up Control Register	PUCR2	R/W	Port 2	00000000
1F _H	Port 3 Pull-up Control Register	PUCR3	R/W	Port 3	00000000
20 _H to 37 _H	Reserved				
38 _H	PPG 4 Operation Mode Control Register	PPGC4	W, R/W	16-bit Programmable Pulse Generator 4/5	0X000XX1
39 _H	PPG 5 Operation Mode Control Register	PPGC5	W, R/W		0X000001
3A _H	PPG 45 Clock Select Register	PPG45	R/W		000000X0
3B _H	Program Address Detection Control Status Register 1	PACSR1	R/W	Address Match Detection 1	00000000

(Continued)

MB90350 Series

Address	Register	Abbreviation	Access	Resource name	Initial value
3C _H	PPG 6 Operation Mode Control Register	PPGC6	W, R/W	16-bit Programmable Pulse Generator 6/7	0X000XX1
3D _H	PPG 7 Operation Mode Control Register	PPGC7	W, R/W		0X000001
3E _H	PPG 67 Clock Select Register	PPG67	R/W		000000X0
3F _H	Reserved				
40 _H	PPG 8 Operation Mode Control Register	PPGC8	W, R/W	16-bit Programmable Pulse Generator 8/9	0X000XX1
41 _H	PPG 9 Operation Mode Control Register	PPGC9	W, R/W		0X000001
42 _H	PPG 89 Clock Select Register	PPG89	R/W		000000X0
43 _H	Reserved				
44 _H	PPG A operation mode control register	PPGCA	W, R/W	16-bit Programmable Pulse Generator A/B	0X000XX1
45 _H	PPG B operation mode control register	PPGCB	W, R/W		0X000001
46 _H	PPG AB clock select register	PPGAB	R/W		000000X0
47 _H	Reserved				
48 _H	PPG C Operation Mode Control Register	PPGCC	W,R/W	16-bit Programmable Pulse Generator C/D	0X000XX1
49 _H	PPG D Operation Mode Control Register	PPGCD	W,R/W		0X000001
4A _H	PPG CD Clock Select Register	PPGCD	R/W		000000X0
4B _H	Reserved				
4C _H	PPG E Operation Mode Control Register	PPGCE	W,R/W	16-bit Programmable Pulse Generator E/F	0X000XX1
4D _H	PPG F Operation Mode Control Register	PPGCF	W,R/W		0X000001
4E _H	PPG EF Clock Select Register	PPGEF	R/W		000000X0
4F _H	Reserved				
50 _H	Input Capture Control Status Register 0/1	ICS01	R/W	Input Capture 0/1	00000000
51 _H	Input Capture Edge Register 0/1	ICE01	R/W, R		XXX0X0XX
52 _H , 53 _H	Reserved				
54 _H	Input Capture Control Status Register 4/5	ICS45	R/W	Input Capture 4/5	00000000
55 _H	Input Capture Edge Register 4/5	ICE45	R		XXXXXXXXXX
56 _H	Input Capture Control Status Register 6/7	ICS67	R/W	Input Capture 6/7	00000000
57 _H	Input Capture Edge Register 6/7	ICE67	R/W, R		XXX000XX
58 _H to 5B _H	Reserved				
5C _H	Output Compare Control Status Register 4	OCS4	R/W	Output Compare 4/5	0000XX00
5D _H	Output Compare Control Status Register 5	OCS5	R/W		0XX00000

(Continued)

MB90350 Series

Address	Register	Abbrevia- tion	Access	Resource name	Initial value
5E _H	Output Compare Control Status Register 6	OCS6	R/W	Output Compare 6/7	0000XX00
5F _H	Output Compare Control Status Register 7	OCS7	R/W		0XX00000
60 _H	Timer Control Status Register 0	TMCSR0	R/W	16-bit Reload Timer 0	00000000
61 _H	Timer Control Status Register 0	TMCSR0	R/W		XXXX0000
62 _H	Timer Control Status Register 1	TMCSR1	R/W	16-bit Reload Timer 1	00000000
63 _H	Timer Control Status Register 1	TMCSR1	R/W		XXXX0000
64 _H	Timer Control Status Register 2	TMCSR2	R/W	16-bit Reload Timer 2	00000000
65 _H	Timer Control Status Register 2	TMCSR2	R/W		XXXX0000
66 _H	Timer Control Status Register 3	TMCSR3	R/W	16-bit Reload Timer 3	00000000
67 _H	Timer Control Status Register 3	TMCSR3	R/W		XXXX0000
68 _H	A/D Control Status Register 0	ADCS0	R/W	A/D Converter	000XXXX0
69 _H	A/D Control Status Register 1	ADCS1	R/W		0000000X
6A _H	Data Register 0	ADCR0	R		00000000
6B _H	Data Register 1	ADCR1	R		XXXXXX00
6C _H	A/D Setting Register 0	ADSR0	R/W		00000000
6D _H	A/D Setting Register 1	ADSR1	R/W		00000000
6E _H	Reserved				
6F _H	ROM Mirroring Register	ROMM	W	ROM Mirror	XXXXXXXX1
70 _H to 7F _H	Reserved				
80 _H to 8F _H	Reserved for CAN Interface 1. Refer to “■ CAN CONTROLLERS”				
90 _H to 9A _H	Reserved				
9B _H	DMA Descriptor Channel Specification Register	DCSR	R/W	DMA	00000000
9C _H	DMA Status Register L	DSRL	R/W		00000000
9D _H	DMA Status Register H	DSRH	R/W		00000000
9E _H	Program Address Detection Control Status Register 0	PACSR0	R/W	Address Match Detection 0	00000000
9F _H	Delayed Interrupt/Release	DIRR	R/W	Delayed Interrupt	00000000
A0 _H	Low-power Mode Control Register	LPMCR	W,R/W	Low Power Control Circuit	00011000
A1 _H	Clock Selection Register	CKSCR	R,R/W	Low Power Control Circuit	11111100
A2 _H , A3 _H	Reserved				
A4 _H	DMA Stop Status Register	DSSR	R/W	DMA	00000000

(Continued)

MB90350 Series

Address	Register	Abbrevia- tion	Access	Resource name	Initial value
A5 _H	Automatic Ready Function Selection Register	ARSR	W	External Memory Access	0011XX00
A6 _H	External Address Output Control Register	HACR	W		00000000
A7 _H	Bus Control Signal Selection Register	ECSR	W		0000000X
A8 _H	Watchdog Timer Control Register	WDTC	R,W	Watchdog Timer	XXXXX111
A9 _H	Timebase Timer Control Register	TBTC	W,R/W	Time base timer	1XX00100
AA _H	Watch Timer Control Register	WTC	R,R/W	Watch timer	1X001000
AB _H	Reserved				
AC _H	DMA Enable Register L	DERL	R/W	DMA	00000000
AD _H	DMA Enable Register H	DERH	R/W		00000000
AE _H	Flash Control Status Register (Flash Devices only. Otherwise reserved)	FMCS	R,R/W	Flash Memory	000X0000
AF _H	Reserved				
B0 _H	Interrupt Control Register 00	ICR00	W,R/W	Interrupt Control	00000111
B1 _H	Interrupt Control Register 01	ICR01	W,R/W		00000111
B2 _H	Interrupt Control Register 02	ICR02	W,R/W		00000111
B3 _H	Interrupt Control Register 03	ICR03	W,R/W		00000111
B4 _H	Interrupt Control Register 04	ICR04	W,R/W		00000111
B5 _H	Interrupt Control Register 05	ICR05	W,R/W		00000111
B6 _H	Interrupt Control Register 06	ICR06	W,R/W		00000111
B7 _H	Interrupt Control Register 07	ICR07	W,R/W		00000111
B8 _H	Interrupt Control Register 08	ICR08	W,R/W		00000111
B9 _H	Interrupt Control Register 09	ICR09	W,R/W		00000111
BA _H	Interrupt Control Register 10	ICR10	W,R/W		00000111
BB _H	Interrupt Control Register 11	ICR11	W,R/W		00000111
BC _H	Interrupt Control Register 12	ICR12	W,R/W		00000111
BD _H	Interrupt Control Register 13	ICR13	W,R/W		00000111
BE _H	Interrupt Control Register 14	ICR14	W,R/W		00000111
BF _H	Interrupt Control Register 15	ICR15	W,R/W		00000111
C0 _H to C9 _H	Reserved				

(Continued)

MB90350 Series

Address	Register	Abbrevia- tion	Access	Resource name	Initial value
CA _H	External Interrupt Request Enable Register 1	ENIR1	R/W	External Interrupt 1	00000000
CB _H	External Interrupt Request Register 1	EIRR1	R/W		XXXXXXXX
CC _H	External Interrupt Level Register 1	ELVR1	R/W		00000000
CD _H	External Interrupt Level Register 1	ELVR1	R/W		00000000
CE _H	External Interrupt Source Select Register	EISSR	R/W		00000000
CF _H	PLL/Subclock Control register	PSCCR	W	PLL	XXXX0000
D0 _H	DMA Buffer Address Pointer L	BAPL	R/W	DMA	XXXXXXXX
D1 _H	DMA Buffer Address Pointer M	BAPM	R/W		XXXXXXXX
D2 _H	DMA Buffer Address Pointer H	BAPH	R/W		XXXXXXXX
D3 _H	DMA Control Register	DMACS	R/W		XXXXXXXX
D4 _H	I/O Register Address Pointer L	IOAL	R/W		XXXXXXXX
D5 _H	I/O Register Address Pointer H	IOAH	R/W		XXXXXXXX
D6 _H	Data Counter L	DCTL	R/W		XXXXXXXX
D7 _H	Data Counter H	DCTH	R/W		XXXXXXXX
D8 _H	Serial Mode Register 2	SMR2	W,R/W	UART2	00000000
D9 _H	Serial Control Register 2	SCR2	W,R/W		00000000
DA _H	Reception/Transmission Data Register 2	RDR2/ TDR2	R/W		00000000
DB _H	Serial Status Register 2	SSR2	R,R/W		00001000
DC _H	Extended Communication Control Register 2	ECCR2	R,W, R/W		000000XX
DD _H	Extended Status/Control Register 2	ESCR2	R/W		00000100
DE _H	Baud Rate Reload Register 20	BGR20	R/W		00000000
DF _H	Baud Rate Reload Register 21	BGR21	R/W		00000000
E0 _H to EF _H	Reserved				
F0 _H to FF _H	External				
7900 _H to 7907 _H	Reserved				

(Continued)

MB90350 Series

Address	Register	Abbrevia- tion	Access	Resource name	Initial value
7908 _H	Reload Register L4	PRL4	R/W	16-bit Programmable Pulse Generator 4/5	XXXXXXXX
7909 _H	Reload Register H4	PRLH4	R/W		XXXXXXXX
790A _H	Reload Register L5	PRL5	R/W		XXXXXXXX
790B _H	Reload Register H5	PRLH5	R/W		XXXXXXXX
790C _H	Reload Register L6	PRL6	R/W	16-bit Programmable Pulse Generator 6/7	XXXXXXXX
790D _H	Reload Register H6	PRLH6	R/W		XXXXXXXX
790E _H	Reload Register L7	PRL7	R/W		XXXXXXXX
790F _H	Reload Register H7	PRLH7	R/W		XXXXXXXX
7910 _H	Reload Register L8	PRL8	R/W	16-bit Programmable Pulse Generator 8/9	XXXXXXXX
7911 _H	Reload Register H8	PRLH8	R/W		XXXXXXXX
7912 _H	Reload Register L9	PRL9	R/W		XXXXXXXX
7913 _H	Reload Register H9	PRLH9	R/W		XXXXXXXX
7914 _H	Reload Register LA	PRLA	R/W	16-bit Programmable Pulse Generator A/B	XXXXXXXX
7915 _H	Reload Register HA	PRLHA	R/W		XXXXXXXX
7916 _H	Reload Register LB	PRLB	R/W		XXXXXXXX
7917 _H	Reload Register HB	PRLHB	R/W		XXXXXXXX
7918 _H	Reload Register LC	PRLC	R/W	16-bit Programmable Pulse Generator C/D	XXXXXXXX
7919 _H	Reload Register HC	PRLHC	R/W		XXXXXXXX
791A _H	Reload Register LD	PRLD	R/W		XXXXXXXX
791B _H	Reload Register HD	PRLHD	R/W		XXXXXXXX
791C _H	Reload Register LE	PRLLE	R/W	16-bit Programmable Pulse Generator E/F	XXXXXXXX
791D _H	Reload Register HE	PRLHE	R/W		XXXXXXXX
791E _H	Reload Register LF	PRLLF	R/W		XXXXXXXX
791F _H	Reload Register HF	PRLHF	R/W		XXXXXXXX
7920 _H	Input Capture Data Register 0	IPCP0	R	Input Capture 0/1	XXXXXXXX
7921 _H	Input Capture Data Register 0	IPCP0	R		XXXXXXXX
7922 _H	Input Capture Data Register 1	IPCP1	R		XXXXXXXX
7923 _H	Input Capture Data Register 1	IPCP1	R		XXXXXXXX
7924 _H to 7927 _H	Reserved				
7928 _H	Input Capture Data Register 4	IPCP4	R	Input Capture 4/5	XXXXXXXX
7929 _H	Input Capture Data Register 4	IPCP4	R		XXXXXXXX
792A _H	Input Capture Data Register 5	IPCP5	R		XXXXXXXX
792B _H	Input Capture Data Register 5	IPCP5	R		XXXXXXXX

(Continued)

MB90350 Series

Address	Register	Abbrevia- tion	Access	Resource name	Initial value
792C _H	Input Capture Data Register 6	IPCP6	R	Input Capture 6/7	XXXXXXXX
792D _H	Input Capture Data Register 6	IPCP6	R		XXXXXXXX
792E _H	Input Capture Data Register 7	IPCP7	R		XXXXXXXX
792F _H	Input Capture Data Register 7	IPCP7	R		XXXXXXXX
7930 _H to 7937 _H	Reserved				
7938 _H	Output Compare Register 4	OCCP4	R/W	Output Compare 4/5	XXXXXXXX
7939 _H	Output Compare Register 4	OCCP4	R/W		XXXXXXXX
793A _H	Output Compare Register 5	OCCP5	R/W		XXXXXXXX
793B _H	Output Compare Register 5	OCCP5	R/W		XXXXXXXX
793C _H	Output Compare Register 6	OCCP6	R/W	Output Compare 6/7	XXXXXXXX
793D _H	Output Compare Register 6	OCCP6	R/W		XXXXXXXX
793E _H	Output Compare Register 7	OCCP7	R/W		XXXXXXXX
793F _H	Output Compare Register 7	OCCP7	R/W		XXXXXXXX
7940 _H	Data Register 0	TCDT0	R/W	I/O Timer 0	00000000
7941 _H	Data Register 0	TCDT0	R/W		00000000
7942 _H	Control status Register 0	TCCSL0	R/W		00000000
7943 _H	Control status Register 0	TCCSH0	R/W		0XXXXXXXX
7944 _H	Data Register 1	TCDT1	R/W	I/O Timer 1	00000000
7945 _H	Data Register 1	TCDT1	R/W		00000000
7946 _H	Control status Register 1	TCCSL1	R/W		00000000
7947 _H	Control status Register 1	TCCSH1	R/W		0XXXXXXXX
7948 _H	Timer Register 0/Reload Register 0	TMR0/ TMRLR0	R/W	16-bit Reload Timer 0	XXXXXXXX
7949 _H			R/W		XXXXXXXX
794A _H	Timer Register 1/Reload Register 1	TMR1/ TMRLR1	R/W	16-bit Reload Timer 1	XXXXXXXX
794B _H			R/W		XXXXXXXX
794C _H	Timer Register 2/Reload Register 2	TMR2/ TMRLR2	R/W	16-bit Reload Timer 2	XXXXXXXX
794D _H			R/W		XXXXXXXX
794E _H	Timer Register 3/Reload Register 3	TMR3/ TMRLR3	R/W	16-bit Reload Timer 3	XXXXXXXX
794F _H			R/W		XXXXXXXX

(Continued)

MB90350 Series

Address	Register	Abbrevia- tion	Access	Resource name	Initial value
7950 _H	Serial Mode Register 3	SMR3	W, R/W	UART3	00000000
7951 _H	Serial Control Register 3	SCR3	W, R/W		00000000
7952 _H	Reception/Transmission Data Register 3	RDR3/ TDR3	R/W		00000000
7953 _H	Serial Status Register 3	SSR3	R,R/W		00001000
7954 _H	Extended Communication Control Register 3	ECCR3	R,W, R/W		000000XX
7955 _H	Extended Status/Control Register 3	ESCR3	R/W		00000100
7956 _H	Baud Rate Reload Register 30	BGR30	R/W		00000000
7957 _H	Baud Rate Reload Register 31	BGR31	R/W		00000000
7958 _H to 796D _H	Reserved				
796E _H	CAN Direct Mode Register	CDMR	R/W	CAN clock sync	XXXXXXXX0
796F _H	Reserved				
7970 _H	I ² C Bus Status Register 0	IBSR0	R	I ² C Interface 0	00000000
7971 _H	I ² C Bus Control Register 0	IBCR0	W,R/W		00000000
7972 _H	I ² C 10 bit Slave Address Register 0	ITBAL0	R/W		00000000
7973 _H		ITBAH0	R/W		00000000
7974 _H	I ² C 10 bit Slave Address Mask Register 0	ITMKL0	R/W		11111111
7975 _H		ITMKH0	R/W		00111111
7976 _H	I ² C 7 bit Slave Address Register 0	ISBA0	R/W		00000000
7977 _H	I ² C 7 bit Slave Address Mask Register 0	ISMK0	R/W		01111111
7978 _H	I ² C data register 0	IDAR0	R/W	00000000	
7979 _H , 797A _H	Reserved				
797B _H	I ² C Clock Control Register 0	ICCR0	R/W	I ² C Interface 0	00011111
797C _H to 79C1 _H	Reserved				
79C2 _H	Clock Modulator Control Register	CMCR	R,R/W	Clock Modulator	0001X000
79C3 _H to 79DF _H	Reserved				

(Continued)

MB90350 Series

(Continued)

Address	Register	Abbrevia- tion	Access	Resource name	Initial value
79E0 _H	Program Address Detection Register 0	PADR0	R/W	Address Match Detection 0	XXXXXXXX
79E1 _H	Program Address Detection Register 0	PADR0	R/W		XXXXXXXX
79E2 _H	Program Address Detection Register 0	PADR0	R/W		XXXXXXXX
79E3 _H	Program Address Detection Register 1	PADR1	R/W		XXXXXXXX
79E4 _H	Program Address Detection Register 1	PADR1	R/W		XXXXXXXX
79E5 _H	Program Address Detection Register 1	PADR1	R/W		XXXXXXXX
79E6 _H	Program Address Detection Register 2	PADR2	R/W		XXXXXXXX
79E7 _H	Program Address Detection Register 2	PADR2	R/W		XXXXXXXX
79E8 _H	Program Address Detection Register 2	PADR2	R/W		XXXXXXXX
79E9 _H to 79EF _H	Reserved				
79F0 _H	Program Address Detection Register 3	PADR3	R/W	Address Match Detection 1	XXXXXXXX
79F1 _H	Program Address Detection Register 3	PADR3	R/W		XXXXXXXX
79F2 _H	Program Address Detection Register 3	PADR3	R/W		XXXXXXXX
79F3 _H	Program Address Detection Register 4	PADR4	R/W		XXXXXXXX
79F4 _H	Program Address Detection Register 4	PADR4	R/W		XXXXXXXX
79F5 _H	Program Address Detection Register 4	PADR4	R/W		XXXXXXXX
79F6 _H	Program Address Detection Register 5	PADR5	R/W		XXXXXXXX
79F7 _H	Program Address Detection Register 5	PADR5	R/W		XXXXXXXX
79F8 _H	Program Address Detection Register 5	PADR5	R/W		XXXXXXXX
79F9 _H to 7BFF _H	Reserved				
7C00 _H to 7CFF _H	Reserved for CAN Interface 1. Refer to "■ CAN CONTROLLERS"				
7D00 _H to 7DFF _H	Reserved for CAN Interface 1. Refer to "■ CAN CONTROLLERS"				
7E00 _H to 7FFF _H	Reserved				

Notes : • Initial value of "X" represents unknown value.

- Addresses in the range 0000_H to 00BF_H, which are not listed in the table, are reserved for the primary functions of the MCU. A read access to these reserved addresses results reading "X" and any write access should not be performed.

■ CAN CONTROLLERS

The CAN controller has the following features :

- Conforms to CAN Specification Version 2.0 Part A and B
 - Supports transmission/reception in standard frame and extended frame formats
- Supports transmitting of data frames by receiving remote frames
- 16 transmitting/receiving message buffers
 - 29-bit ID and 8-byte data
 - Multi-level message buffer configuration
- Provides full-bit comparison, full-bit mask, acceptance register 0/acceptance register 1 for each message buffer as ID acceptance mask
 - Two acceptance mask registers in either standard frame format or extended frame formats
- Bit rate programmable from 10 Kbits/s to 2 Mbits/s (when input clock is at 16 MHz)

List of Control Registers (1)

Address	Register	Abbreviation	Access	Initial Value
CAN1				
000080 _H	Message buffer enable register	BVALR	R/W	00000000
000081 _H				00000000
000082 _H	Transmit request register	TREQR	R/W	00000000
000083 _H				00000000
000084 _H	Transmit cancel register	TCANR	W	00000000
000085 _H				00000000
000086 _H	Transmission complete register	TCR	R/W	00000000
000087 _H				00000000
000088 _H	Receive complete register	RCR	R/W	00000000
000089 _H				00000000
00008A _H	Remote request receiving register	RRTRR	R/W	00000000
00008B _H				00000000
00008C _H	Receive overrun register	ROVRR	R/W	00000000
00008D _H				00000000
00008E _H	Reception interrupt enable register	RIER	R/W	00000000
00008F _H				00000000

MB90350 Series

List of Control Registers (2)

Address	Register	Abbreviation	Access	Initial Value
CAN1				
007D00 _H	Control status register	CSR	R/W, W R/W, R	0XXXX0X1 00XXX000
007D01 _H				
007D02 _H	Last event indicator register	LEIR	R/W	000X0000 XXXXXXXX
007D03 _H				
007D04 _H	Receive/transmit error counter	RTEC	R	00000000 00000000
007D05 _H				
007D06 _H	Bit timing register	BTR	R/W	11111111 X1111111
007D07 _H				
007D08 _H	IDE register	IDER	R/W	XXXXXXXX XXXXXXXX
007D09 _H				
007D0A _H	Transmit RTR register	TRTRR	R/W	00000000 00000000
007D0B _H				
007D0C _H	Remote frame receive waiting register	RFWTR	R/W	XXXXXXXX XXXXXXXX
007D0D _H				
007D0E _H	Transmit interrupt enable register	TIER	R/W	00000000 00000000
007D0F _H				
007D10 _H	Acceptance mask select register	AMSR	R/W	XXXXXXXX XXXXXXXX
007D11 _H				
007D12 _H				XXXXXXXX XXXXXXXX
007D13 _H				
007D14 _H	Acceptance mask register 0	AMR0	R/W	XXXXXXXX XXXXXXXX
007D15 _H				
007D16 _H				XXXXXXXX XXXXXXXX
007D17 _H				
007D18 _H	Acceptance mask register 1	AMR1	R/W	XXXXXXXX XXXXXXXX
007D19 _H				
007D1A _H				XXXXXXXX XXXXXXXX
007D1B _H				

List of Message Buffers (ID Registers) (1)

Address	Register	Abbreviation	Access	Initial Value
CAN1				
007C00 _H to 007C1F _H	General-purpose RAM	—	R/W	XXXXXXXX to XXXXXXXX
007C20 _H	ID register 0	IDR0	R/W	XXXXXXXX XXXXXXXX
007C21 _H				XXXXXXXX XXXXXXXX
007C22 _H				XXXXXXXX XXXXXXXX
007C23 _H				XXXXXXXX XXXXXXXX
007C24 _H	ID register 1	IDR1	R/W	XXXXXXXX XXXXXXXX
007C25 _H				XXXXXXXX XXXXXXXX
007C26 _H				XXXXXXXX XXXXXXXX
007C27 _H				XXXXXXXX XXXXXXXX
007C28 _H	ID register 2	IDR2	R/W	XXXXXXXX XXXXXXXX
007C29 _H				XXXXXXXX XXXXXXXX
007C2A _H				XXXXXXXX XXXXXXXX
007C2B _H				XXXXXXXX XXXXXXXX
007C2C _H	ID register 3	IDR3	R/W	XXXXXXXX XXXXXXXX
007C2D _H				XXXXXXXX XXXXXXXX
007C2E _H				XXXXXXXX XXXXXXXX
007C2F _H				XXXXXXXX XXXXXXXX
007C30 _H	ID register 4	IDR4	R/W	XXXXXXXX XXXXXXXX
007C31 _H				XXXXXXXX XXXXXXXX
007C32 _H				XXXXXXXX XXXXXXXX
007C33 _H				XXXXXXXX XXXXXXXX
007C34 _H	ID register 5	IDR5	R/W	XXXXXXXX XXXXXXXX
007C35 _H				XXXXXXXX XXXXXXXX
007C36 _H				XXXXXXXX XXXXXXXX
007C37 _H				XXXXXXXX XXXXXXXX
007C38 _H	ID register 6	IDR6	R/W	XXXXXXXX XXXXXXXX
007C39 _H				XXXXXXXX XXXXXXXX
007C3A _H				XXXXXXXX XXXXXXXX
007C3B _H				XXXXXXXX XXXXXXXX
007C3C _H	ID register 7	IDR7	R/W	XXXXXXXX XXXXXXXX
007C3D _H				XXXXXXXX XXXXXXXX
007C3E _H				XXXXXXXX XXXXXXXX
007C3F _H				XXXXXXXX XXXXXXXX

MB90350 Series

List of Message Buffers (ID Registers) (2)

Address	Register	Abbreviation	Access	Initial Value
CAN1				
007C40 _H	ID register 8	IDR8	R/W	XXXXXXXX
007C41 _H				XXXXXXXX
007C42 _H				XXXXXXXX
007C43 _H				XXXXXXXX
007C44 _H	ID register 9	IDR9	R/W	XXXXXXXX
007C45 _H				XXXXXXXX
007C46 _H				XXXXXXXX
007C47 _H				XXXXXXXX
007C48 _H	ID register 10	IDR10	R/W	XXXXXXXX
007C49 _H				XXXXXXXX
007C4A _H				XXXXXXXX
007C4B _H				XXXXXXXX
007C4C _H	ID register 11	IDR11	R/W	XXXXXXXX
007C4D _H				XXXXXXXX
007C4E _H				XXXXXXXX
007C4F _H				XXXXXXXX
007C50 _H	ID register 12	IDR12	R/W	XXXXXXXX
007C51 _H				XXXXXXXX
007C52 _H				XXXXXXXX
007C53 _H				XXXXXXXX
007C54 _H	ID register 13	IDR13	R/W	XXXXXXXX
007C55 _H				XXXXXXXX
007C56 _H				XXXXXXXX
007C57 _H				XXXXXXXX
007C58 _H	ID register 14	IDR14	R/W	XXXXXXXX
007C59 _H				XXXXXXXX
007C5A _H				XXXXXXXX
007C5B _H				XXXXXXXX
007C5C _H	ID register 15	IDR15	R/W	XXXXXXXX
007C5D _H				XXXXXXXX
007C5E _H				XXXXXXXX
007C5F _H				XXXXXXXX

List of Message Buffers (DLC Registers and Data Registers) (1)

Address	Register	Abbreviation	Access	Initial Value
CAN1				
007C60 _H	DLC register 0	DLCR0	R/W	XXXXXXXX
007C61 _H				
007C62 _H	DLC register 1	DLCR1	R/W	XXXXXXXX
007C63 _H				
007C64 _H	DLC register 2	DLCR2	R/W	XXXXXXXX
007C65 _H				
007C66 _H	DLC register 3	DLCR3	R/W	XXXXXXXX
007C67 _H				
007C68 _H	DLC register 4	DLCR4	R/W	XXXXXXXX
007C69 _H				
007C6A _H	DLC register 5	DLCR5	R/W	XXXXXXXX
007C6B _H				
007C6C _H	DLC register 6	DLCR6	R/W	XXXXXXXX
007C6D _H				
007C6E _H	DLC register 7	DLCR7	R/W	XXXXXXXX
007C6F _H				
007C70 _H	DLC register 8	DLCR8	R/W	XXXXXXXX
007C71 _H				
007C72 _H	DLC register 9	DLCR9	R/W	XXXXXXXX
007C73 _H				
007C74 _H	DLC register 10	DLCR10	R/W	XXXXXXXX
007C75 _H				
007C76 _H	DLC register 11	DLCR11	R/W	XXXXXXXX
007C77 _H				
007C78 _H	DLC register 12	DLCR12	R/W	XXXXXXXX
007C79 _H				
007C7A _H	DLC register 13	DLCR13	R/W	XXXXXXXX
007C7B _H				
007C7C _H	DLC register 14	DLCR14	R/W	XXXXXXXX
007C7D _H				
007C7E _H	DLC register 15	DLCR15	R/W	XXXXXXXX
007C7F _H				

MB90350 Series

List of Message Buffers (DLC Registers and Data Registers) (2)

Address	Register	Abbreviation	Access	Initial Value
CAN1				
007C80H to 007C87H	Data register 0 (8 bytes)	DTR0	R/W	XXXXXXXX to XXXXXXXX
007C88H to 007C8FH	Data register 1 (8 bytes)	DTR1	R/W	XXXXXXXX to XXXXXXXX
007C90H to 007C97H	Data register 2 (8 bytes)	DTR2	R/W	XXXXXXXX to XXXXXXXX
007C98H to 007C9FH	Data register 3 (8 bytes)	DTR3	R/W	XXXXXXXX to XXXXXXXX
007CA0H to 007CA7H	Data register 4 (8 bytes)	DTR4	R/W	XXXXXXXX to XXXXXXXX
007CA8H to 007CAFH	Data register 5 (8 bytes)	DTR5	R/W	XXXXXXXX to XXXXXXXX
007CB0H to 007CB7H	Data register 6 (8 bytes)	DTR6	R/W	XXXXXXXX to XXXXXXXX
007CB8H to 007CBFH	Data register 7 (8 bytes)	DTR7	R/W	XXXXXXXX to XXXXXXXX
007CC0H to 007CC7H	Data register 8 (8 bytes)	DTR8	R/W	XXXXXXXX to XXXXXXXX
007CC8H to 007CCFH	Data register 9 (8 bytes)	DTR9	R/W	XXXXXXXX to XXXXXXXX
007CD0H to 007CD7H	Data register 10 (8 bytes)	DTR10	R/W	XXXXXXXX to XXXXXXXX
007CD8H to 007CDFH	Data register 11 (8 bytes)	DTR11	R/W	XXXXXXXX to XXXXXXXX
007CE0H to 007CE7H	Data register 12 (8 bytes)	DTR12	R/W	XXXXXXXX to XXXXXXXX
007CE8H to 007CEFH	Data register 13 (8 bytes)	DTR13	R/W	XXXXXXXX to XXXXXXXX

MB90350 Series

List of Message Buffers (DLC Registers and Data Registers) (3)

Address	Register	Abbreviation	Access	Initial Value
CAN1				
007CF0 _H to 007CF7 _H	Data register 14 (8 bytes)	DTR14	R/W	XXXXXXXX to XXXXXXXX
007CF8 _H to 007CFF _H	Data register 15 (8 bytes)	DTR15	R/W	XXXXXXXX to XXXXXXXX

MB90350 Series

■ INTERRUPT FACTORS, INTERRUPT VECTORS, INTERRUPT CONTROL REGISTER

Interrupt cause	EI ² OS clear	DMA ch number	Interrupt vector		Interrupt control register	
			Number	Address	Number	Address
Reset	N	—	#08	FFFFDC _H	—	—
INT9 instruction	N	—	#09	FFFFD8 _H	—	—
Exception	N	—	#10	FFFFD4 _H	—	—
Reserved	N	—	#11	FFFFD0 _H	ICR00	0000B0 _H
Reserved	N	—	#12	FFFFCC _H		
CAN 1 RX / Input Capture 6	Y1	—	#13	FFFFC8 _H	ICR01	0000B1 _H
CAN 1 TX/NS / Input Capture 7	Y1	—	#14	FFFFC4 _H		
I ² C	N	—	#15	FFFFC0 _H	ICR02	0000B2 _H
Reserved	N	—	#16	FFFFBC _H		
16-bit Reload Timer 0	Y1	0	#17	FFFFB8 _H	ICR03	0000B3 _H
16-bit Reload Timer 1	Y1	1	#18	FFFFB4 _H		
16-bit Reload Timer 2	Y1	2	#19	FFFFB0 _H	ICR04	0000B4 _H
16-bit Reload Timer 3	Y1	—	#20	FFFFAC _H		
PPG 4/5	N	—	#21	FFFFA8 _H	ICR05	0000B5 _H
PPG 6/7	N	—	#22	FFFFA4 _H		
PPG 8/9/C/D	N	—	#23	FFFFA0 _H	ICR06	0000B6 _H
PPG A/B/E/F	N	—	#24	FFFF9C _H		
Time Base Timer	N	—	#25	FFFF98 _H	ICR07	0000B7 _H
External Interrupt 8 to 11	Y1	3	#26	FFFF94 _H		
Watch Timer	N	—	#27	FFFF90 _H	ICR08	0000B8 _H
External Interrupt 12 to 15	Y1	4	#28	FFFF8C _H		
A/D Converter	Y1	5	#29	FFFF88 _H	ICR09	0000B9 _H
I/O Timer 0 / I/O Timer 1	N	—	#30	FFFF84 _H		
Input Capture 4/5	Y1	6	#31	FFFF80 _H	ICR10	0000BA _H
Output Compare 4/5	Y1	7	#32	FFFF7C _H		
Input Capture 0/1	Y1	8	#33	FFFF78 _H	ICR11	0000BB _H
Output Compare 6/7	Y1	9	#34	FFFF74 _H		
Reserved	N	10	#35	FFFF70 _H	ICR12	0000BC _H
Reserved	N	11	#36	FFFF6C _H		
UART 3 RX	Y2	12	#37	FFFF68 _H	ICR13	0000BD _H
UART 3 TX	Y1	13	#38	FFFF64 _H		

(Continued)

(Continued)

Interrupt cause	EI ² OS clear	DMA ch number	Interrupt vector		Interrupt control register	
			Number	Address	Number	Address
UART 2 RX	Y2	14	#39	FFFF60H	ICR14	0000BEH
UART 2 TX	Y1	15	#40	FFFF5CH		
Flash Memory	N	—	#41	FFFF58H	ICR15	0000BFH
Delayed interrupt	N	—	#42	FFFF54H		

Y1 : Usable

Y2 : Usable, with EI²OS stop function

N : Unusable

- Notes :
- The peripheral resources sharing the ICR register have the same interrupt level.
 - When two peripheral resources share the ICR register, only one can use Extended Intelligent I/O Service at a time.
 - When either of the two peripheral resources sharing the ICR register specifies Extended Intelligent I/O Service, the other one cannot use interrupts.

MB90350 Series

■ ELECTRICAL CHARACTERISTICS

1. Absolute Maximum Ratings

($V_{SS} = AV_{SS} = 0\text{ V}$)

Parameter	Symbol	Rating		Unit	Remarks
		Min	Max		
Power supply voltage	V_{CC}	$V_{SS} - 0.3$	$V_{SS} + 6.0$	V	
	AV_{CC}	$V_{SS} - 0.3$	$V_{SS} + 6.0$	V	$V_{CC} = AV_{CC}^{*1}$
	$AVRH$	$V_{SS} - 0.3$	$V_{SS} + 6.0$	V	$AV_{CC} \geq AVRH^{*1}$
Input voltage	V_I	$V_{SS} - 0.3$	$V_{SS} + 6.0$	V	*2
Output voltage	V_O	$V_{SS} - 0.3$	$V_{SS} + 6.0$	V	*2
Maximum Clamp Current	I_{CLAMP}	-4.0	+4.0	mA	*4
Total Maximum Clamp Current	$\Sigma I_{CLAMP} $	—	40	mA	*4
"L" level maximum output current	I_{OL}	—	15	mA	*3
"L" level average output current	I_{OLAV}	—	4	mA	*3
"L" level maximum overall output current	ΣI_{OL}	—	100	mA	*3
"L" level average overall output current	ΣI_{OLAV}	—	50	mA	*3
"H" level maximum output current	I_{OH}	—	-15	mA	*3
"H" level average output current	I_{OHAV}	—	-4	mA	*3
"H" level maximum overall output current	ΣI_{OH}	—	-100	mA	*3
"H" level average overall output current	ΣI_{OHAV}	—	-50	mA	*3
Power consumption	P_D	—	240	mW	+105 °C < T_A ≤ +125 °C, Normal operation : maximum frequency 16 MHz
		—	320	mW	-40 °C < T_A ≤ +105 °C, Normal operation : maximum frequency 24 MHz
Operating temperature	T_A	-40	+105	°C	
		-40	+125	°C	*5
Storage temperature	T_{STG}	-55	+150	°C	

(Continued)

(Continued)

- *1: Set AV_{CC} and V_{CC} to the same voltage. Make sure that AV_{CC} does not exceed V_{CC} and that the voltage at the analog inputs does not exceed AV_{CC} when the power is switched on.
- *2: V_i and V_o should not exceed $V_{CC} + 0.3$ V. V_i should not exceed the specified ratings. However if the maximum current to/from an input is limited by some means with external components, the I_{CLAMP} rating supercedes the V_i rating.
- *3: Applicable to pins: P00 to P07, P10 to P17, P20 to P25, P30 to P37, P40 to P45, P50 to P56, P60 to P67
- *4:
 - Applicable to pins: P00 to P07, P10 to P17, P20 to P25, P30 to P37, P40 to P45, P50 to P56 (for evaluation : P50 to P55) , P60 to P67
 - Use within recommended operating conditions.
 - Use at DC voltage (current)
 - The +B signal should always be applied a limiting resistance placed between the +B signal and the microcontroller.
 - The value of the limiting resistance should be set so that when the +B signal is applied the input current to the microcontroller pin does not exceed rated values, either instantaneously or for prolonged periods.
 - Note that when the microcontroller drive current is low, such as in the power saving modes, the +B input potential may pass through the protective diode and increase the potential at the V_{CC} pin, and this may affect other devices.
 - Note that if a +B signal is input when the microcontroller power supply is off (not fixed at 0 V) , the power supply is provided from the pins, so that incomplete operation may result.
 - Note that if the +B input is applied during power-on, the power supply is provided from the pins and the resulting supply voltage may not be sufficient to operate the power-on reset.
 - Care must be taken not to leave the +B input pin open.
 - Sample recommended circuits:

- Input/output equivalent circuits

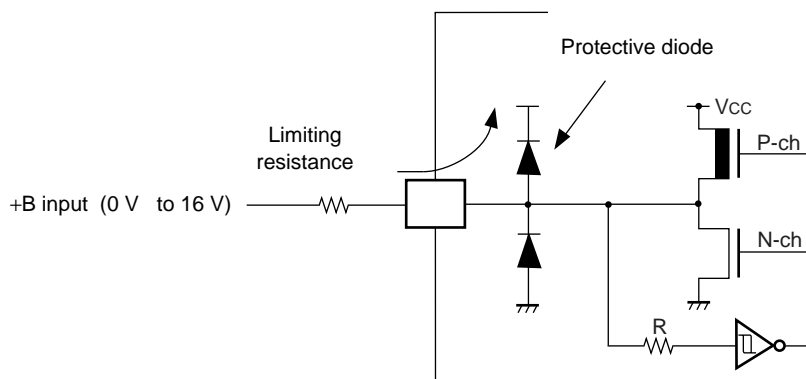

*5 : If used exceeding $T_A = +105$ °C, be sure to contact Fujitsu for reliability limitations.

WARNING: Semiconductor devices can be permanently damaged by application of stress (voltage, current, temperature, etc.) in excess of absolute maximum ratings. Do not exceed these ratings.

MB90350 Series

2. Recommended Conditions

(V_{SS} = AV_{SS} = 0 V)

Parameter	Symbol	Value			Unit	Remarks
		Min	Typ	Max		
Power supply voltage	V _{CC} , AV _{CC}	4.0	5.0	5.5	V	Under normal operation
		3.5	5.0	5.5	V	Under normal operation, when not using the A/D converter and not Flash programming.
		4.5	5.0	5.5	V	When External bus is used.
		3.0	—	5.5	V	Maintains RAM data in stop mode
Smooth capacitor	C _S	0.1	—	1.0	μF	Use a ceramic capacitor or capacitor of better AC characteristics. Capacitor at the V _{CC} should be greater than this capacitor.
Operating temperature	T _A	-40	—	+105	°C	
		-40	—	+125	°C	*

* : If used exceeding T_A = +105 °C, be sure to contact Fujitsu for reliability limitations.

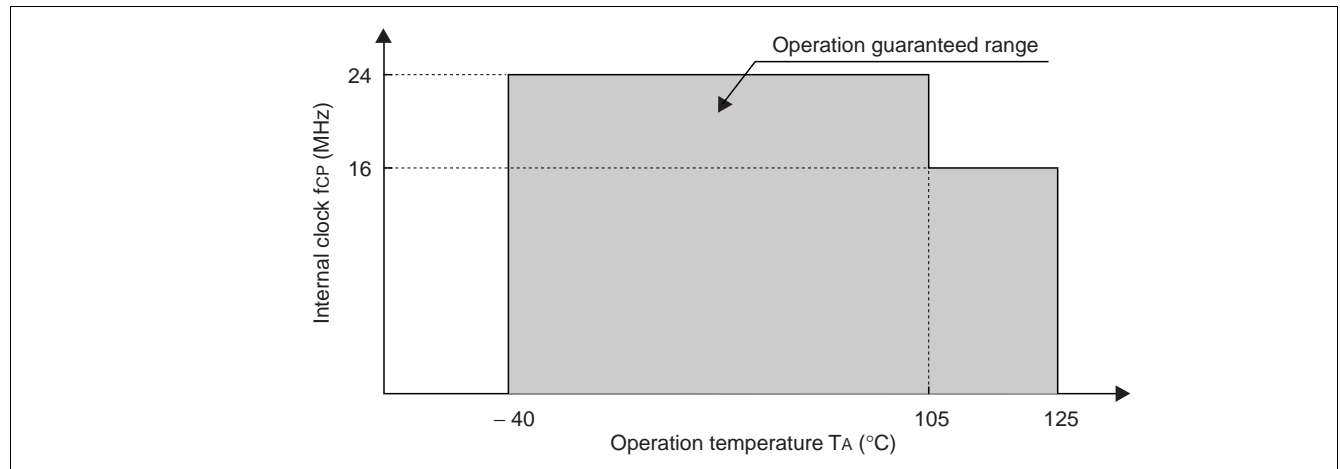
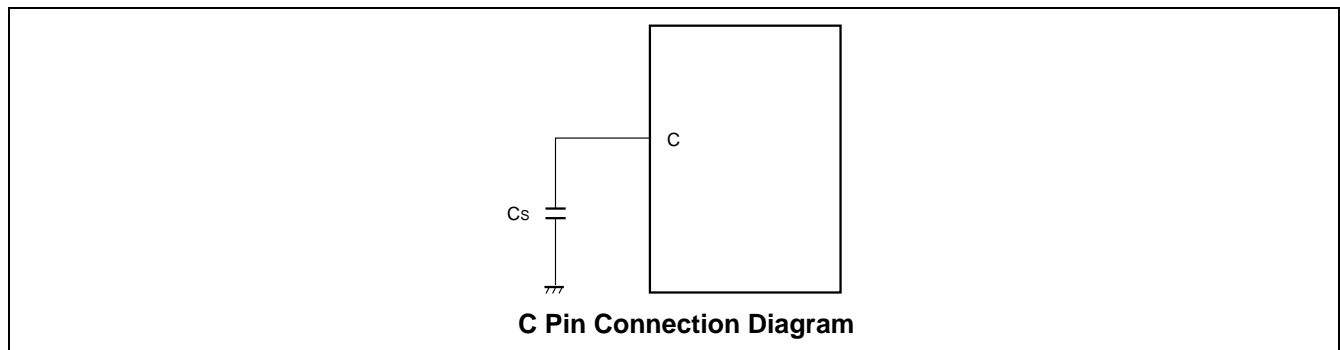

WARNING: The recommended operating conditions are required in order to ensure the normal operation of the semiconductor device. All of the device's electrical characteristics are warranted when the device is operated within these ranges.

Always use semiconductor devices within their recommended operating condition ranges. Operation outside these ranges may adversely affect reliability and could result in device failure.

No warranty is made with respect to uses, operating conditions, or combinations not represented on the data sheet. Users considering application outside the listed conditions are advised to contact their FUJITSU representatives beforehand.

MB90350 Series

3. DC Characteristics

($T_A = -40\text{ }^\circ\text{C}$ to $+105\text{ }^\circ\text{C}$, $V_{CC} = 5.0\text{ V} \pm 10\%$, $f_{CP} \leq 24\text{ MHz}$, $V_{SS} = AV_{SS} = 0\text{ V}$)

($T_A = -40\text{ }^\circ\text{C}$ to $+125\text{ }^\circ\text{C}$, $V_{CC} = 5.0\text{ V} \pm 10\%$, $f_{CP} \leq 16\text{ MHz}$, $V_{SS} = AV_{SS} = 0\text{ V}$)

Parameter	Symbol	Pin	Condition	Value			Unit	Remarks
				Min	Typ	Max		
Input H voltage (At $V_{CC} = 5\text{ V} \pm 10\%$)	V_{IHS}	—	—	$0.8 V_{CC}$	—	$V_{CC} + 0.3$	V	Port inputs if CMOS hysteresis input levels are selected (except P12, P15, P44, P45, P50)
	V_{IHA}	—	—	$0.8 V_{CC}$	—	$V_{CC} + 0.3$	V	Port inputs if AUTOMOTIVE input levels are selected
	V_{IHT}	—	—	2.0	—	$V_{CC} + 0.3$	V	Port inputs if TTL input levels are selected
	V_{IHS}	—	—	$0.7 V_{CC}$	—	$V_{CC} + 0.3$	V	P12, P15, P50 inputs if CMOS input levels are selected
	V_{IHI}	—	—	$0.7 V_{CC}$	—	$V_{CC} + 0.3$	V	P44, P45 inputs if CMOS hysteresis input levels are selected
	V_{IHR}	—	—	$0.8 V_{CC}$	—	$V_{CC} + 0.3$	V	RST input pin (CMOS hysteresis)
	V_{IHM}	—	—	$V_{CC} - 0.3$	—	$V_{CC} + 0.3$	V	MD input pin
Input L voltage (At $V_{CC} = 5\text{ V} \pm 10\%$)	V_{ILS}	—	—	$V_{SS} - 0.3$	—	$0.2 V_{CC}$	V	Port inputs if CMOS hysteresis input levels are selected (except P12, P15, P44, P45, P50)
	V_{ILA}	—	—	$V_{SS} - 0.3$	—	$0.5 V_{CC}$	V	Port inputs if AUTOMOTIVE input levels are selected
	V_{ILT}	—	—	$V_{SS} - 0.3$	—	0.8	V	Port inputs if TTL input levels are selected
	V_{ILS}	—	—	$V_{SS} - 0.3$	—	$0.3 V_{CC}$	V	P12, P15, P50 inputs if CMOS input levels are selected
	V_{ILI}	—	—	$V_{SS} - 0.3$	—	$0.3 V_{CC}$	V	P44, P45 inputs if CMOS hysteresis input levels are selected
	V_{ILR}	—	—	$V_{SS} - 0.3$	—	$0.2 V_{CC}$	V	RST input pin (CMOS hysteresis)
	V_{ILM}	—	—	$V_{SS} - 0.3$	—	$V_{SS} + 0.3$	V	MD input pin
Output H voltage	V_{OH}	Normal outputs	$V_{CC} = 4.5\text{ V}$, $I_{OH} = -4.0\text{ mA}$	$V_{CC} - 0.5$	—	—	V	
Output H voltage	V_{OHI}	I ² C current outputs	$V_{CC} = 4.5\text{ V}$, $I_{OH} = -3.0\text{ mA}$	$V_{CC} - 0.5$	—	—	V	
Output L voltage	V_{OL}	Normal outputs	$V_{CC} = 4.5\text{ V}$, $I_{OL} = 4.0\text{ mA}$	—	—	0.4	V	
Output L voltage	V_{OLI}	I ² C current outputs	$V_{CC} = 4.5\text{ V}$, $I_{OL} = 3.0\text{ mA}$	—	—	0.4	V	

(Continued)

MB90350 Series

(Continued)

($T_A = -40\text{ }^\circ\text{C}$ to $+105\text{ }^\circ\text{C}$, $V_{CC} = 5.0\text{ V} \pm 10\%$, $f_{CP} \leq 24\text{ MHz}$, $V_{SS} = AV_{SS} = 0\text{ V}$)

($T_A = -40\text{ }^\circ\text{C}$ to $+125\text{ }^\circ\text{C}$, $V_{CC} = 5.0\text{ V} \pm 10\%$, $f_{CP} \leq 16\text{ MHz}$, $V_{SS} = AV_{SS} = 0\text{ V}$)

Parameter	Symbol	Pin	Condition	Value			Unit	Remarks
				Min	Typ	Max		
Input leak current	I_{IL}	—	$V_{CC} = 5.5\text{ V}$, $V_{SS} < V_I < V_{CC}$	-1	—	1	μA	
Pull-up resistance	R_{UP}	P00 to P07, P10 to P17, P20 to P25, P30 to P37, \overline{RST}	—	25	50	100	$\text{k}\Omega$	
Pull-down resistance	R_{DOWN}	MD2	—	25	50	100	$\text{k}\Omega$	Except Flash devices
Power supply current*	I_{CC}	V_{CC}	$V_{CC} = 5.0\text{ V}$, Internal frequency : 24 MHz, At normal operation.	—	50	65	mA	MB90F352
			$V_{CC} = 5.0\text{ V}$, Internal frequency : 24 MHz, At writing FLASH memory.	—	65	80	mA	MB90F352
			$V_{CC} = 5.0\text{ V}$, Internal frequency : 24 MHz, At erasing FLASH memory.	—	70	85	mA	MB90F352
			$V_{CC} = 5.0\text{ V}$, Internal frequency : 24 MHz, At Sleep mode.	—	25	35	mA	MB90F352
			$V_{CC} = 5.0\text{ V}$, Internal frequency : 2 MHz, At Main Timer mode	—	0.3	0.8	mA	MB90F352
			$V_{CC} = 5.0\text{ V}$, Internal frequency : 24 MHz, At PLL Timer mode, external frequency = 4 MHz	—	4	7	mA	MB90F352
			$V_{CC} = 5.0\text{ V}$, Internal frequency: 8 kHz, At sub operation $T_A = +25\text{ }^\circ\text{C}$	—	170	360	μA	MB90F352
			$V_{CC} = 5.0\text{ V}$, Internal frequency: 8 kHz, At sub sleep $T_A = +25\text{ }^\circ\text{C}$	—	20	50	μA	MB90F352
			$V_{CC} = 5.0\text{ V}$, Internal frequency: 8 kHz, At watch mode $T_A = +25\text{ }^\circ\text{C}$	—	10	35	μA	MB90F352
			$V_{CC} = 5.0\text{ V}$, At Stop mode, $T_A = +25\text{ }^\circ\text{C}$	—	7	25	μA	MB90F352
Input capacity	C_{IN}	Other than C, AV_{CC} , AV_{SS} , $AVRH$, V_{CC} , V_{SS} ,	—	—	5	15	pF	

* : The power supply current is measured with an external clock.

4. AC Characteristics

(1) Clock Timing

($T_A = -40\text{ }^\circ\text{C}$ to $+105\text{ }^\circ\text{C}$, $V_{CC} = 5.0\text{ V} \pm 10\%$, $f_{CP} \leq 24\text{ MHz}$, $V_{SS} = AV_{SS} = 0\text{ V}$)

($T_A = -40\text{ }^\circ\text{C}$ to $+125\text{ }^\circ\text{C}$, $V_{CC} = 5.0\text{ V} \pm 10\%$, $f_{CP} \leq 16\text{ MHz}$, $V_{SS} = AV_{SS} = 0\text{ V}$)

Parameter	Symbol	Pin	Value			Unit	Remarks
			Min	Typ	Max		
Clock frequency	f_c	X0, X1	3	—	16	MHz	When using an oscillation circuit
		X0	3	—	24	MHz	When using an external clock*
	f_{CL}	X0A, X1A	—	32.768	100	kHz	
Clock cycle time	t_{CYL}	X0, X1	62.5	—	333	ns	When using an oscillation circuit
		X0	41.67	—	333	ns	When using an external clock
	t_{CYLL}	X0A, X1A	10	30.5	—	μs	
Input clock pulse width	P_{WH}, P_{WL}	X0	10	—	—	ns	Duty ratio is about 30% to 70%.
	P_{WHL}, P_{WLL}	X0A	5	15.2	—	μs	
Input clock rise and fall time	t_{CR}, t_{CF}	X0	—	—	5	ns	When using external clock
Internal operating clock frequency (machine clock)	f_{CP}	—	1.5	—	24	MHz	When using main clock at $T_A \leq +105\text{ }^\circ\text{C}$
					16		When using main clock at $T_A \leq +125\text{ }^\circ\text{C}$
	f_{CPL}	—	—	8.192	50	kHz	When using sub clock
Internal operating clock cycle time (machine clock)	t_{CP}	—	41.67	—	666	ns	When using main clock at $T_A \leq +105\text{ }^\circ\text{C}$
			62.5				When using main clock at $T_A \leq +125\text{ }^\circ\text{C}$
	t_{CPL}	—	20	122.1	—	μs	When using sub clock

* : When selecting the PLL clock, the range of clock frequency is limited. Use this product within range as mentioned in "Relation among external clock frequency and machine clock frequency".

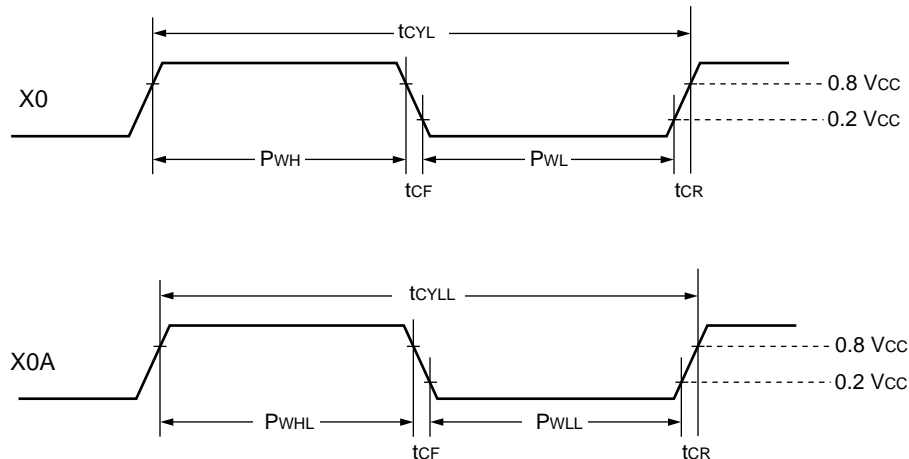

Clock Timing

MB90350 Series

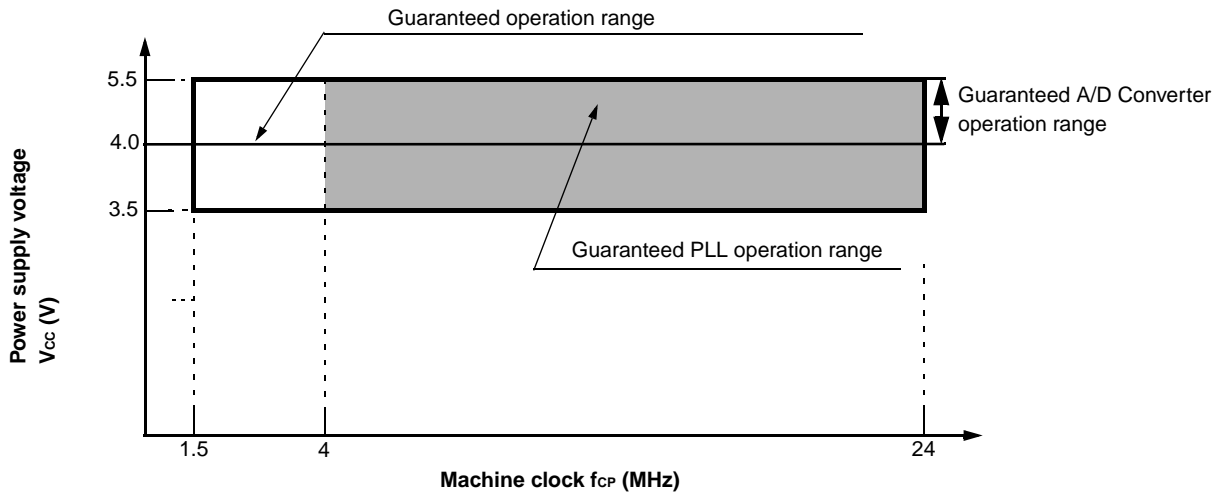

Guaranteed operation range of MB90350 series

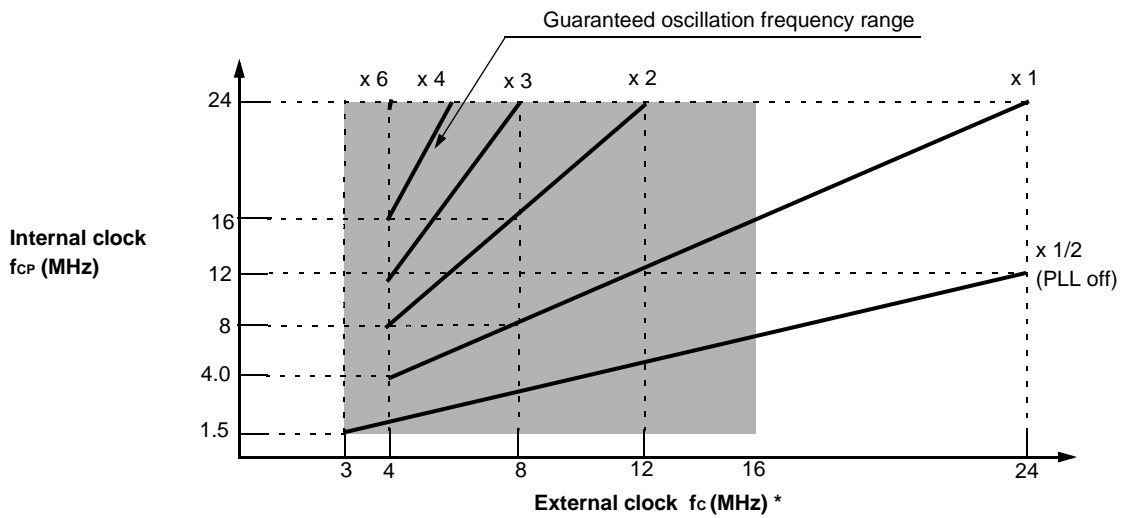

* : When using the oscillation circuit, the maximum oscillation clock frequency is 16 MHz

External clock frequency and Machine clock frequency

(2) Reset Standby Input

($T_A = -40\text{ }^\circ\text{C}$ to $+105\text{ }^\circ\text{C}$, $V_{CC} = 5.0\text{ V} \pm 10\%$, $f_{CP} \leq 24\text{ MHz}$, $V_{SS} = AV_{SS} = 0\text{ V}$)

($T_A = -40\text{ }^\circ\text{C}$ to $+125\text{ }^\circ\text{C}$, $V_{CC} = 5.0\text{ V} \pm 10\%$, $f_{CP} \leq 16\text{ MHz}$, $V_{SS} = AV_{SS} = 0\text{ V}$)

Parameter	Symbol	Pin	Value		Unit	Remarks	
			Min	Max			
Reset input time	t_{RSTL}	\overline{RST}	500	—	ns	Under normal operation	
			Oscillation time of oscillator* + 100 μs		—	μs	In Stop mode, Sub Clock mode, Sub Sleep mode and Watch mode
			100	—	μs	In Main timer mode and PLL timer mode	

* : Oscillation time of oscillator is the time that the amplitude reaches 90%.

In the crystal oscillator, the oscillation time is between several ms to tens of ms. In FAR / ceramic oscillators, the oscillation time is between hundreds of μs to several ms. With an external clock, the oscillation time is 0 ms.

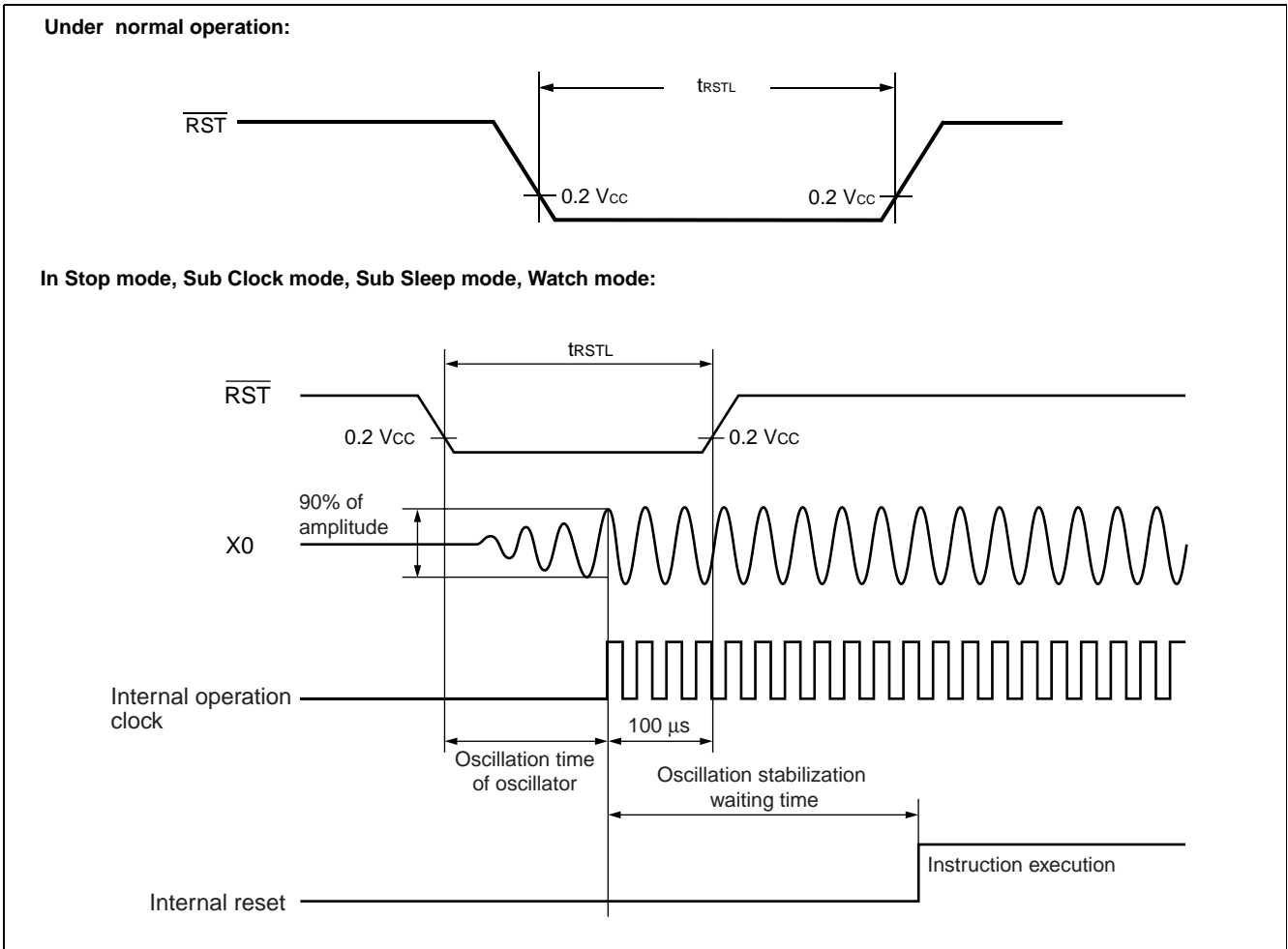

MB90350 Series

(3) Power On Reset

($T_A = -40\text{ }^\circ\text{C}$ to $+105\text{ }^\circ\text{C}$, $V_{CC} = 5.0\text{ V} \pm 10\%$, $f_{CP} \leq 24\text{ MHz}$, $V_{SS} = AV_{SS} = 0\text{ V}$)

($T_A = -40\text{ }^\circ\text{C}$ to $+125\text{ }^\circ\text{C}$, $V_{CC} = 5.0\text{ V} \pm 10\%$, $f_{CP} \leq 16\text{ MHz}$, $V_{SS} = AV_{SS} = 0\text{ V}$)

Parameter	Symbol	Pin	Condition	Value		Unit	Remarks
				Min	Max		
Power on rise time	t_R	V_{CC}	—	0.05	30	ms	
Power off time	t_{OFF}	V_{CC}	—	1	—	ms	Due to repetitive operation

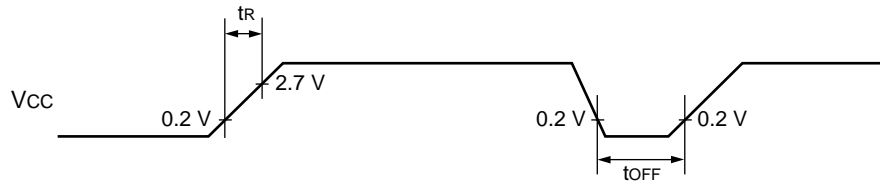

If you change the power supply voltage too rapidly, a power on reset may occur. We recommend that you startup smoothly by restraining voltages when changing the power supply voltage during operation, as shown in the figure below. Perform while not using the PLL clock. However, if voltage drops are within 1 V/s, you can operate while using the PLL clock.

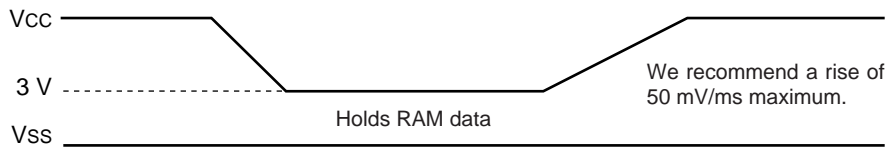

(4) Clock Output Timing

($T_A = -40\text{ }^\circ\text{C}$ to $+105\text{ }^\circ\text{C}$, $V_{CC} = 5.0\text{ V} \pm 10\%$, $V_{SS} = 0.0\text{ V}$, $f_{CP} \leq 24\text{ MHz}$)

Parameter	Symbol	Pin	Condition	Value		Unit	Remarks
				Min	Max		
Cycle time	t_{CYC}	CLK	—	62.5	—	ns	$f_{CP} = 16\text{ MHz}$
				41.76	—	ns	$f_{CP} = 24\text{ MHz}$
CLK $\uparrow \rightarrow$ CLK \downarrow	t_{CHCL}	CLK	—	20	—	ns	$f_{CP} = 16\text{ MHz}$
				13	—	ns	$f_{CP} = 24\text{ MHz}$

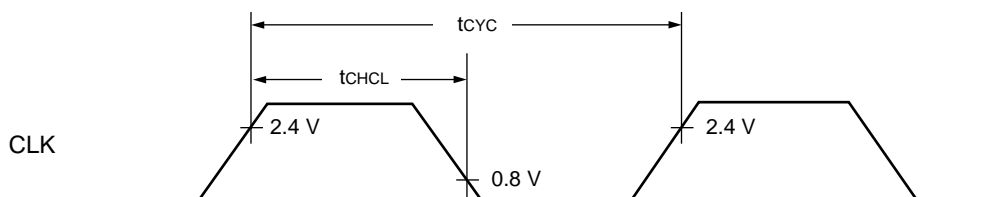

(5) Bus Timing (Read)

($T_A = -40^{\circ}\text{C}$ to $+105^{\circ}\text{C}$, $V_{CC} = 5.0\text{ V} \pm 10\%$, $V_{SS} = 0.0\text{ V}$, $f_{CP} \leq 24\text{ MHz}$)

Parameter	Symbol	Pin	Condition	Value		Unit	Remarks
				Min	Max		
ALE pulse width	t_{LHLL}	ALE	—	$t_{CP}/2 - 10$	—	ns	
Valid address \Rightarrow ALE \downarrow time	t_{AVLL}	ALE, A21 to A16, AD15 to AD00		$t_{CP}/2 - 20$	—	ns	
ALE $\downarrow \Rightarrow$ Address valid time	t_{LLAX}	ALE, AD15 to AD00		$t_{CP}/2 - 15$	—	ns	
Valid address $\Rightarrow \overline{RD} \downarrow$ time	t_{AVRL}	A21 to A16, AD15 to AD00, \overline{RD}		$t_{CP} - 15$	—	ns	
Valid address \Rightarrow Valid data input	t_{AVDV}	A21 to A16, AD15 to AD00		—	$5 t_{CP}/2 - 60$	ns	
\overline{RD} pulse width	t_{RLRH}	\overline{RD}		$3 t_{CP}/2 - 20$	—	ns	
$\overline{RD} \downarrow \Rightarrow$ Valid data input	t_{RLDV}	\overline{RD} , AD15 to AD00		—	$3 t_{CP}/2 - 50$	ns	
$\overline{RD} \uparrow \Rightarrow$ Data hold time	t_{RHDX}	\overline{RD} , AD15 to AD00		0	—	ns	
$\overline{RD} \downarrow \Rightarrow$ ALE \uparrow time	t_{RHLH}	\overline{RD} , ALE		$t_{CP}/2 - 15$	—	ns	
$\overline{RD} \uparrow \Rightarrow$ Address valid time	t_{RHAX}	\overline{RD} , A21 to A16		$t_{CP}/2 - 10$	—	ns	
Valid address \Rightarrow CLK \uparrow time	t_{AVCH}	A21 to A16, AD15 to AD00, CLK		$t_{CP}/2 - 16$	—	ns	
$\overline{RD} \downarrow \Rightarrow$ CLK \uparrow time	t_{RLCH}	\overline{RD} , CLK		$t_{CP}/2 - 15$	—	ns	
ALE $\downarrow \Rightarrow \overline{RD} \downarrow$ time	t_{LLRL}	ALE, \overline{RD}		$t_{CP}/2 - 15$	—	ns	

MB90350 Series

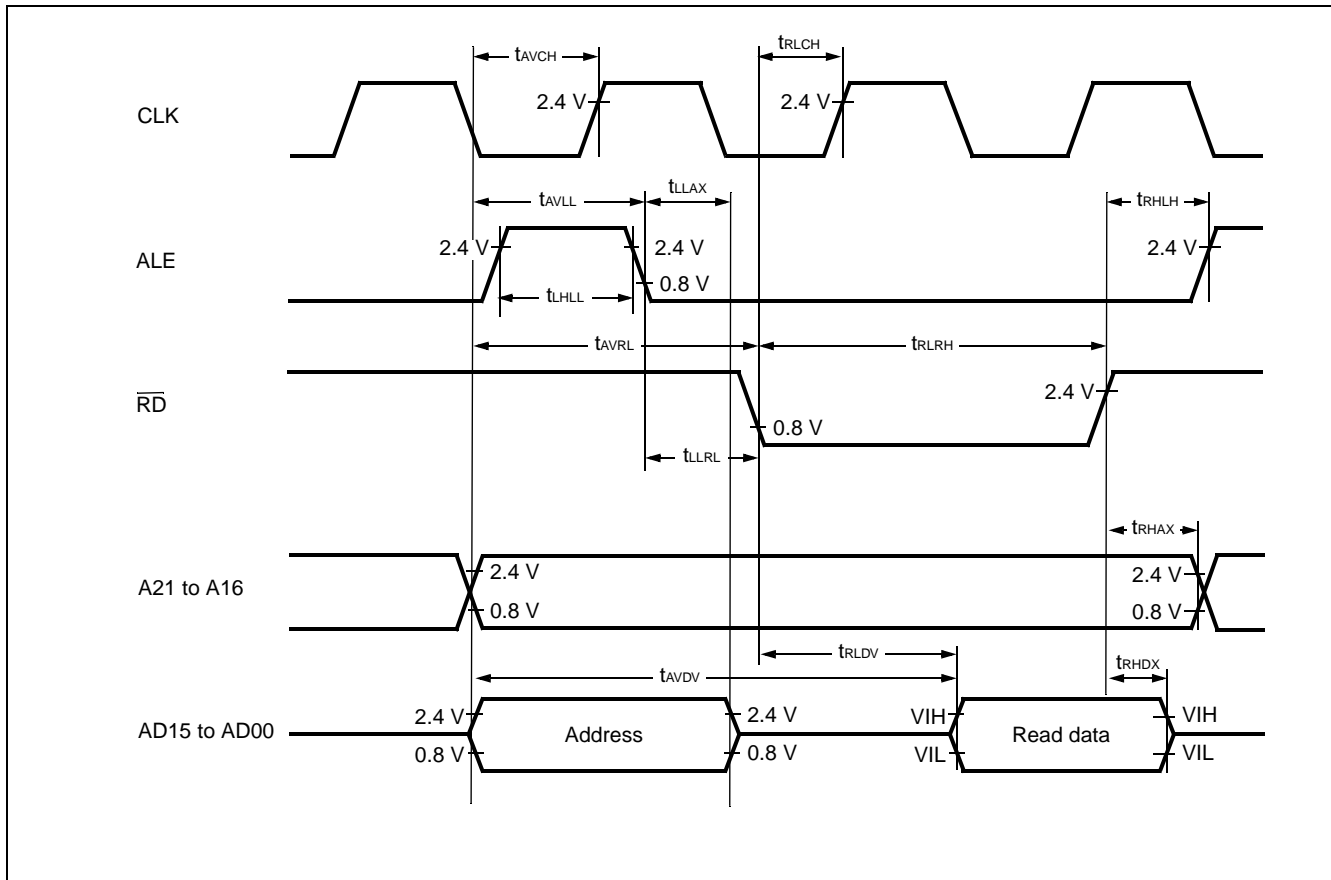

(6) Bus Timing (Write)

($T_A = -40^\circ\text{C}$ to $+105^\circ\text{C}$, $V_{CC} = 5.0\text{ V} \pm 10\%$, $V_{SS} = 0.0\text{ V}$, $f_{CP} \leq 24\text{ MHz}$)

Parameter	Symbol	Pin	Condition	Value		Unit	Remarks
				Min	Max		
Valid address $\Rightarrow \overline{\text{WR}} \downarrow$ time	t_{AVWL}	A21 to A16, AD15 to AD00, $\overline{\text{WR}}$	—	$t_{CP} - 15$	—	ns	
$\overline{\text{WR}}$ pulse width	t_{WLWH}	$\overline{\text{WR}}$		$3 t_{CP} / 2 - 20$	—	ns	
Valid data output $\Rightarrow \overline{\text{WR}} \uparrow$ time	t_{DVWH}	AD15 to AD00, $\overline{\text{WR}}$		$3 t_{CP} / 2 - 20$	—	ns	
$\overline{\text{WR}} \uparrow \Rightarrow$ Data hold time	t_{WHDX}	AD15 to AD00, $\overline{\text{WR}}$		15	—	ns	
$\overline{\text{WR}} \uparrow \Rightarrow$ Address valid time	t_{WHAX}	A21 to A16, $\overline{\text{WR}}$		$t_{CP} / 2 - 10$	—	ns	
$\overline{\text{WR}} \uparrow \Rightarrow$ ALE \uparrow time	t_{WHLH}	$\overline{\text{WR}}$, ALE		$t_{CP} / 2 - 15$	—	ns	
$\overline{\text{WR}} \downarrow \Rightarrow$ CLK \uparrow time	t_{WLCH}	$\overline{\text{WR}}$, CLK		$t_{CP} / 2 - 15$	—	ns	

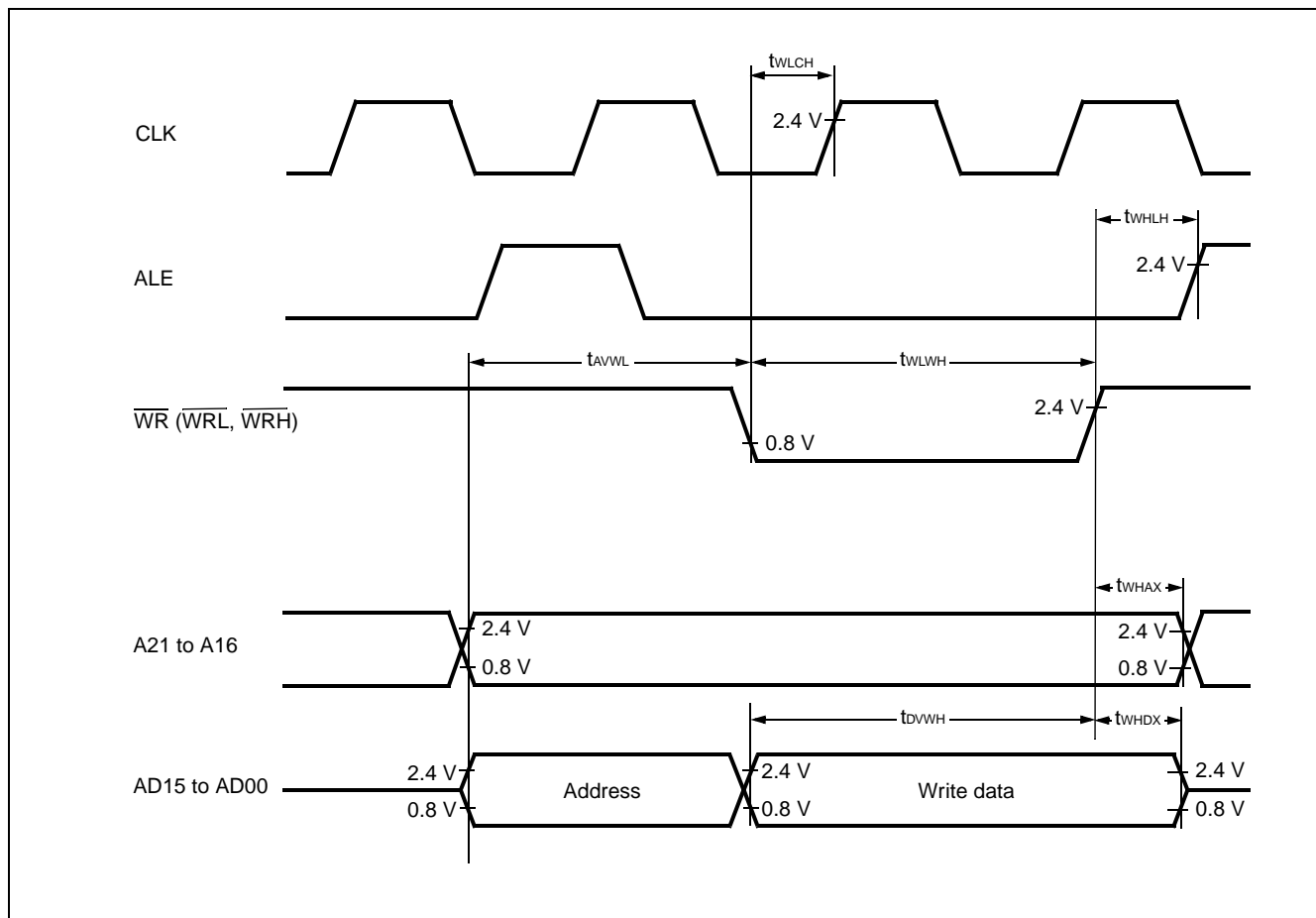

MB90350 Series

(7) Ready Input Timing

($T_A = -40^{\circ}\text{C}$ to $+105^{\circ}\text{C}$, $V_{CC} = 5.0\text{ V} \pm 10\%$, $V_{SS} = 0.0\text{ V}$, $f_{CP} \leq 24\text{ MHz}$)

Parameter	Symbol	Pin	Test Condition	Rated Value		Units	Remarks
				Min	Max		
RDY setup time	t_{RYHS}	RDY	—	45	—	ns	$f_{CP} = 16\text{ MHz}$
				32	—	ns	$f_{CP} = 24\text{ MHz}$
RDY hold time	t_{RYHH}	RDY	—	0	—	ns	

Note : If the RDY setup time is insufficient, use the auto-ready function.

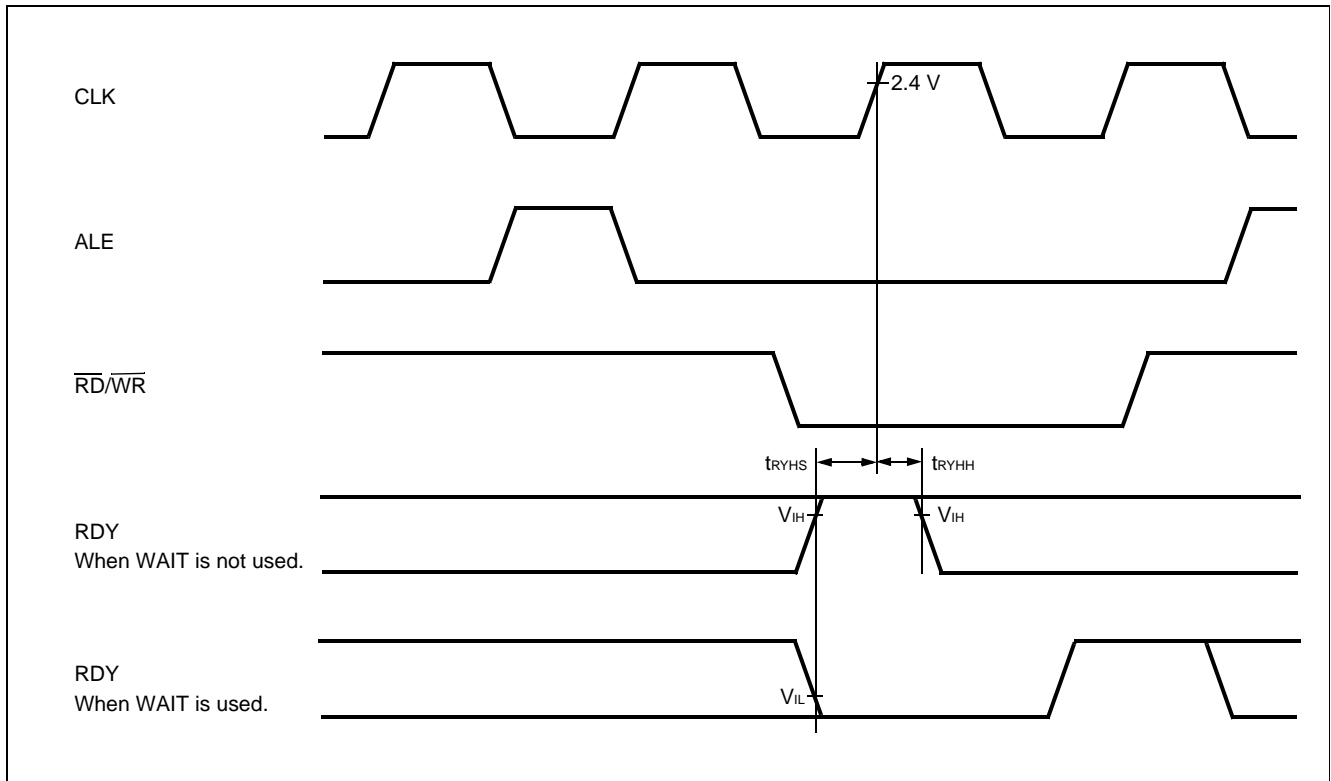

(8) Hold Timing

($T_A = -40^{\circ}\text{C}$ to $+105^{\circ}\text{C}$, $V_{CC} = 5.0\text{ V} \pm 10\%$, $V_{SS} = 0.0\text{ V}$, $f_{CP} \leq 24\text{ MHz}$)

Parameter	Symbol	Pin	Condition	Value		Units	Remarks
				Min	Max		
Pin floating $\Rightarrow \overline{\text{HAK}} \downarrow$ time	t_{XHAL}	$\overline{\text{HAK}}$	—	30	t_{CP}	ns	
$\overline{\text{HAK}} \uparrow$ time \Rightarrow Pin valid time	t_{HAHV}	$\overline{\text{HAK}}$		t_{CP}	$2 t_{\text{CP}}$	ns	

Note : There is more than 1 cycle from when HRQ reads in until the $\overline{\text{HAK}}$ is changed.

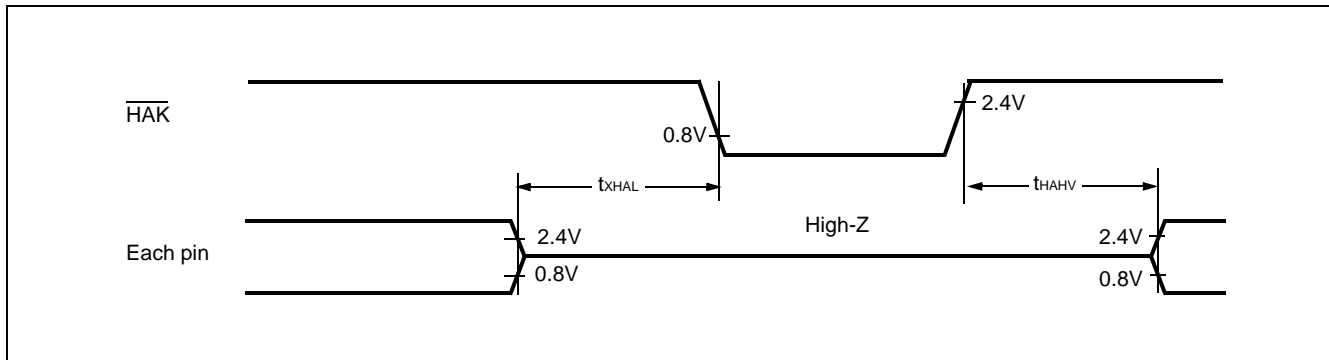

MB90350 Series

(9) UART 2/3

($T_A = -40^\circ\text{C}$ to $+105^\circ\text{C}$, $V_{CC} = 5.0\text{ V} \pm 10\%$, $f_{CP} \leq 24\text{ MHz}$, $V_{SS} = 0.0\text{ V}$)

($T_A = -40^\circ\text{C}$ to $+125^\circ\text{C}$, $V_{CC} = 5.0\text{ V} \pm 10\%$, $f_{CP} \leq 16\text{ MHz}$, $V_{SS} = 0.0\text{ V}$)

Parameter	Symbol	Pin	Condition	Value		Unit	Remarks
				Min	Max		
Serial clock cycle time	t_{SCYC}	SCK2, SCK3	Internal clock operation output pins are $C_L = 80\text{ pF} + 1\text{ TTL}$	$8\ t_{CP}^*$	—	ns	
SCK ↓ → SOT delay time	t_{SLOV}	SCK2, SCK3, SOT2, SOT3		-80	+80	ns	
Valid SIN → SCK ↑	t_{IVSH}	SCK2, SCK3, SIN0 to SIN4		100	—	ns	
SCK ↑ → Valid SIN hold time	t_{SHIX}	SCK2, SCK3, SIN2, SIN3		60	—	ns	
Serial clock "H" pulse width	t_{SHSL}	SCK2, SCK3	External clock operation output pins are $C_L = 80\text{ pF} + 1\text{ TTL}$	$4\ t_{CP}^*$	—	ns	
Serial clock "L" pulse width	t_{SLSH}	SCK2, SCK3		$4\ t_{CP}^*$	—	ns	
SCK ↓ → SOT delay time	t_{SLOV}	SCK2, SCK3, SOT2, SOT3		—	150	ns	
Valid SIN → SCK ↑	t_{IVSH}	SCK2, SCK3, SIN2, SIN3		60	—	ns	
SCK ↑ → Valid SIN hold time	t_{SHIX}	SCK2, SCK3, SIN2, SIN3		60	—	ns	

* : Refer to “ (1) Clock timing” rating for t_{CP} (internal operating clock cycle time).

Notes : • AC characteristic in CLK synchronized mode.

- C_L is load capacity value of pins when testing.
- t_{CP} is the machine cycle (Unit : ns)

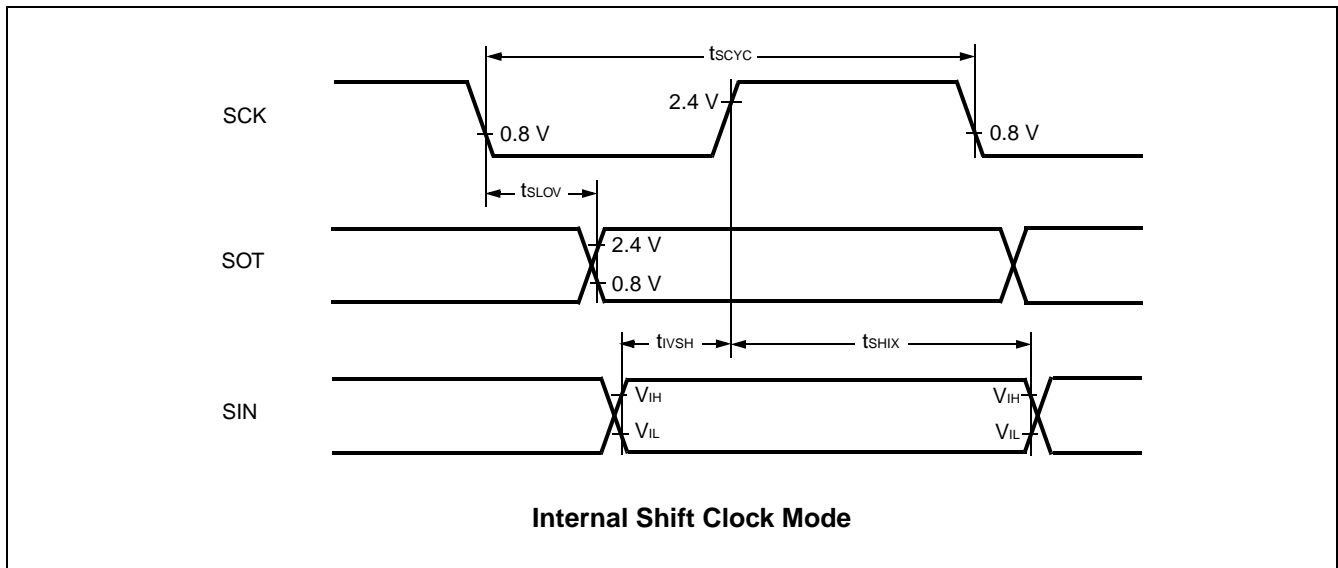

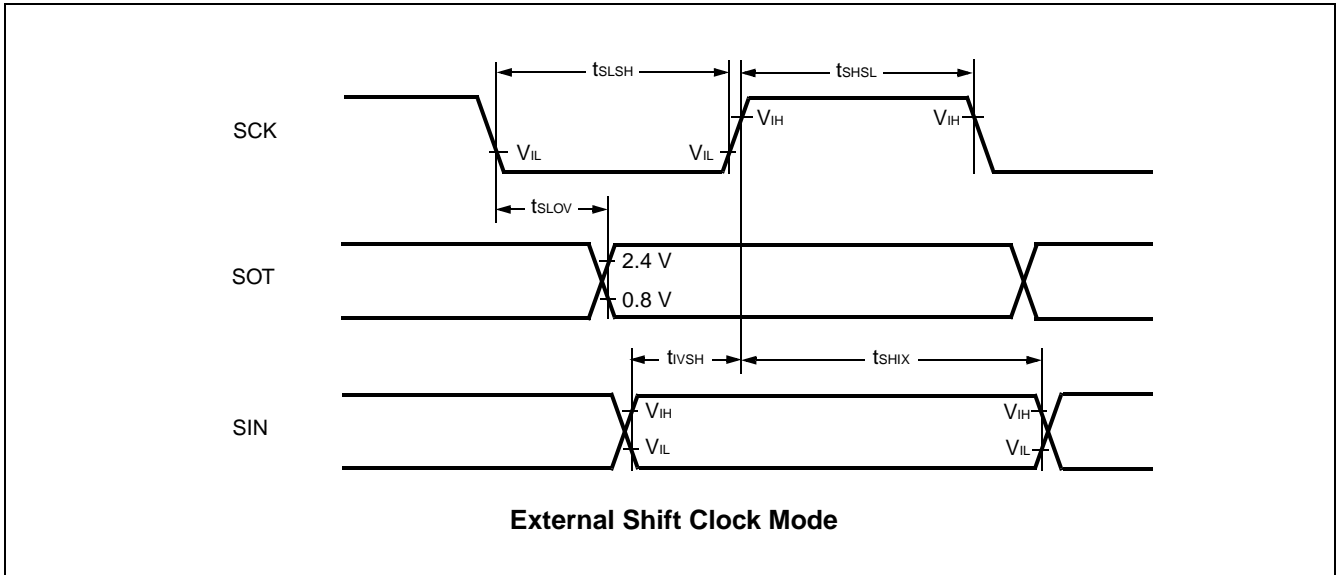

(10) Trigger Input Timing

($T_A = -40^\circ\text{C}$ to $+105^\circ\text{C}$, $V_{CC} = 5.0\text{ V} \pm 10\%$, $f_{CP} \leq 24\text{ MHz}$, $V_{SS} = 0.0\text{ V}$)

($T_A = -40^\circ\text{C}$ to $+125^\circ\text{C}$, $V_{CC} = 5.0\text{ V} \pm 10\%$, $f_{CP} \leq 16\text{ MHz}$, $V_{SS} = 0.0\text{ V}$)

Parameter	Symbol	Pin	Condition	Value		Unit	Remarks
				Min	Max		
Input pulse width	t_{TRGH} t_{TRGL}	INT8 to INT15, INT9R to INT11R, ADTG	—	$5 t_{CP}$	—	ns	

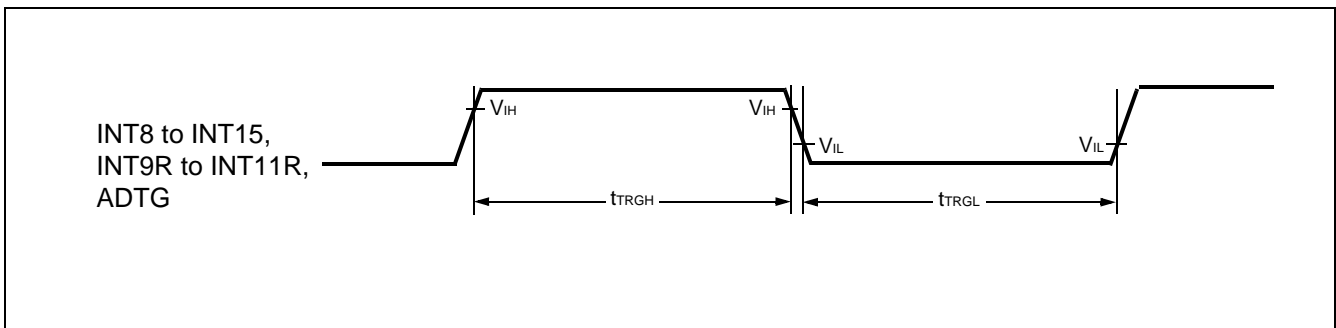

MB90350 Series

(11) Timer Related Resource Input Timing

($T_A = -40^\circ\text{C}$ to $+105^\circ\text{C}$, $V_{CC} = 5.0\text{ V} \pm 10\%$, $f_{CP} \leq 24\text{ MHz}$, $V_{SS} = 0.0\text{ V}$)

($T_A = -40^\circ\text{C}$ to $+125^\circ\text{C}$, $V_{CC} = 5.0\text{ V} \pm 10\%$, $f_{CP} \leq 16\text{ MHz}$, $V_{SS} = 0.0\text{ V}$)

Parameter	Symbol	Pin	Condition	Value		Unit	Remarks
				Min	Max		
Input pulse width	t_{TIWH}	TIN1, TIN3, IN0, IN1, IN4 to IN7	—	4 t_{CP}	—	ns	
	t_{TIWL}						

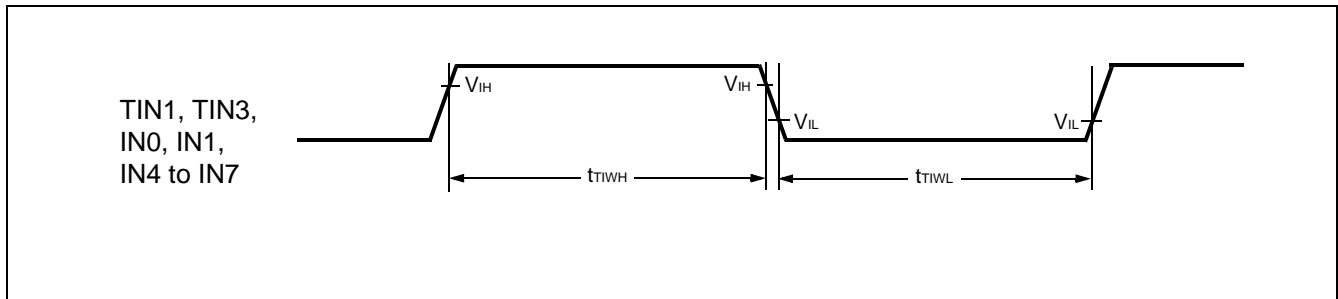

(12) Timer Related Resource Output Timing

($T_A = -40^\circ\text{C}$ to $+105^\circ\text{C}$, $V_{CC} = 5.0\text{ V} \pm 10\%$, $f_{CP} \leq 24\text{ MHz}$, $V_{SS} = 0.0\text{ V}$)

($T_A = -40^\circ\text{C}$ to $+125^\circ\text{C}$, $V_{CC} = 5.0\text{ V} \pm 10\%$, $f_{CP} \leq 16\text{ MHz}$, $V_{SS} = 0.0\text{ V}$)

Parameter	Symbol	Pin	Condition	Value		Unit	Remarks
				Min	Max		
CLK \uparrow \Rightarrow T_{OUT} change time	t_{TO}	TOT1, TOT3, PPG4, PPG6, PPG8 to PPGF	—	30	—	ns	

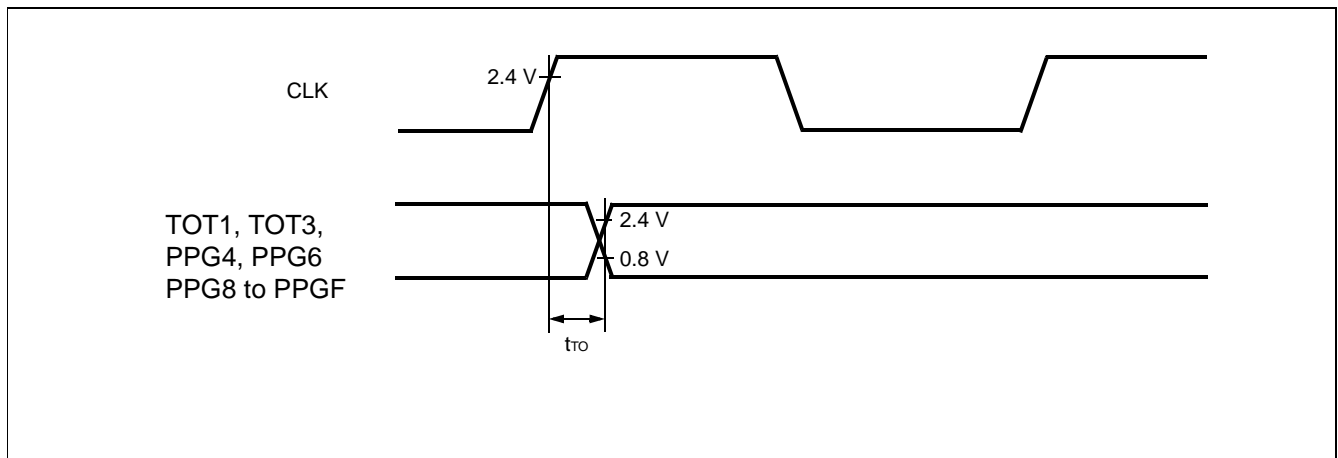

(13) I²C Timing

(T_A = -40°C to +105°C, V_{CC} = AV_{CC} = 5.0 V ± 10%, f_{CP} ≤ 24 MHz, V_{SS} = AV_{SS} = 0.0 V)

(T_A = -40°C to +125°C, V_{CC} = AV_{CC} = 5.0 V ± 10%, f_{CP} ≤ 16 MHz, V_{SS} = AV_{SS} = 0.0 V)

Parameter	Symbol	Condition	Standard-mode		Fast-mode*4		Unit
			Min	Max	Min	Max	
SCL clock frequency	f _{SCL}	R = 1.7 kΩ, C = 50 pF*1	0	100	0	400	kHz
Hold time (repeated) START condition SDA↓→SCL↓	t _{HDSTA}		4.0	—	0.6	—	μs
"L" width of the SCL clock	t _{LOW}		4.7	—	1.3	—	μs
"H" width of the SCL clock	t _{HIGH}		4.0	—	0.6	—	μs
Set-up time for a repeated START condition SCL↑→SDA↓	t _{SUSTA}		4.7	—	0.6	—	μs
Data hold time SCL↓→SDA↓↑	t _{HDDAT}		0	3.45*2	0	0.9*3	μs
Data set-up time SDA↓↑→SCL↑	t _{SUDAT}		250	—	100	—	ns
Set-up time for STOP condition SCL↑→SDA↑	t _{SUSTO}		4.0	—	0.6	—	μs
Bus free time between a STOP and START condition	t _{BUS}		4.7	—	1.3	—	μs

*1 : R, C : Pull-up resistor and load capacitor of the SCL and SDA lines.

*2 : The maximum t_{HDDAT} have only to be met if the device does not stretch the "L" width (t_{LOW}) of the SCL signal.

*3 : A Fast-mode I²C -bus device can be used in a Standard-mode I²C-bus system, but the requirement t_{SUDAT} ≥ 250 ns must then be met.

*4 : For use at over 100 kHz, set the machine clock to at least 6 MHz.

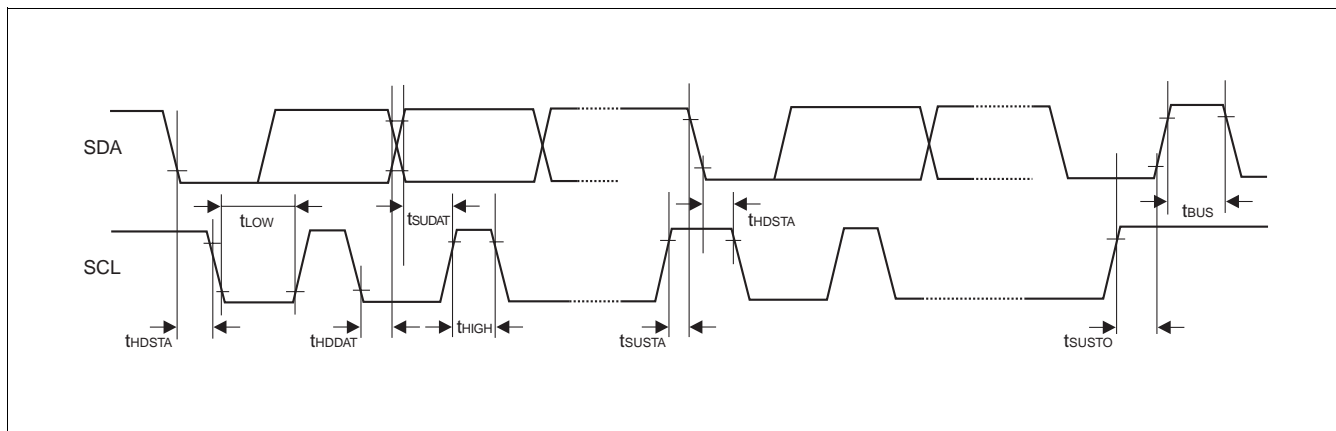

MB90350 Series

5. A/D Converter

($T_A = -40\text{ }^\circ\text{C}$ to $+105\text{ }^\circ\text{C}$, $3.0\text{ V} \leq AVRH$, $V_{CC} = AV_{CC} = 5.0\text{ V} \pm 10\%$, $f_{CP} \leq 24\text{ MHz}$, $V_{SS} = AV_{SS} = 0\text{ V}$)

($T_A = -40\text{ }^\circ\text{C}$ to $+125\text{ }^\circ\text{C}$, $3.0\text{ V} \leq AVRH$, $V_{CC} = AV_{CC} = 5.0\text{ V} \pm 10\%$, $f_{CP} \leq 16\text{ MHz}$, $V_{SS} = AV_{SS} = 0\text{ V}$)

Parameter	Symbol	Pin	Value			Unit	Remarks
			Min	Typ	Max		
Resolution	—	—	—	—	10	bit	
Total error	—	—	—	—	± 3.0	LSB	
Nonlinearity error	—	—	—	—	± 2.5	LSB	
Differential nonlinearity error	—	—	—	—	± 1.9	LSB	
Zero reading voltage	V_{OT}	AN0 to AN14	$AV_{SS} - 1.5$	$AV_{SS} + 0.5$	$AV_{SS} + 2.5$	LSB	
Full scale reading voltage	V_{FST}	AN0 to AN14	$AVRH - 3.5$	$AVRH - 1.5$	$AVRH + 0.5$	LSB	
Compare time	—	—	1.0	—	16,500	μs	$4.5\text{ V} \leq AV_{CC} \leq 5.5\text{ V}$
			2.0				$4.0\text{ V} \leq AV_{CC} < 4.5\text{ V}$
Sampling time	—	—	0.5	—	∞	μs	$4.5\text{ V} \leq AV_{CC} \leq 5.5\text{ V}$
			1.2				$4.0\text{ V} \leq AV_{CC} < 4.5\text{ V}$
Analog port input current	I_{AIN}	AN0 to AN14	-0.3	—	+0.3	μA	
Analog input voltage range	V_{AIN}	AN0 to AN14	AV_{SS}	—	$AVRH$	V	
Reference voltage range	—	$AVRH$	$AV_{SS} + 2.7$	—	AV_{CC}	V	
Power supply current	I_A	AV_{CC}	—	3.5	7.5	mA	
	I_{AH}	AV_{CC}	—	—	5	μA	*
Reference voltage current	I_R	$AVRH$	—	600	900	μA	
	I_{RH}	$AVRH$	—	—	5	μA	*
Offset between input channels	—	AN0 to AN14	—	—	4	LSB	

* : IF A/D convertor is not operating, a current when CPU is stopped is applicable ($V_{CC} = AV_{CC} = AVRH = 5.0\text{ V}$) .

Note : The accuracy gets worse as $|AVRH - AV_{SS}|$ becomes smaller.

6. Definition of A/D Converter Terms

- Resolution : Analog variation that is recognized by an A/D converter.
- Non linearity error : Deviation between a line across zero-transition line (“00 0000 0000” ← → “00 0000 0001”) and full-scale transition line (“11 1111 1110” ← → “11 1111 1111”) and actual conversion characteristics.
- Differential linearity error : Deviation of input voltage, which is required for changing output code by 1 LSB, from an ideal value.
- Total error : Difference between an actual value and an ideal value. A total error includes zero transition error, full-scale transition error, and linear error.
- Zero reading voltage : Input voltage which results in the minimum conversion value.
- Full scale reading voltage : Input voltage which results in the maximum conversion value.

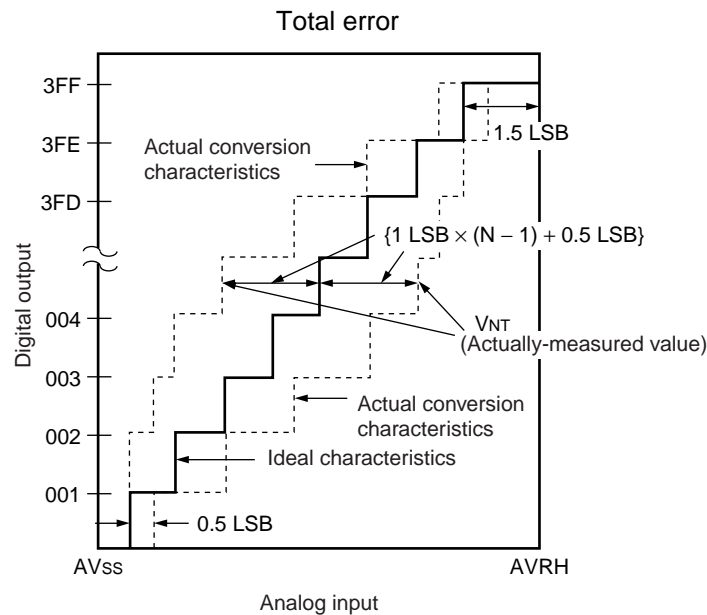

$$\text{Total error of digital output "N"} = \frac{V_{NT} - \{1 \text{ LSB} \times (N - 1) + 0.5 \text{ LSB}\}}{1 \text{ LSB}} \quad [\text{LSB}]$$

$$1 \text{ LSB} = (\text{Ideal value}) \frac{AV_{RH} - AV_{SS}}{1024} \quad [\text{V}]$$

$$V_{OT} (\text{Ideal value}) = AV_{SS} + 0.5 \text{ LSB} \quad [\text{V}]$$

$$V_{FST} (\text{Ideal value}) = AV_{RH} - 1.5 \text{ LSB} \quad [\text{V}]$$

V_{NT} : A voltage at which digital output transitions from (N - 1) to N.

(Continued)

MB90350 Series

(Continued)

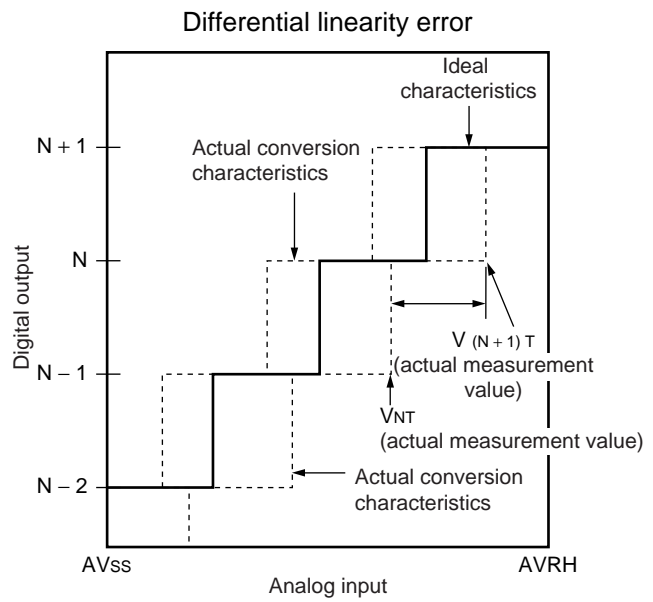
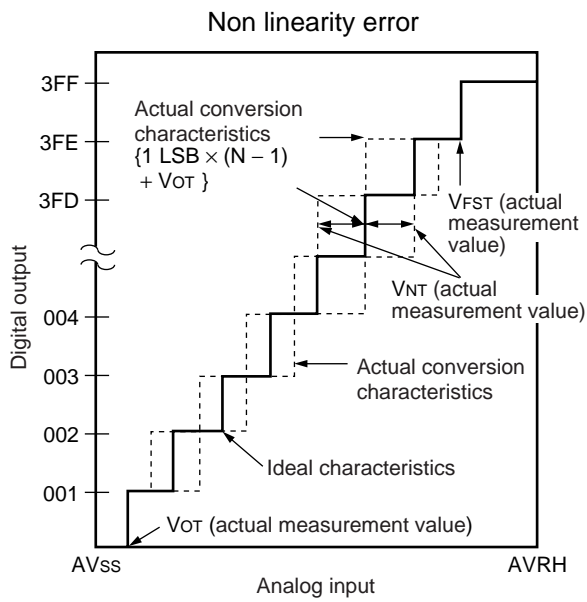

$$\text{Non linearity error of digital output } N = \frac{V_{NT} - \{1 \text{ LSB} \times (N - 1) + V_{OT}\}}{1 \text{ LSB}} \text{ [LSB]}$$

$$\text{Differential linearity error of digital output } N = \frac{V_{(N+1)T} - V_{NT}}{1 \text{ LSB}} - 1 \text{ LSB [LSB]}$$

$$1 \text{ LSB} = \frac{V_{FST} - V_{OT}}{1022} \text{ [V]}$$

V_{OT} : Voltage at which digital output transits from "000_H" to "001_H."

V_{FST} : Voltage at which digital output transits from "3FE_H" to "3FF_H."

7. Notes on A/D Converter Section

Use the device with external circuits of the following output impedance for analog inputs :

Recommended output impedance of external circuits are : Approx. 1.5 kΩ or lower ($4.0\text{ V} \leq AV_{CC} \leq 5.5\text{ V}$, sampling period $\leq 0.5\text{ }\mu\text{s}$)

If an external capacitor is used, in consideration of the effect by tap capacitance caused by external capacitors and on-chip capacitors, capacitance of the external one is recommended to be several thousand times as high as internal capacitor.

If output impedance of an external circuit is too high, a sampling period for an analog voltage may be insufficient.

• Analog input circuit model

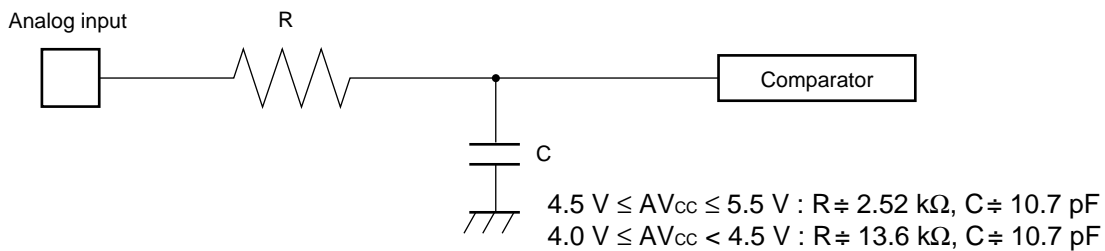

Note : Use the values in the figure only as a guideline.

8. Flash Memory Program/Erase Characteristics

Parameter	Conditions	Value			Unit	Remarks
		Min	Typ	Max		
Sector erase time	$T_A = +25\text{ }^\circ\text{C}$ $V_{CC} = 5.0\text{ V}$	—	1	15	s	Excludes programming prior to erasure
Chip erase time		—	9	—	s	Excludes programming prior to erasure
Word (16 bit width) programming time		—	16	3,600	μs	Except for the overhead time of the system
Program/Erase cycle	—	10,000	—	—	cycle	
Flash Data Retention Time	Average $T_A = +85\text{ }^\circ\text{C}$	20	—	—	Years	*

* : This value comes from the technology qualification.

(Using Arrhenius equation to translate high temperature measurements into normalized value at $+85\text{ }^\circ\text{C}$)

MB90350 Series

■ ORDERING INFORMATION

Part number	Package	Remarks
MB90F352PFM	64-pin Plastic LQFP (FPT-64P-M09)	
MB90F352SPFM		
MB90352PFM	64-pin Plastic LQFP (FPT-64P-M09)	
MB90352SPFM		
MB90V340A-101	299-pin Ceramic PGA (PGA-299C-A01)	For evaluation
MB90V340A-102		

PACKAGE DIMENSIONS

64-pin Plastic LQFP
(FPT-64P-M09)

Note 1) * : These dimensions do not include resin protrusion.
 Note 2) Pins width and pins thickness including plating thickness.
 Note 3) Pins width do not include tie bar cutting remainder.

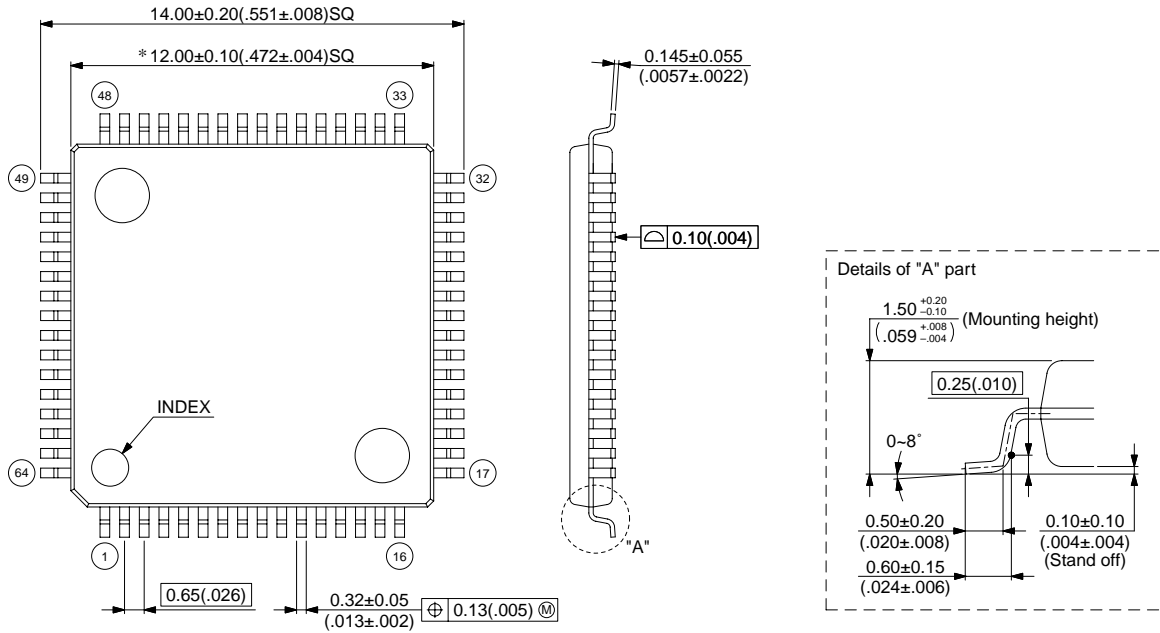

© 2003 FUJITSU LIMITED F64018S-c-3-5

Dimensions in mm (inches)

Note : The values in parentheses are reference values.

FUJITSU LIMITED

All Rights Reserved.

The contents of this document are subject to change without notice. Customers are advised to consult with FUJITSU sales representatives before ordering.

The information, such as descriptions of function and application circuit examples, in this document are presented solely for the purpose of reference to show examples of operations and uses of Fujitsu semiconductor device; Fujitsu does not warrant proper operation of the device with respect to use based on such information. When you develop equipment incorporating the device based on such information, you must assume any responsibility arising out of such use of the information. Fujitsu assumes no liability for any damages whatsoever arising out of the use of the information.

Any information in this document, including descriptions of function and schematic diagrams, shall not be construed as license of the use or exercise of any intellectual property right, such as patent right or copyright, or any other right of Fujitsu or any third party or does Fujitsu warrant non-infringement of any third-party's intellectual property right or other right by using such information. Fujitsu assumes no liability for any infringement of the intellectual property rights or other rights of third parties which would result from the use of information contained herein.

The products described in this document are designed, developed and manufactured as contemplated for general use, including without limitation, ordinary industrial use, general office use, personal use, and household use, but are not designed, developed and manufactured as contemplated (1) for use accompanying fatal risks or dangers that, unless extremely high safety is secured, could have a serious effect to the public, and could lead directly to death, personal injury, severe physical damage or other loss (i.e., nuclear reaction control in nuclear facility, aircraft flight control, air traffic control, mass transport control, medical life support system, missile launch control in weapon system), or (2) for use requiring extremely high reliability (i.e., submersible repeater and artificial satellite).

Please note that Fujitsu will not be liable against you and/or any third party for any claims or damages arising in connection with above-mentioned uses of the products.

Any semiconductor devices have an inherent chance of failure. You must protect against injury, damage or loss from such failures by incorporating safety design measures into your facility and equipment such as redundancy, fire protection, and prevention of over-current levels and other abnormal operating conditions.

If any products described in this document represent goods or technologies subject to certain restrictions on export under the Foreign Exchange and Foreign Trade Law of Japan, the prior authorization by Japanese government will be required for export of those products from Japan.