

---

**SGS-THOMSON SYSTEMS FOR  
RECHARGEABLE BATTERIES**

---

**1 - FOREWORD**

In casual language a battery pack is anything that supplies electrical power through a chemical reaction whose description is beyond the scope of this note and it is normally built by a combination (series, parallel, or both) of cells that are the basic electrochemical building blocks.

In the following a battery pack will be simply named battery.

Batteries can be grouped into two distinct categories:

- Disposable Primary Batteries
- Rechargeable Secondary Batteries

This note deals with the SGS-THOMSON systems for rechargeable batteries but it is worth to mention some typical characteristics of primary batteries too.

**Primary batteries**

The variety of types, based on different chemistries, is very high (for lithium batteries alone there are more than 30 different types).

However these types of batteries share some common characteristics:

- Primary batteries offer significantly higher energy density, i.e. for a given volume more watts per hour are available when compared with secondary batteries.
- Primary batteries offer a lower self-discharge rate
- Primary batteries are less expensive than secondary
- Primary batteries have higher internal impedance so that they have less current sourcing capability.
- Thanks to standardization, replacement is easy world wide.

**Secondary batteries**

Despite the advantages mentioned above, there is a growing demand on secondary batteries because of:

- Increased electrical power drain of portable equipment that would exhaust very rapidly the energy stored into a primary battery.

- Increased sensitivity to the environment protection: primary batteries must be disposed of and they contain materials that are hazardous for the environment.

Some types of rechargeable batteries contains hazardous materials too but they exhibit a much longer usable life so that one secondary battery can replace more than 500 disposable batteries.

The most popular secondary batteries can be divided into three major groups:

- Lead-acid
- Nickel-cadmium
- Nickel-Metal hydride

A fourth technology, Lithium-Ion, is now reaching the market even if the number of manufacturers as well as the volumes are still limited. This new technology is quite promising because it will offer a significant leap in energy density.

The table 1 shows some typical values for primary and secondary batteries that, however, can vary with manufacturer and battery size.

SGS-THOMSON have developed various families of products for the specific application in the field of secondary batteries. These families are briefly described in the data book. It must be noted that the large variety of:

- battery types and sizes.
- available energy source (mains or car batteries).
- connections to the final sets where batteries are employed.
- etc.

does not allow an appropriate product standardization. Therefore the following descriptions deal mainly with the basic principles of SGS-THOMSON products.

For specific application, please contact the local SGS-THOMSON organization or the Division Product Marketing:

**SUBSYSTEMS PRODUCTS GROUP  
SGS-THOMSON MICROELECTRONICS  
20041 AGRATE BRIANZA - ITALY  
CENTRO DIREZIONALE COLLEONI  
PALAZZO ANDROMEDA, 3  
Tel: 0039-39-635574 Fax: 0039-39-635582**

## ST systems for rechargeable batteries

Table 1: Typical battery performance at 20 °C

Type : PRIMARY	Nominal Voltage	Energy Density Wh / Kg
Alkaline - MnO <sub>2</sub>	1.4	130
Carbon - Zinc	1.3	65
Lithium - MnO <sub>2</sub>	2.7	230
Mercury - Zinc	1.3	110
Silver - Oxide *	1.5	130
Zinc - Air *	1.3	300
Type : SECONDARY		
Lead - Acid	2	35
Nickel - Cadmium	1.2	35
Nickel - Metal Hydride	1.2	55
Lithium - Ion	3.6	130

\* For button cells

### 2 - BATTERY ELIMINATORS

Whenever another power source is available, it may be convenient to preserve the battery by providing an alternate method to deliver the power required by the electronic equipment.

In this case the battery is replaced by a battery eliminator that is, essentially, a constant voltage

regulator. As typical example, a battery eliminator can be used to supply a handheld phone from a car battery thus avoiding the use of the phone battery during travels.

For replacement of a 5/6 cell battery pack, the GS-R28.0BE switch mode battery eliminator can be used. See the corresponding data sheet.

Figure 1. Output characteristics of GS-R28.0BE  
Peak current duration: 0,6 ms with 0,13 duty cycle

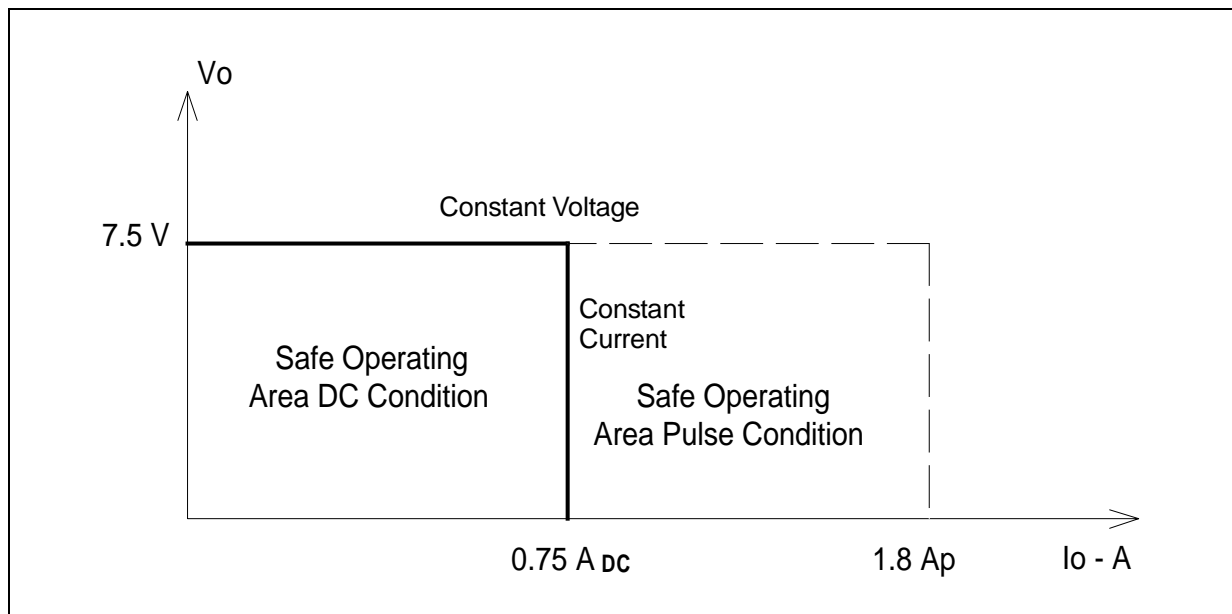

### 3. BATTERY SAVERS

While a battery eliminator replaces completely the battery pack, a battery saver is used together with the battery pack. The battery is charged in a float

mode and it is maintained in a ready-to-serve condition.

The principle is shown in fig. 2

Figure 2. Battery Saver

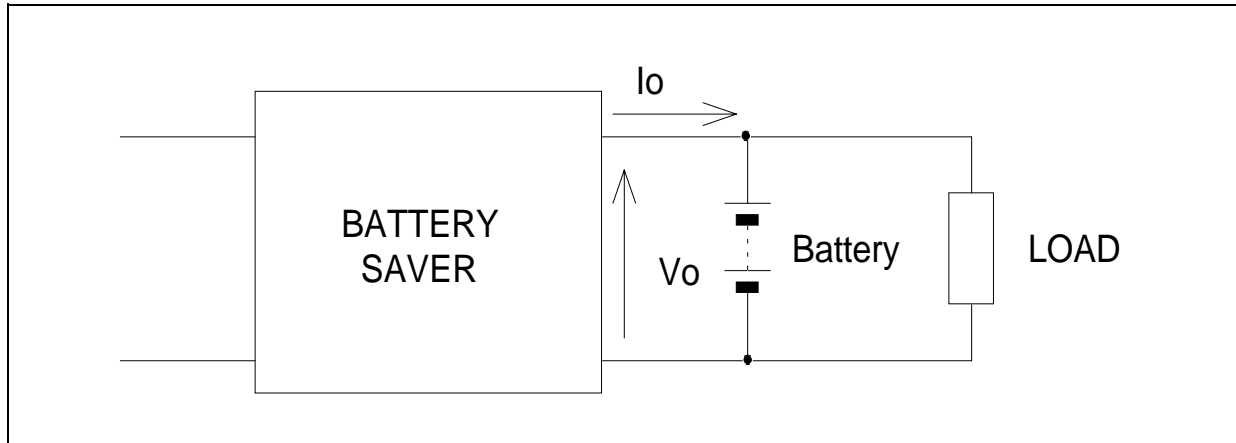

Figure 3.

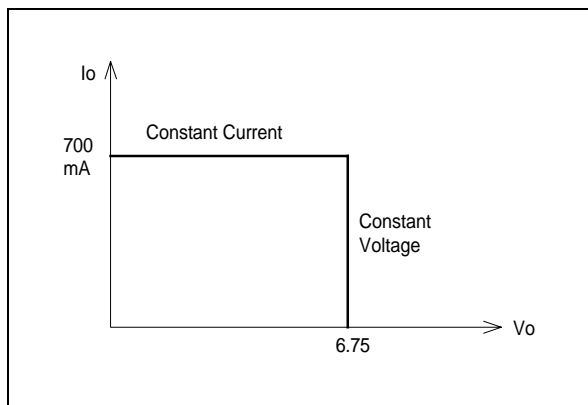
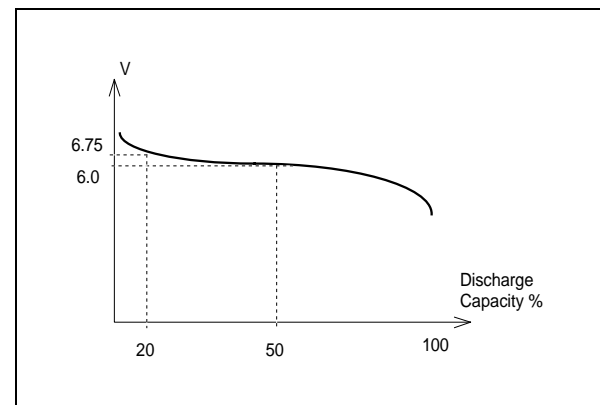

Figure 4.



The output electrical characteristics of a battery saver is shown in fig. 3.

The indicated values are relevant to a 5 cell battery pack.

If the initial battery voltage is greater than 6.75V, the battery will supply the load and no current is delivered by the battery saver. Therefore the battery is discharged by the load until its voltage reaches 6.75 V. At this point, the battery saver, working in a voltage mode (vertical line of the characteristic of fig. 3), supplies the current required by the load and the battery can save its stored energy. After removal of the battery saver, the battery is still retaining more than 80 % of its capacity (for a 5 cell battery, 50 % of capacity correspond to about  $5 \times 1,2 = 6.0$  V as shown on the discharge curve of fig. 4).

If the initial battery voltage is lower than the preset value of 6.75 V, the battery saver works in constant current mode (horizontal line of the characteristics of fig. 3) by delivering a constant current of 700 mA that charges the battery to about 80 % of its capacity until the battery voltage reaches 6.75 V. Clearly if the load is ON, just the net difference between 700 mA and the load current is available to charge the battery. As a typical example, a battery saver can be used to supply a handheld phone from a car battery thus providing the current needed by the phone and maintaining, in the mean time, about 80% of the battery capacity.

For utilization together with a 5 cell battery pack, the GSCC-7.007BS switch mode battery saver can be used. See the corresponding data sheet.

### 4. BATTERY CHARGERS

The SGS-THOMSON battery chargers are high-quality systems particularly designed to charge NiCd and NiMH batteries (for Lead-Acid and Lithium-Ion batteries, please consult SGS-THOMSON).

Proper charging is a key to success with any battery application since improper charging methodology can be detrimental to the battery life. Depending on the accuracy of this charging methodology, a NiCd or a NiMH battery can withstand more than 500 recharging cycles (typically 1000 cycles) before being disposed off.

The basic charging process consists in returning to the battery the electrons that were delivered during the discharge.

In all the SGS-THOMSON battery chargers, the electrons are returned as a constant DC current of proper polarity and magnitude.

While it could be desirable to reduce the time to completely recharge a battery by increasing the magnitude of the charging DC current, it must be clearly understood that the maximum charge rate is normally specified by the manufacturer for every specific battery type.

Four different charge rates (expressed in terms of C) are defined in industry as shown in the Table 1.

METHOD OF CHARGING	CHARGE RATE
Trickle	0.01 C to 0.02 C
Standard	0.05 C to 0.1 C
Quick	0.2 C to 0.33 C
Fast & Ultra Fast	1 C to 4 C

The C rate is the charging current in Amperes numerically equivalent to the capacity given in Ah. For example, a battery with a capacity C=1.2 Ah is charged at 1C if the charging current is 1,2 A.

The variety of different battery types (standard, quick, fast and each one with a different capacity C), the variety of available energy for charge (DC or AC), the variety of mechanical constraints and the variety of economical considerations do not allow the conception of a unique, universal and economic battery charger to be used under all the circumstances.

Therefore SGS-THOMSON has developed a product strategy by a differentiated approach specific for each type of battery pack and for each customer. However SGS-THOMSON battery chargers share some common features as outlined in the following:

- fast charge by a constant current to allow a perfect control of the current level.

- constant current generation by a switch mode approach to allow very high efficiency i.e. reduction of power dissipation and waste.
- constant monitoring of charge status by microprocessors to allow the shortest charging time without reaching hazardous conditions of overcharge and so ensuring several hundreds recharge cycles.
- common software algorithm for NiCd and NiMH batteries to allow freedom to the user in the adoption of battery types.
- continuous display of charge status by LEDs driven directly by microprocessors.
- back up protection by timers to stop the fast charge even under anomalous conditions.
- possibility to use the electronic system even when its battery is under charge.
- stop of fast charge when the battery temperature is outside the allowed range ( $T_{batt} < 0^{\circ}\text{C}$  or  $T_{batt} > 50^{\circ}\text{C}$ )
- charging current level adjusted according to the battery temperature (trickle mode is imposed if  $0^{\circ} < T_{batt} < 10^{\circ}\text{C}$  or  $40^{\circ}\text{C} < T_{batt} < 50^{\circ}\text{C}$ ).
- sensing of the battery presence (if the battery is not connected to the charger, the output voltage of the charger is automatically switched off).
- sensing of one or more default cells inside the battery pack (if this condition occurs the charger is switched off and the condition is signaled by LED status).
- sensing of the maximum battery voltage to stop the charge in case of anomalous conditions
- initial trickle charge followed by fast charge in case of deeply discharged batteries
- minimum current drain (less than 100  $\mu\text{A}$ ) in case the charger is left connected to the battery even when it is not used.

The a.m. features are performed by continuous monitoring of battery absolute voltage and battery voltage variation in time, of battery absolute temperature and battery temperature variation in time, of elapsed time.

Depending on the type of available power source and on the application, the SGS- THOMSON battery chargers can be grouped into four different categories:

- in-car battery chargers (cigar lighter types): **GSCC-8.507BC**
- wall-mount battery chargers (for mains plug) : **GSAC-8.507AC**
- desk top battery chargers
- in car battery chargers with hands free operation (cradle types).

**4.1 IN-CAR BATTERY CHARGERS (GSCC-8.507BC).**

These chargers can be used in a car when the battery pack consists of no more than 6 cells (either NiCd or NiMH).

They are assembled into a cigar lighter package as shown in fig 5.

**Figure 5.**

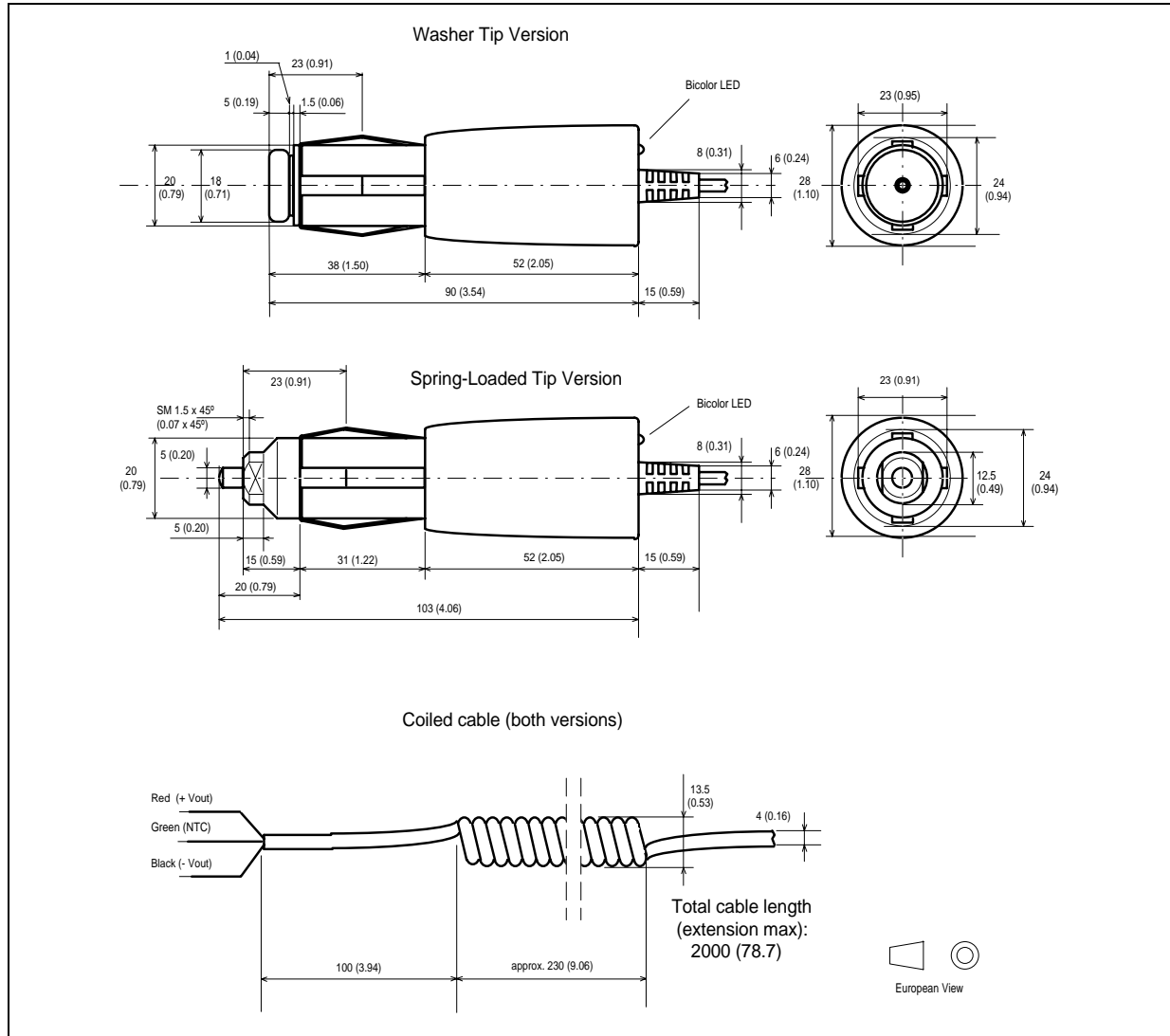

The package has been particularly designed to avoid mechanical interferences with other mechanical part of a car when the charger is inserted into the car cigar lighter plug.

All the used materials are non flammable and UL recognized.

A dual color LED is used to display different charge status or anomalous battery conditions by continuous or flashing green and red colors or both off so that five different messages can be sent to the user. ST can assist the customer in assigning the proper

color (green or red) and condition (continuous or flashing or off) according to different battery status. For optimum charger performance, customers should specify the NTC type. These cigar lighter types retain all the feature common to ST battery chargers.

This charger can deliver a maxim charge current of 1A. The actual value depends on the battery charge status and temperature. Trickle charge is normally 5% of the maximum fast charge current.



**4.3 DESKTOP BATTERY CHARGERS FOR HANDHELD PHONES.**

SGS-THOMSON design and manufacture many types of desktop battery chargers for handheld phones application. These chargers are designed under contracts for specific customers because no standardization exists for this type of application.

These contracts are covered by NON DISCLOSURE AGREEMENTS so that no mechanical information can be provided.

Nevertheless the following information can be provided here.

Mechanically the Desk top chargers are divided into two groups:

- Single slot desk top chargers. The phone is inserted inside this slot. Electrically the phone may be in OFF status, stand by or receiving mode. If the status of the phone is available on one or more phone pins, the desk top charger can accommodate the charging current to supply the additional current requested by the phone without affecting the charging time for the battery.

Upon request ST can provide an additional feature to allow the charge of the battery and an additional power supply for the phone regardless of its status (OFF, stand-by, receiving or transmitting mode). ST Patent.

- Dual slot desk top chargers. In these type of chargers the front slot is normally used to charge the battery that is directly connected to the phone while the rear slots is used to charge a spare battery pack.

ST can offer versions for simultaneous charging of the two battery packs or for sequential charging: in this last case the charging priority is assigned to the front slot.

In all the cases, ST use separate current generation and overcharge detection by microprocessors for each slot.

The ST Desk Top chargers are normally powered by an external power supply: depending on the total power available by this external supply, the simultaneous or sequential charge can be adopted.

For simultaneous charge with a maximum current of 1 A per slot, ST can provide the relevant external off line power supply.

Alternatively ST may consider the inclusion of an AC-DC switch mode power supply inside the Desk top charger.

As said previously, ST can deliver an AC-DC off-line power supply to be used in combination with dual or single slot desk top chargers.

This off-line power supply is assembled into a wall mount package. See GS20AC-12 data sheet.

**DESK TOP CHARGERS (SINGLE OR DUAL SLOT)**

**ELECTRICAL CHARACTERISTICS (Tamb=25°C unless otherwise specified)**

Symbol	Parameter	Test Conditions	Min	Typ	Max	Unit	Note
V <sub>i</sub>	Input Voltage	V <sub>o</sub> = 0 to max I <sub>o</sub> = 0 to max	12		22	V	1
V <sub>o</sub>	Output Voltage	Determined by number of cells	0		9.8	V	2
I <sub>o</sub>	Output Current per slot	V <sub>i</sub> = 12 to 22 V	0		1	A	3
η	Efficiency	V <sub>i</sub> = 12 V I <sub>o</sub> = 0.7 A per slot		75		%	
f <sub>s</sub>	Switching frequency	V <sub>i</sub> = 12 V to 22 V any value for V <sub>o</sub> and I <sub>o</sub>		100		kHz	4
T <sub>op</sub>	Operating Ambient Temperature		0		35	°C	

Note 1: The wide input voltage range allows the use of an unregulated external power supply.

Note 2: The output voltage depends on the number of cells in the battery pack and on the battery charge status. The reported maximum value is for a 6 cell battery pack.

Note 3: The reported value (1 A) is the maximum charging current for a battery pack of 6 cell. For a higher number of cells, the max charging current must be scaled down accordingly. The real value of fast charge current depends on the actual type of battery. Trickle charge current is normally 5% of the maximum fast charge current.

Note 4: For the dual slot version, the switching frequency is synchronized for the two slots to avoid frequency beats and interference.

## ST systems for rechargeable batteries

---

### 4.4 IN CAR BATTERY CHARGERS WITH HANDS FREE OPERATION FOR HAND HELD PHONES (CRADLE TYPES).

SGS-THOMSON design and manufacture cradle type battery chargers for in car hands free operation.

These products are so peculiar in their application (battery charge is just one of the several function performed) that no general description can be provided here.

Nevertheless it is worth to mention that the battery charge is performed along the same feature already described.

Even if ST use a switch mode approach for constant current generation, no interference is induced on the phone (radiated or conducted noise).

### 5. CONCLUSION

The range of ST products devoted to battery charge is very broad and each product is designed specifically according to customer requests.

This note is intended as a general description of these products to outlight some specific (and in many case unique) feature of ST chargers.

In this domain, the best results are obtained by a close cooperation between ST and the customers and ST is available to customize any type of application for any type of battery.

Information furnished is believed to be accurate and reliable. However, SGS-THOMSON Microelectronics assumes no responsibility for the consequences of use of such information nor for any infringement of patents or other rights of third parties which may result from its use. No license is granted by implication or otherwise under any patent or patent rights of SGS-THOMSON Microelectronics. Specification mentioned in this publication are subject to change without notice. This publication supersedes and replaces all information previously supplied. SGS-THOMSON Microelectronics products are not authorized for use as critical components in life support devices or systems without express written approval of SGS-THOMSON Microelectronics.

© 1994 SGS-THOMSON Microelectronics – All Rights Reserved

SGS-THOMSON Microelectronics GROUP OF COMPANIES

Australia - Brazil - China - France - Germany - Hong Kong - Italy - Japan - Korea - Malaysia - Malta - Morocco - The Netherlands - Singapore - Spain - Sweden - Switzerland - Taiwan - Thailand - United Kingdom - U.S.A.