

TJA1055

Enhanced fault-tolerant CAN transceiver

Rev. 02 — 30 October 2006

Preliminary data sheet

1. General description

The TJA1055 is the interface between the protocol controller and the physical bus wires in a Controller Area Network (CAN). It is primarily intended for low-speed applications up to 125 kBd in passenger cars. The device provides differential receive and transmit capability but will switch to single-wire transmitter and/or receiver in error conditions. The TJA1055 is the enhanced version of the TJA1054 and TJA1054A. TJA1055 has the same functionality but in addition offering a number of improvements. The most important improvements of the TJA1055 with respect to the TJA1054 and TJA1054A are:

- Improved ElectroStatic Discharge (ESD) performance
- Lower current consumption in sleep mode
- Wake-up signalling on RXD and $\overline{\text{ERR}}$ without V_{CC} active
- 3 V interfacing with microcontroller possible with TJA1055T/3

2. Features

2.1 Optimized for in-car low-speed communication

- Pin-to-pin compatible with TJA1054 and TJA1054A
- Baud rate up to 125 kBd
- Up to 32 nodes can be connected
- Supports unshielded bus wires
- Very low ElectroMagnetic Emission (EME) due to built-in slope control function and a very good matching of the CANL and CANH bus outputs
- Very high ElectroMagnetic Immunity (EMI) in normal operating mode and in low power modes
- Fully integrated receiver filters
- Transmit Data (TxD) dominant time-out function
- High ESD robustness
 - ◆ ± 8 kV Electrostatic Discharge (ESD) protection Human Body Model (HBM) for off-board pins
 - ◆ ± 6 kV Electrostatic Discharge (ESD) protection IEC 61000-4-2 for off-board pins
- Low-voltage microcontroller support

2.2 Bus failure management

- Supports single-wire transmission modes with ground offset voltages up to 1.5 V
- Automatic switching to single-wire mode in the event of bus failures, even when the CANH bus wire is short-circuited to V_{CC}

- Automatic reset to differential mode if bus failure is removed
- Full wake-up capability during failure modes

2.3 Protections

- Bus pins short-circuit safe to battery and to ground
- Thermally protected
- Bus lines protected against transients in an automotive environment
- An unpowered node does not disturb the bus lines
- Microcontroller interface without reverse current paths, if unpowered

2.4 Support for low power modes

- Low current sleep mode and standby mode with wake-up via the bus lines
- Power-on reset flag on the output

3. Quick reference data

Table 1. Quick reference data

Symbol	Parameter	Conditions	Min	Typ	Max	Unit
V_{CC}	supply voltage		4.75	-	5.25	V
V_{BAT}	battery supply voltage	no time limit	-0.3	-	+40	V
		operating mode	5.0	-	40	V
		load dump	-	-	58	V
I_{BAT}	battery supply current	sleep mode; $V_{CC} = 0$ V; $V_{BAT} = 14$ V	-	25	<td>	μ A
V_{CANH}	voltage on pin CANH	$V_{CC} = 0$ V to 5.0 V; $V_{BAT} \geq 0$ V; no time limit; with respect to any other pin	-58	-	+58	V
V_{CANL}	voltage on pin CANL	$V_{CC} = 0$ V to 5.0 V; $V_{BAT} \geq 0$ V; no time limit; with respect to any other pin	-58	-	+58	V
ΔV_{CANH}	voltage drop on pin CANH	$I_{CANH} = -40$ mA	-	-	1.4	V
ΔV_{CANL}	voltage drop on pin CANL	$I_{CANL} = 40$ mA	-	-	1.4	V
$t_{PD(L)}$	propagation delay TXD (LOW) to RXD (LOW)		-	1	-	μ s
T_{vj}	virtual junction temperature		-40	-	+150	$^{\circ}$ C

4. Ordering information

Table 2. Ordering information

Type number	Package		Version
	Name	Description	
TJA1055T	SO14	plastic small outline package; 14 leads; body width 3.9 mm	SOT108-1
TJA1055T/3	SO14	plastic small outline package; 14 leads; body width 3.9 mm	SOT108-1
TJA1055U	-	bare die; <td> × <td> × <td> μm	-

5. Block diagram

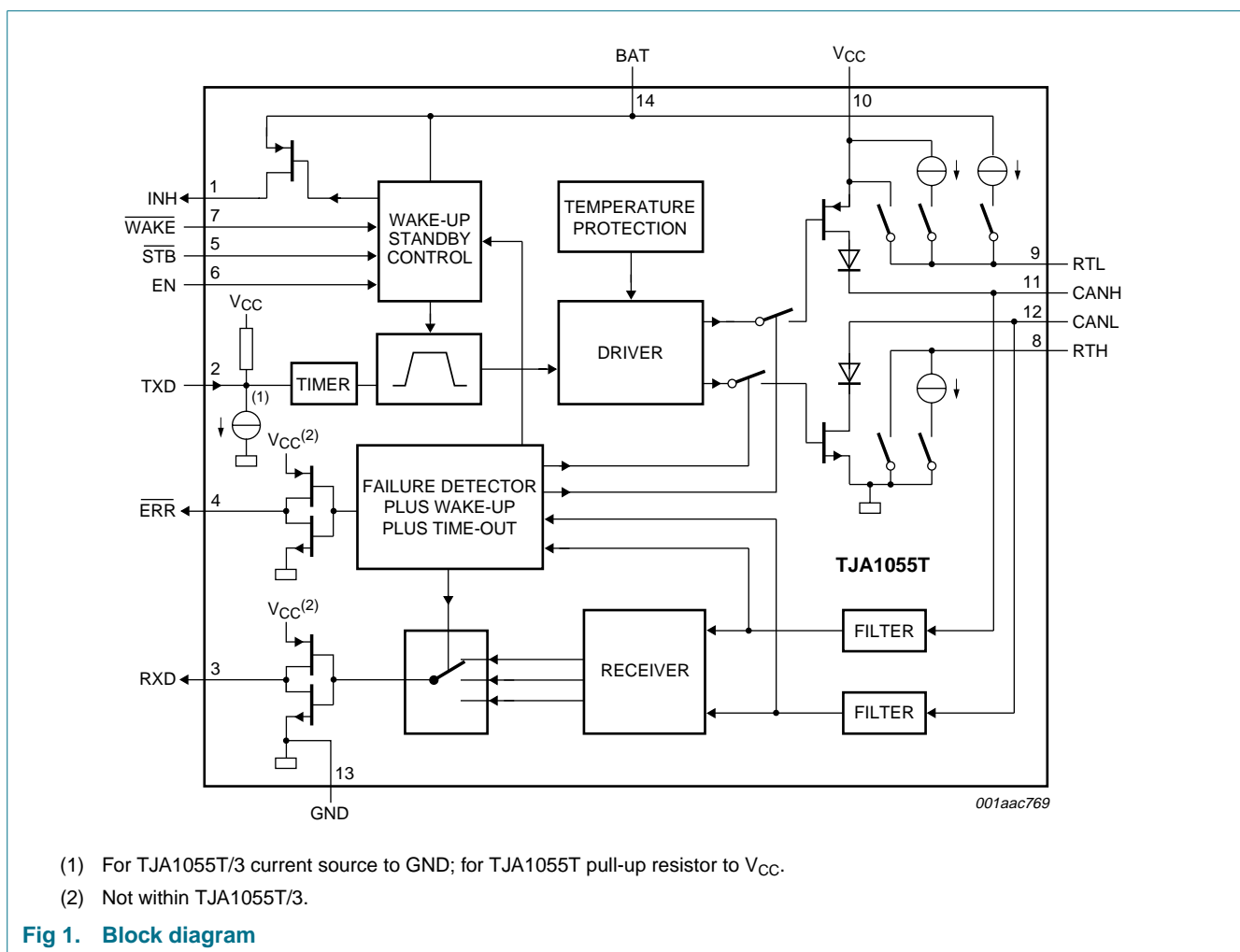

6. Pinning information

6.1 Pinning

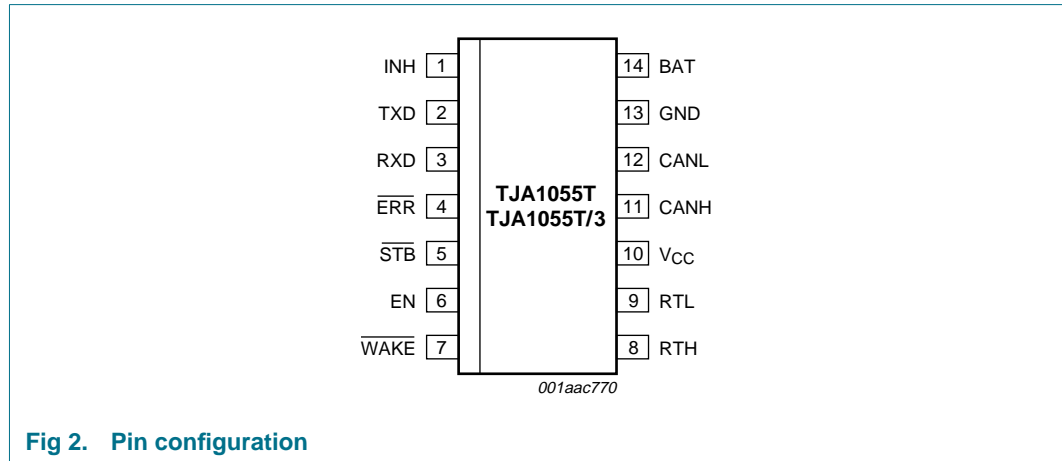

Fig 2. Pin configuration

6.2 Pin description

Table 3. Pin description

Symbol	Pin	Description
INH	1	inhibit output for switching an external voltage regulator if a wake-up signal occurs
TXD	2	transmit data input for activating the driver to the bus lines
RXD	3	receive data output for reading out the data from the bus lines
$\overline{\text{ERR}}$	4	error, wake-up and power-on indication output; active LOW in normal operating mode when a bus failure is detected; active LOW in standby and sleep mode when a wake-up is detected; active LOW in power-on standby when a V_{BAT} power-on event is detected
$\overline{\text{STB}}$	5	standby digital control signal input; together with the input signal on pin EN this input determines the state of the transceiver; see Table 5 and Figure 3
EN	6	enable digital control signal input; together with the input signal on pin STB this input determines the state of the transceiver; see Table 5 and Figure 3
$\overline{\text{WAKE}}$	7	local wake-up signal input (active LOW); both falling and rising edges are detected
RTH	8	termination resistor connection; in case of a CANH bus wire error the line is terminated with a predefined impedance
RTL	9	termination resistor connection; in case of a CANL bus wire error the line is terminated with a predefined impedance
V_{CC}	10	supply voltage
CANH	11	HIGH-level CAN bus line
CANL	12	LOW-level CAN bus line
GND	13	ground
BAT	14	battery supply voltage

7. Functional description

The TJA1055 is the interface between the CAN protocol controller and the physical wires of the CAN bus (see [Figure 9](#) and [Figure 10](#)). It is primarily intended for low-speed applications, up to 125 kBd, in passenger cars. The device provides differential transmit capability to the CAN bus and differential receive capability to the CAN controller.

To reduce EME, the rise and fall slopes are limited. This allows the use of an unshielded twisted pair or a parallel pair of wires for the bus lines. Moreover, the device supports transmission capability on either bus line if one of the wires is corrupted. The failure detection logic automatically selects a suitable transmission mode.

In normal operating mode (no wiring failures) the differential receiver is output on pin RXD (see [Figure 1](#)). The differential receiver inputs are connected to pins CANH and CANL through integrated filters. The filtered input signals are also used for the single-wire receivers. The receivers connected to pins CANH and CANL have threshold voltages that ensure a maximum noise margin in single-wire mode.

A timer function (TxD dominant time-out function) has been integrated to prevent the bus lines from being driven into a permanent dominant state (thus blocking the entire network communication) due to a situation in which pin TXD is permanently forced to a LOW level, caused by a hardware and/or software application failure.

If the duration of the LOW level on pin TXD exceeds a certain time, the transmitter will be disabled. The timer will be reset by a HIGH level on pin TXD.

7.1 Failure detector

The failure detector is fully active in the normal operating mode. After the detection of a single bus failure the detector switches to the appropriate mode (see [Table 4](#)). The differential receiver threshold voltage is set at -3.2 V typical ($V_{CC} = 5$ V). This ensures correct reception with a noise margin as high as possible in the normal operating mode and in the event of failures 1, 2, 5 and 6a. These failures, or recovery from them, do not destroy ongoing transmissions. The output drivers remain active, the termination does not change and the receiver remains in differential mode (see [Table 4](#)).

Failures 3, 3a and 6 are detected by comparators connected to the CANH and CANL bus lines. Failures 3 and 3a are detected in a two-step approach. If the CANH bus line exceeds a certain voltage level, the differential comparator signals a continuous dominant condition. Because of inter operability reasons with the predecessor products TJA1054 and TJA1054A, after a first time-out the transceiver switches to single-wire operation through CANH. If the CANH bus line is still exceeding the CANH detection voltage for a second time-out, the TJA1055 switches to CANL operation; the CANH driver is switched off and the RTH bias changes to the pull-down current source. The time-outs (delays) are needed to avoid false triggering by external RF fields.

Table 4. Bus failures

Failure	Description	Termination CANH (RTH)	Termination CANL (RTL)	CANH driver	CANL driver	Receiver mode
1	CANH wire interrupted	on	on	on	on	differential
2	CANL wire interrupted	on	on	on	on	differential
3	CANH short-circuited to battery	weak ^[1]	on	off	on	CANL
3a	CANH short-circuited to V _{CC}	weak ^[1]	on	off	on	CANL
4	CANL short-circuited to ground	on	weak ^[2]	on	off	CANH
5	CANH short-circuited to ground	on	on	on	on	differential
6	CANL short-circuited to battery	on	weak ^[2]	on	off	CANH
6a	CANL short-circuited to V _{CC}	on	on	on	on	differential
7	CANL and CANH mutually short-circuited	on	weak ^[2]	on	off	CANH

[1] A weak termination implies a pull-down current source behavior of 75 μ A typical.

[2] A weak termination implies a pull-up current source behavior of 75 μ A typical.

Failure 6 is detected if the CANL bus line exceeds its comparator threshold for a certain period of time. This delay is needed to avoid false triggering by external RF fields. After detection of failure 6, the reception is switched to the single-wire mode through CANH; the CANL driver is switched off and the RTL bias changes to the pull-up current source.

Recovery from failures 3, 3a and 6 is detected automatically after reading a consecutive recessive level by corresponding comparators for a certain period of time.

Failures 4 and 7 initially result in a permanent dominant level on pin RXD. After a time-out the CANL driver is switched off and the RTL bias changes to the pull-up current source. Reception continues by switching to the single-wire mode via pins CANH or CANL. When failures 4 or 7 are removed, the recessive bus levels are restored. If the differential voltage remains below the recessive threshold level for a certain period of time, reception and transmission switch back to the differential mode.

If any of the wiring failure occurs, the output signal on pin $\overline{\text{ERR}}$ will be set to LOW. On error recovery, the output signal on pin $\overline{\text{ERR}}$ will be set to HIGH again. In case of an interrupted open bus wire, this failure will be detected and signalled only if there is an open wire between the transmitting and receiving node(s). Thus, during open wire failures, pin $\overline{\text{ERR}}$ typically toggles.

During all single-wire transmissions, EMC performance (both immunity and emission) is worse than in the differential mode. The integrated receiver filters suppress any HF noise induced into the bus wires. The cut-off frequency of these filters is a compromise between propagation delay and HF suppression. In single-wire mode, LF noise cannot be distinguished from the required signal.

7.2 Low power modes

The transceiver provides three low power modes which can be entered and exited via $\overline{\text{STB}}$ and EN (see [Table 5](#) and [Figure 3](#)).

The sleep mode is the mode with the lowest power consumption. Pin INH is switched to HIGH-impedance for deactivation of the external voltage regulator. Pin CANL is biased to the battery voltage via pin RTL. Pins RXD and $\overline{\text{ERR}}$ will signal the wake-up interrupt even in case V_{CC} is not present.

The standby mode operates in the same way as the sleep mode but with a HIGH level on pin INH.

The power-on standby mode is the same as the standby mode, however, in this mode the battery power-on flag is shown on pin $\overline{\text{ERR}}$ instead of the wake-up interrupt signal. The output on pin RXD will show the wake-up interrupt. This mode is only for reading out the power-on flag.

Table 5. Normal operating and low power modes

Mode	Pin $\overline{\text{STB}}$	Pin EN	Pin $\overline{\text{ERR}}$		Pin RXD		Pin RTL switched to
			LOW	HIGH	LOW	HIGH	
Goto-sleep command	LOW	HIGH	wake-up interrupt signal ^[1]	[2] [3]	wake-up interrupt signal ^[1]	[2] [3]	V_{BAT}
Sleep	LOW	LOW ^[4]					
Standby	LOW	LOW					
Power-on standby	HIGH	LOW	V_{BAT} power-on flag ^[5]		wake-up interrupt signal ^[1]		V_{BAT}
Normal operating	HIGH	HIGH	error flag	no error flag	dominant received data	recessive received data	V_{CC}

[1] Wake-up interrupts are released when entering normal operating mode.

[2] For TJA1055T a diode is added in series with the high-side driver of $\overline{\text{ERR}}$ and RXD to prevent a reverse current from $\overline{\text{ERR}}$ to V_{CC} in the unpowered state.

[3] For TJA1055T/3, $\overline{\text{ERR}}$ and RXD are open-drain.

[4] In case the goto-sleep command was used before. When V_{CC} drops, pin EN will become LOW, but due to the fail-safe functionality this does not effect the internal functions.

[5] V_{BAT} power-on flag will be reset when entering normal operating mode.

Wake-up requests are recognized by the transceiver through two possible channels:

- The bus lines for remote wake-up
- Pin $\overline{\text{WAKE}}$ for local wake-up

In order to wake-up the transceiver remotely through the bus lines, a filter mechanism is integrated. This mechanism makes sure that noise and any present bus failure conditions do not result into an erroneous wake-up. Because of this mechanism it is not sufficient to simply pull the CANH or CANL bus lines to a dominant level for a certain time. To guarantee a successful remote wake-up under all conditions, a message frame with a dominant phase of at least the maximum specified $t_{\text{dom}}(\text{CANH})$ or $t_{\text{dom}}(\text{CANL})$ in it is required.

A local wake-up through pin $\overline{\text{WAKE}}$ is detected by a rising or falling edge with a consecutive level exceeding the maximum specified t_{WAKE} .

On a wake-up request the transceiver will set the output on pin INH to HIGH which can be used to activate the external supply voltage regulator.

A wake-up request is signalled on $\overline{\text{ERR}}$ or RXD with an active LOW signal. So the external microcontroller can activate the transceiver (switch to normal operating mode) via pins $\overline{\text{STB}}$ and EN.

To prevent a false remote wake-up due to transients or RF fields, the wake-up voltage levels have to be maintained for a certain period of time. In the low power modes the failure detection circuit remains partly active to prevent an increased power consumption in the event of failures 3, 3a, 4 and 7.

To prevent a false local wake-up during an open wire at pin $\overline{\text{WAKE}}$, this pin has a weak pull-up current source towards V_{BAT} . However, in order to protect the transceiver against any EMC immunity issues, it is recommended to connect a not used pin $\overline{\text{WAKE}}$ to pin BAT. Pin INH is set to floating only if the goto-sleep command is entered successfully. To enter a successful goto-sleep command under all conditions, this command must be kept stable for the maximum specified $t_{\text{h(sleep)}}$.

Pin INH will be set to a HIGH level again by the following events only:

- V_{BAT} power-on (cold start)
- Rising or falling edge on pin $\overline{\text{WAKE}}$
- A message frame with a dominant phase of at least the maximum specified $t_{\text{dom(CANH)}}$ or $t_{\text{dom(CANL)}}$, while pin EN or pin $\overline{\text{STB}}$ is at a LOW level
- Pin $\overline{\text{STB}}$ goes to a HIGH level with V_{CC} active

To provide fail-safe functionality, the signals on pins $\overline{\text{STB}}$ and EN will internally be set to LOW when V_{CC} is below a certain threshold voltage ($V_{\text{CC(stb)}}$). An unused output pin INH can simply be left open within the application.

7.3 Power-on

After power-on (V_{BAT} switched on) the signal on pin INH will become HIGH and an internal power-on flag will be set. This flag can be read in the power-on standby mode through pin ERR ($\text{STB} = 1$; $\text{EN} = 0$) and will be reset by entering the normal operating mode.

7.4 Protections

A current limiting circuit protects the transmitter output stages against short-circuit to positive and negative battery voltage.

If the junction temperature exceeds the typical value of 175 °C, the transmitter output stages are disabled. Because the transmitter is responsible for the major part of the power dissipation, this will result in a reduced power dissipation and hence a lower chip temperature. All other parts of the device will continue to operate.

The pins CANH and CANL are protected against electrical transients which may occur in an automotive environment.

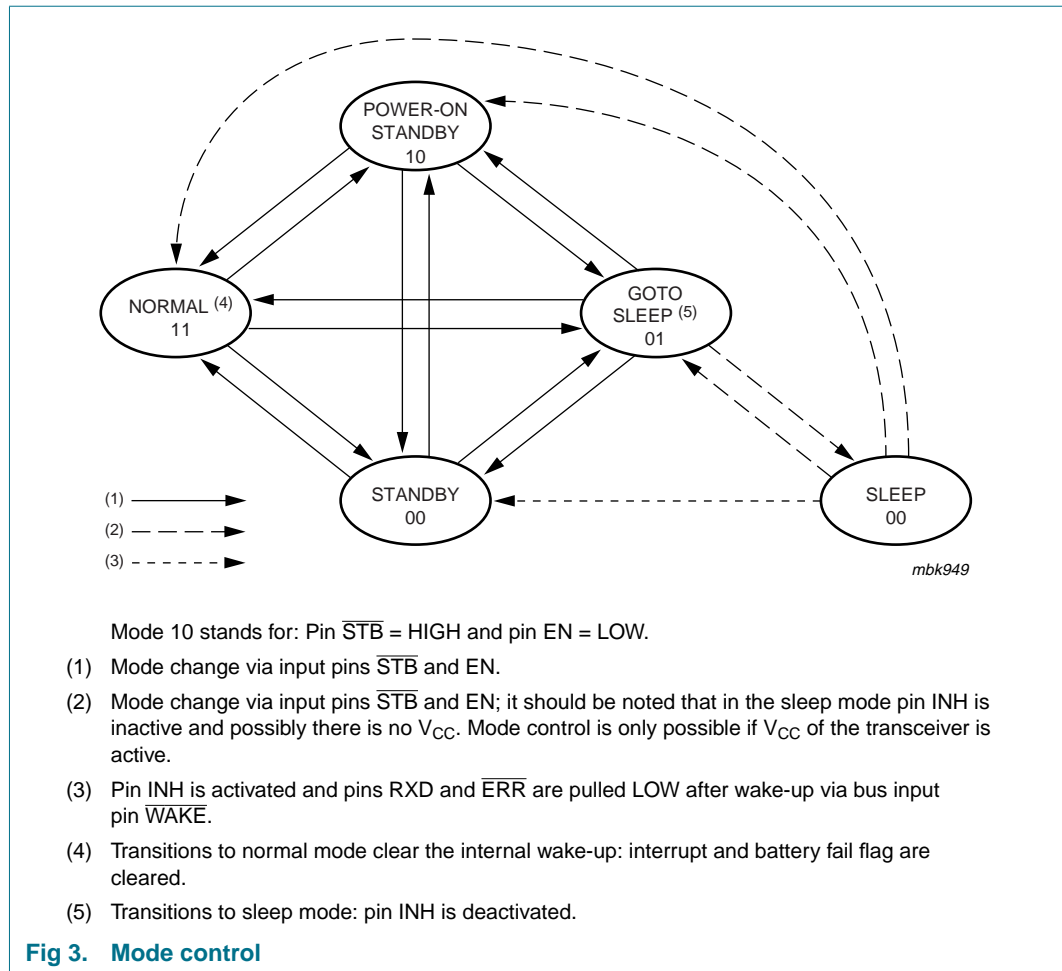

8. Limiting values

Table 6. Limiting values

In accordance with the Absolute Maximum Rating System (IEC 60134).^[1]

Symbol	Parameter	Conditions	Min	Max	Unit
V_{CC}	supply voltage		-0.3	+6	V
V_{BAT}	battery supply voltage		-0.3	+58	V
V_{TXD}	voltage on pin TXD		-0.3	$V_{CC} + 0.3$	V
V_{RXD}	voltage on pin RXD		-0.3	$V_{CC} + 0.3$	V
V_{ERR}	voltage on pin \overline{ERR}		-0.3	$V_{CC} + 0.3$	V
V_{STB}	voltage on pin \overline{STB}		-0.3	$V_{CC} + 0.3$	V
V_{EN}	voltage on pin EN		-0.3	$V_{CC} + 0.3$	V
V_{CANH}	voltage on pin CANH	with respect to any other pin	-58	+58	V
V_{CANL}	voltage on pin CANL	with respect to any other pin	-58	+58	V
$V_{trt(n)}$	transient voltage on pins CANH and CANL	see Figure 7 and 8	-150	+100	V

Table 6. Limiting values ...continuedIn accordance with the Absolute Maximum Rating System (IEC 60134).^[1]

Symbol	Parameter	Conditions	Min	Max	Unit
$V_{I(WAKE)}$	input voltage on pin \overline{WAKE}	with respect to any other pin	-0.3 V	58	V
$I_{I(WAKE)}$	input current on pin \overline{WAKE}		^[2] -15	-	mA
V_{INH}	voltage on pin INH		-0.3	$V_{BAT} + 0.3$	V
V_{RTH}	voltage on pin RTH	with respect to any other pin	-58	+58	V
V_{RTL}	voltage on pin RTL	with respect to any other pin	-58	+58	V
R_{RTH}	termination resistance on pin RTH		500	16000	Ω
R_{RTL}	termination resistance on pin RTL		500	16000	Ω
T_{vj}	virtual junction temperature		^[3] -40	+150	$^{\circ}\text{C}$
T_{stg}	storage temperature		-55	+150	$^{\circ}\text{C}$
V_{esd}	electrostatic discharge voltage	human body model ^[4]			
		pins RTH, RTL, CANH and CANL	-8	+8	kV
		all other pins	-2	+2	kV
		IEC 61000-4-2 (330 Ω and 150 pF) ^[5]			
		pins RTH, RTL, CANH and CANL			kV
machine model ^[6]					
	any pin	-300	+300	V	

[1] All voltages are defined with respect to pin GND, unless otherwise specified. Positive current flows into the device.

[2] Only relevant if $V_{WAKE} < V_{GND} - 0.3$ V; current will flow into pin GND.

[3] Junction temperature in accordance with "IEC 60747-1". An alternative definition is: $T_{vj} = T_{amb} + P \times R_{th(vj-a)}$ where $R_{th(vj-a)}$ is a fixed value to be used for the calculation of T_{vj} . The rating for T_{vj} limits the allowable combinations of power dissipation (P) and operating ambient temperature (T_{amb}).

[4] Equivalent to discharging a 100 pF capacitor through a 1.5 k Ω resistor.

[5] The ESD performance of pins CANH, CANL, RTH and RTL, with respect to GND, was verified by an external test house in accordance with IEC-61000-4-2 (C = 150 pF, R = 330 Ω). The results were equal to or better than ± 6 kV

[6] Equivalent to discharging a 200 pF capacitor through a 10 Ω resistor and a 0.75 μH coil.

9. Thermal characteristics

Table 7. Thermal characteristics

Symbol	Parameter	Conditions	Typ	Unit
$R_{th(j-a)}$	thermal resistance from junction to ambient	in free air	120	K/W
$R_{th(j-s)}$	thermal resistance from junction to substrate	in free air	40	K/W

10. Static characteristics

Table 8. Static characteristics

$V_{CC} = 4.75\text{ V to }5.25\text{ V}$; $V_{BAT} = 5.0\text{ V to }40\text{ V}$; $V_{STB} = V_{CC}$; $T_{vj} = -40\text{ }^{\circ}\text{C to }+150\text{ }^{\circ}\text{C}$; all voltages are defined with respect to ground; positive currents flow into the device; unless otherwise specified.^[1]

Symbol	Parameter	Conditions	Min	Typ	Max	Unit	
Supplies (pins V_{CC} and BAT)							
V_{CC}	supply voltage		4.75	-	5.25	V	
$V_{CC(stb)}$	supply voltage for forced standby mode (fail-safe)		3.5	-	4.5	V	
I_{CC} supply current		normal operating mode; $V_{TXD} = V_{CC}$ (recessive)	<td>	6	<td>	mA	
		normal operating mode; $V_{TXD} = 0\text{ V}$ (dominant); no load	<td>	13	<td>	mA	
		low power modes at $V_{TXD} = V_{CC}$					
		$T_{amb} = -40\text{ }^{\circ}\text{C to }+85\text{ }^{\circ}\text{C}$	0	0	5	μA	
		$T_{amb} = +85\text{ }^{\circ}\text{C to }+125\text{ }^{\circ}\text{C}$	0	0	<td>	μA	
V_{BAT}	battery supply voltage	no time limit	-0.3	-	+40	V	
		operating mode	5.0	-	40	V	
		load dump	-	-	58	V	
I_{BAT}	battery supply current	low power mode at $V_{RTL} = V_{WAKE} = V_{INH} = V_{BAT}$					
		$V_{BAT} = 14\text{ V}$	<td>	25	<td>	μA	
		$V_{BAT} = 5\text{ V to }40\text{ V}$	<td>	-	100	μA	
		normal operating mode at $V_{RTL} = V_{WAKE} = V_{INH} = V_{BAT}$					
		$V_{BAT} = 5\text{ V to }40\text{ V}$	<td>	150	300	μA	
$V_{pof(BAT)}$	power-on flag voltage on pin BAT	low power modes					
		power-on flag set	-	-	4	V	
		power-on flag not set	5	-	-	V	
$I_{sup(tot)}$	total supply current	low power modes; $V_{CC} = 5\text{ V}$; $V_{BAT} = V_{WAKE} = V_{INH} = 12\text{ V}$	-	25	<td>	μA	
Pins \overline{STB}, EN and TXD							
V_{IH}	HIGH-level input voltage		2	-	7	V	
V_{IL}	LOW-level input voltage		-0.3	-	+0.8	V	
I_{IH}	HIGH-level input current	pins \overline{STB} and EN	$V_I = 4\text{ V}$	-	9	20	μA
		pin TXD (TJA1055T)	$V_I = 3\text{ V}$	<td>	-80	<td>	μA
		pin TXD (TJA1055T/3)	normal operating mode; $V_I = 2.4\text{ V}$	<td>	9	20	μA
		low power mode; $V_I = 2.4\text{ V}$	<td>	0.9	<td>	μA	

Table 8. Static characteristics ...continued

$V_{CC} = 4.75\text{ V to }5.25\text{ V}$; $V_{BAT} = 5.0\text{ V to }40\text{ V}$; $V_{STB} = V_{CC}$; $T_{vj} = -40\text{ }^{\circ}\text{C to }+150\text{ }^{\circ}\text{C}$; all voltages are defined with respect to ground; positive currents flow into the device; unless otherwise specified.^[1]

Symbol	Parameter	Conditions	Min	Typ	Max	Unit
I_{IL}	LOW-level input current					
	pins \overline{STB} and EN	$V_I = 1\text{ V}$	4	8	-	μA
	pin TXD (TJA1055T)	$V_I = 1\text{ V}$	<tbd>	-240	<tbd>	μA
	pin TXD (TJA1055T/3)	normal operating mode; $V_I = 1\text{ V}$ low power mode; $V_I = 1\text{ V}$	4 <tbd>	8 0.9	- <tbd>	μA μA
Pins RXD and \overline{ERR} (TJA1055T)						
$V_{OH(norm)}$	HIGH-level output voltage in normal mode					
	on pin \overline{ERR}	$I_O = -100\text{ }\mu\text{A}$	$V_{CC} - 0.9$	-	V_{CC}	V
	on pin RXD	$I_O = -1\text{ mA}$	$V_{CC} - 0.9$	-	V_{CC}	V
$V_{OH(lp)}$	HIGH-level output voltage in low-power mode					
	on pin \overline{ERR}	$I_O = -100\text{ }\mu\text{A}$	$V_{CC} - 1.1$	$V_{CC} - 0.7$	$V_{CC} - 0.4$	V
	on pin RXD	$I_O = -100\text{ }\mu\text{A}$	$V_{CC} - 1.1$	$V_{CC} - 0.7$	$V_{CC} - 0.4$	V
V_{OL}	LOW-level output voltage	$I_O = 1.6\text{ mA}$	0	-	0.4	V
		$I_O = 1.2\text{ mA}$; $V_{CC} < 4.75\text{ V}$	0	-	0.4	V
		$I_O = 5\text{ mA}$	0	-	1.5	V
Pins RXD and \overline{ERR} (TJA1055T/3)						
I_{OL}	LOW-level output current	$V_O = 0.4\text{ V}$	1.3	3.5	-	mA
I_{LH}	HIGH-level leakage current	$V_O = 3\text{ V}$	-5	-	+5	μA
Pin WAKE						
I_{IL}	LOW-level input current	$V_{WAKE} = 0\text{ V}$; $V_{BAT} = 40\text{ V}$	-12	-4	-1	μA
$V_{th(wake)}$	wake-up threshold voltage	$V_{STB} = 0\text{ V}$	2.5	3.2	3.9	V
Pin INH						
ΔV_H	HIGH-level voltage drop	$I_{INH} = -0.18\text{ mA}$	-	-	0.8	V
$ I_L $	leakage current	sleep mode; $V_{INH} = 0\text{ V}$	-	-	5	μA
Pins CANH and CANL						
$V_{th(dif)}$	differential receiver threshold voltage	no failures and bus failures 1, 2, 5 and 6a; see Figure 4				
		$V_{CC} = 5\text{ V}$	-3.5	-3.2	-2.9	V
		$V_{CC} = 4.75\text{ V to }5.25\text{ V}$	$-0.70V_{CC}$	$-0.64V_{CC}$	$-0.58V_{CC}$	V

Table 8. Static characteristics ...continued

$V_{CC} = 4.75\text{ V to }5.25\text{ V}$; $V_{BAT} = 5.0\text{ V to }40\text{ V}$; $V_{STB} = V_{CC}$; $T_{vj} = -40\text{ }^{\circ}\text{C to }+150\text{ }^{\circ}\text{C}$; all voltages are defined with respect to ground; positive currents flow into the device; unless otherwise specified.^[1]

Symbol	Parameter	Conditions	Min	Typ	Max	Unit
$V_{O(\text{reces})}$	recessive output voltage	$V_{TXD} = V_{CC}$				
	on pin CANH	$R_{RTH} < 4\text{ k}\Omega$	-	-	0.2	V
	on pin CANL	$R_{RTL} < 4\text{ k}\Omega$	$V_{CC} - 0.2$	-	-	V
$V_{O(\text{dom})}$	dominant output voltage	$V_{TXD} = 0\text{ V}$; $V_{EN} = V_{CC}$				
	on pin CANH	$I_{CANH} = -40\text{ mA}$	$V_{CC} - 1.4$	-	-	V
	on pin CANL	$I_{CANL} = 40\text{ mA}$	-	-	1.4	V
$I_{O(\text{CANH})}$	output current on pin CANH	normal operating mode; $V_{CANH} = 0\text{ V}$; $V_{TXD} = 0\text{ V}$	-110	-80	-45	mA
		low power modes; $V_{CANH} = 0\text{ V}$; $V_{CC} = 5\text{ V}$	-	-0.25	-	μA
$I_{O(\text{CANL})}$	output current on pin CANL	normal operating mode; $V_{CANL} = 14\text{ V}$; $V_{TXD} = 0\text{ V}$	45	70	100	mA
		low power modes; $V_{CANL} = 14\text{ V}$; $V_{BAT} = 14\text{ V}$	-	0	-	μA
$V_{\text{det}(\text{sc})(\text{CANH})}$	detection voltage for short-circuit to battery voltage on pin CANH	normal operating mode; $V_{CC} = 5\text{ V}$	1.5	1.7	1.85	V
		low power modes	1.1	1.8	2.5	V
$V_{\text{det}(\text{sc})(\text{CANL})}$	detection voltage for short-circuit to battery voltage on pin CANL	normal operating mode $V_{CC} = 5\text{ V}$	6.6	7.2	7.8	V
		$V_{CC} = 4.75\text{ V to }5.25\text{ V}$	$1.32V_{CC}$	$1.44V_{CC}$	$1.56V_{CC}$	V
$V_{\text{th}(\text{wake})}$	wake-up threshold voltage					
	on pin CANL	low power modes	2.5	3.2	3.9	V
	on pin CANH	low power modes	1.1	1.8	2.5	V
$\Delta V_{\text{th}(\text{wake})}$	difference of wake-up threshold voltages (on pins CANL and CANH)	low power modes	0.8	1.4	-	V
$V_{\text{th}(\text{se})(\text{CANH})}$	single-ended receiver threshold voltage on pin CANH	normal operating mode and failures 4, 6 and 7 $V_{CC} = 5\text{ V}$	1.5	1.7	1.85	V
		$V_{CC} = 4.75\text{ V to }5.25\text{ V}$	$0.30V_{CC}$	$0.34V_{CC}$	$0.37V_{CC}$	V
$V_{\text{th}(\text{se})(\text{CANL})}$	single-ended receiver threshold voltage on pin CANL	normal operating mode and failures 3 and 3a $V_{CC} = 5\text{ V}$	3.15	3.3	3.45	V
		$V_{CC} = 4.75\text{ V to }5.25\text{ V}$	$0.63V_{CC}$	$0.66V_{CC}$	$0.69V_{CC}$	V
$R_{i(\text{se})(\text{CANH})}$	single-ended input resistance on pin CANH	normal operating mode	110	165	270	k Ω
$R_{i(\text{se})(\text{CANL})}$	single-ended input resistance on pin CANL	normal operating mode	110	165	270	k Ω

Table 8. Static characteristics ...continued

$V_{CC} = 4.75\text{ V to }5.25\text{ V}$; $V_{BAT} = 5.0\text{ V to }40\text{ V}$; $V_{STB} = V_{CC}$; $T_{vj} = -40\text{ }^{\circ}\text{C to }+150\text{ }^{\circ}\text{C}$; all voltages are defined with respect to ground; positive currents flow into the device; unless otherwise specified.^[1]

Symbol	Parameter	Conditions	Min	Typ	Max	Unit
$R_{i(\text{dif})}$	differential input resistance	normal operating mode	220	330	540	k Ω
Pins RTH and RTL						
$R_{\text{sw}(\text{RTL})}$	switch-on resistance on pin RTL	normal operating mode; switch-on resistance between pin RTL and V_{CC} ; $ I_O < 10\text{ mA}$	-	40	100	Ω
$R_{\text{sw}(\text{RTH})}$	switch-on resistance on pin RTH	normal operating mode; switch-on resistance between pin RTH and ground; $ I_O < 10\text{ mA}$	-	40	100	Ω
$V_{O(\text{RTH})}$	output voltage on pin RTH	low power modes; $I_O = 100\text{ }\mu\text{A}$	-	0.7	1.0	V
$I_{O(\text{RTL})}$	output current on pin RTL	low power modes; $V_{\text{RTL}} = 0\text{ V}$	-1.5	-0.65	-0.1	mA
$I_{\text{pu}(\text{RTL})}$	pull-up current on pin RTL	normal operating mode and failures 4, 6 and 7	-	75	-	μA
$I_{\text{pd}(\text{RTH})}$	pull-down current on pin RTH	normal operating mode and failures 3 and 3a	-	75	-	μA
Thermal shutdown						
$T_{j(\text{sd})}$	shutdown junction temperature		160	175	190	$^{\circ}\text{C}$

[1] All parameters are guaranteed over the virtual junction temperature range by design, but only 100 % tested at $T_{\text{amb}} = 125\text{ }^{\circ}\text{C}$ for dies on wafer level, and above this for cased products 100 % tested at $T_{\text{amb}} = 25\text{ }^{\circ}\text{C}$, unless otherwise specified.

11. Dynamic characteristics

Table 9. Dynamic characteristics

$V_{CC} = 4.75\text{ V to }5.25\text{ V}$; $V_{BAT} = 5.0\text{ V to }40\text{ V}$; $V_{STB} = V_{CC}$; $T_{vj} = -40\text{ }^{\circ}\text{C to }+150\text{ }^{\circ}\text{C}$; all voltages are defined with respect to ground; unless otherwise specified.^[1]

Symbol	Parameter	Conditions	Min	Typ	Max	Unit
$t_{t(\text{reces-dom})}$	transition time for recessive to dominant (on pins CANL and CANH)	between 10 % and 90 %; $R_{\text{CAN_L}} = R_{\text{CAN_H}} = 125\text{ }\Omega$; $C_{\text{CAN_L}} = C_{\text{CAN_H}} = 10\text{ nF}$; see Figure 5 and 6	0.3	0.6	-	μs
$t_{t(\text{dom-reces})}$	transition time for dominant to recessive (on pins CANL and CANH)	between 10 % and 90 %; $R_{\text{CAN_L}} = R_{\text{CAN_H}} = 125\text{ }\Omega$; $C_{\text{CAN_L}} = C_{\text{CAN_H}} = 1\text{ nF}$; see Figure 5 and 6	0.3	0.7	-	μs

Table 9. Dynamic characteristics ...continued

$V_{CC} = 4.75\text{ V to }5.25\text{ V}$; $V_{BAT} = 5.0\text{ V to }40\text{ V}$; $V_{STB} = V_{CC}$; $T_{vj} = -40\text{ }^{\circ}\text{C to }+150\text{ }^{\circ}\text{C}$; all voltages are defined with respect to ground; unless otherwise specified.^[1]

Symbol	Parameter	Conditions	Min	Typ	Max	Unit
$t_{PD(L)}$	propagation delay TXD (LOW) to RXD (LOW)	no failures; $R_{CAN_L} = R_{CAN_H} = 125\ \Omega$; $C_{CAN_L} = C_{CAN_H} = 1\text{ nF}$; see Figure 4 to Figure 6	-	-	1.5	μs
		all failures except CAN_L shorted to CAN_H; $R_{CAN_L} = R_{CAN_H} = 125\ \Omega$; $C_{CAN_L} = C_{CAN_H} = 1\text{ nF}$; see Figure 4 to Figure 6	-	-	1.9	μs
		failure 7, CAN_L shorted to CAN_H; $R_{CAN_L} = 1\text{ M}\Omega$; $R_{CAN_H} = 125\ \Omega$; $C_{CAN_L} = C_{CAN_H} = 1\text{ nF}$; see Figure 4 to Figure 6	-	-	1.9	μs
$t_{PD(H)}$	propagation delay TXD (HIGH) to RXD (HIGH)	no failures; $R_{CAN_L} = R_{CAN_H} = 125\ \Omega$; $C_{CAN_L} = C_{CAN_H} = 1\text{ nF}$; see Figure 4 to Figure 6	-	-	1.5	μs
		all failures except CAN_L shorted to CAN_H; $R_{CAN_L} = R_{CAN_H} = 125\ \Omega$; $C_{CAN_L} = C_{CAN_H} = 1\text{ nF}$; see Figure 4 to Figure 6	-	-	1.9	μs
		failure 7, CAN_L shorted to CAN_H; $R_{CAN_L} = 1\text{ M}\Omega$; $R_{CAN_H} = 125\ \Omega$; $C_{CAN_L} = C_{CAN_H} = 1\text{ nF}$; see Figure 4 to Figure 6	-	-	1.9	μs
$t_{d(\text{sleep})}$	delay time to sleep		[2] 5	-	50	μs
$t_{dis(\text{TxD})}$	disable time of TxD permanent dominant timer	normal operating mode; $V_{\text{TXD}} = 0\text{ V}$	0.75	-	4	ms
$t_{dom(\text{CANH})}$	dominant time on pin CANH	low power modes; $V_{\text{BAT}} = 14\text{ V}$	[2] 7	-	38	μs
$t_{dom(\text{CANL})}$	dominant time on pin CANL	low power modes; $V_{\text{BAT}} = 14\text{ V}$	[2] 7	-	38	μs
t_{WAKE}	local wake-up time on pin WAKE	low power modes; $V_{\text{BAT}} = 14\text{ V}$; for wake-up after receiving a falling or rising edge	[2] 7	-	38	μs
t_{det}	failure detection time	normal operating mode				
		failures 3 and 3a	1.6	-	8.0	ms
		failures 4, 6 and 7	0.3	-	1.6	ms
		low power modes; $V_{\text{BAT}} = 14\text{ V}$				
		failures 3 and 3a	1.6	-	8.0	ms
	failures 4 and 7	0.1	-	1.6	ms	

Table 9. Dynamic characteristics ...continued

$V_{CC} = 4.75\text{ V to }5.25\text{ V}$; $V_{BAT} = 5.0\text{ V to }40\text{ V}$; $V_{STB} = V_{CC}$; $T_{vj} = -40\text{ }^{\circ}\text{C to }+150\text{ }^{\circ}\text{C}$; all voltages are defined with respect to ground; unless otherwise specified.^[1]

Symbol	Parameter	Conditions	Min	Typ	Max	Unit
t_{rec}	failure recovery time	normal operating mode				
		failures 3 and 3a	0.3	-	1.6	ms
		failures 4 and 7	7	-	38	μs
		failure 6	125	-	750	μs
		low power modes; $V_{BAT} = 14\text{ V}$				
	failures 3, 3a, 4 and 7	0.3	-	1.6	ms	
n_{det}	pulse-count failure detection	difference between CANH and CANL; normal operating mode and failures 1, 2, 5 and 6a; pin $\overline{\text{ERR}}$ becomes LOW	-	4	-	
n_{rec}	number of consecutive pulses for failure recovery	on CANH and CANL simultaneously; failures 1, 2, 5 and 6a	-	4	-	

[1] All parameters are guaranteed over the virtual junction temperature range by design, but only 100 % tested at $T_{amb} = 125\text{ }^{\circ}\text{C}$ for dies on wafer level, and above this for cased products 100 % tested at $T_{amb} = 25\text{ }^{\circ}\text{C}$, unless otherwise specified.

[2] To guarantee a successful mode transition under all conditions, the maximum specified time must be applied.

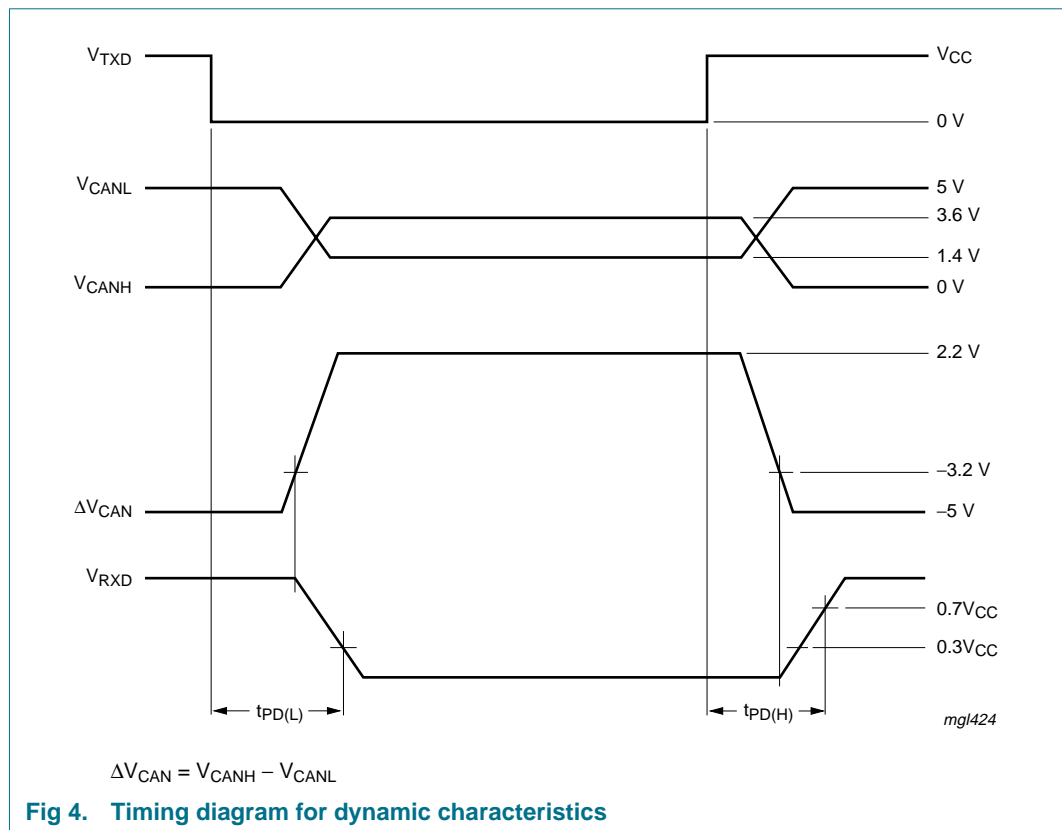
**Fig 4. Timing diagram for dynamic characteristics**

12. Test information

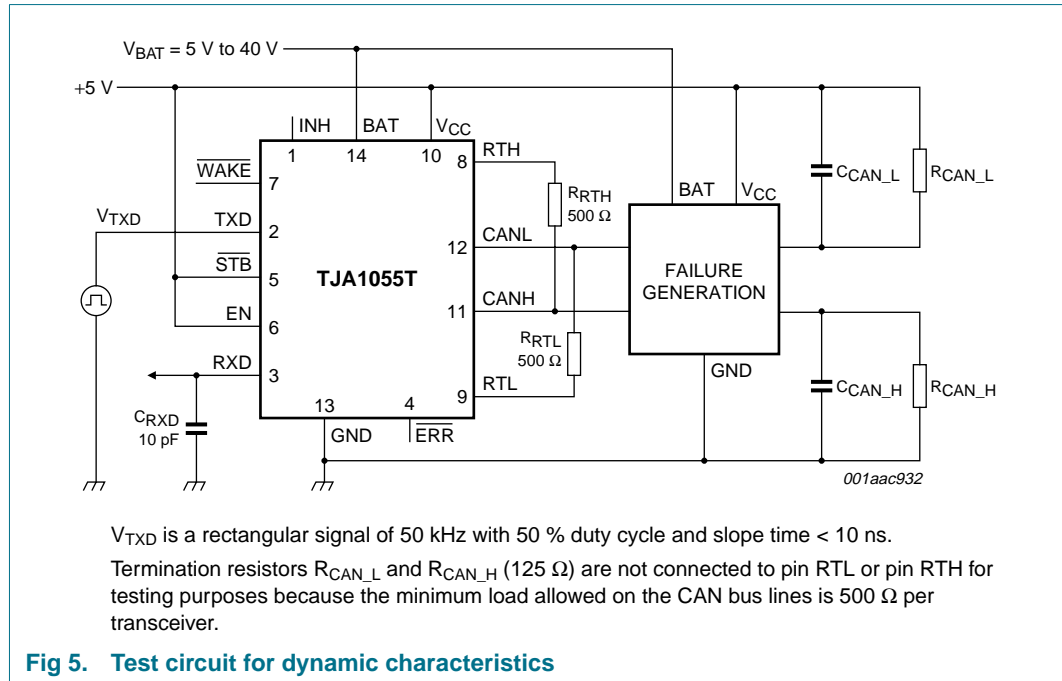

Fig 5. Test circuit for dynamic characteristics

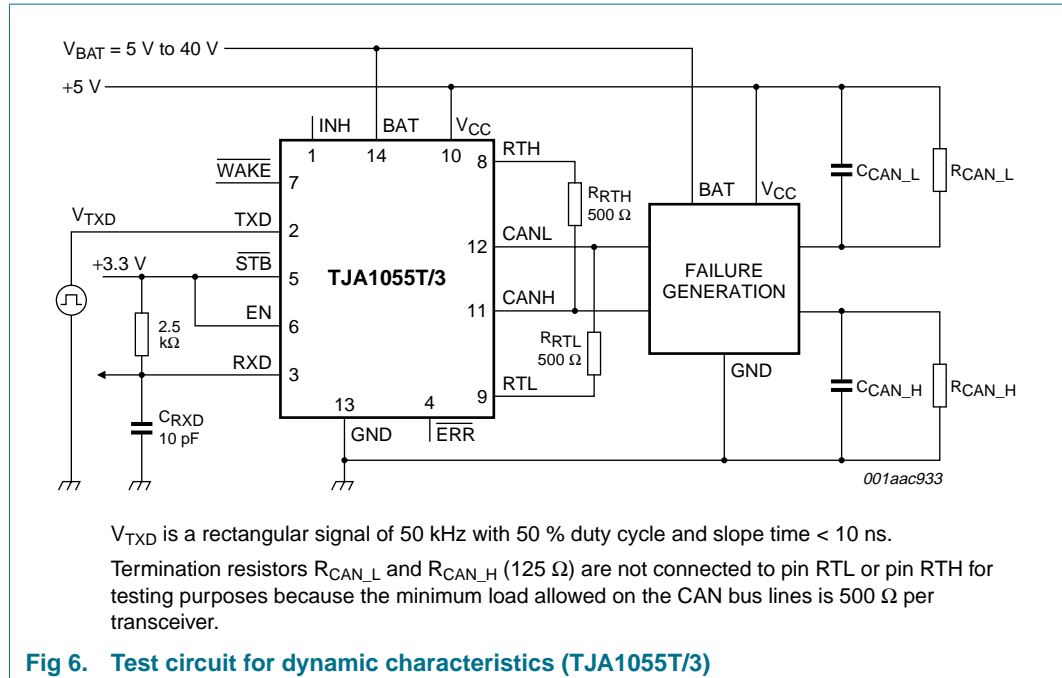
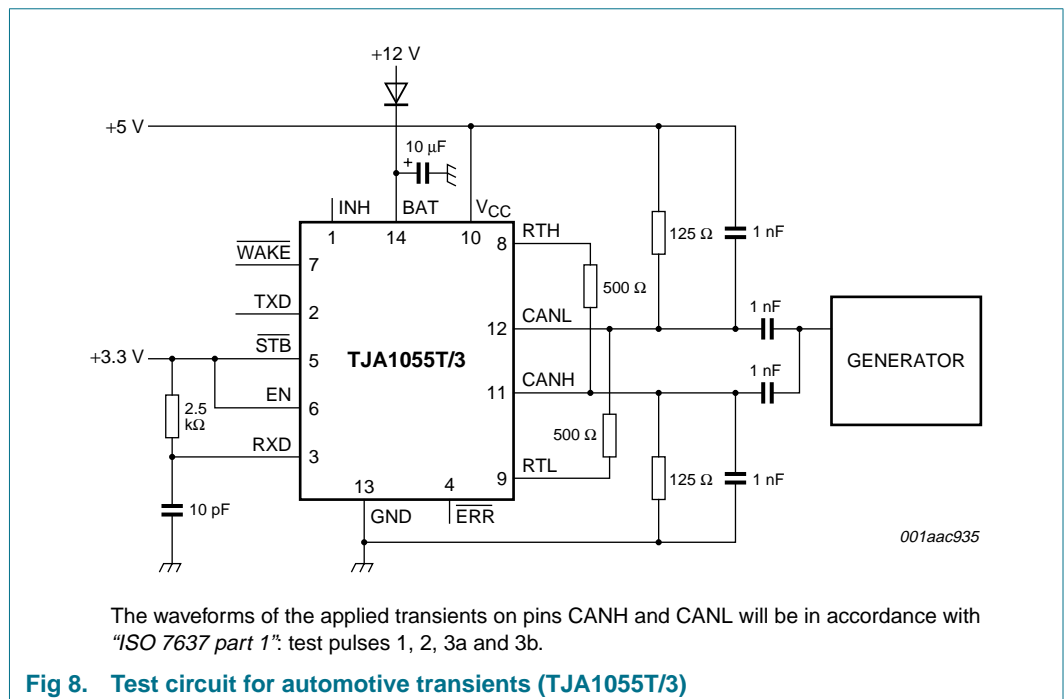
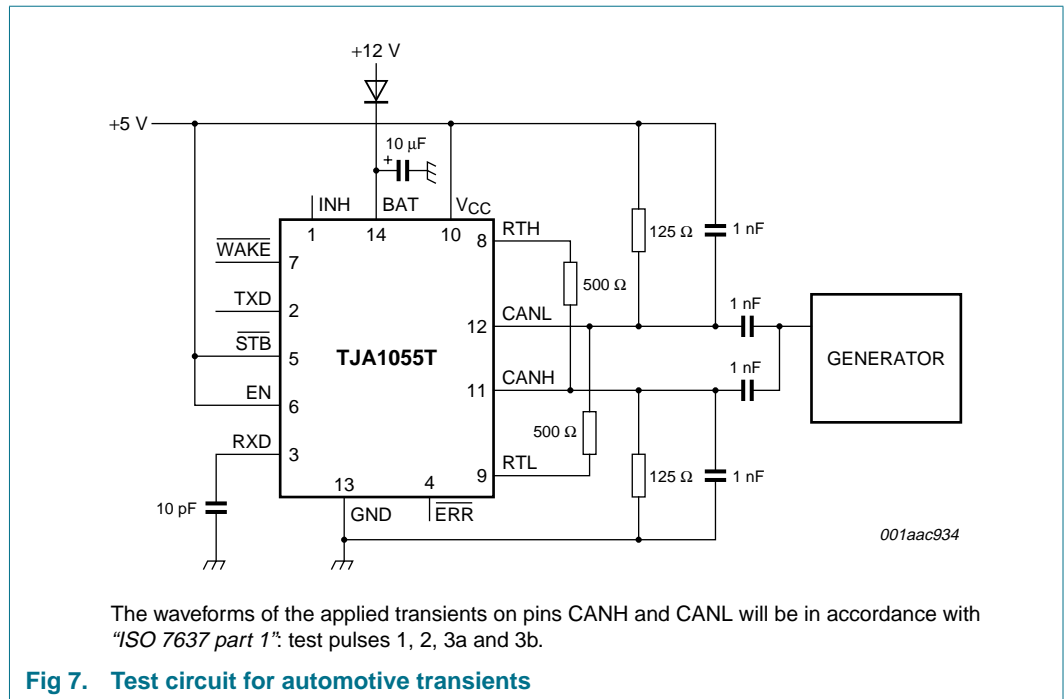
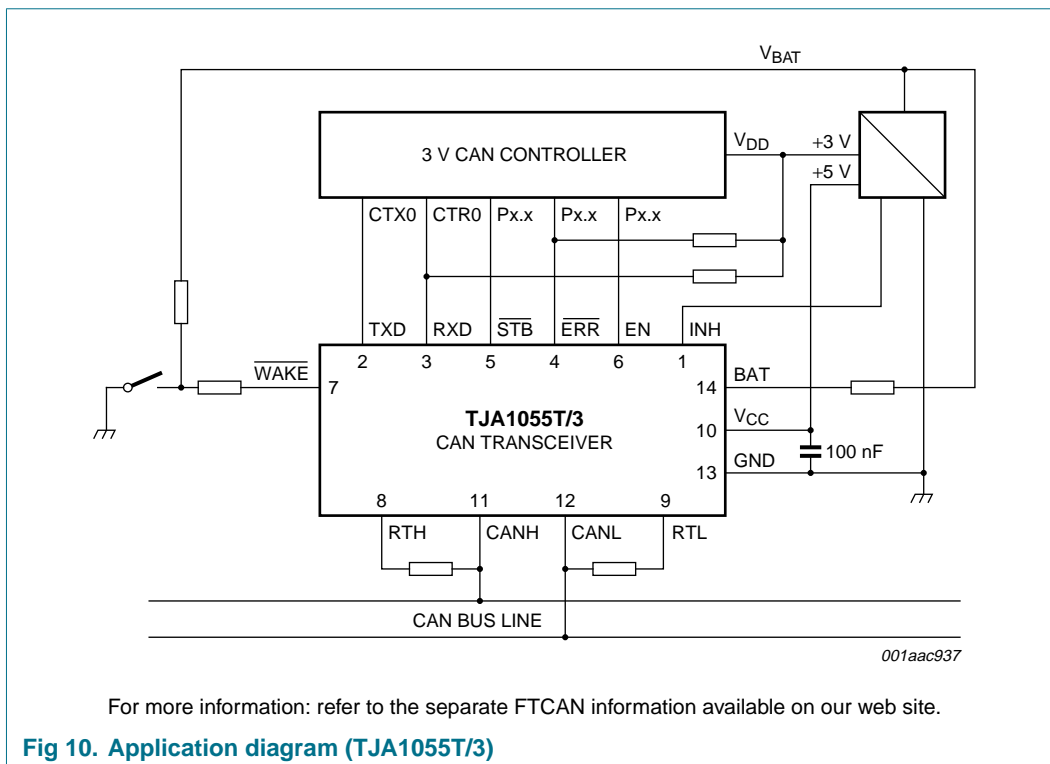
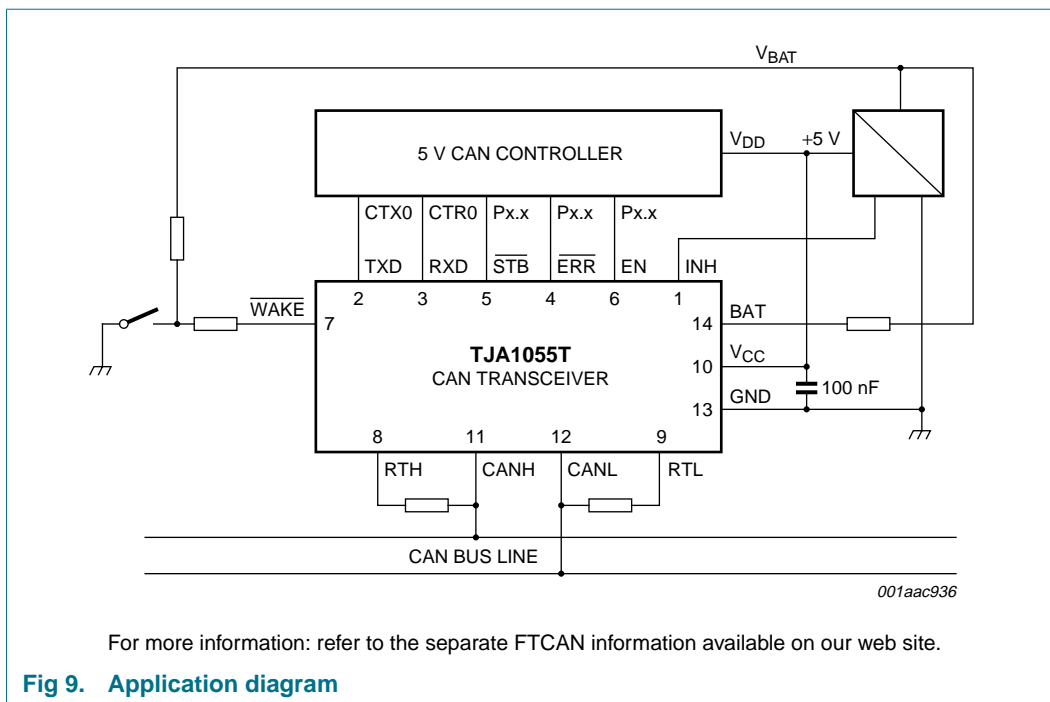

Fig 6. Test circuit for dynamic characteristics (TJA1055T/3)





12.1 Quality information

This product has been qualified to the appropriate Automotive Electronics Council (AEC) standard Q100 or Q101 and is suitable for use in automotive critical applications.

13. Bare die information

Table 10. Bonding pad locations

Symbol	Pad	Coordinates ^[1]	
		x	y
INH	1	<tbd>	<tbd>
TXD	2	<tbd>	<tbd>
RXD	3	<tbd>	<tbd>
$\overline{\text{ERR}}$	4	<tbd>	<tbd>
$\overline{\text{STB}}$	5	<tbd>	<tbd>
EN	6	<tbd>	<tbd>
$\overline{\text{WAKE}}$	7	<tbd>	<tbd>
RTH	8	<tbd>	<tbd>
RTL	9	<tbd>	<tbd>
V _{CC}	10	<tbd>	<tbd>
CANH	11	<tbd>	<tbd>
CANL	12	<tbd>	<tbd>
GND	13a	<tbd>	<tbd>
GND	13b	<tbd>	<tbd>
BAT	14	<tbd>	<tbd>

[1] All coordinates (μm) represent the position of the center of each pad with respect to the bottom left-hand corner of the top aluminium layer (see [Figure 11](#)).



14. Package outline

SO14: plastic small outline package; 14 leads; body width 3.9 mm

SOT108-1

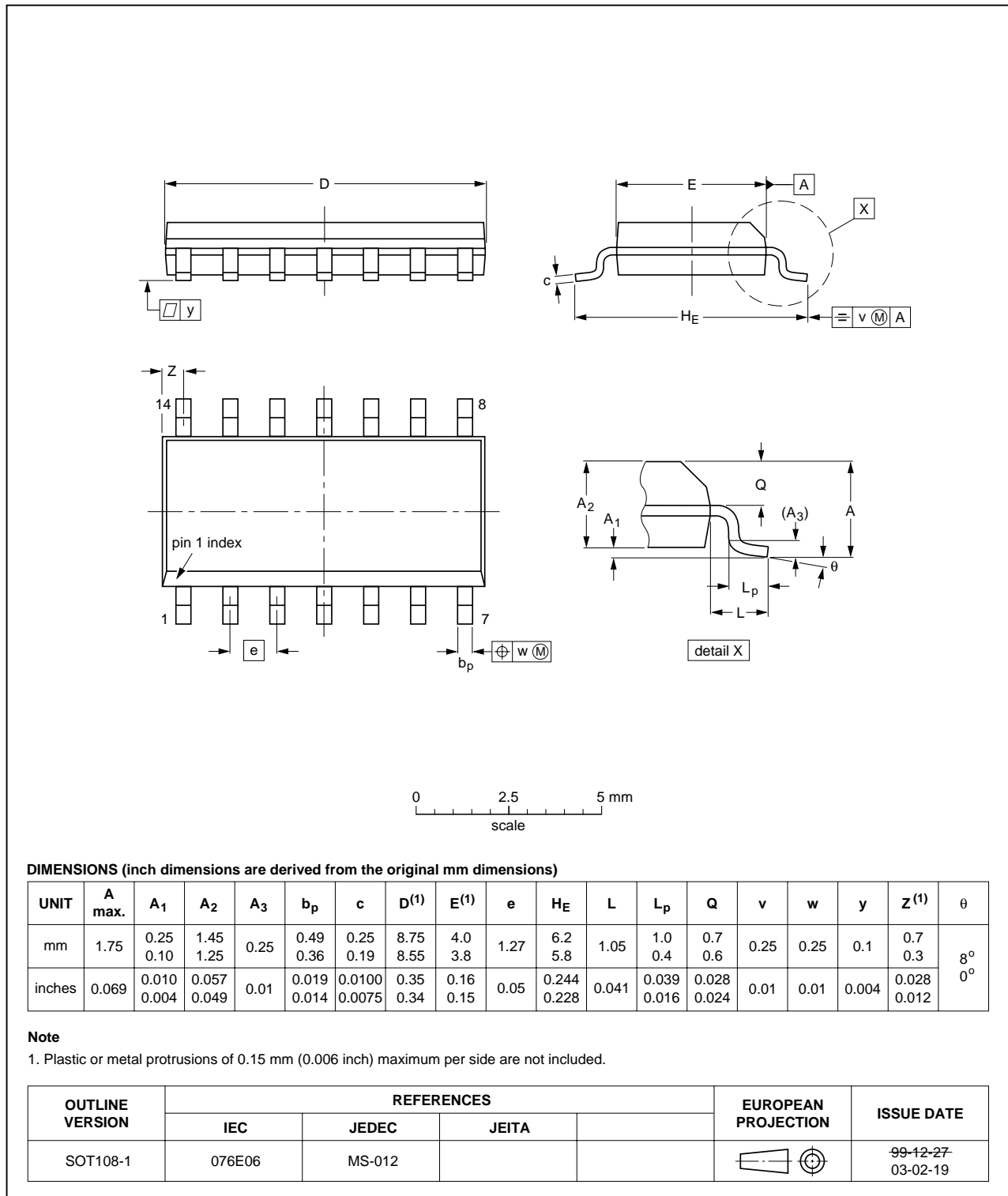

Fig 12. Package outline SOT108-1 (SO14)

15. Soldering

This text provides a very brief insight into a complex technology. A more in-depth account of soldering ICs can be found in Application Note *AN10365 "Surface mount reflow soldering description"*.

15.1 Introduction to soldering

Soldering is one of the most common methods through which packages are attached to Printed Circuit Boards (PCBs), to form electrical circuits. The soldered joint provides both the mechanical and the electrical connection. There is no single soldering method that is ideal for all IC packages. Wave soldering is often preferred when through-hole and Surface Mount Devices (SMDs) are mixed on one printed wiring board; however, it is not suitable for fine pitch SMDs. Reflow soldering is ideal for the small pitches and high densities that come with increased miniaturization.

15.2 Wave and reflow soldering

Wave soldering is a joining technology in which the joints are made by solder coming from a standing wave of liquid solder. The wave soldering process is suitable for the following:

- Through-hole components
- Leaded or leadless SMDs, which are glued to the surface of the printed circuit board

Not all SMDs can be wave soldered. Packages with solder balls, and some leadless packages which have solder lands underneath the body, cannot be wave soldered. Also, leaded SMDs with leads having a pitch smaller than ~0.6 mm cannot be wave soldered, due to an increased probability of bridging.

The reflow soldering process involves applying solder paste to a board, followed by component placement and exposure to a temperature profile. Leaded packages, packages with solder balls, and leadless packages are all reflow solderable.

Key characteristics in both wave and reflow soldering are:

- Board specifications, including the board finish, solder masks and vias
- Package footprints, including solder thieves and orientation
- The moisture sensitivity level of the packages
- Package placement
- Inspection and repair
- Lead-free soldering versus PbSn soldering

15.3 Wave soldering

Key characteristics in wave soldering are:

- Process issues, such as application of adhesive and flux, clinching of leads, board transport, the solder wave parameters, and the time during which components are exposed to the wave
- Solder bath specifications, including temperature and impurities

15.4 Reflow soldering

Key characteristics in reflow soldering are:

- Lead-free versus SnPb soldering; note that a lead-free reflow process usually leads to higher minimum peak temperatures (see [Figure 13](#)) than a PbSn process, thus reducing the process window
- Solder paste printing issues including smearing, release, and adjusting the process window for a mix of large and small components on one board
- Reflow temperature profile; this profile includes preheat, reflow (in which the board is heated to the peak temperature) and cooling down. It is imperative that the peak temperature is high enough for the solder to make reliable solder joints (a solder paste characteristic). In addition, the peak temperature must be low enough that the packages and/or boards are not damaged. The peak temperature of the package depends on package thickness and volume and is classified in accordance with [Table 11](#) and [12](#)

Table 11. SnPb eutectic process (from J-STD-020C)

Package thickness (mm)	Package reflow temperature (°C)	
	Volume (mm ³)	
	< 350	≥ 350
< 2.5	235	220
≥ 2.5	220	220

Table 12. Lead-free process (from J-STD-020C)

Package thickness (mm)	Package reflow temperature (°C)		
	Volume (mm ³)		
	< 350	350 to 2000	> 2000
< 1.6	260	260	260
1.6 to 2.5	260	250	245
> 2.5	250	245	245

Moisture sensitivity precautions, as indicated on the packing, must be respected at all times.

Studies have shown that small packages reach higher temperatures during reflow soldering, see [Figure 13](#).

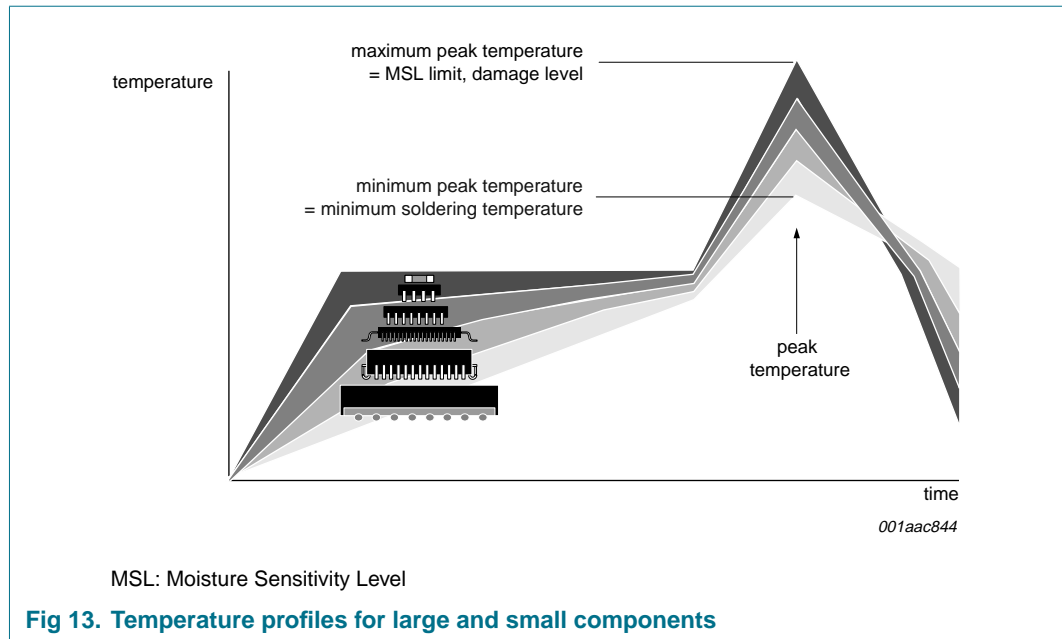

Fig 13. Temperature profiles for large and small components

For further information on temperature profiles, refer to Application Note AN10365 "Surface mount reflow soldering description".

16. Appendix

16.1 Overview of differences between the TJA1055 and the TJA1054A

Table 13. Limiting values

Symbol	Parameter	Conditions	TJA1055		TJA1054A		Unit
			Min	Max	Min	Max	
V_{CANH}	voltage on pin CANH		-58	+58	-27	+40	V
V_{CANL}	voltage on pin CANL		-58	+58	-27	+40	V
V_{esd}	electrostatic discharge voltage	human body model					
		pins RTH, RTL, CANH, and CANL	-8	+8	-4	+4	kV
		IEC 61000-4-2 (330 Ω and 150 pF)					
		pins RTH, RTL, CANH, and CANL	-6	+6	-1.5	+1.5	kV

Table 14. Bare die

Parameter	TJA1055U	TJA1054AU	Unit
Dimensions	<td> × <td>	1990 × 2730	μm
Bonding pad coordinates	<td>	<td>	

17. Revision history

Table 15. Revision history

Document ID	Release date	Data sheet status	Change notice	Supersedes
TJA1055_2	20061030	Preliminary data sheet	-	TJA1055_1
		<ul style="list-style-type: none"> The format of this data sheet has been redesigned to comply with the new identity guidelines of NXP Semiconductors. Legal texts have been adapted to the new company name where appropriate. Changed data sheet status to "Preliminary data sheet". Two sub bullets added to the "High ESD robustness" bullet in the Features section. Value change for V_{bat} in the Quick reference data table. Various values changed in the Limiting values table. Changes made to the Static characteristics table. In figures 6 and 8, the supply to resistor RXD has been changed to 3.3 V. Pins \overline{STB} and EN have also been connected to the 3.3 V supply. 		
TJA1055_1 (9397 750 14908)	20060801	Objective data sheet	-	-

18. Legal information

18.1 Data sheet status

Document status ^{[1][2]}	Product status ^[3]	Definition
Objective [short] data sheet	Development	This document contains data from the objective specification for product development.
Preliminary [short] data sheet	Qualification	This document contains data from the preliminary specification.
Product [short] data sheet	Production	This document contains the product specification.

[1] Please consult the most recently issued document before initiating or completing a design.

[2] The term 'short data sheet' is explained in section "Definitions".

[3] The product status of device(s) described in this document may have changed since this document was published and may differ in case of multiple devices. The latest product status information is available on the Internet at URL <http://www.nxp.com>.

18.2 Definitions

Draft — The document is a draft version only. The content is still under internal review and subject to formal approval, which may result in modifications or additions. NXP Semiconductors does not give any representations or warranties as to the accuracy or completeness of information included herein and shall have no liability for the consequences of use of such information.

Short data sheet — A short data sheet is an extract from a full data sheet with the same product type number(s) and title. A short data sheet is intended for quick reference only and should not be relied upon to contain detailed and full information. For detailed and full information see the relevant full data sheet, which is available on request via the local NXP Semiconductors sales office. In case of any inconsistency or conflict with the short data sheet, the full data sheet shall prevail.

18.3 Disclaimers

General — Information in this document is believed to be accurate and reliable. However, NXP Semiconductors does not give any representations or warranties, expressed or implied, as to the accuracy or completeness of such information and shall have no liability for the consequences of use of such information.

Right to make changes — NXP Semiconductors reserves the right to make changes to information published in this document, including without limitation specifications and product descriptions, at any time and without notice. This document supersedes and replaces all information supplied prior to the publication hereof.

Suitability for use — NXP Semiconductors products are not designed, authorized or warranted to be suitable for use in medical, military, aircraft, space or life support equipment, nor in applications where failure or

malfunction of a NXP Semiconductors product can reasonably be expected to result in personal injury, death or severe property or environmental damage. NXP Semiconductors accepts no liability for inclusion and/or use of NXP Semiconductors products in such equipment or applications and therefore such inclusion and/or use is at the customer's own risk.

Applications — Applications that are described herein for any of these products are for illustrative purposes only. NXP Semiconductors makes no representation or warranty that such applications will be suitable for the specified use without further testing or modification.

Limiting values — Stress above one or more limiting values (as defined in the Absolute Maximum Ratings System of IEC 60134) may cause permanent damage to the device. Limiting values are stress ratings only and operation of the device at these or any other conditions above those given in the Characteristics sections of this document is not implied. Exposure to limiting values for extended periods may affect device reliability.

Terms and conditions of sale — NXP Semiconductors products are sold subject to the general terms and conditions of commercial sale, as published at <http://www.nxp.com/profile/terms>, including those pertaining to warranty, intellectual property rights infringement and limitation of liability, unless explicitly otherwise agreed to in writing by NXP Semiconductors. In case of any inconsistency or conflict between information in this document and such terms and conditions, the latter will prevail.

No offer to sell or license — Nothing in this document may be interpreted or construed as an offer to sell products that is open for acceptance or the grant, conveyance or implication of any license under any copyrights, patents or other industrial or intellectual property rights.

18.4 Trademarks

Notice: All referenced brands, product names, service names and trademarks are the property of their respective owners.

19. Contact information

For additional information, please visit: <http://www.nxp.com>

For sales office addresses, send an email to: salesaddresses@nxp.com

20. Contents

1	General description	1
2	Features	1
2.1	Optimized for in-car low-speed communication	1
2.2	Bus failure management	1
2.3	Protections	2
2.4	Support for low power modes	2
3	Quick reference data	2
4	Ordering information	3
5	Block diagram	3
6	Pinning information	4
6.1	Pinning	4
6.2	Pin description	4
7	Functional description	5
7.1	Failure detector	5
7.2	Low power modes	7
7.3	Power-on	8
7.4	Protections	8
8	Limiting values	9
9	Thermal characteristics	10
10	Static characteristics	11
11	Dynamic characteristics	14
12	Test information	17
12.1	Quality information	19
13	Bare die information	20
14	Package outline	21
15	Soldering	22
15.1	Introduction to soldering	22
15.2	Wave and reflow soldering	22
15.3	Wave soldering	22
15.4	Reflow soldering	23
16	Appendix	24
16.1	Overview of differences between the TJA1055 and the TJA1054A	24
17	Revision history	26
18	Legal information	27
18.1	Data sheet status	27
18.2	Definitions	27
18.3	Disclaimers	27
18.4	Trademarks	27
19	Contact information	27
20	Contents	28

Please be aware that important notices concerning this document and the product(s) described herein, have been included in section 'Legal information'.

founded by

PHILIPS

© NXP B.V. 2006.

All rights reserved.

For more information, please visit: <http://www.nxp.com>

For sales office addresses, please send an email to: salesaddresses@nxp.com

Date of release: 30 October 2006

Document identifier: TJA1055_2

www.DataSheet4U.com