

CMFSH-3i
**SURFACE MOUNT
DUAL, ISOLATED
SILICON SCHOTTKY DIODES**



www.centrasemi.com



DESCRIPTION:

The CENTRAL SEMICONDUCTOR CMFSH-3i consists of two electrically isolated silicon Schottky diodes packaged in an epoxy molded SOT-143 surface mount case. This device is designed for fast switching applications requiring a low forward voltage drop.

MARKING CODE: C3I

MAXIMUM RATINGS: ($T_A=25^\circ\text{C}$)

Peak Repetitive Reverse Voltage
 Continuous Forward Current
 Peak Repetitive Forward Current
 Peak Forward Surge Current, $t_p=10\text{ms}$
 Power Dissipation
 Operating and Storage Junction Temperature
 Thermal Resistance

SYMBOL

V_{RRM} 30
 I_F 100
 I_{FRM} 200
 I_{FSM} 750
 P_D 350
 T_J, T_{stg} -65 to +150
 θ_{JA} 357

UNITS

V
 mA
 mA
 mA
 mW
 $^\circ\text{C}$
 $^\circ\text{C/W}$

ELECTRICAL CHARACTERISTICS PER DIODE: ($T_A=25^\circ\text{C}$ unless otherwise noted)

SYMBOL	TEST CONDITIONS	MIN	TYP	MAX	UNITS
I_R	$V_R=25\text{V}$		90	500	nA
I_R	$V_R=25\text{V}, T_A=100^\circ\text{C}$		25	100	μA
BV_R	$I_R=100\mu\text{A}$	30			V
V_F	$I_F=2.0\text{mA}$		0.29	0.33	V
V_F	$I_F=15\text{mA}$		0.40	0.45	V
V_F	$I_F=100\text{mA}$		0.74	1.00	V
C_T	$V_R=1.0\text{V}, f=1.0\text{MHz}$		7.0		pF
t_{rr}	$I_F=I_R=10\text{mA}, I_{rr}=1.0\text{mA}, R_L=100\Omega$			5.0	ns

CMFSH-3i
SURFACE MOUNT
DUAL, ISOLATED
SILICON SCHOTTKY DIODES



SOT-143 CASE - MECHANICAL OUTLINE

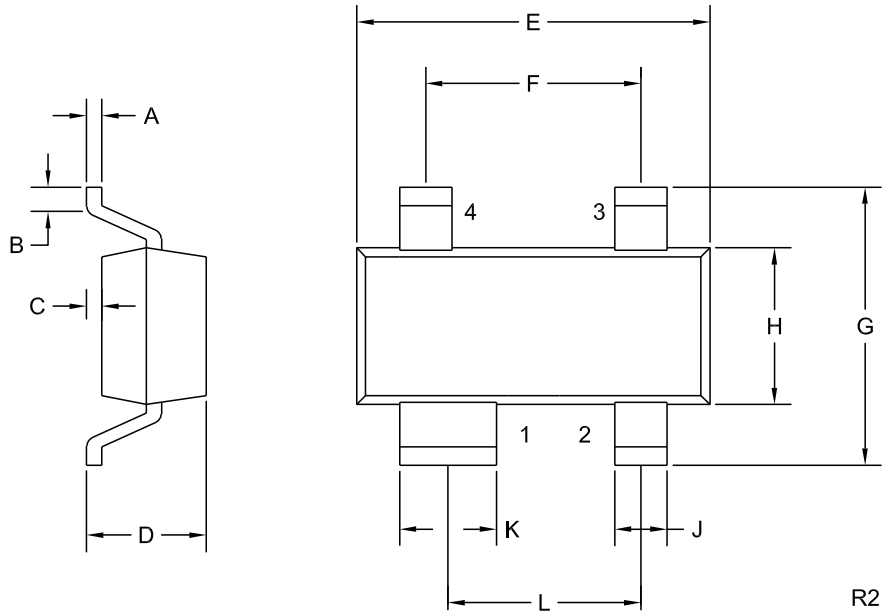

R2

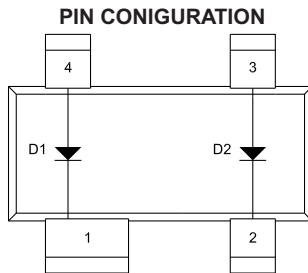

- LEAD CODE:**
 1) Cathode D1
 2) Cathode D2
 3) Anode D2
 4) Anode D1

MARKING CODE: C3I

SYMBOL	DIMENSIONS			
	INCHES		MILLIMETERS	
	MIN	MAX	MIN	MAX
A	0.003	0.006	0.08	0.15
B	0.006	-	0.15	-
C	-	0.005	-	0.13
D	-	0.045	-	1.14
E	0.110	0.120	2.79	3.04
F	0.075		1.90	
G	-	0.098	-	2.50
H	0.047	0.055	1.19	1.40
J	0.014	0.020	0.36	0.50
K	0.030	0.037	0.76	0.93
L	0.067		1.70	

SOT-143 (REV: R2)

R5 (13-August 2010)