

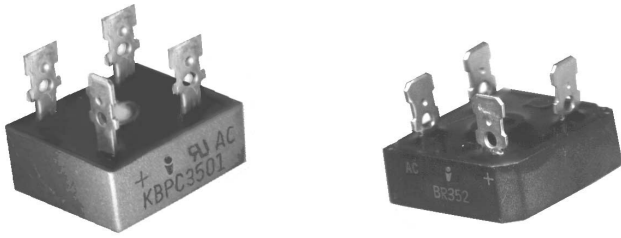

KBPC3500 / BR350 SERIES

35 AMPERE SINGLE-PHASE SILICON BRIDGE RECTIFIER



FEATURES

- High efficiency
- Surge overload rating - 400 amperes peak
- Body clad with metal (electrically isolated) or plastic
- Plastic encapsulation has Underwriters
- Laboratory flammability classification 94V-0
- Universal multi-purpose terminals

MECHANICAL DATA

Case : Metal or Plastic shell with plastic encapsulation

Terminals : 1/4 inch, 6.35mm Faston blades*

Polarity : Positive symbol printed on body

Weight : 1.1 ounce, 31.6 grams

VOLTAGE RANGE
50 to 1000 Volts PRV

CURRENT
35 Amperes

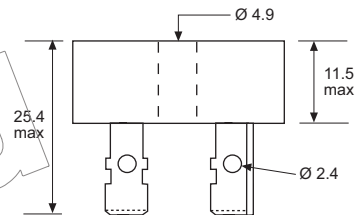
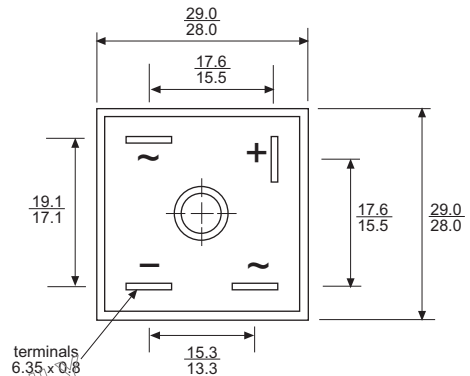

Dimensions in millimetres

MAXIMUM RATINGS AND ELECTRICAL CHARACTERISTICS

Ratings at 25°C ambient temperature unless otherwise specified. Single phase, half wave, 60 Hz, resistive or inductive load. For capacitive load, derate current by 20%.

		Metal Case	KBPC35005	KBPC3501	KBPC3502	KBPC3504	KBPC3506	KBPC3508	KBPC3510	
		Plastic Case	BR3505	BR351	BR352	BR354	BR356	BR358	BR3510	
Maximum Recurrent Peak Reverse Voltage	VRRM		50	100	200	400	600	800	1000	V
Maximum Bridge Input Voltage RMS	VRMS		35	70	140	280	420	560	700	V
Maximum DC Blocking Voltage	VDC		50	100	200	400	600	800	1000	V
Maximum Average Forward Current at T _c = 55 °C (see Fig 2)	IF(AV)		35.0							A
Peak Forward Surge Current, 8.3 ms single half sine - wave superimposed on rated load (see Fig 1)	IFSM		400							A
Maximum Forward Voltage Drop per Element at 17.5A (see Fig 3)	VF		1.2							V
Maximum Reverse Current at Rated DC Blocking Voltage per Element (see Fig 4) T _A = 25°C T _A = 100°C	IR		10.0 1.0							µA mA
RMS Isolation Voltage from Case to Terminals	VISO		2500							V
Typical Thermal Resistance	R _{θJC}		2.0							°C/w
Operating Temperature Range	T _J		- 55 to + 125							°C
Storage Temperature Range	T _{STG}		- 55 to + 150							°C

* Lead out wires can be supplied as an alternative to blades - add suffix W to part number e.g. KBPC3506W

RATING AND CHARACTERISTIC CURVES KBPC3500/BR350 SERIES

FIG 1 : MAXIMUM NON-REPETITIVE SURGE CURRENT PER ELEMENT

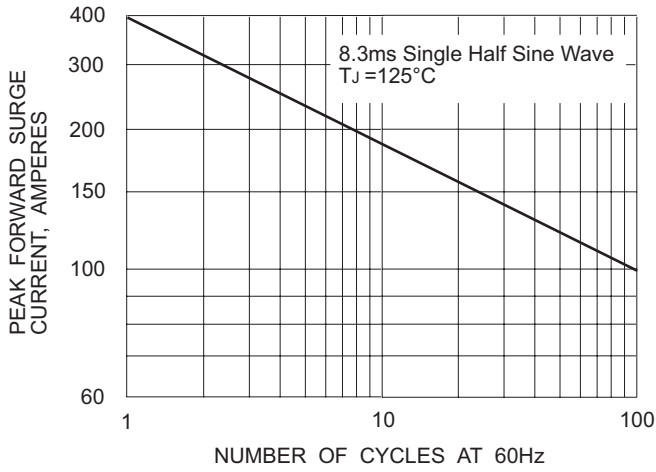

FIG 2 : DERATING CURVE FOR RECTIFIED OUTPUT CURRENT

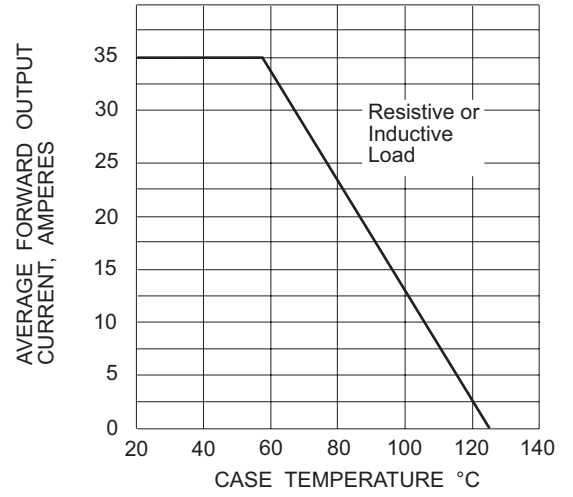

FIG 3 : TYPICAL FORWARD CHARACTERISTICS PER ELEMENT

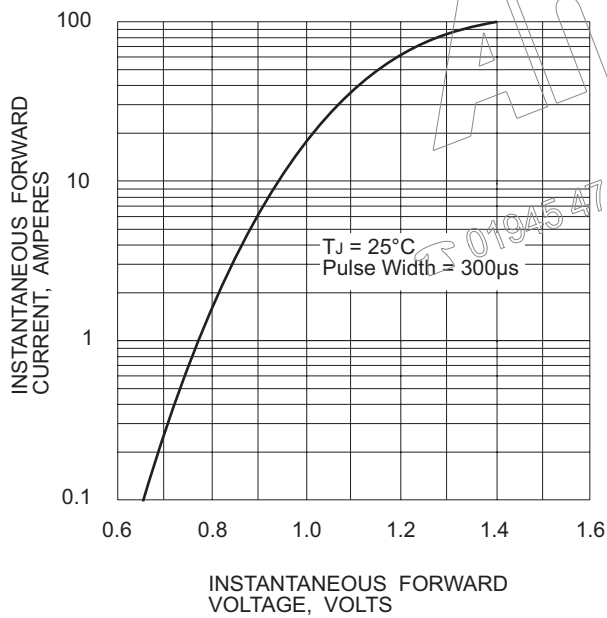

FIG 4 : TYPICAL REVERSE CHARACTERISTICS PER ELEMENT

