



# TMCM-142

**1-Axis  
Controller / Driver  
5A / 75V  
with Encoder Interface**

**INFO** The TMCM-142 is a high-performance single axis 2-phase stepper motor controller and driver with encoder feedback. It offers an aluminum U-shape profile for quick and robust mounting. The integrated TMC457 motion controller provides superior performance with regards to microstepping (up-to 1024), maximum velocity (integrated chopSync™ avoiding resonances), S-shape or linear ramp calculation in realtime and encoder feedback support (closing the loop in hardware with easyPID™ regulator). The driver stage supports motors with up-to 5A RMS coil current and offers exceptional low power dissipation. Its interface add-on board concept allows customer specific interface / connector solutions. The TMCM-142 comes with the PC based software development environment TMCL-IDE for the Trinamic Motion Control Language (TMCL). Using predefined TMCL high level commands like „move to position“ or „constant rotation“ rapid and fast development of motion control applications is guaranteed. The TMCL program can be stored in the on-board EEPROM for stand-alone operation.

### MAIN CHARACTERISTICS

- ELECTRICAL DATA**
  - up to 5A coil current RMS
  - 24V to 75V DC supply voltage
- SUPPORTED MOTORS**
  - two-phase bipolar stepper motors with 1A to 5A coil current
  - incremental encoder (2 or 3 channel, differential, open-collector or single ended)
- INTERFACE (WITH ADD ON-BOARD)**
  - RS232, RS485, RS422, USB or CAN 2.0b host
  - inputs for reference and stop switches (optically isolated)
  - general purpose analog and digital I/Os
- FEATURES**
  - high precision and high repeatability with encoder feedback and easyPID™ regulator
  - chopSync™ for high velocities
  - up-to 1024 times microstepping
  - memory for 2048 TMCL commands
  - motion profile calculation in hardware (RT)
  - trapezoid or S-shaped acceleration ramps
  - on the fly alteration of motion parameters
  - TRINAMIC driver technology: low power dissipation, no heatsink required
- SOFTWARE**
  - stand-alone operation using TMCL or remote controlled operation
  - PC-based application development software TMCL-IDE included
  - ready for CANopen
- OTHER**
  - RoHS compliant
  - size: 76 x 70 x 33 mm<sup>3</sup>

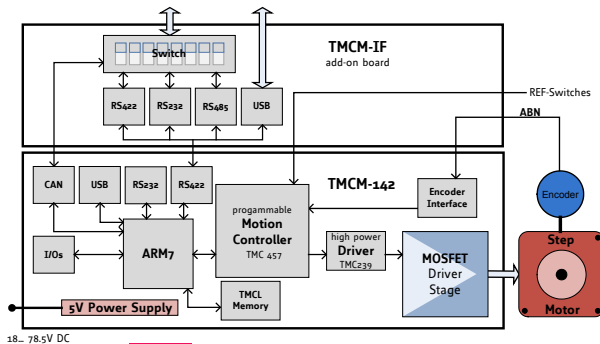

18... 78.5V DC

ORDER CODE	DESCRIPTION
<b>TMCM-142-IF (-opt.)</b>	1-axis controller / driver 5A / 75V with interface add-on board (standard)
<b>TMCM-142 (-option)</b>	1-axis controller / driver 5A / 75V (on request)
<b>OPTIONS</b>	
<b>TMCL</b>	TMCL firmware (standard)
<b>CANopen</b>	CANopen firmware (on request)