

Infrared Transceiver Module (FIR, 4 Mbit/s) for IrDA[®] combined with Remote Control Receiver (36 kHz to 38 kHz Carrier)

Description

The TFDU7100 IrDA compliant transceiver is a multimedia module that supports IrDA data transfer up to 4 Mbit/s (FIR) and bidirectional Remote Control operating over a range of more than 18 m. Integrated within the transceiver are two PIN photodiodes, an infrared emitter (IRED) and two low-power control IC. It is ideal for applications requiring both Remote Control and IrDA communication.

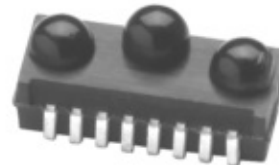

19584

Features

- Compliant to the latest IrDA physical layer specification (9.6 kbit/s to 4 Mbit/s)
- TV Remote Control receiver with 18 m receive range
- Remote Control carrier frequency 36 kHz to 38 kHz
- Operates from 2.7 V to 5.5 V within specification over full temperature range from - 25 °C to + 85 °C
- Surface Mount Package, low profile (L 9.9 mm x 4.1 mm x 4 mm)
- Compliant with IrDA Background Light Specification



- EMI Immunity > 300 V_{rms}/m in GSM Bands verified (according IEC61000-4-3)
- Lead (Pb)-free device
- Qualified for lead (Pb)-free and Sn/Pb processing (MSL4)
- Qualified for lead (Pb)-free and lead (Pb)-bearing soldering processes
- Device in accordance with RoHS 2002/95/EC and WEEE 2002/96/EC
- Split power supply, transmitter and receiver can be operated from two power supplies with relaxed requirements saving costs, US - Patent - No. 6,157,476

Applications

- Remote control and IrDA communication in Multimedia
- Notebook computers, Desktop PC's, Internet TV Boxes, Video Conferencing Systems
- Digital Still and Video Cameras
- Printers, fax machines, Photocopiers, Screen Projectors

Parts Table

Part	Description	Qty/Reel
TFDU7100-TR3	Oriented in carrier tape for side view surface mounting	1000 pcs
TFDU7100-TT3	Oriented in carrier tape for top view surface mounting	1000 pcs

Functional Block Diagram

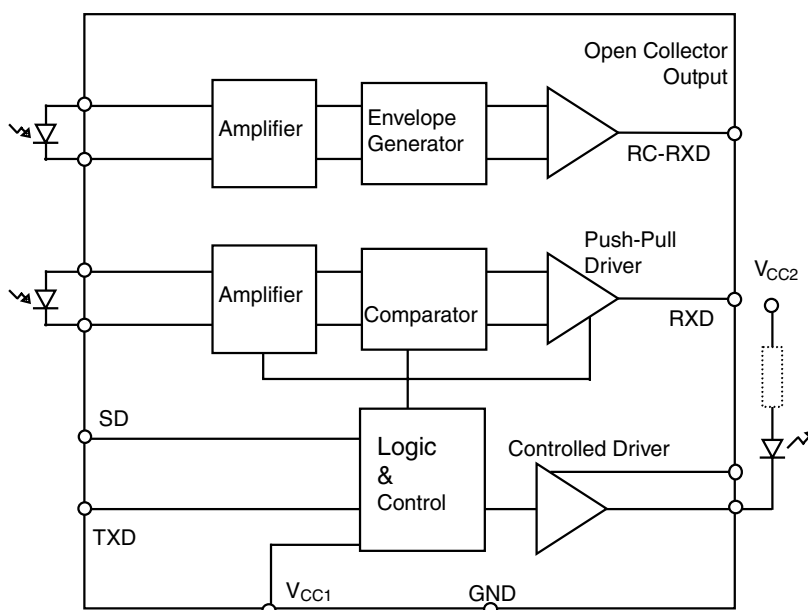

19597

Figure 1. Functional Block Diagram

Pin Description

Pin Number	Function	Description	I/O	Active
1	V _{CC2} IRED Anode	IRED anode to be externally connected to V _{CC2} . An external resistor is only necessary for controlling the IRED current when a current reduction below 300 mA is intended. This pin is allowed to be supplied from an uncontrolled power supply separated from the controlled V _{CC1} - supply		
2	IRED Cathode	IRED Cathode, internally connected to the driver transistor		
3	TXD	This Schmitt-Trigger input is used to transmit serial data when SD is low. An on-chip protection circuit disables the IRED driver if the TXD pin is asserted for longer than 80 μs.	I	HIGH
4	RXD	Received Data Output, push-pull CMOS driver output capable of driving standard CMOS or TTL loads. During transmission the RXD output is active (echo-on). No external pull-up or pull-down resistor is required. Floating with a weak pull-up of 500 kΩ (typ.) in shutdown mode.	O	LOW
5	SD	Shutdown for IRDA channel only	I	HIGH
6	V _{CC1}	Supply Voltage		
7	RC-RXD	Open Collector Output. This output is active during transmission (echo-on). External pull-up resistor to be added (e.g. 10 kΩ).	O	LOW
8	GND	Ground		



Absolute Maximum Ratings

Reference point Pin: GND unless otherwise noted.

Typical values are for DESIGN AID ONLY, not guaranteed nor subject to production testing.

Parameter	Test Conditions	Symbol	Min	Typ.	Max	Unit
Supply voltage range, transceiver	$-0.3\text{ V} < V_{CC2} < 6\text{ V}$	V_{CC1}	-0.5		+6.0	V
Supply voltage range, transmitter	$-0.5\text{ V} < V_{CC1} < 6\text{ V}$	V_{CC2}	-0.5		+6.0	V
Voltage at RXD	$-0.5\text{ V} < V_{CC1} < 6.0\text{ V}$	V_{RXD}	-0.5		$V_{CC1} + 0.5$	V
Voltage at all inputs and outputs	$V_{in} > V_{CC1}$ is allowed	V_{in}	-0.5		+6.0	V
Input currents	For all Pins, Except IRED Anode Pin				10	mA
Output sinking current					25	mA
Power dissipation	see derating curve	P_D			250	mW
Junction temperature		T_J			125	°C
Ambient temperature range (operating)		T_{amb}	-30		+85	°C
Storage temperature range		T_{stg}	-40		+100	°C
Soldering temperature	See recommended solder profile (see figure 5)				260	°C
Average output current, pin 1		$I_{IRED (DC)}$			125	mA
Repetitive pulse output current, pin 1 to pin 2	$< 0.3\ \mu\text{s}$, $t_{on} < 25\%$	$I_{IRED (RP)}$			700	mA
Virtual source size	Method: (1 - 1/e) encircled energy	d	2.5	2.8		mm
Maximum Intensity for Class 1	IEC60825-1 or EN60825-1, edition Jan. 2001, operating below the absolute maximum ratings	I_e			^{*)} (500) ^{**)}	mW/sr

^{*)} Due to the internal limitation measures the device is a "class1" device under all conditions.

^{**)} IrDA specifies the max. intensity with 500 mW/sr.

Definitions:

In the Vishay transceiver data sheets the following nomenclature is used for defining the IrDA operating modes:

SIR: 2.4 kbit/s to 115.2 kbit/s, equivalent to the basic serial infrared standard with the physical layer version IrPhy 1.0

MIR: 576 kbit/s to 1152 kbit/s

FIR: 4 Mbit/s

VFIR: 16 Mbit/s

MIR and FIR were implemented with IrPhy 1.1, followed by IrPhy 1.2, adding the SIR Low Power Standard. IrPhy 1.3 extended the Low Power Option to MIR and FIR and VFIR was added with IrPhy 1.4. A new version of the standard in any case obsoletes the former version. With introducing the updated versions the old versions are obsolete. Therefore the only valid IrDA standard is the actual version IrPhy 1.4 (in Oct. 2002).

Electrical Characteristics

Transceiver

Tested at $T_{amb} = 25\text{ }^{\circ}\text{C}$, $V_{CC1} = V_{CC2} = 2.7\text{ V}$ to 5.5 V unless otherwise noted.

Typical values are for DESIGN AID ONLY, not guaranteed nor subject to production testing.

Parameter	Test Conditions	Symbol	Min	Typ.	Max	Unit
Supply voltage		V_{CC1}	2.7		5.5	V
Dynamic supply current	SD = Low, $E_e = 1\text{ klx}^{**}$, V_{CC1}	I_{CC1}			5	mA
Average dynamic supply current, transmitting	$I_{IRED} = 300\text{ mA}$, 25 % Duty Cycle	I_{CC}			6.5	mA
Shutdown supply current ^{*)}	SD = High, $T = 25\text{ }^{\circ}\text{C}$, $E_e = 0\text{ klx}$	I_{SD}			2	mA
Operating temperature range		T_A	- 30		+ 85	$^{\circ}\text{C}$
Output voltage low, RXD	$C_{load} = 15\text{ pF}$	V_{OL}	- 0.5		$0.15 \times V_{CC1}$	V
Output voltage high, RXD	$I_{OH} = - 500\text{ }\mu\text{A}$ $I_{OH} = - 250\text{ }\mu\text{A}$, $C_{load} = 15\text{ pF}$	V_{OH}	$0.8 \times V_{CC1}$ $0.9 \times V_{CC1}$		$V_{CC1} + 0.5$	V V
RXD to V_{CC1} impedance		R_{RXD}	400	500	600	$\text{k}\Omega$
Input voltage low (TXD, SD)		V_{IL}	- 0.5		0.5	V
Input voltage high (TXD, SD)		V_{IH}	$V_{CC1} - 0.5$		6	V
Input leakage current (TXD, SD)	$V_{in} = 0.9 \times V_{logic}$	I_{ICH}	- 2		+ 2	μA
Controlled pull down current	SD, TXD = "0" or "1" $0 < V_{in} < 0.15 V_{CC1}$	I_{IRTX}			+ 150	μA
	SD, TXD = "0" or "1" $V_{in} > 0.7 V_{CC1}$	I_{IRTX}	- 1	0	1	μA
Input capacitance (TXD, SD)		C_I			5	pF

^{*)} The Remote Control receiver is always on. The shutdown function is used for disabling the IrDA channel, only

^{**)} Standard Illuminant A



Optoelectronic Characteristics

Receiver

Tested at $T_{amb} = 25\text{ }^{\circ}\text{C}$, $V_{CC1} = V_{CC2} = 2.7\text{ V}$ to 5.5 V unless otherwise noted.

Typical values are for DESIGN AID ONLY, not guaranteed nor subject to production testing.

Parameter	Test Conditions	Symbol	Min	Typ.	Max	Unit
Minimum detection threshold irradiance, SIR mode ^{*)}	9.6 kbit/s to 115.2 kbit/s $\lambda = 850\text{ nm} - 900\text{ nm}$ $\alpha = 0^{\circ}, 15^{\circ}$	E_e		45 (4.5)	81 (8.1)	mW/m^2 ($\mu\text{W}/\text{cm}^2$)
	576 kbit/s to 4 Mbit/s $\lambda = 850\text{ nm} - 900\text{ nm}$ $\alpha = 0^{\circ}, 15^{\circ}$	E_e		100 (10)	190 (19)	mW/m^2 ($\mu\text{W}/\text{cm}^2$)
Maximum irradiance in angular range ^{***)}	$\lambda = 850\text{ nm} - 900\text{ nm}$	E_e		5 (500)		kW/m^2 (mW/cm^2)
Logic LOEW receiver input irradiance	$\lambda = 850\text{ nm} - 900\text{ nm}$ $t_r, t_f < 40\text{ ns}$, $t_{po} = 1.6\text{ }\mu\text{s}$ at $f = 115\text{ kHz}$, no output signal allowed	E_e	4 (0.4)			mW/m^2 ($\mu\text{W}/\text{cm}^2$)
Rise time of output signal	10 % to 90 %, $C_L = 15\text{ pF}$	t_r (RXD)			40	ns
Fall time of output signal	90 % to 10 %, $C_L = 15\text{ pF}$	t_f (RXD)			40	ns
RXD pulse width of output signal, 50 % SIR Mode	Input pulse length $1.4\text{ }\mu\text{s} < P_{Wopt} < 25\text{ }\mu\text{s}$	t_{PW}		2.1		μs
	Input pulse length $1.4\text{ }\mu\text{s} < P_{Wopt} < 25\text{ }\mu\text{s}$ $- 25\text{ }^{\circ}\text{C} < T < 85\text{ }^{\circ}\text{C}$ ^{**))}	t_{PW}	1.5	1.8	2.6	μs
RXD pulse width of output signal, 50 % MIR mode	Input pulse length $P_{Wopt} = 217\text{ ns}$, 1.152 Mbit/s	t_{PW}	110	250	270	ns
RXD pulse width of output signal, 50 % FIR mode	Input pulse length $P_{Wopt} = 125\text{ ns}$, 4.0 Mbit/s	t_{PW}	100		140	ns
	Input pulse length $P_{Wopt} = 250\text{ ns}$, 4.0 Mbit/s	t_{PW}	225		275	ns
		t_{PW}	225		275	ns
Stochastic jitter, leading edge	$E_e = 200\text{ mW}/\text{m}^2$, 4 Mbit/s				20	ns
	$E_e = 200\text{ mW}/\text{m}^2$, 1.152 kbit/s				40	ns
	Input irradiance = $100\text{ mW}/\text{m}^2$, 576 kbit/s				80	ns
	$E_e = 200\text{ mW}/\text{m}^2$, $\leq 115.2\text{ kbit/s}$				350	ns
Receiver start-up time	After completion of shutdown programming sequence Power on delay				500	μs

^{*)} IrDA low power specification is $90\text{ mW}/\text{m}^2$. Spec takes a window loss 10 % into account.

^{**) IrDA sensitivity definition: Minimum Irradiance E_e In Angular Range, power per unit area. The receiver must meet the BER specification while the source is operating at the minimum intensity in angular range into the minimum half-angle range at the maximum Link Length.}

^{***) Maximum Irradiance E_e In Angular Range, power per unit area. The optical delivered to the detector by a source operating at the maximum intensity in angular range at Minimum Link Length must not cause receiver overdrive distortion and possible related link errors. If placed at the Active Output Interface reference plane of the transmitter, the receiver must meet its bit error ratio (BER) specification}

For more definitions see the document "Symbols and Terminology" on the Vishay Website (<http://www.vishay.com/docs/82512/82512.pdf>).

Remote Control Receiver^{*)}

Tested at $T_{amb} = 25\text{ °C}$, $V_{CC1} = V_{CC2} = 2.7\text{ V}$ to 5.5 V unless otherwise noted.
 Typical values are for DESIGN AID ONLY, not guaranteed nor subject to production testing

Parameter	Test Conditions	Symbol	Min	Typ.	Max	Unit
Minimum detection threshold irradiance _{RC}	$\lambda = 950\text{ nm}$ $\alpha = 0^\circ, 15^\circ, \text{RC5/RC6}, 36\text{ kHz}$	E_{eRC}		0.4 (0.04)		mW/m^2 ($\mu\text{W/cm}^2$)
Maximum detection threshold irradiance	$\lambda = 950\text{ nm}$ $\alpha = 0^\circ, 15^\circ, 36\text{ kHz}$ to 38 kHz	E_{eRC}		0.4 (0.04)	1	mW/m^2 ($\mu\text{W/cm}^2$)
Minimum detection threshold irradiance)	$\lambda = 850\text{ nm} - 970\text{ nm}$	E_{eRC}		0.4 (0.04)	2	mW/m^2 ($\mu\text{W/cm}^2$)
Maximum detection threshold irradiance	$\lambda = 850\text{ nm} - 900\text{ nm}$	E_{eRCmax}	30			W/m^2
Output voltage low, RC-RXD	$C_{Load} = 15\text{ pF}, R_L = 10\text{ k}\Omega^{**}$	V_{OLRC}	- 0.5		$0.15 \times V_{CC1}$	V
Output voltage high, RC-RXD	$C_{Load} = 15\text{ pF}, R_L = 10\text{ k}\Omega^{**}$	V_{HLRC}		V_{CC1}		V

^{*)} Timing parameters are equivalent to TSOP1238, see that datasheet.

^{**)} The RC-RXD output is an open collector output, therefore a load resistor is mandatory.

Optoelectronic Characteristics

Transmitter

Tested at $T_{amb} = 25\text{ °C}$, $V_{CC1} = V_{CC2} = 2.7\text{ V}$ to 5.5 V unless otherwise noted.
 Typical values are for DESIGN AID ONLY, not guaranteed nor subject to production testing

Parameter	Test Conditions	Symbol	Min	Typ.	Max	Unit
IRED operating current limitation	No external resistor for current limitation ^{*)}	I_D	450	550	650	mA
IRED operating current limitation for low power FIR mode	$V_{CC2} = 3.3\text{ V}, R_S = 18\ \Omega,$ $I_e \geq 10\text{ mW/sr}$	I_D		90		mA
Output leakage IRED current	$\text{TXD} = 0\text{ V}, 0 < V_{CC1} < 5.5\text{ V}$	I_{IRED}	- 1		1	μA
Output radiant intensity	$\alpha = 0^\circ, 15^\circ$, full IrDA cone, $\text{TXD} = \text{High}, \text{SD} = \text{Low}$, no external resistor for current limitation ^{*)}	I_e	50	70	300	mW/sr
	$\alpha = 0^\circ$ $\text{TXD} = \text{High}, \text{SD} = \text{Low}$, no external resistor for current limitation ^{*)}	I_e	80	200	400	mW/sr
	$V_{CC1} = 5.0\text{ V}, \alpha = 0^\circ, 15^\circ$ $\text{TXD} = \text{Low}$ or $\text{SD} = \text{High}$ (Receiver is inactive as long as $\text{SD} = \text{High}$)	I_e			0.04	mW/sr
Peak - emission wavelength ^{**)}		λ_p	880		900	nm
Spectral bandwidth		$\Delta\lambda$		45		nm
Optical rise time, fall time		t_{ropt}, t_{fopt}	10		40	ns
Optical output pulse duration	Input pulse width $1.63\ \mu\text{s}$, 115.2 kbit/s (SIR)	t_{opt}	1.6	1.63	1.75	μs
	Input pulse width 217 ns , 1.152 Mbit/s	t_{opt}	207	217	227	ns
	Input pulse width 125 ns , 4.0 Mbit/s	t_{opt}	117	125	133	ns
	Input pulse width 250 ns , 4.0 Mbit/s	t_{opt}	242	250	258	ns
	Input pulse width $0.1\ \mu\text{s}, < t_{TXD} < 100\ \mu\text{s}$	t_{opt}		t_{TXD}		μs
	Input pulse width $0.1\ \mu\text{s}, t_{TXD} \geq 100\ \mu\text{s}$	t_{opt}	t_{TXD}		100	μs
Optical overshoot					25	%

^{*)} Using an external current limiting resistor is allowed and recommended to reduce IRED intensity and operating current when current reduction is intended to operate at the IrDA low power conditions.
 E.g. for $V_{CC2} = 3.3\text{ V}$ a current limiting resistor of $R_S = 56\ \Omega$ will allow a power minimized operation at IrDA low power conditions.

^{**)} Note: Due to this wavelength restriction compared to the IrDA spec of 850 nm to 900 nm the transmitter is able to operate as source for the standard Remote Control applications with codes as e.g. Philips RC5/RC6[®] or RECS 80.

Recommended Circuit Diagram

Operated at a clean low impedance power supply the TFDU7100 needs no additional external components beside a resistor at the open collector RC-RXD-output. However, depending on the entire system design and board layout, additional components may be required (see figure 2).

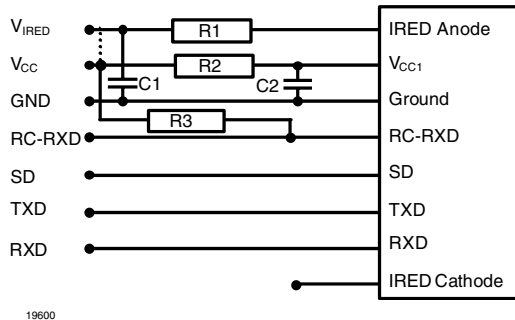

Figure 2. Recommended Application Circuit

The capacitor C1 is buffering the supply voltage and eliminates the inductance of the power supply line. This one should be a Tantalum or other fast capacitor to guarantee the fast rise time of the IRED current. The resistor R1 is the current limiting resistor, which may be used to reduce the operating current to levels below the specified controlled values for saving battery power.

Vishay's transceivers integrate a sensitive receiver and a built-in power driver. The combination of both needs a careful circuit board layout. The use of thin, long, resistive and inductive wiring should be avoided. The inputs (TXD, SD) and the output RXD should be directly (DC) coupled to the I/O circuit.

The capacitor C2 combined with the resistor R2 is the low pass filter for smoothing the supply voltage. R2, C1 and C2 are optional and dependent on the quality

of the supply voltages V_{CCx} and injected noise. An unstable power supply with dropping voltage during transmission may reduce the sensitivity (and transmission range) of the transceiver.

The placement of these parts is critical. It is strongly recommended to position C2 as close as possible to the transceiver power supply pins. An Tantalum capacitor should be used for C1 while a ceramic capacitor is used for C2.

In addition, when connecting the described circuit to the power supply, low impedance wiring should be used.

When extended wiring is used the inductance of the power supply can cause dynamically a voltage drop at V_{CC2} . Often some power supplies are not apply to follow the fast current rise time. In that case another $4.7 \mu\text{F}$ (type, see table under C1) at V_{CC2} will be helpful.

The RC-RXD output is an open collector driver. Therefore it needs an external pull-up resistor of e.g. $10 \text{ k}\Omega$ (R3).

Under extreme EMI conditions as placing an RF-transmitter antenna on top of the transceiver, we recommend to protect all inputs by a low-pass filter, as a minimum a 12 pF capacitor, especially at the RXD port. The transceiver itself withstands EMI at GSM frequencies above 500 V/m . When interference is observed, it is picked up by the wiring to the inputs. It is verified by DPI measurements that as long as the interfering RF - voltage is below the logic threshold levels of the inputs and equivalent levels at the outputs no interference is expected.

One should keep in mind that basic RF - design rules for circuit design should be taken into account. Especially longer signal lines should not be used without termination. See e.g. "The Art of Electronics" Paul Horowitz, Winfield Hill, 1989, Cambridge University Press, ISBN: 0521370957.

Recommended Application Circuit Components

Component	Recommended Value	Vishay Part Number
C1	$4.7 \mu\text{F}$, 16 V	293D 475X9 016B
C2	$0.1 \mu\text{F}$, Ceramic	VJ 1206 Y 104 J XXMT
R1	depends on current to be adjusted	
R2	47Ω , 0.125 W	CRCW-0805-47R
R3	$10 \text{ k}\Omega$, 0.125 W	CRCW-0805-10K

I/O and Software

In the description, already different I/Os are mentioned. Different combinations are tested and the function verified with the special drivers available from the I/O suppliers. In special cases refer to the I/O manual, the Vishay application notes, or contact directly Vishay Sales, Marketing or Application.

Mode Switching

The TFDU7100 is in the SIR mode after power on as a default mode, therefore the FIR data transfer rate has to be set by a programming sequence using the TXD and SD inputs as described below. The low frequency mode covers speeds up to 115.2 kbit/s. Signals with higher data rates should be detected in the high frequency mode. Lower frequency data can also be received in the high frequency mode but with reduced sensitivity.

To switch the transceivers from low frequency mode to the high frequency mode and vice versa, the programming sequences described below are required. The SD-pulse duration for programming should be limited to a maximum of 5 μ s avoiding that the transceiver goes into sleep mode.

Setting to the High Bandwidth Mode (0.576 Mbit/s to 4.0 Mbit/s)

1. Set SD input to logic "HIGH".
2. Set TXD input to logic "HIGH". Wait $t_s > 200$ ns.
3. Set SD to logic "LOW" (this negative edge latches state of TXD, which determines speed setting).
4. After waiting $t_h > 200$ ns TXD can be set to logic "LOW". The hold time of TXD is limited by the maximum allowed pulse length.

Table 2. Truth table

Inputs			Outputs		Remark
SD	TXD	Optical input Irradiance mW/m ²	RXD	Transmitter	RC-RXD
high	x	x	weakly pulled (500 k Ω to V _{CC1})	0	x
low	high	x	active low (echo)	I _e	x
low	high > 100 μ s	x	high	0	x
x	low	> specified RC sensitivity (RC-protocol)	x	0	active low (envelope)
low	low	< 4	high	0	x
low	low	> minimum irradiance in angular range (IrDA) < maximum irradiance in angular range (IrDA)	low (active)	0	x
low	low	> maximum irradiance in angular range (IrDA)	x	0	x

After that TXD is enabled as normal TXD input and the transceiver is set for the high bandwidth (576 kbit/s to 4 Mbit/s) mode.

Setting to the Lower Bandwidth Mode (2.4 kbit/s to 115.2 kbit/s)

1. Set SD input to logic "HIGH".
2. Set TXD input to logic "LOW". Wait $t_s > 200$ ns.
3. Set SD to logic "LOW" (this negative edge latches state of TXD, which determines speed setting).
4. TXD must be held for $t_h > 200$ ns.

After that TXD is enabled as normal TXD input and the transceiver is set for the lower bandwidth (9.6 kbit/s to 115.2 kbit/s) mode.

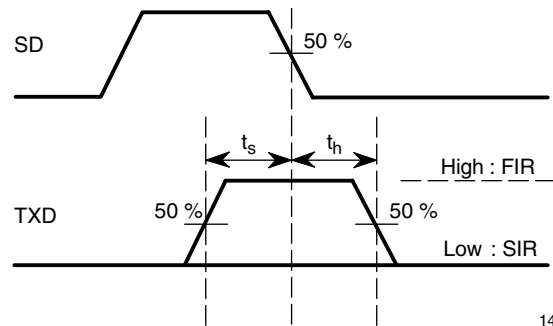

Figure 3. Mode Switching Timing Diagram

Recommended Solder Profiles

Solder Profile for Sn/Pb Soldering

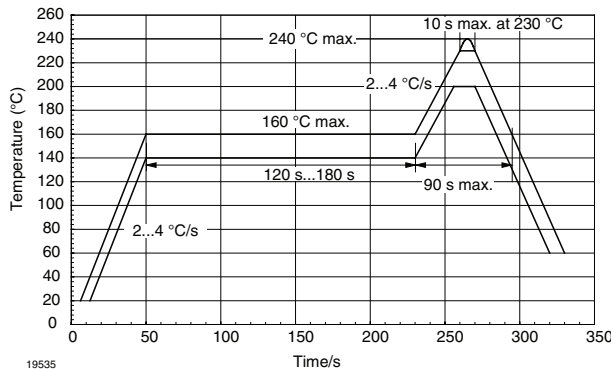

Figure 4. Recommended Solder Profile for Sn/Pb soldering

Lead (Pb)-Free, Recommended Solder Profile

The TFDU7100 is a lead (Pb)-free transceiver and qualified for lead (Pb)-free processing. For lead (Pb)-free solder paste like Sn (3.0 - 4.0) Ag (0.5 - 0.9) Cu, there are two standard reflow profiles: Ramp-Soak-Spike (RSS) and Ramp-To-Spike (RTS). The Ramp-Soak-Spike profile was developed primarily for reflow ovens heated by infrared radiation. With widespread use of forced convection reflow ovens the Ramp-To-Spike profile is used increasingly. Shown below in figure 5 and 6 are VISHAY's recommended profiles for use with the TFDU7100 transceivers. For more details please refer to the application note "SMD Assembly Instructions" (<http://www.vishay.com/docs/82602/82602.pdf>).

A ramp-up rate less than 0.9 °C/s is not recommended. Ramp-up rates faster than 1.3 °C/s could damage an optical part because the thermal conductivity is less than compared to a standard IC.

Wave Soldering

For TFDUxxx and TFBSxxx transceiver devices wave soldering is not recommended.

Manual Soldering

Manual soldering is the standard method for lab use. However, for a production process it cannot be recommended because the risk of damage is highly dependent on the experience of the operator. Nevertheless, we added a chapter to the above mentioned application note, describing manual soldering and desoldering.

Storage

The storage and drying processes for all VISHAY transceivers (TFDUxxx and TFBSxxx) are equivalent to MSL4.

The data for the drying procedure is given on labels

on the packing and also in the application note "Taping, Labeling, Storage and Packing" (<http://www.vishay.com/docs/82601/82601.pdf>).

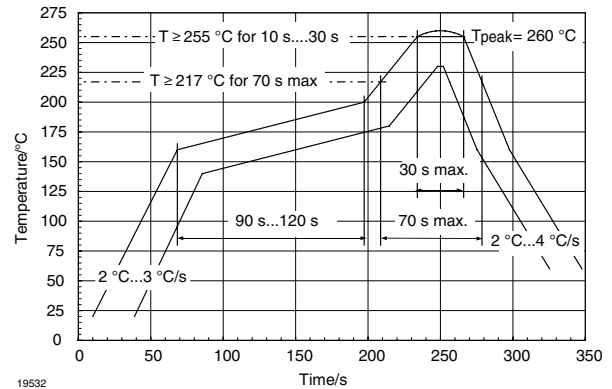

Figure 5. Solder Profile, RSS Recommendation

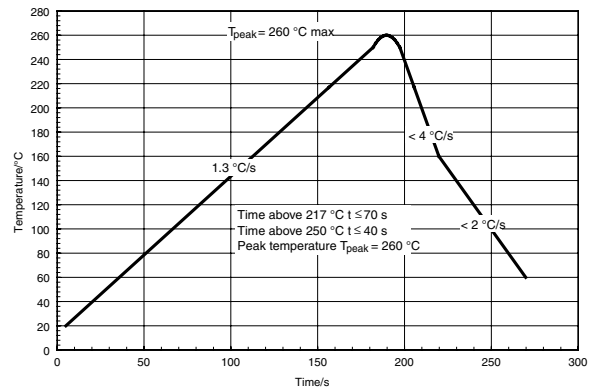

Figure 6. RTS Recommendation

Current Derating Diagram

Figure 7 shows the maximum operating temperature when the device is operated without external current limiting resistor.

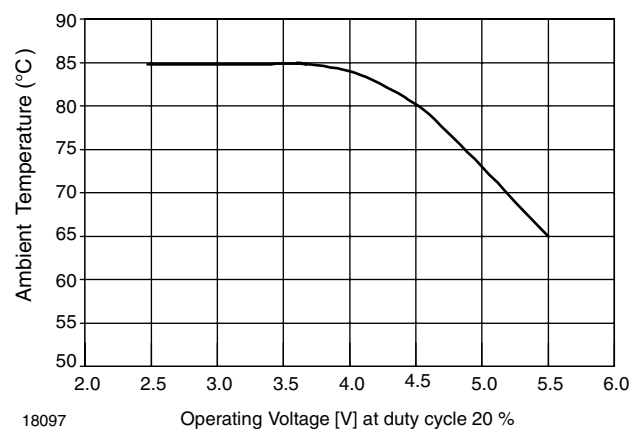

Figure 7. Current Derating Diagram

Optical Window

For the design of the optical windows see application note "Window Size in Housings"

TFDU7100 - (Universal) Package

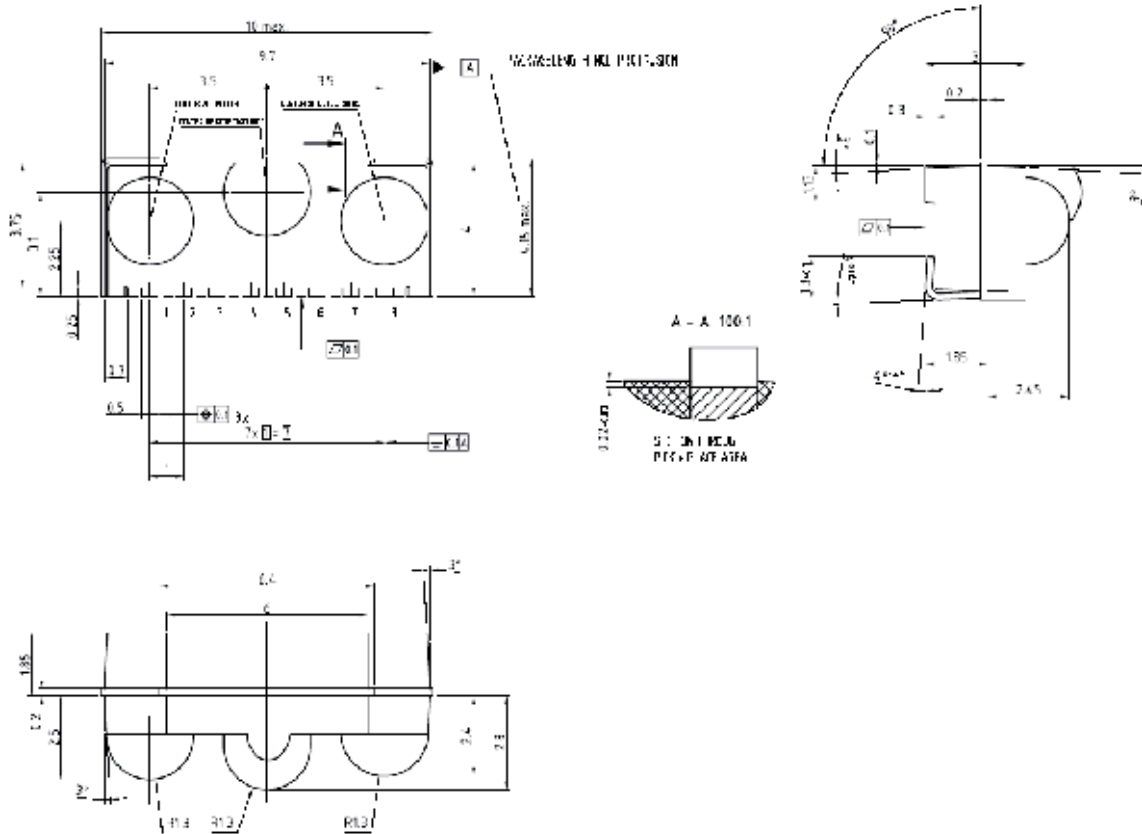

Figure 8. Package drawing TFDU7100, dimensions in mm, tolerance ± 0.2 if not otherwise mentioned

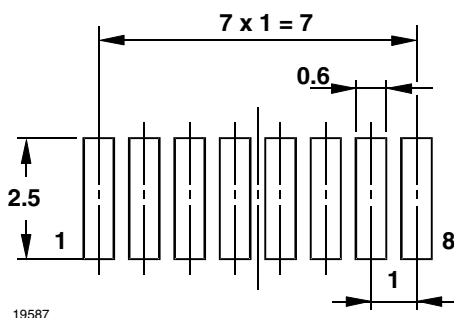
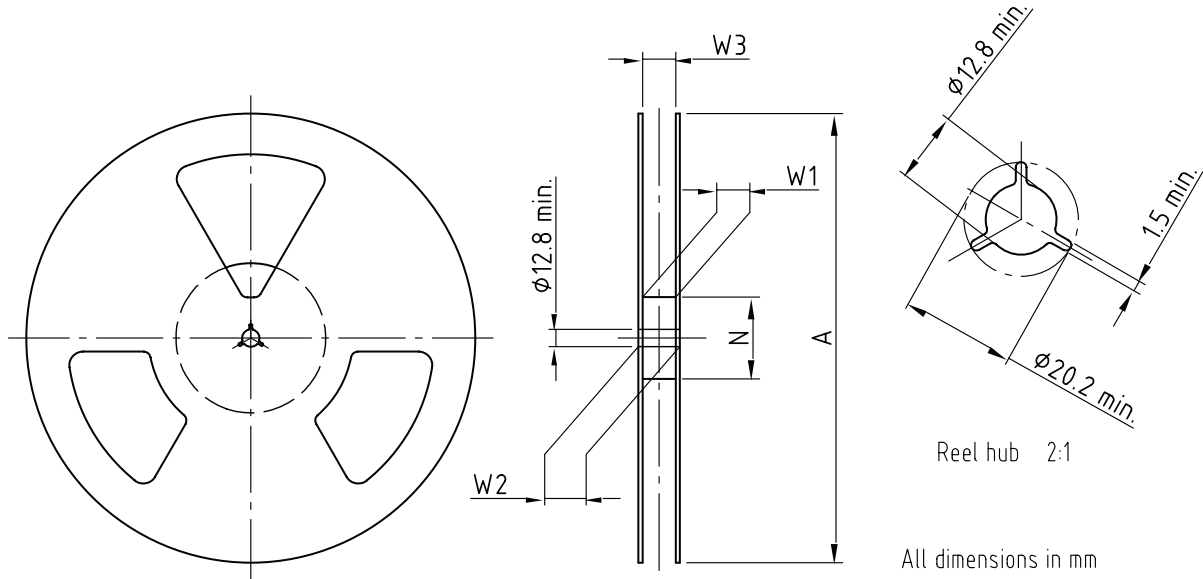

Figure 9. Recommended solder pad layout

Tape and Reel Reel dimensions



Drawing-No.: 9.800-5090.01-4
Issue: 1; 29.11.05
14017

Form of the leave open
of the wheel is supplier specific.

Dimension acc. to IEC EN 60 286-3

technical drawings
according to DIN
specifications

Figure 10. Reel dimensions, tolerance $\pm 0.2 \text{ mm}$, if not otherwise mentioned

Tape Width	A max.	N	W_1 min.	W_2 max.	W_3 min.	W_3 max.
mm	mm	mm	mm	mm	mm	mm
24	330	60	24.4	30.4	23.9	27.4

Tape Dimensions

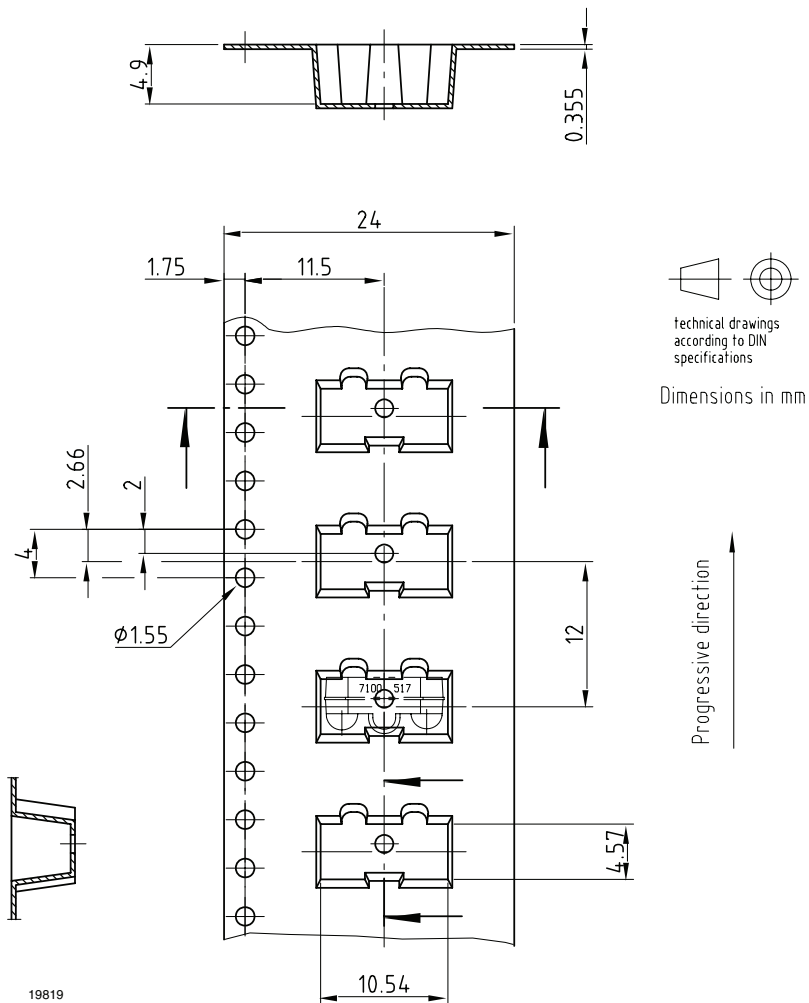

Drawing-No.: 9.700-5251.01-4
 Issue: 3; 02.09.05

Figure 11. Tape dimensions, tolerance ± 0.2 mm, if not otherwise mentioned



Ozone Depleting Substances Policy Statement

It is the policy of Vishay Semiconductor GmbH to

1. Meet all present and future national and international statutory requirements.
2. Regularly and continuously improve the performance of our products, processes, distribution and operating systems with respect to their impact on the health and safety of our employees and the public, as well as their impact on the environment.

It is particular concern to control or eliminate releases of those substances into the atmosphere which are known as ozone depleting substances (ODSs).

The Montreal Protocol (1987) and its London Amendments (1990) intend to severely restrict the use of ODSs and forbid their use within the next ten years. Various national and international initiatives are pressing for an earlier ban on these substances.

Vishay Semiconductor GmbH has been able to use its policy of continuous improvements to eliminate the use of ODSs listed in the following documents.

1. Annex A, B and list of transitional substances of the Montreal Protocol and the London Amendments respectively
2. Class I and II ozone depleting substances in the Clean Air Act Amendments of 1990 by the Environmental Protection Agency (EPA) in the USA
3. Council Decision 88/540/EEC and 91/690/EEC Annex A, B and C (transitional substances) respectively.

Vishay Semiconductor GmbH can certify that our semiconductors are not manufactured with ozone depleting substances and do not contain such substances.

We reserve the right to make changes to improve technical design
and may do so without further notice.

Parameters can vary in different applications. All operating parameters must be validated for each customer application by the customer. Should the buyer use Vishay Semiconductors products for any unintended or unauthorized application, the buyer shall indemnify Vishay Semiconductors against all claims, costs, damages, and expenses, arising out of, directly or indirectly, any claim of personal damage, injury or death associated with such unintended or unauthorized use.

Vishay Semiconductor GmbH, P.O.B. 3535, D-74025 Heilbronn, Germany



Notice

Specifications of the products displayed herein are subject to change without notice. Vishay Intertechnology, Inc., or anyone on its behalf, assumes no responsibility or liability for any errors or inaccuracies.

Information contained herein is intended to provide a product description only. No license, express or implied, by estoppel or otherwise, to any intellectual property rights is granted by this document. Except as provided in Vishay's terms and conditions of sale for such products, Vishay assumes no liability whatsoever, and disclaims any express or implied warranty, relating to sale and/or use of Vishay products including liability or warranties relating to fitness for a particular purpose, merchantability, or infringement of any patent, copyright, or other intellectual property right.

The products shown herein are not designed for use in medical, life-saving, or life-sustaining applications. Customers using or selling these products for use in such applications do so at their own risk and agree to fully indemnify Vishay for any damages resulting from such improper use or sale.