



Spec. No.	PS-ND-0807
Rev.	A

# PRODUCT SPECIFICATION

**Model No : CSS-816B7/815B7**

## Descriptions:

- 0.80 Inch Single Digit Display
- Emitting Color : Super Bright Blue



CUSTOMER APPROVED	APPROVED BY	CHECKED BY	PREPARED BY
SIGNATURES			陳新強

CHINA SEMICONDUCTOR CORPORATION  
Address:2FL. NO.909,Chung-Cheng Road,  
Chung-Ho City Taipei Hsien,Taiwan.

Tel:886-2-2223-9696  
Fax:886-2-2223-9377

OPTO PLUS TECHNOLOGIES CO.,LTD  
Address:696 Shun jiang Rd.,Ji Shan St.Shaoxing,  
ZheJiang,China

Tel:86-0575-88623888  
Fax:86-0575-88623112



Spec. No.	PS-ND-0807
Rev.	A

**Model No : CSS-816B7/815B7**

**Features -**

1. 0.80 inch (20.4mm) digit height.
2. Case mold type.
3. RoHS compliant.
4. Low power consumption.
5. ESD>1KV(HBM)
6. Easy mounting on P.C. board or socket.

**Device Selection Guide -**

Part No.	Chip		Description
	Material	Emitted Color	
CSS-816B7	InGaN	Super Bright Blue	Common Anode
CSS-815B7	InGaN	Super Bright Blue	Common Cathode

**Mechanical Dimensions -**

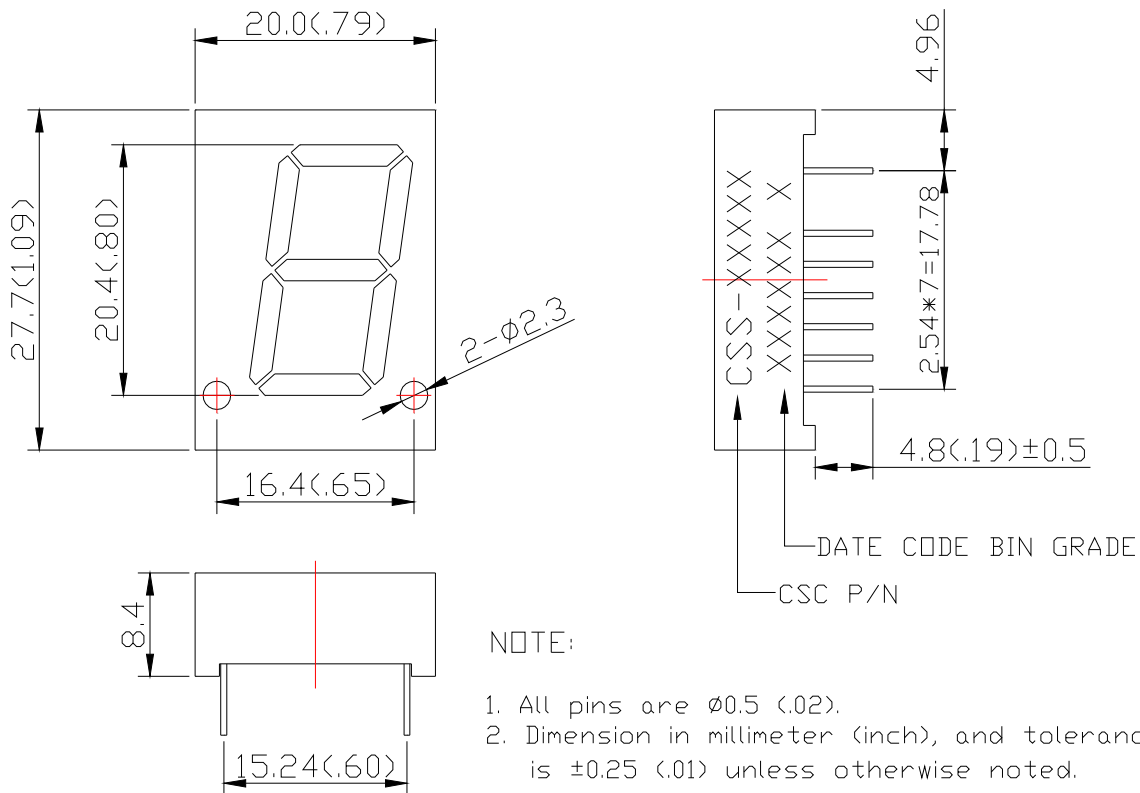

**NOTE:**

1. All pins are φ0.5 (0.02).
2. Dimension in millimeter (inch), and tolerance is ±0.25 (0.01) unless otherwise noted.



Model No : CSS-816B7/815B7

Internal Circuit Diagrams -

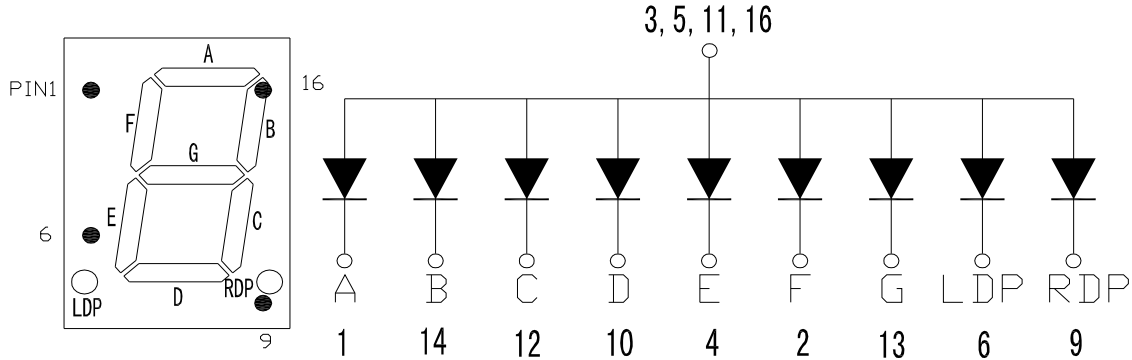

NO. 7,8,15 No PIN  
CSS-816 Common Anode  
(CSS-815 Common Cathode.)

Absolute Maximum Rating -

(Ta=25°C)

Parameter	Symbol	Rating	Unit
Power Dissipation Per Dice	Pd	120	mW
Continuous Forward Current Per Dice	IAF	30	mA
Peak Current Per Dice	IPF	100	mA
Derating Linear From 25°C Per Dice	-	0.4	mA/°C
Reverse Voltage Per Dice	VR	5	V
Operating Temperature	Topr	-35 ~ +85	°C
Storage Temperature	Tstg	-35 ~ +85	°C
Solder temperature 1/16 inch below seating plane for 3 seconds at 260 °C			



Model No : CSS-816B7/815B7

■ Electro-optical Characteristics -

(Ta=25°C)

Parameter	Symbol	Min.	Typ.	Max.	Unit	Condition
Forward Voltage Per Segment	VF	-	3.5	4	V	IF=20mA
Luminous Intensity Per Segment	Iv	6400	16000	-	ucd	IF=10mA
Peak Emission Wavelength	$\lambda P$	-	468	-	nm	IF=20mA
Dominant Wavelength	$\lambda d$	-	470	-	nm	IF=20mA
Spectrum Radiation Bandwidth	$\Delta \lambda$	-	20	-	nm	IF=20mA
Reverse Current	IR	-	-	100	$\mu A$	VR=5V
Luminous Intensity Matching Ratio	IV-m	-	-	2:1	-	IF=10mA



**Model No : CSS-816B7/815B7**

**Typical Electrical / Optical Characteristics Curves -**

**(Ta = 25°C Unless Otherwise Noted)**

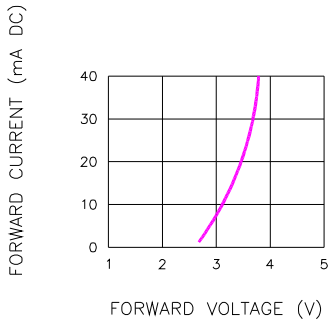

Fig.1 FORWARD CURRENT VS. FORWARD VOLTAGE

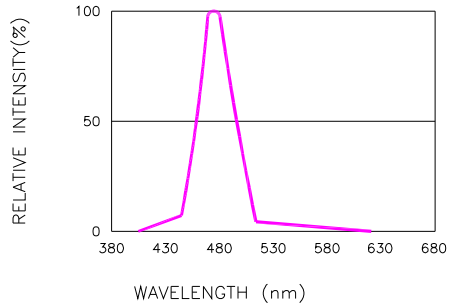

Fig.2 RELATIVE INTENSITY VS. WAVELENGTH

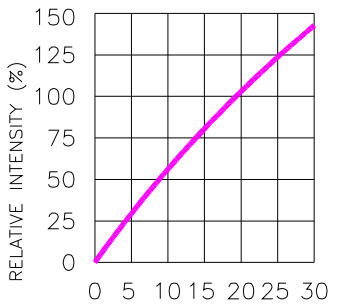

Fig.3 RELATIVE INTENSITY VS. FORWARD CURRENT

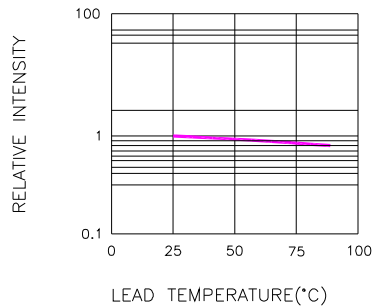

Fig.4 RELATIVE INTENSITY VS. LEAD TEMPERATURE  
(PULSED 20 mA; 300us PULSE, 10ms PERIOD)

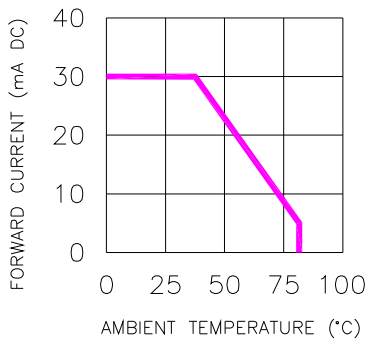

Fig.5 FORWARD CURRENT VS. AMBIENT TEMPERATURE

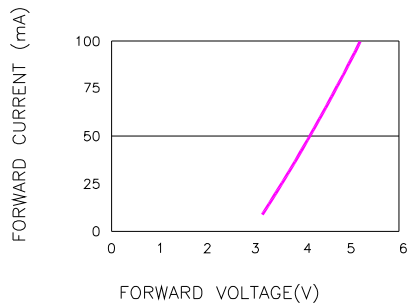

Fig.6 PEAK FORWARD VOLTAGE VS. FORWARD (100us TEST PULSE, 1% DUTY CYCLE)



Spec. No.	PS-ND-0807
Rev.	A

Model No : CSS-816B7/815B7

### ■ Package Dimensions

Single Digit Display  
Dice Code  
CSS-81XX

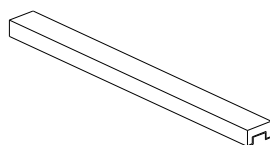

18 PCS per tube

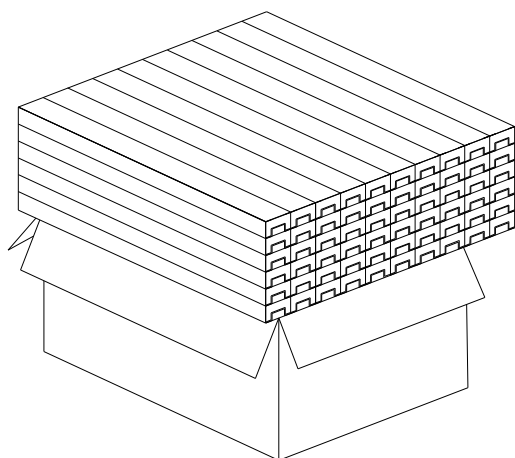

60 Tubes per inner box  
Total Q'TY: 1080 pcs

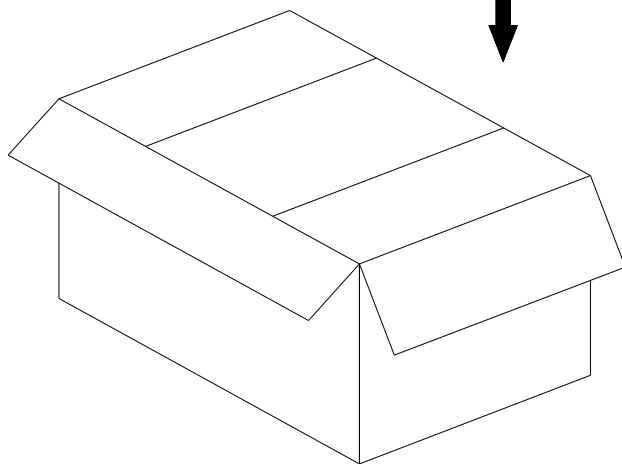

3 Inner boxes per carton.  
Total Q'TY: 3240 pcs

Carton size:  
L54xW48.5xH30.5cm

Note: The specifications are subject to change without notice. Please contact us for updated information.

<http://www.csctw.com.tw>