

晶采光電科技股份有限公司
AMPIRE CO., LTD.

SPECIFICATIONS FOR LCD MODULE

CUSTOMER	
CUSTOMER PART NO.	
AMPIRE PART NO.	AC-202DYILY-06H-A(R)
APPROVED BY	
DATE	

AMPIRE CO., LTD.

**TOWER A, 4F, No.114, Sec. 1, HSIN-TAI 5th RD., HIS-CHIH,
TAIPEI HSIEN, TAIWAN(R.O.C.)**

台北縣汐止鎮新台五路一段114號4樓(東方科學園區A棟)

TEL:886-2-26967269, FAX:886-2-26967196 or 886-2-26967270

APPROVED BY	CHECKED BY	ORGANIZED BY

RECORD OF REVISION

Revision Date	Page	Contents	Editor
2006/4/27	-	New Release	Lorry

1 FEATURES

- (1) Display format : 20 characters × 2 lines
- (2) Construction : LCD, Black Bezel, Zebra, LED back-light and PCB.
- (3) Display type: STN Yellow-Green mode, Transflective, 6 o' clock, Positive
- (4) Controller : ST7066U-0T.
- (5) Besides +5V for logic circuit, -5V is needed for LCD driving.
- (6) Extended temperature type.
- (7) ROHS compliant.

2 MECHANICAL DATA

Parameter	Stand Value	Unit
Dot size	1.10(W) × 1.50(H)	mm
Dot pitch	1.20(W) × 1.60(H)	mm
Character size	5.9(W) × 12.7(H)	mm
Viewing area	147.0(W) × 35.2(H)	mm
Module size (w/ LED back-light)	182.0(W) × 60.0(H) × 14.0max (T))	mm

3 ABSOLUTE MAXIMUM RATINGS

Parameter	Symbol	Min	Max	Unit	
Logic Circuit Supply Voltage	VDD-VSS	0	7.0	V	
LCD Driving Voltage	VDD-VO	0	16	V	
Input Voltage	VI	VSS	VDD	V	
Extended temp. type	Operating Temp.	TOP	-20	70	°C
	Storage Temp.	TSTG	-30	80	°C

4 ELECTRO-OPTICAL CHARACTERISTICS

Parameter	Symbol	Condition	Min	Typ	Max	Unit	Note
----- Electronic Characteristics -----							
Logic Circuit Supply Voltage	VDD-VSS	--	4.5	5.0	5.5	V	
LCD Driving Voltage	VDD-VO	-20 °C	8.0	8.5	9.0	V	
		25 °C	8.0	8.5	9.0		
		70 °C	8.0	8.5	9.0		
Input Voltage	VIH	--	0.7 VDD	--	VDD	V	
	VIL	--	VSS	--	0.3 VDD	V	
Logic Supply Current	IDD	VDD = 5V	--	1.2	1.7	mA	
----- Optical Characteristics -----							
Contrast	CR	25	--	5	--		Note 1
Rise Time	tr	25°C	--	200	300	ms	Note 2
Fall Time	tf	25°C	--	200	300	ms	
Viewing Angle Range	θ f	25°C & CR≥2	--	40	--	Deg.	Note 3
	θ b		--	35	--		
	θ l		--	35	--		
	θ r		--	35	--		
Frame Frequency	fF	25°C	--	64	--	Hz	
----- LED Back-light Characteristics -----							
Forward Voltage	VF	--	--	4.05	4.3	V	Supply Voltage between A&K
Forward Current	IF	VF=4.05V	--	420	--	mA	
LCM Luminous intensity		VF=4.05V	--	35	--	cd/m ²	

* LED Dice number = 2×42=84

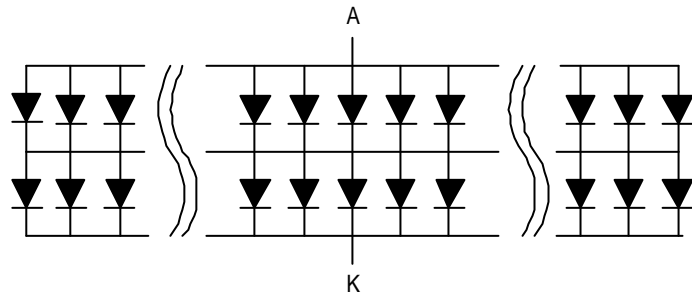

(NOTE 1) Contrast ratio :

CR = (Brightness in OFF state) / (Brightness in ON state)

(NOTE 2) Response time :

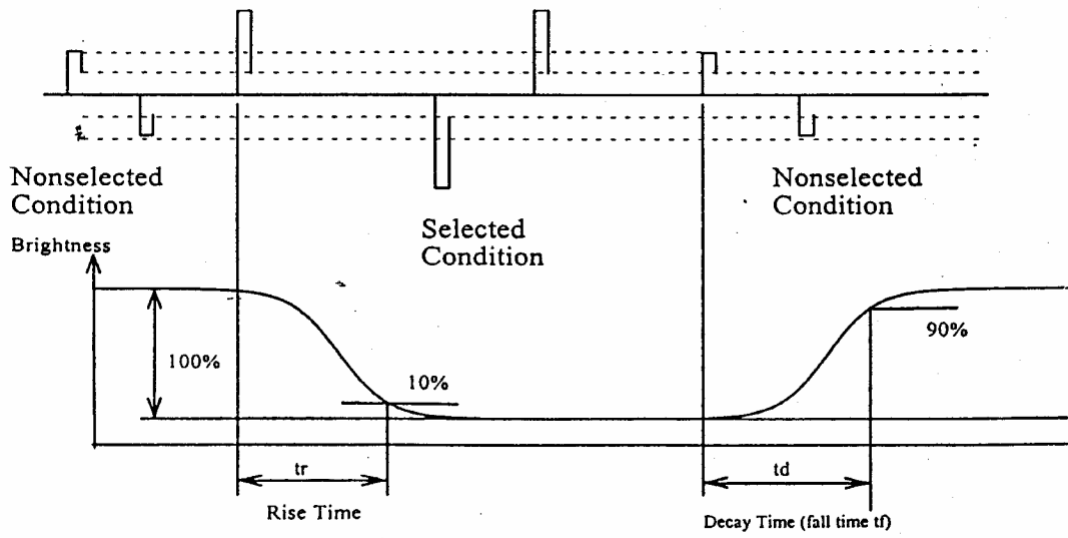

(NOTE 3) Viewing angle

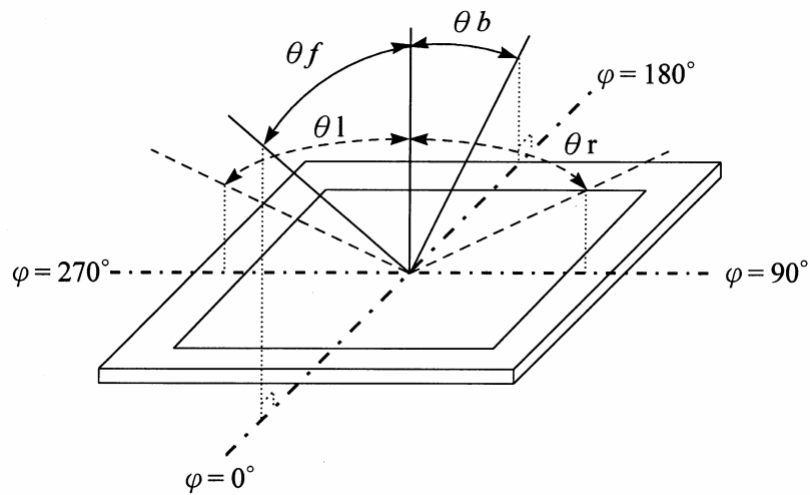

5 BLOCK DIAGRAM & INTERFACE

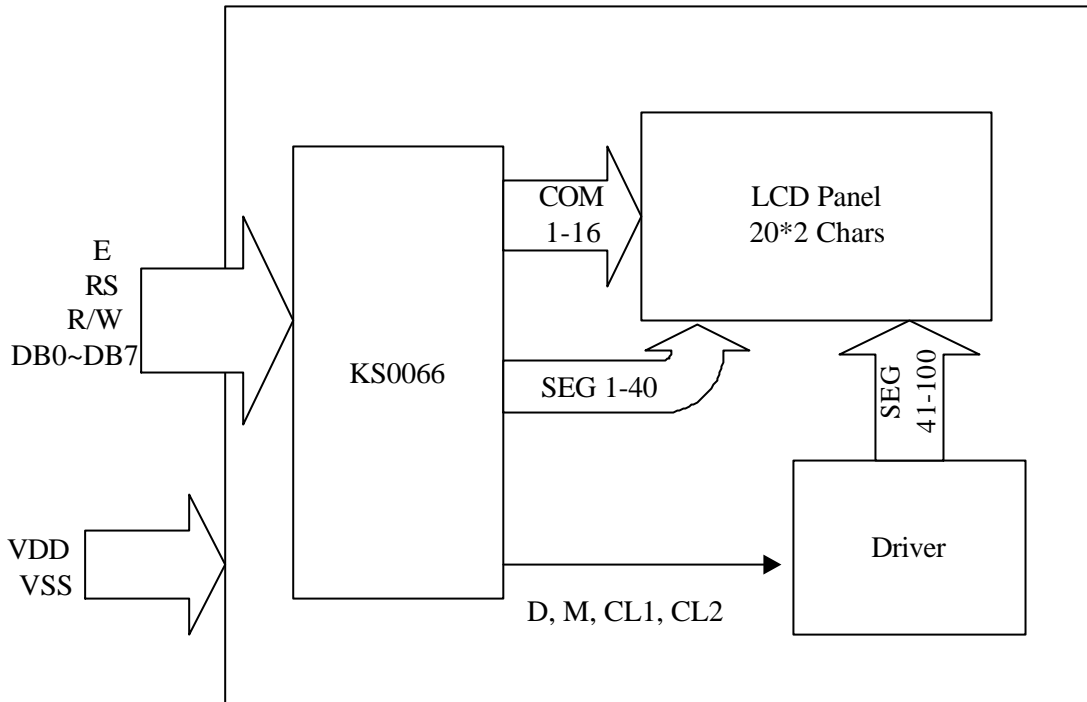

No.	Symbol	Function
1	VSS	Ground (0V)
2	VDD	Supply Voltage for Logic (+5V)
3	VO	Contrast Adjustment
4	RS	Data/Instruction Select
5	R/W	Read/Write Select
6	E	Enable Signal
7	DB0	Data Bus
8	DB1	Data Bus
9	DB2	Data Bus
10	DB3	Data Bus
11	DB4	Data Bus
12	DB5	Data Bus
13	DB6	Data Bus
14	DB7	Data Bus
15	LED_A	LED Power Supply + (4.2V)
16	LED_K	LED Power Supply - (4.2V)

6 POWER SUPPLY

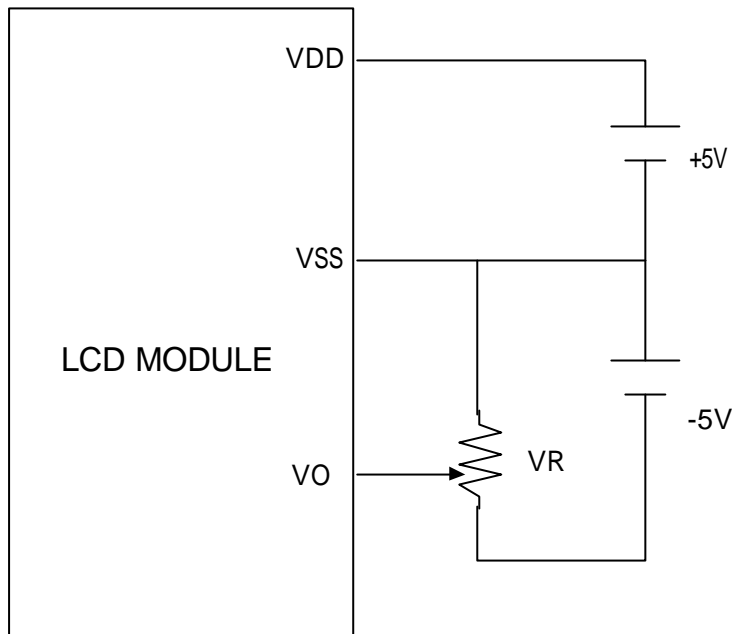

VDD-VO: LCD Driving Voltage

7 TIMING CHARACTERISTICS

Write Operation

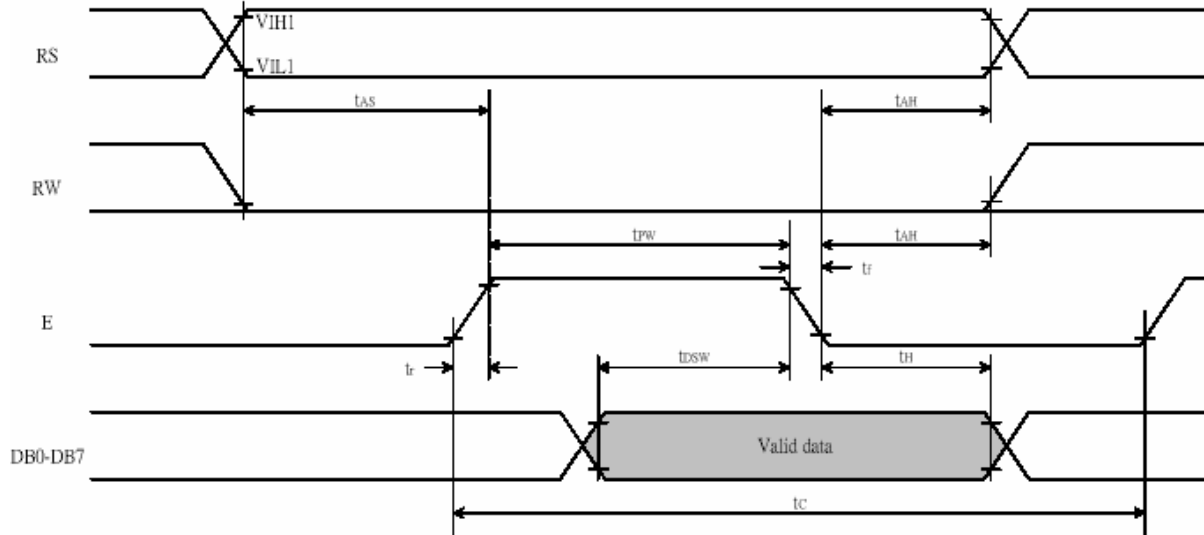

Item	Symbol	Min	Typ	Max	Unit
Enable cycle time	Tc	1200	-	-	ns
Enable pulse width (high level)	Tpw	460	-	-	
Enable rise/fall time	Tr, Tf	-	-	25	
Address set-up time (RS, R/W to E)	TAS	0	-	-	
Address hold time	TAH	10	-	-	
Data set-up time	TDSW	80	-	-	
Data hold time	TH	10	-	-	

Read Operation

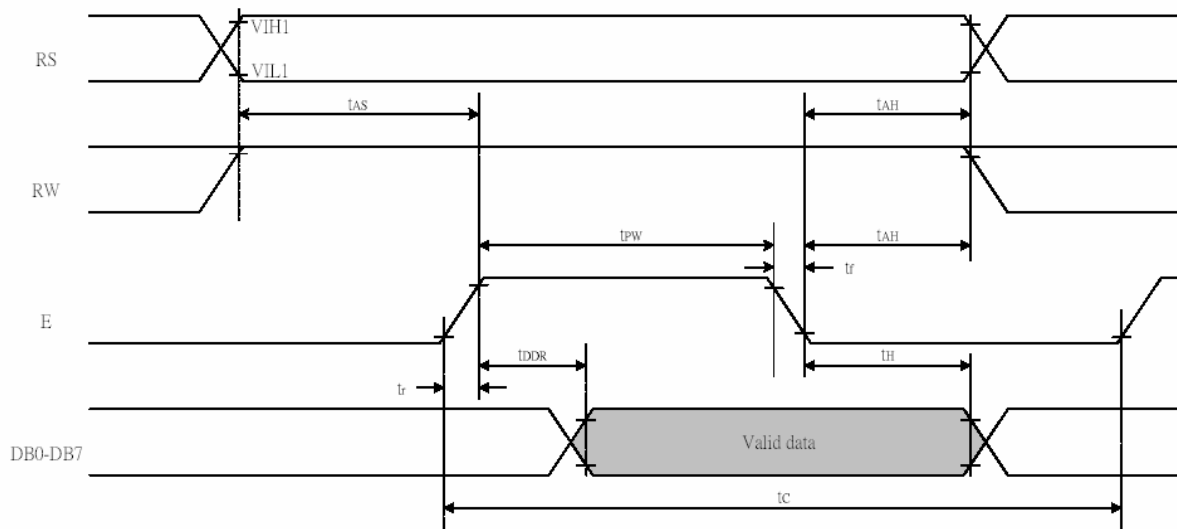

Item	Symbol	Min	Typ	Max	Unit
Enable cycle time	Tc	1200	-	-	ns
Enable pulse width (high level)	Tpw	480	-	-	
Enable rise/fall time	Tr, Tf	-	-	25	
Address set-up time (RS, R/W to E)	TAS	0	-	-	
Address hold time	TAH	10	-	-	
Data delay time	TDSW	--	-	320	
Data hold time	TH	10	-	-	

8 INSTRUCTION SET

Instruction	Code										Description	E.T.(fosc =250 KHZ)	
	RS	R/ W	D7	D6	D5	D4	D3	D2	D1	D0			
Clear Display	0	0	0	0	0	0	0	0	0	1	Write "20H" to DDRAM and set DDRAM address to "00H" from AC	1.52ms	
Return Home	0	0	0	0	0	0	0	0	0	1	--	Sets DD RAM address to "00H" from AC and return cursor to its original position if shifted. The contents of DDRAM are not changed.	1.52ms
Entry Mode SET	0	0	0	0	0	0	0	0	1	I/D	SH	Assign cursor moving direction and enable the shift of entire display.	37 μS
Display ON/OFF Control	0	0	0	0	0	0	0	1	D	C	B	Set display (D), cursor (C), and blink of cursor (B) on/off control bit.	37 μS
Cursor or Display Shift	0	0	0	0	0	1	S/ C	R/ L	--	--	--	Set cursor moving and display shift control bit, and the direction, without changing of DDRAM data.	37 μS
Function Set	0	0	0	0	1	DL	N	F	--	--	--	Sets interface data length (DL:8-bit/4-bit), number of display lines (N:2-line/1-line) and , display font type (F:5x11dots/5x8 dost).	37 μS
Set CG RAM Address	0	0	0	1	AC 5	AC 4	AC 3	AC 2	AC 1	AC 0	AC 0	Sets CG RAM address in address counter.	37 μS
Set DD RAM Address	0	0	1	AC 6	AC 5	AC 4	AC 3	AC 2	AC 1	AC 0	AC 0	Sets DD RAM address in address counter.	37 μS
Read Busy Flag and Address	0	1	BF	AC 6	AC 5	AC 4	AC 3	AC 2	AC 1	AC 0	AC 0	Whether during internal operation or not can be known by reading BF. The contents of address counter can also be read.	37 μS
Write Data to RAM	1	0	D7	D6	D5	D4	D3	D2	D1	D0	D0	Writes data into internal RAM (DD RAM /CG RAM).	37 μS
Read Data from RAM	1	1	D7	D6	D5	D4	D3	D2	D1	D0	D0	Reads data from internal RAM (DD RAM /CG RAM).	37 μS

* "--" : don't care

Note : When an MPU program with checking the Busy Flag(DB7) is made, it must be necessary 1/2Fosc is necessary for executing the next instruction by the falling edge of the 'E' signal after the Busy Flag(DB7) goes to "LOW".

9 INITIALIZATION SEQUENCE

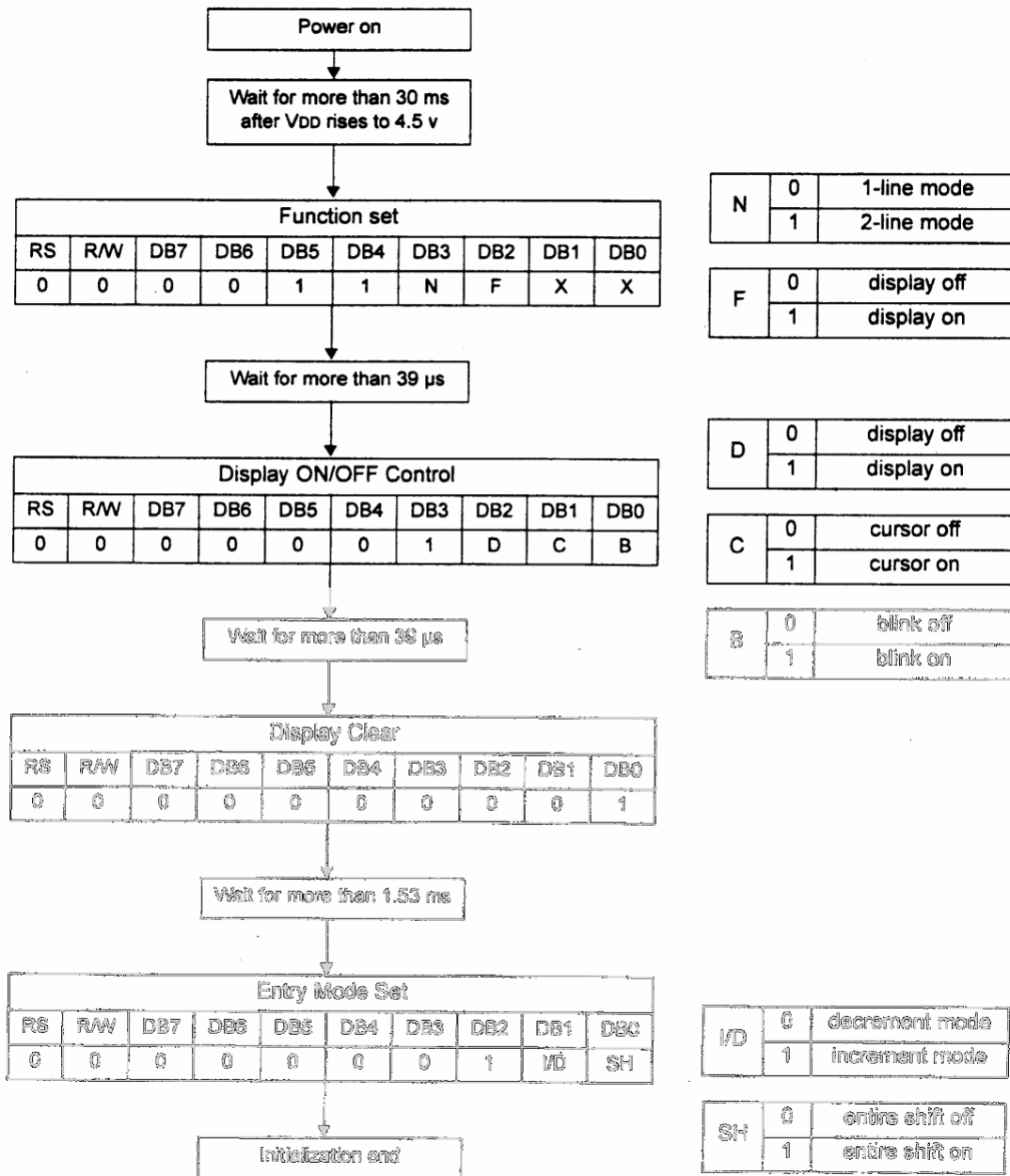

10 DD RAM ADDRESS

CHAR.	1	2	3	...	18	19	20
1 LINE	00	01	02	...	11	12	13
2 LINE	40	41	42	...	51	52	53

11 FONT TABLE

№. 7066-0T

b7-b4 b3-b0	0000	0001	0010	0011	0100	0101	0110	0111	1000	1001	1010	1011	1100	1101	1110	1111
0000	CG RAM (1)			0	1	2	3	4			В	В	Ч	.	Д	Ж
0001	(2)		!	1	А	В	а	в			Г	Я	Ш	.	Ц	Щ
0010	(3)		"	2	В	В	б	в			Е	Е	Ь	У	Ш	Щ
0011	(4)		#	3	С	С	с	с			Ж	В	И	И	А	А
0100	(5)		\$	4	Д	Т	д	т			Э	Г	Ь	Ъ	Ф	В
0101	(6)		%	5	Е	У	е	у			И	Е	Э	Х	Ц	Г
0110	(7)		&	6	Ф	У	ф	у			Й	Ж	Ю	Ъ	Щ	Ъ
0111	(8)		^	7	Г	В	г	в			Л	Э	Я	И	'	Е
1000	(1)		(8	Н	Х	н	х			П	И	О	И	'	†
1001	(2))	9	И	У	и	у			У	А	О	†	'	‡
1010	(3)		* :	J	Z	J	Z				Ф	К	„	↓	€	‡
1011	(4)		+ :	K	L	k	l				Ч	л	”	М	С	†
1100	(5)		,	<	L	Ф	l	е			Ш	М	”	М	У	‡
1101	(6)		- =	M	I	и	и	Б			Ь	Н	С	М	‡	‡
1110	(7)		.	>	N	^	n	e			Ы	п	ф	Ъ	О	¶
1111	(8)		/	?	O	L	o	e			Э	Т	Е	•	О	■

12 QUALITY AND RELIABILITY

12.1 TEST CONDITIONS

Tests should be conducted under the following conditions :

Ambient temperature : $25 \pm 5^{\circ}\text{C}$

Humidity : $60 \pm 25\% \text{ RH}$.

12.2 SAMPLING PLAN

Sampling method shall be in accordance with MIL-STD-105E , level II, normal single sampling plan .

12.3 ACCEPTABLE QUALITY LEVEL

A major defect is defined as one that could cause failure to or materially reduce the usability of the unit for its intended purpose. A minor defect is one that does not materially reduce the usability of the unit for its intended purpose or is an infringement from established standards and has no significant bearing on its effective use or operation.

12.4 APPEARANCE

An appearance test should be conducted by human sight at approximately 30 cm distance from the LCD module under fluorescent light. The inspection area of LCD panel shall be within the range of following limits.

12.5 INSPECTION QUALITY CRITERIA

Item	Description of defects			Class of Defects	Acceptable level (%)
Function	Short circuit or Pattern cut			Major	0.65
Dimension	Deviation from drawings			Major	1.5
Black spots	Ave . dia . D	area A	area B	Minor	2.5
	$D \leq 0.2$	Disregard			
	$0.2 < D \leq 0.3$	3	4		
	$0.3 < D \leq 0.4$	2	3		
	$0.4 < D$	0	1		
Black lines	Width W, Length L	A	B	Minor	2.5
	$W \leq 0.03$	disregard			
	$0.03 < W \leq 0.05$	3	4		
	$0.05 < W \leq 0.07, L \leq 3.0$	1	1		
	See line criteria				
Bubbles in polarizer	Average diameter D $0.2 < D < 0.5$ mm for N = 4 , D > 0.5 for N = 1			Minor	2.5
Color uniformity	Rainbow color or newton ring.			Minor	2.5
Glass Scratches	Obvious visible damage.			Minor	2.5
Contrast ratio	See note 1			Minor	2.5
Response time	See note 2			Minor	2.5
Viewing angle	See note 3			Minor	2.5

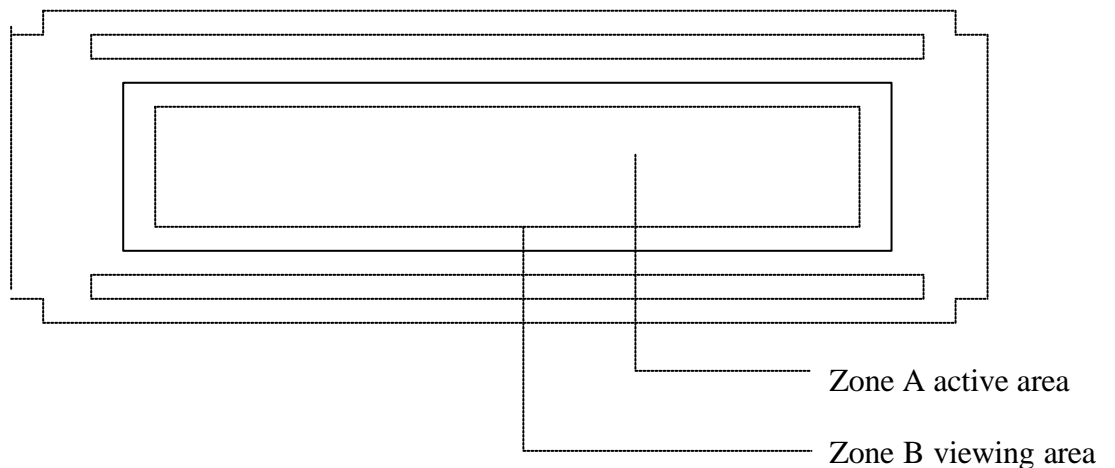

12.6 RELIABILITY

Test Item	Test Conditions	Note
High Temperature Operation	70±3°C , t=96 hrs	
Low Temperature Operation	-20±3°C , t=96 hrs	
High Temperature Storage	80±3°C , t=96 hrs	1,2
Low Temperature Storage	-30±3°C , t=96 hrs	1,2
Temperature Cycle	-30°C (30 min.) ~ 25°C (5 min.) ~ 80°C (30 min.) (1 cycle) Total 5 cycle	1,2
Humidity Test	40 °C, Humidity 90%, 96 hrs	1,2
Vibration Test (Packing)	Sweep frequency : 10 ~ 55 ~ 10 Hz/1min Amplitude : 0.75mm Test direction : X.Y.Z/3 axis Duration : 30min/each axis	2

Note 1 : Condensation of water is not permitted on the module.

Note 2 : The module should be inspected after 1 hour storage in normal conditions
(15-35°C , 45-65%RH).

Definitions of life end point :

- Current drain should be smaller than the specific value.
- Function of the module should be maintained.
- Appearance and display quality should not have degraded noticeably.
- Contrast ratio should be greater than 50% of the initial value.

13 HANDLING PRECAUTIONS

- (1) A LCD module is a fragile item and should not be subjected to strong mechanical shocks.
- (2) Avoid applying pressure to the module surface. This will distort the glass and cause a change in color.
- (3) Under no circumstances should the position of the bezel tabs or their shape be modified.
- (4) Do not modify the display PCB in either shape or positioning of components.
- (5) Do not modify or move location of the zebra or heat seal connectors.
- (6) The device should only be soldered to during interfacing. Modification to other areas of the board should not be carried out.
- (7) In the event of LCD breakage and resultant leakage of fluid do not inhale, ingest or make contact with the skin. If contact is made rinse immediately.
- (8) When cleaning the module use a soft damp cloth with a mild solvent, such as Isopropyl or Ethyl alcohol. The use of water, ketone or aromatic is not permitted.
- (9) Prior to initial power up input signals should not be applied.
- (10) Protect the module against static electricity and observe appropriate anti-static precautions.

14 OUTLINE DIMENSION

