

Description

ACE1117 series of high performance low dropout voltage regulators are designed for applications that require efficient conversion and fast transient response.

In addition, ACE1117 is designed to be stable under conditions where C_{in} and C_{out} are not present. However, it is recommended to include C_{in} and C_{out} in the system design as this will speed up the transient response and increase the PSRR rating.

Features

- Low Dropout Performance.
- Low Quiescent Current: 3mA (Typ.)
- Guaranteed 1A Output Current.
- Wide input Supply Voltage Range.
- Stable operation without C_{in} and C_{out} .
- Over-temperature and Over-current Protection
- Fixed or Adjustable Output Voltage.
- Rugged 2KV ESD withstand capability.
- Available in SOT-223 and TO-252 Packages.
- RoHS Compliant and 100% Lead (Pb)-Free

Application

- Active SCSI Terminators
- High Efficiency Linear Regulators
- 5V to 3.3V Linear Regulators
- Motherboard Clock Supplies

Absolute Maximum Ratings

Parameter	Symbol	Max	Unit
Input voltage	V_{IN}	9	V
Junction temperature	T_J	-40 to 130	$^{\circ}C$
Thermal Resistance Junction to Ambient	θ_{JA}	60	$^{\circ}C/W$
Storage temperature	T_s	- 40 to 150	$^{\circ}C$

Packaging Type

SOT-223

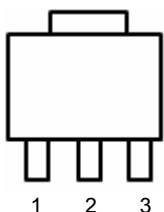

TO-252

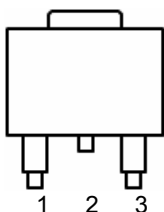

Pin	Symbol
1	ADJ/GND
2	Vout
3	Vin

Ordering information

Selection Guide

ACE1117 XX XX + H

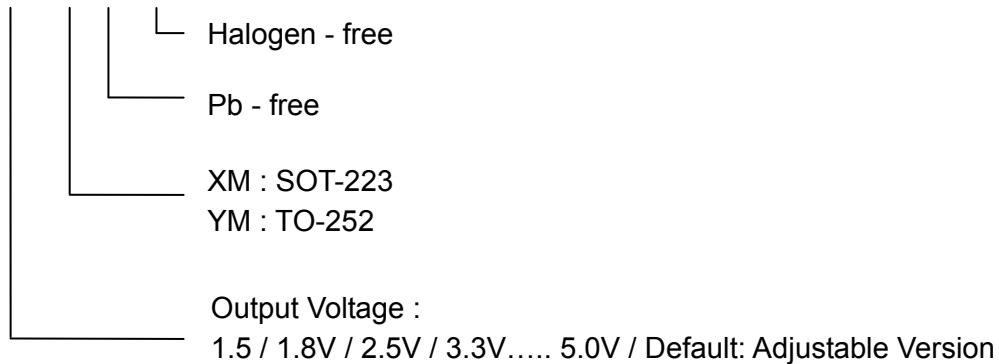

Electrical Characteristics

$V_{IN,MAX} \leq 8V$, $V_{IN,MAX} - V_{OUT} = 1.5V$, $I_{OUT} = 10mA$, $C_{IN} = 10\mu F$, $C_{OUT} = 22\mu F$, $T_A = 25^\circ C$, unless otherwise specified.

Parameter	Symbol	Test Conditions	Min	Typ	Mum	Unit
Output Voltage ⁽¹⁾	V_O	ACE1117-15	1.470	1.5	1.530	V
		ACE1117-18	1.764	1.8	1.836	
		ACE1117-25	2.450	2.5	2.550	
		ACE1117-33	3.234	3.3	3.366	
		ACE1117-50	4.900	5.0	5.100	
Reference Voltage ⁽¹⁾ (ADJ. Voltage Version)	V_{REF}	$(V_{IN} - V_{OUT}) = 1.5V$ $I_{OUT} = 10mA$	(-2%)	1.250	(+2%)	V
Line Regulation ⁽¹⁾	V_{SR}	$V_{OUT} + 1.5V < V_{IN} < 8V$ $I_{OUT} = 10mA$		0.3		%
Load Regulation ⁽¹⁾	V_{LR}	$(V_{IN} - V_{OUT}) = 1.5V$ $10mA \leq I_{OUT} \leq 1A$		0.5		%
Quiescent Current ⁽²⁾	I_Q	Fixed Output Version		3		mA
Adjust Pin Current	I_{ADJ}			65		uA
Adjust Pin Current Change	ΔI_{ADJ}	$V_{OUT} + 1.5V < V_{IN} < 8V$ $10mA \leq I_{OUT} \leq 1A$		14		uA
Dropout Voltage ⁽³⁾	V_D	$I_{OUT} = 1A$		1.3		V
Minimum Load Current	I_o			0.4		mA
Current Limit	I_{CL}			1.8		A
Temperature Coefficient	T_C			0.07		%/ $^\circ C$
Thermal Protection	OTP			175		$^\circ C$
RMS Output Noise	V_N	$T_A = 25^\circ C$, $10Hz \leq f \leq 100kHz$		0.003		% V_O
Ripple Rejection Ratio	R_A	$f = 120Hz$, $C_{OUT} = 22\mu F$ (Tantalum), $(V_{IN} - V_{OUT}) = 3V$, $I_{OUT} = 10mA$		55		dB

Note1: Low duty cycle pulse testing with which T_J remains unchanged.

2: The I_Q of ACE1117-1.5 is 1.2mA (Typ.)

3: The dropout voltage is the input/output differential at which the circuit ceases to regulate against further reduction in input

Typical Application

Adjustable Voltage Regulator

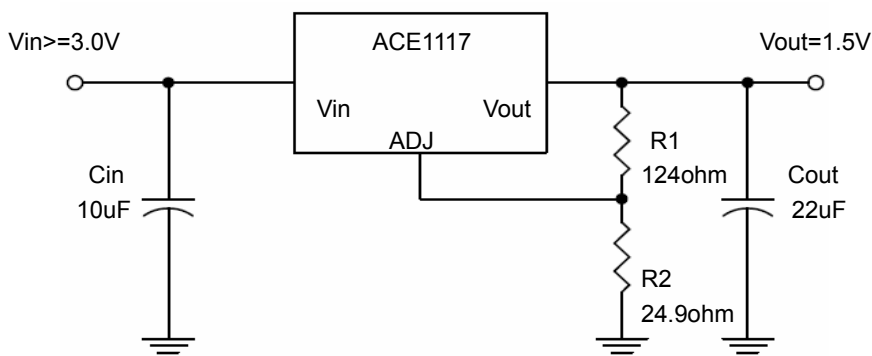

$$V_{OUT} = V_{REF} * (1 + R2/R1) + I_{ADJ} * R2$$

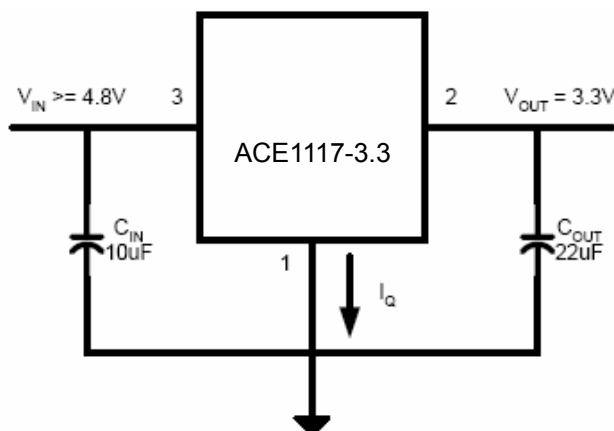

Fixed Voltage Regulator

Application Hints

The typical Linear regulator would require external capacitors to ensure stability. However, ACE1117 is designed in such a way that these external capacitor can be omitted if the PCB layout is tight and system noise is not very high. For better transient and PSRR performance, the Input and Output capacitors are still recommended.

Input Capacitor

An input capacitor of 10 μ F is recommended. Ceramic or Tantalum can be used. The value can be increased without upper limit.

Output Capacitor

An output capacitor of 22uF is recommended for better transient and PSRR performance. It should be placed no more than 1 cm away from the V_{OUT} pin, and connected directly between V_{OUT} and GND pins. The value may be increased without upper limit.

Thermal Considerations

It is important that the thermal limit of the package is not exceeded. The ACE1117 has built-in thermal protection. When the thermal limit is exceeded, the IC will enter protection, and V_{OUT} will be pulled to ground. The power dissipation for a given application can be calculated as following:

$$\text{The power dissipation (P}_D\text{) is } P_D = I_{OUT} * [V_{IN} - V_{OUT}]$$

The thermal limit of the package is then limited to $P_{D(MAX)} = [T_J - T_A]/\Theta_{JA}$ where T_J is the junction temperature, T_A is the ambient temperature, and Θ_{JA} is around 180°C/W for ACE1117. ACE1117 is designed to enter thermal protection at 175°C. For example, if T_A is 25°C then the maximum PD is limited to about 0.83W. In other words, if $I_{OUT(MAX)} = 500\text{mA}$, then $[V_{IN} - V_{OUT}]$ can not exceed 1.66V. (Ref. SOT-223 without heat sink.)

Typical Performance Characteristic

Reference Voltage vs Junction Temperature

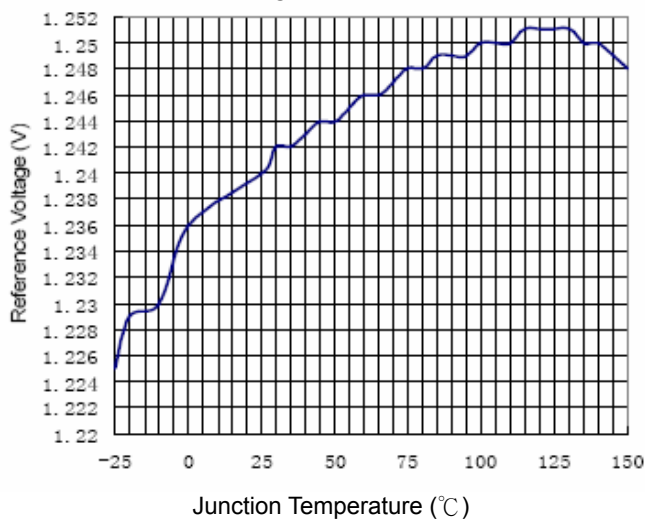

Output Voltage vs Junction Temperature

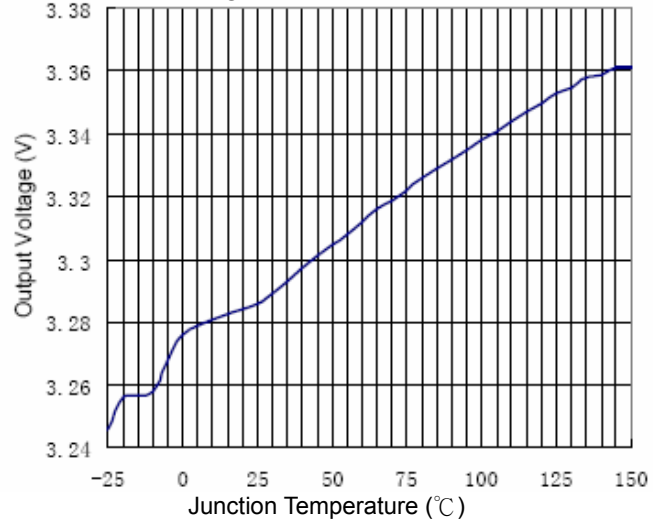

Dropout Voltage vs Output Current

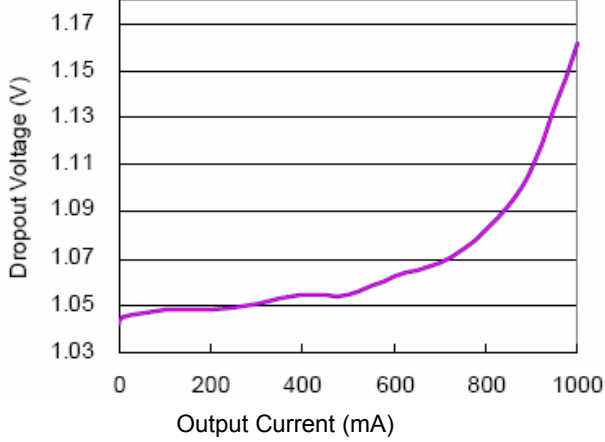

PSRR vs Frequency

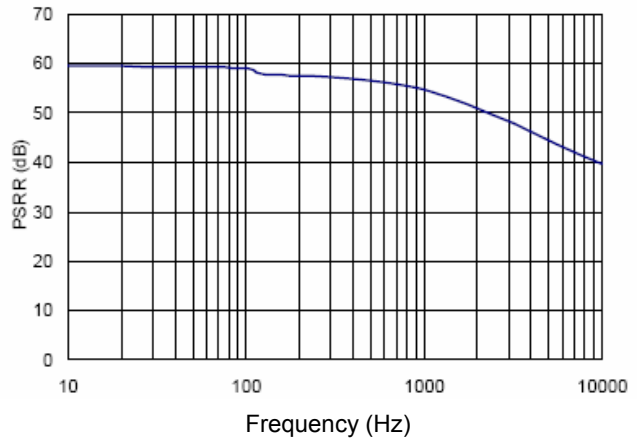

Line Transients

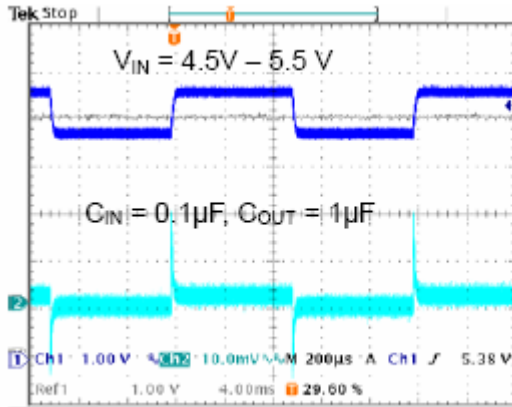

Load Transients

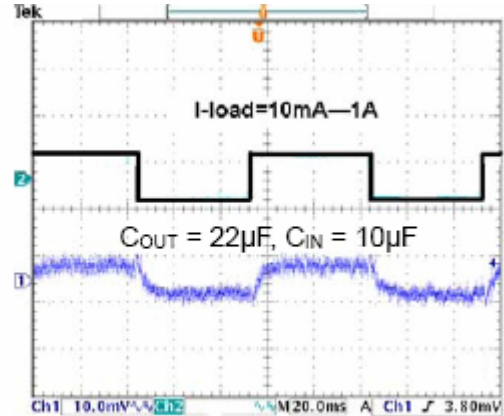

Short Transient Response

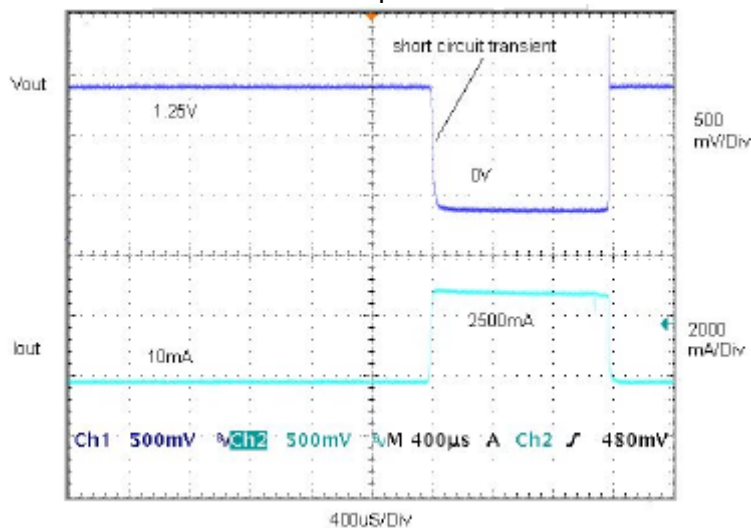

Packing Information

SOT-223

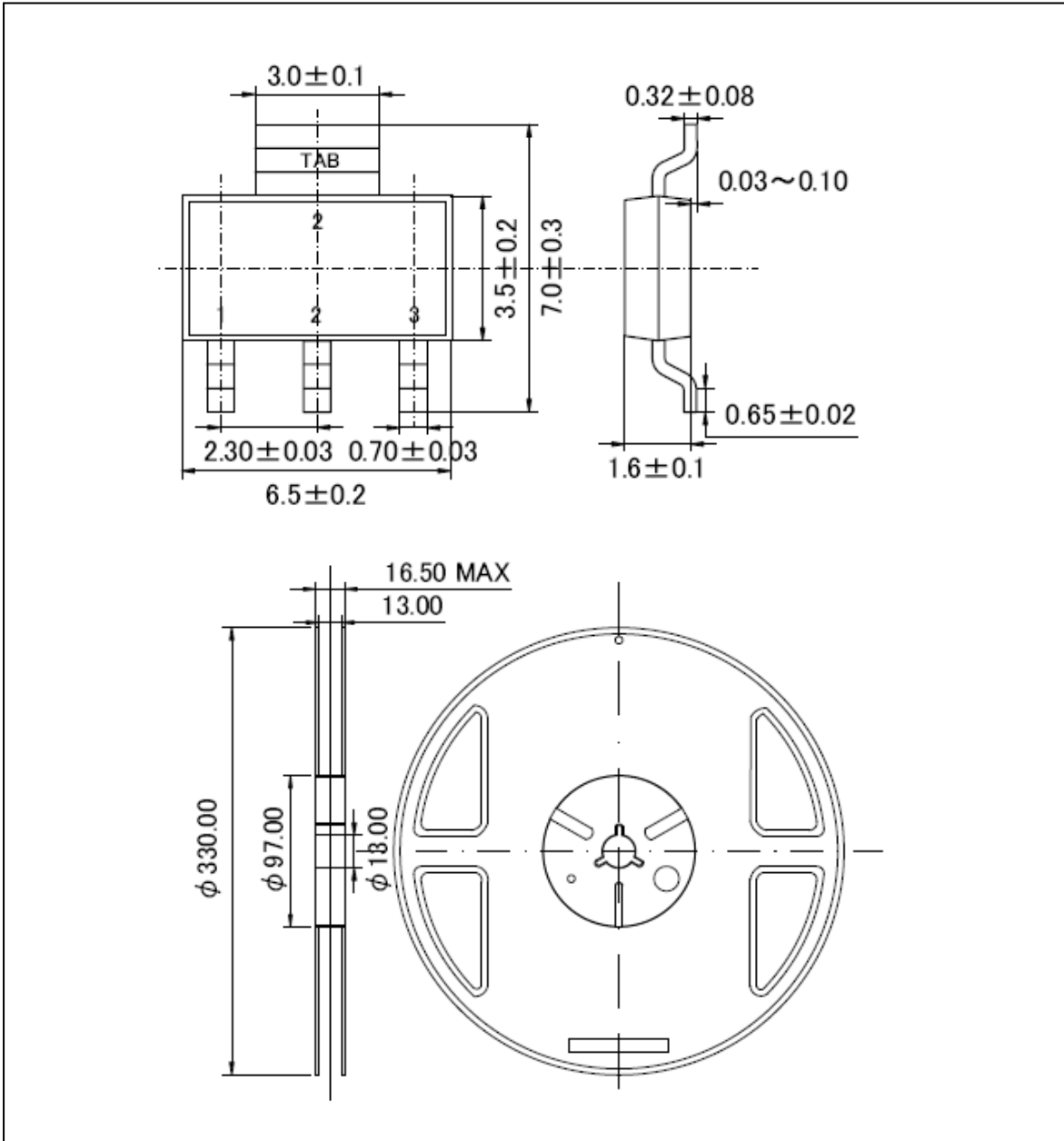

Packing Information

TO-252

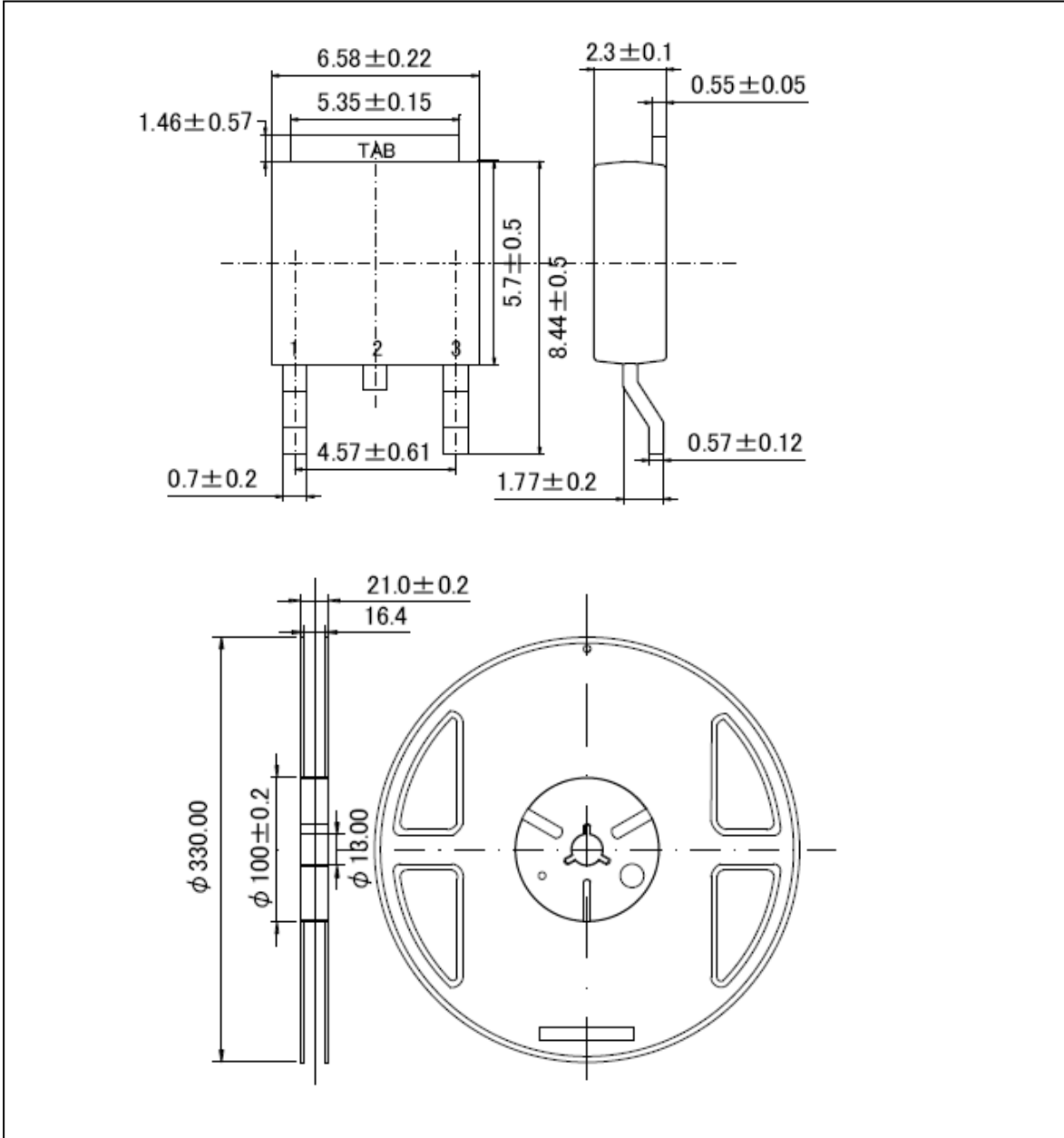

Notes

ACE does not assume any responsibility for use as critical components in life support devices or systems without the express written approval of the president and general counsel of ACE Electronics Co., LTD. As sued herein:

1. Life support devices or systems are devices or systems which, (a) are intended for surgical implant into the body, or (b) support or sustain life, and whose failure to perform when properly used in accordance with instructions for use provided in the labeling, can be reasonably expected to result in a significant injury to the user.
2. A critical component is any component of a life support device or system whose failure to perform can be reasonably expected to cause the failure of the life support device or system, or to affect its safety or effectiveness.