

Description

GM6250 combines high accuracy with very low power consumption, and provides high output current even when the application requires extremely low input-output voltage dropout.

GM6250 includes a precision voltage reference, an error correction circuit, over-temperature protection, and a current limited output driver. Fast transient response to load variations provides excellent stability under dynamic loads.

GM6250 comes in SOT-23 (150mW), and SOT-89 (500mW).

Features

- ◆ Maximum output current up 300mA
- ◆ Output voltage from 1.5V to 5.0V in 0.1V increments
- ◆ Output voltage accuracy : $\pm 2\%$
- ◆ CMOS low power consumption, typically 1.0 μ A at $V_{OUT} = 5.0V$
- ◆ Input stability: typically 0.2%/V
- ◆ Ultra low dropout voltage: 0.38V @ $I_{OUT} = 200mA$ at $V_{OUT} = 5.0V$
- ◆ SOT-23 (150mW), SOT-89 (500mW) and TO-92 packages

Application

Palmtops

Portable Cameras

Video Recorders

Battery Powered Equipment

Reference Voltage Sources

Typical Application Circuits

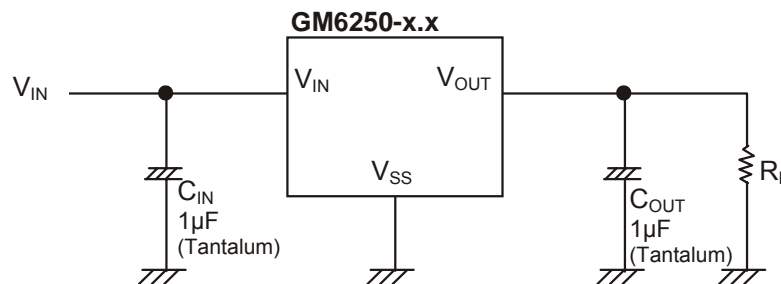

Marking Information and Pin Configurations (Top View)

SOT23

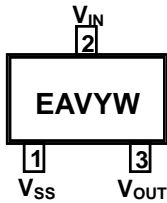

TO92

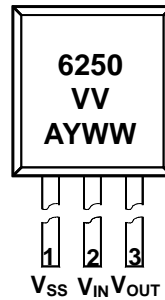

SOT89

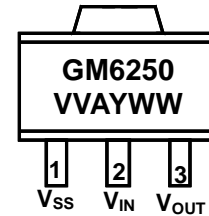

EA: Device Code

V: Voltage Code (see next page)

Y: Year (8 = 2008, 9 = 2009)

W: Week Code

Week 1-26 : A – Z

Week 27-52 : A - Z

Week 53 : A

VV: Voltage suffix (18 = 1.8V, 50 = 5.0V...)

A: Assembly Site Code

Y: Year (8 = 2008, 9 = 2009)

WW: Week Code

Marking Information and Pin Configurations – Green Product (Top View)

SOT23

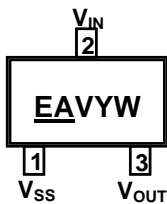

TO92

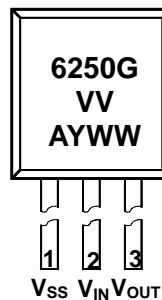

SOT89

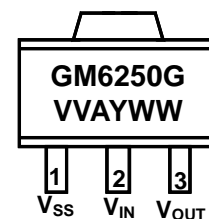

EA: Device Code, Green Product

V: Voltage Code (see next page)

Y: Year (8 = 2008, 9 = 2009)

W: Week Code

Week 1-26 : A – Z

Week 27-52 : A - Z

Week 53 : A

G: Green Product

VV: Voltage suffix (18 = 1.8V, 50 = 5.0V...)

A: Assembly Site Code

Y: Year (8 = 2008, 9 = 2009)

WW: Week Code

Ordering Information

Ordering Number	Output Voltage	Voltage Code	Package	Shipping
GM6250-1.5T92B	1.5V		TO-92	1,000 Units/Bag
GM6250-1.5T92RL			TO-92	2,000 Units/Ammo Pack (Tape)
GM6250-1.5ST23R		C	SOT-23	3,000 Units/Tape and Reel
GM6250-1.5ST89R			SOT-89	1,000 Units/Tape and Reel
GM6250-1.8T92B	1.8V		TO-92	1,000 Units/Bag
GM6250-1.8T92RL			TO-92	2,000 Units/Ammo Pack (Tape)
GM6250-1.8ST23R		E	SOT-23	3,000 Units/Tape and Reel
GM6250-1.8ST89R			SOT-89	1,000 Units/Tape and Reel
GM6250-2.2T92B	2.2V		TO-92	1,000 Units/Bag
GM6250-2.2T92RL			TO-92	2,000 Units/Ammo Pack (Tape)
GM6250-2.2ST23R		D	SOT-23	3,000 Units/Tape and Reel
GM6250-2.2ST89R			SOT-89	1,000 Units/Tape and Reel
GM6250-2.5T92B	2.5V		TO-92	1,000 Units/Bag
GM6250-2.5T92RL			TO-92	2,000 Units/Ammo Pack (Tape)
GM6250-2.5ST23R		G	SOT-23	3,000 Units/Tape and Reel
GM6250-2.5ST89R			SOT-89	1,000 Units/Tape and Reel
GM6250-2.7T92B	2.7V		TO-92	1,000 Units/Bag
GM6250-2.7T92RL			TO-92	2,000 Units/Ammo Pack (Tape)
GM6250-2.7ST23R		T	SOT-23	3,000 Units/Tape and Reel
GM6250-2.7ST89R			SOT-89	1,000 Units/Tape and Reel
GM6250-2.8T92B	2.8V		TO-92	1,000 Units/Bag
GM6250-2.8T92RL			TO-92	2,000 Units/Ammo Pack (Tape)
GM6250-2.8ST23R		H	SOT-23	3,000 Units/Tape and Reel
GM6250-2.8ST89R			SOT-89	1,000 Units/Tape and Reel
GM6250-2.85T92B	2.85V		TO-92	1,000 Units/Bag
GM6250-2.85T92RL			TO-92	2,000 Units/Ammo Pack (Tape)
GM6250-2.85ST23R		I	SOT-23	3,000 Units/Tape and Reel
GM6250-2.85ST89R			SOT-89	1,000 Units/Tape and Reel
GM6250-3.0T92B	3.0V		TO-92	1,000 Units/Bag
GM6250-3.0T92RL			TO-92	2,000 Units/Ammo Pack (Tape)
GM6250-3.0ST23R		J	SOT-23	3,000 Units/Tape and Reel
GM6250-3.0ST89R			SOT-89	1,000 Units/Tape and Reel

Ordering Information (Continued)

Ordering Number	Output Voltage	Voltage Code	Package	Shipping
GM6250-3.2T92B	3.2V		TO-92	1,000 Units/Bag
GM6250-3.2T92RL			TO-92	2,000 Units/Ammo Pack (Tape)
GM6250-3.2ST23R		U	SOT-23	3,000 Units/Tape and Reel
GM6250-3.2ST89R			SOT-89	1,000 Units/Tape and Reel
GM6250-3.3T92B	3.3V		TO-92	1,000 Units/Bag
GM6250-3.3T92RL			TO-92	2,000 Units/Ammo Pack (Tape)
GM6250-3.3ST23R		K	SOT-23	3,000 Units/Tape and Reel
GM6250-3.3ST89R			SOT-89	1,000 Units/Tape and Reel
GM6250-3.5T92B	3.5V		TO-92	1,000 Units/Bag
GM6250-3.5T92RL			TO-92	2,000 Units/Ammo Pack (Tape)
GM6250-3.5ST23R		V	SOT-23	3,000 Units/Tape and Reel
GM6250-3.5ST89R			SOT-89	1,000 Units/Tape and Reel
GM6250-3.6T92B	3.6V		TO-92	1,000 Units/Bag
GM6250-3.6T92RL			TO-92	2,000 Units/Ammo Pack (Tape)
GM6250-3.6ST23R		L	SOT-23	3,000 Units/Tape and Reel
GM6250-3.6ST89R			SOT-89	1,000 Units/Tape and Reel
GM6250-4.0T92B	4.0V		TO-92	1,000 Units/Bag
GM6250-4.0T92RL			TO-92	2,000 Units/Ammo Pack (Tape)
GM6250-4.0ST23R		M	SOT-23	3,000 Units/Tape and Reel
GM6250-4.0ST89R			SOT-89	1,000 Units/Tape and Reel
GM6250-4.4T92B	4.4V		TO-92	1,000 Units/Bag
GM6250-4.4T92RL			TO-92	2,000 Units/Ammo Pack (Tape)
GM6250-4.4ST23R		W	SOT-23	3,000 Units/Tape and Reel
GM6250-4.4ST89R			SOT-89	1,000 Units/Tape and Reel
GM6250-4.5T92B	4.5V		TO-92	1,000 Units/Bag
GM6250-4.5T92RL			TO-92	2,000 Units/Ammo Pack (Tape)
GM6250-4.5ST23R		N	SOT-23	3,000 Units/Tape and Reel
GM6250-4.5ST89R			SOT-89	1,000 Units/Tape and Reel
GM6250-5.0T92B	5.0V		TO-92	1,000 Units/Bag
GM6250-5.0T92RL			TO-92	2,000 Units/Ammo Pack (Tape)
GM6250-5.0ST23R		Q	SOT-23	3,000 Units/Tape and Reel
GM6250-5.0ST89R			SOT-89	1,000 Units/Tape and Reel

Ordering Information – Green Product

Ordering Number	Output Voltage	Voltage Code	Package	Shipping
GM6250-1.5T92BG	1.5V	C	TO-92	1,000 Units/Bag
GM6250-1.5T92RLG			TO-92	2,000 Units/Ammo Pack (Tape)
GM6250-1.5ST23RG			SOT-23	3,000 Units/Tape and Reel
GM6250-1.5ST89RG			SOT-89	1,000 Units/Tape and Reel
GM6250-1.8T92BG	1.8V	E	TO-92	1,000 Units/Bag
GM6250-1.8T92RLG			TO-92	2,000 Units/Ammo Pack (Tape)
GM6250-1.8ST23RG			SOT-23	3,000 Units/Tape and Reel
GM6250-1.8ST89RG			SOT-89	1,000 Units/Tape and Reel
GM6250-2.2T92BG	2.2V	D	TO-92	1,000 Units/Bag
GM6250-2.2T92RLG			TO-92	2,000 Units/Ammo Pack (Tape)
GM6250-2.2ST23RG			SOT-23	3,000 Units/Tape and Reel
GM6250-2.2ST89RG			SOT-89	1,000 Units/Tape and Reel
GM6250-2.5T92BG	2.5V	G	TO-92	1,000 Units/Bag
GM6250-2.5T92RLG			TO-92	2,000 Units/Ammo Pack (Tape)
GM6250-2.5ST23RG			SOT-23	3,000 Units/Tape and Reel
GM6250-2.5ST89RG			SOT-89	1,000 Units/Tape and Reel
GM6250-2.7T92BG	2.7V	T	TO-92	1,000 Units/Bag
GM6250-2.7T92RLG			TO-92	2,000 Units/Ammo Pack (Tape)
GM6250-2.7ST23RG			SOT-23	3,000 Units/Tape and Reel
GM6250-2.7ST89RG			SOT-89	1,000 Units/Tape and Reel
GM6250-2.8T92BG	2.8V	H	TO-92	1,000 Units/Bag
GM6250-2.8T92RLG			TO-92	2,000 Units/Ammo Pack (Tape)
GM6250-2.8ST23RG			SOT-23	3,000 Units/Tape and Reel
GM6250-2.8ST89RG			SOT-89	1,000 Units/Tape and Reel
GM6250-2.85T92BG	2.85V	I	TO-92	1,000 Units/Bag
GM6250-2.85T92RLG			TO-92	2,000 Units/Ammo Pack (Tape)
GM6250-2.85ST23RG			SOT-23	3,000 Units/Tape and Reel
GM6250-2.85ST89RG			SOT-89	1,000 Units/Tape and Reel
GM6250-3.0T92BG	3.0V	J	TO-92	1,000 Units/Bag
GM6250-3.0T92RLG			TO-92	2,000 Units/Ammo Pack (Tape)
GM6250-3.0ST23RG			SOT-23	3,000 Units/Tape and Reel
GM6250-3.0ST89RG			SOT-89	1,000 Units/Tape and Reel

Ordering Information – Green Product (Continued)

Ordering Number	Output Voltage	Voltage Code	Package	Shipping
GM6250-3.2T92BG	3.2V		TO-92	1,000 Units/Bag
GM6250-3.2T92RLG			TO-92	2,000 Units/Ammo Pack (Tape)
GM6250-3.2ST23RG		U	SOT-23	3,000 Units/Tape and Reel
GM6250-3.2ST89RG			SOT-89	1,000 Units/Tape and Reel
GM6250-3.3T92BG	3.3V		TO-92	1,000 Units/Bag
GM6250-3.3T92RLG			TO-92	2,000 Units/Ammo Pack (Tape)
GM6250-3.3ST23RG		K	SOT-23	3,000 Units/Tape and Reel
GM6250-3.3ST89RG			SOT-89	1,000 Units/Tape and Reel
GM6250-3.5T92BG	3.5V		TO-92	1,000 Units/Bag
GM6250-3.5T92RLG			TO-92	2,000 Units/Ammo Pack (Tape)
GM6250-3.5ST23RG		V	SOT-23	3,000 Units/Tape and Reel
GM6250-3.5ST89RG			SOT-89	1,000 Units/Tape and Reel
GM6250-3.6T92BG	3.6V		TO-92	1,000 Units/Bag
GM6250-3.6T92RLG			TO-92	2,000 Units/Ammo Pack (Tape)
GM6250-3.6ST23RG		L	SOT-23	3,000 Units/Tape and Reel
GM6250-3.6ST89RG			SOT-89	1,000 Units/Tape and Reel
GM6250-4.0T92BG	4.0V		TO-92	1,000 Units/Bag
GM6250-4.0T92RLG			TO-92	2,000 Units/Ammo Pack (Tape)
GM6250-4.0ST23RG		M	SOT-23	3,000 Units/Tape and Reel
GM6250-4.0ST89RG			SOT-89	1,000 Units/Tape and Reel
GM6250-4.4T92BG	4.4V		TO-92	1,000 Units/Bag
GM6250-4.4T92RLG			TO-92	2,000 Units/Ammo Pack (Tape)
GM6250-4.4ST23RG		W	SOT-23	3,000 Units/Tape and Reel
GM6250-4.4ST89RG			SOT-89	1,000 Units/Tape and Reel
GM6250-4.5T92BG	4.5V		TO-92	1,000 Units/Bag
GM6250-4.5T92RLG			TO-92	2,000 Units/Ammo Pack (Tape)
GM6250-4.5ST23RG		N	SOT-23	3,000 Units/Tape and Reel
GM6250-4.5ST89RG			SOT-89	1,000 Units/Tape and Reel
GM6250-5.0T92BG	5.0V		TO-92	1,000 Units/Bag
GM6250-5.0T92RLG			TO-92	2,000 Units/Ammo Pack (Tape)
GM6250-5.0ST23RG		Q	SOT-23	3,000 Units/Tape and Reel
GM6250-5.0ST89RG			SOT-89	1,000 Units/Tape and Reel

Absolute Maximum Ratings

PARAMETER	SYMBOL	RATINGS	UNITS
Input Voltage	V_{IN}	12	V
Output Current	I_{OUT}	500	mA
Output Voltage	V_{OUT}	$V_{SS} - 0.3$ to $V_{IN} + 0.3$	V
Continuous Total Power Dissipation	SOT-23	150	mW
	SOT-89	500	
	TO-92	300	
Operating Ambient Temperature	T_A	- 40 to 125	
Storage Temperature	T_{stg}	- 65 to 150	
Lead Temperature (Soldering, 10 sec)		+ 260	

Block Diagram

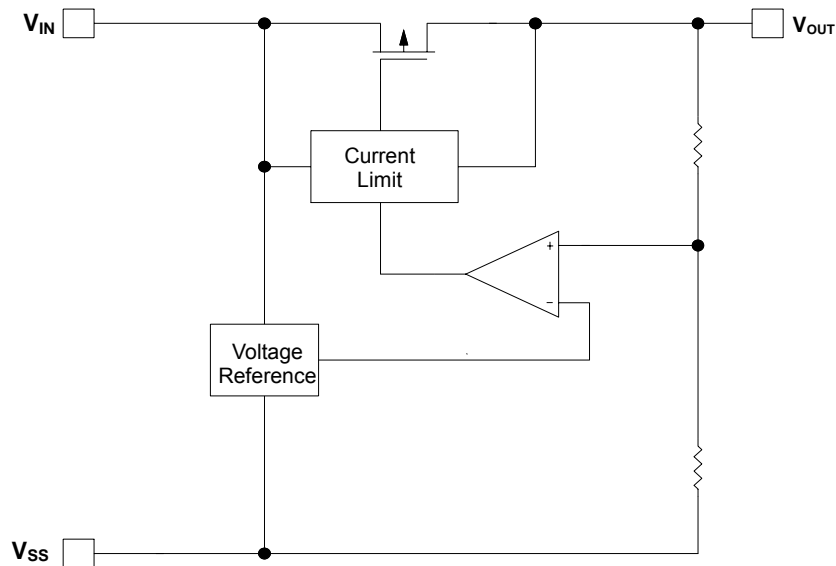

Electrical Characteristics ($T_A = 25^\circ\text{C}$, $V_{IN} = V_{OUT} + 1\text{V}$ unless otherwise noted)

Parameter		Symbol	Condition	Min	Typ	Max	Unit
Output Voltage	GM6250-1.5	V_{OUT}	$I_{OUT} = 40\text{mA}$, $V_{IN} = V_{OUT} + 1\text{V}$	1.470	1.500	1.530	V
	GM6250-2.2			1.764	2.200	2.236	
	GM6250-2.5			2.450	2.500	2.550	
	GM6250-2.7			2.646	2.700	2.754	
	GM6250-2.8			2,744	2.800	2.856	
	GM6250-3.0			2.940	3.000	3.060	
	GM6250-3.2			3.136	3.200	3.264	
	GM6250-3.3			3.234	3.300	3.366	
	GM6250-3.5			3.430	3.500	3.570	
	GM6250-3.6			3.528	3.600	3.672	
	GM6250-4.0			3.920	4.000	4.080	
	GM6250-4.4			4.312	4.400	4.488	
	GM6250-4.5			4.410	4.500	4.590	
	GM6250-5.0			4.900	5.000	5.100	
Line Regulation		ΔV_{OI}	$I_{OUT} = 40\text{mA}$, $V_{OUT} + 1\text{V} < V_{IN} < 10\text{V}$		0.2	0.3	%/V
Load Regulation		ΔV_{OL}	$1\text{mA} < I_{OUT} < 80\text{mA}$		0.02	0.03	%/mA
Dropout Voltage	$V_{OUT} > 2.7\text{V}$	ΔV	$I_{OUT} = 160\text{mA}$		0.4	0.7	V
	$2.0\text{V} < V_{OUT} < 2.7\text{V}$				0.55	0.85	
	$V_{OUT} < 2.0\text{V}$				0.9	1.3	
Current Consumption		I_Q			1.0	2.9	μA
Output Current Limit		I_{CL}		500			mA
Power Supply Rejection Ration		PSRR	10kHz		10		dB

Application Note

Notes on Usage

1. It is recommended to operate the GM6250 series within the stipulated absolute maximum ratings as the IC is liable to malfunction if it is operated outside the ratings.
2. There is a possibility of heat or oscillation as a result of the impedance present between the power supply and the IC's input. Where impedance is greater than 10Ω , it is recommended to use a capacitor (C_{IN}) of at least $1\mu F$ at the input terminal.
3. With a large output current, operations can be stabilized by increasing capacitor size (C_{IN}). If C_{IN} is too small and capacitance of (C_L) is increased, there is a possibility of oscillation due to input impedance. In such case, operation can be stabilized by either increasing the size of C_{IN} or decreasing the size of C_L .
4. Please ensure the output current (I_{OUT}) is less than $P_d \div (V_{IN} - V_{OUT})$ and does not exceed the stipulated continuous for total power dissipation value (P_d) for the package.

CALCULATING POWER DISSIPATION

The GM6250 series precision linear regulators include thermal shutdown and current limit circuitry to protect the devices. However, high power regulators normally operate at high junction temperatures so it is important to calculate the power dissipation and junction temperatures accurately to be sure that you use an adequate heat sink.

The thermal characteristics of an IC depend on four factors:

1. Maximum Ambient Temperature T_A ()
2. Power Dissipation P_D (Watts)
3. Maximum Junction Temperature T_J ()
4. Thermal Resistance Junction to ambient R_{JA} (/W)

These relationships of these four factors is expressed by equation : $T_J = T_A + P_D \times R_{JA}$

Maximum ambient temperature and power dissipation are determined by the design while the maximum junction temperature and thermal resistance depend on the manufacturer and the package type.

Typical Performance Characteristics (for GM6250-3.0)

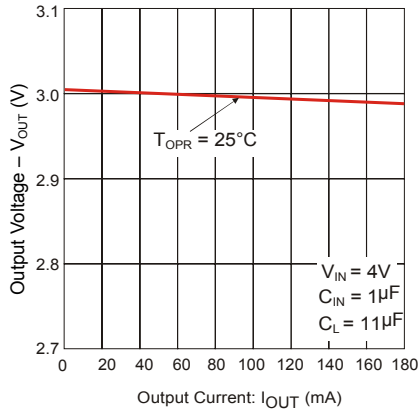

Figure 1: Output Voltage vs. Output Current

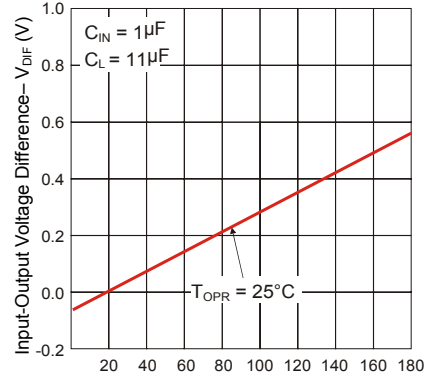

Figure 2: Input/ Output Voltage differential vs. Output Current

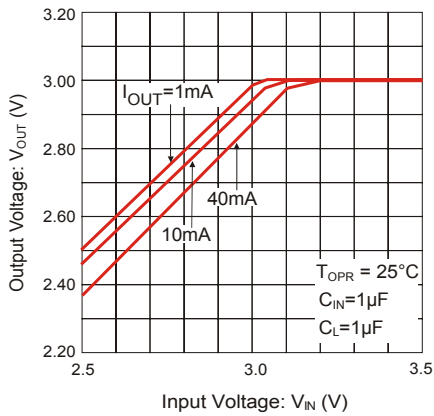

Figure 3: Output Voltage vs. Input voltage

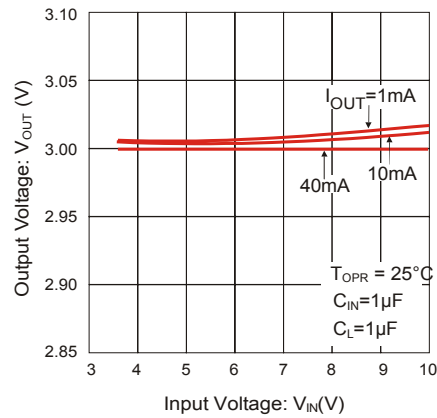

Figure 4: Output Voltage vs. Input voltage

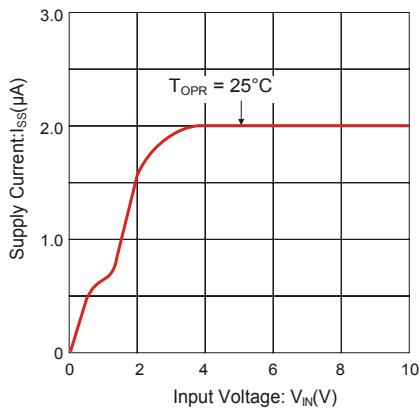

Figure 5: Supply Current vs. Input Voltage

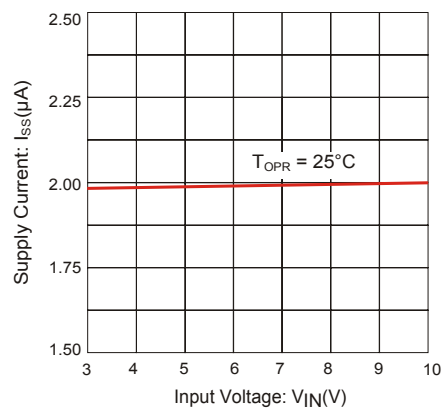

Figure 6: Supply Current vs. Input Voltage

Typical Performance Characteristics (for GM6250-3.0, continued)

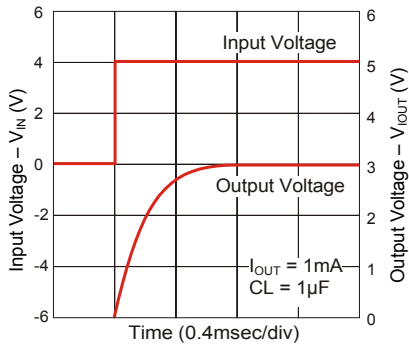

Figure 7: Input Transient Response 1

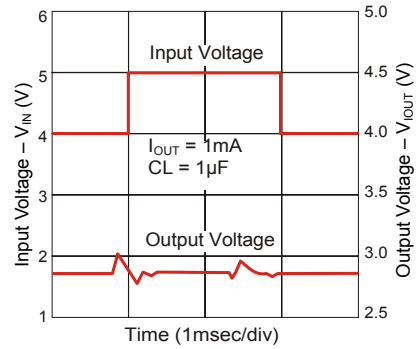

Figure 8: Input Transient Response 2

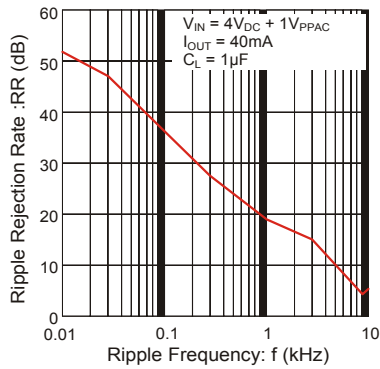
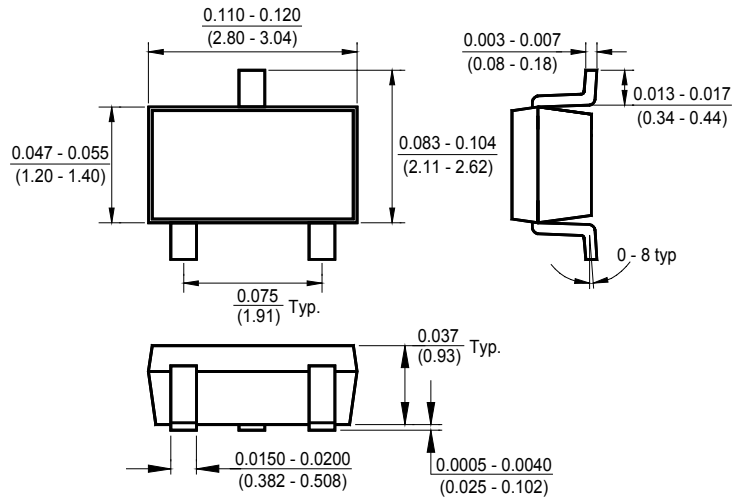
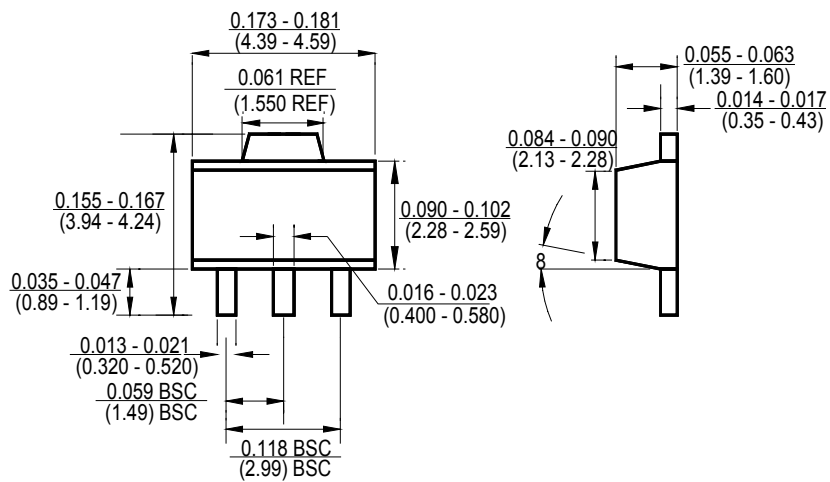

Figure 9: Ripple Rejection Rate

Package Outline Dimensions – SOT 23



Package Outline Dimensions – SOT 89



Package Outline Dimensions – TO 92

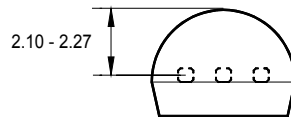
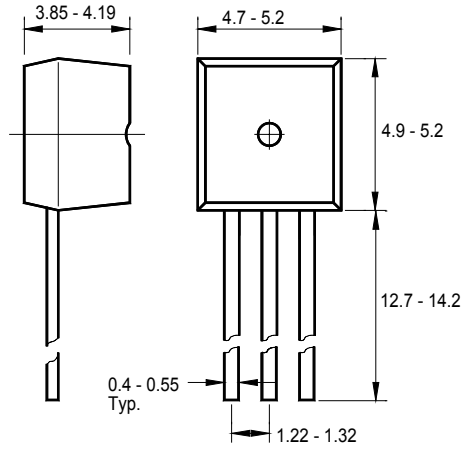

Dimensions are in millimeters

Ordering Number

GM 6250 - 2.2 T92 B G

APM Gamma Micro	Circuit Type	Output Voltage	Package Type	Shipping Type	
		2.2 = 2.2V	T92: TO 92	B: Bag	Blank: Pb-free G: Green
		2.5 = 2.5V	ST89: SOT 89	RL: Ammo Pack (Tape)	
		3.3 = 3.3V	ST23: SOT 23	T: Tube	
		5.0 = 5.0V		R: Tape & Reel	

Note:

Pb-free products:

- ◆ RoHS compliant and compatible with the current requirements of IPC/JEDEC J-STD-020.
- ◆ Suitable for use in SnPb or Pb-free soldering processes with 100% matte tin (Sn) plating.

Green products:

- ◆ Lead-free (RoHS compliant)
- ◆ Halogen free (Br or Cl does not exceed 900ppm by weight in homogeneous material and total of Br and Cl does not exceed 1500ppm by weight)