

319-120 Composite EMI/RFI Backshell with Shield Sock and Self-Locking Rotatable Coupling

A

CONNECTOR DESIGNATOR:	
A	MIL-DTL-5015, -26482 Series II, and -83723 Series I and III
F	MIL-DTL-38999 Series I, II
H	MIL-DTL-38999 Series III and IV
SELF-LOCKING	
ROTATABLE COUPLING	
LOW PROFILE	

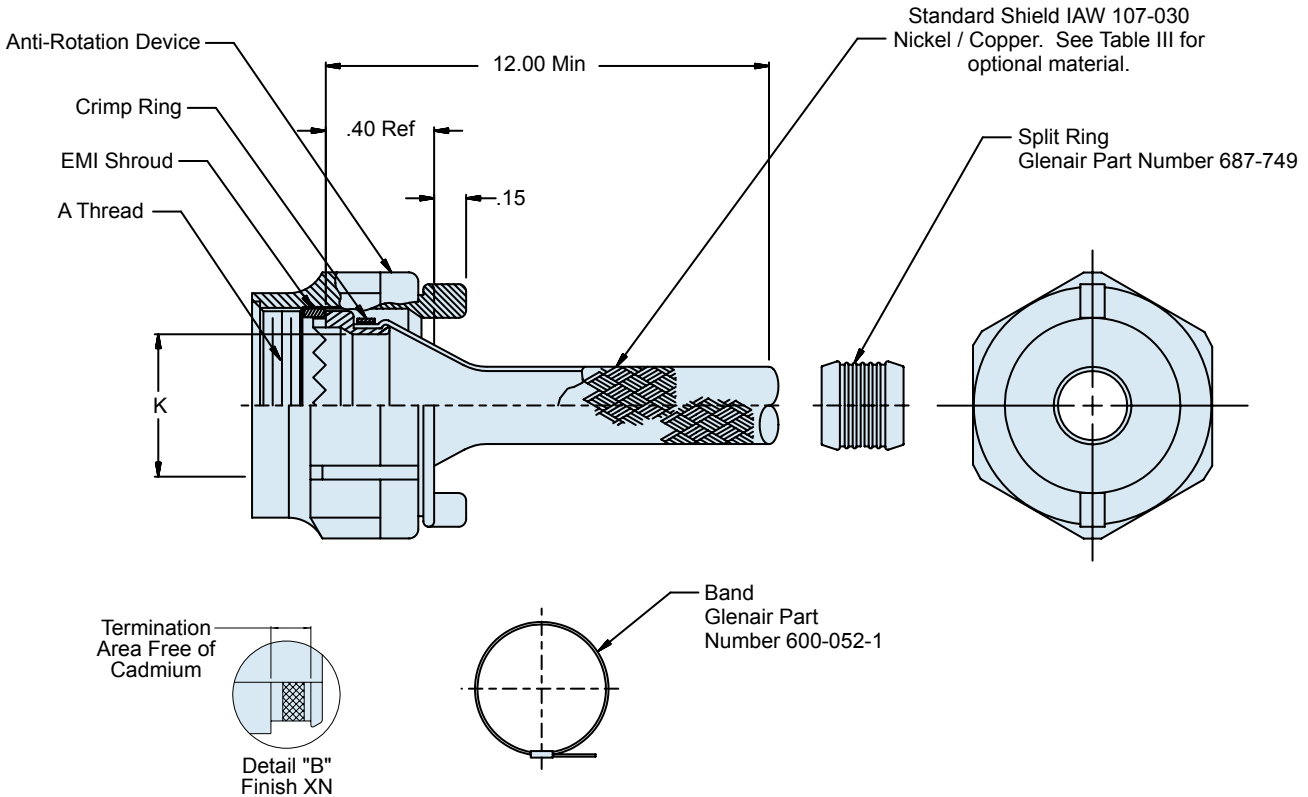
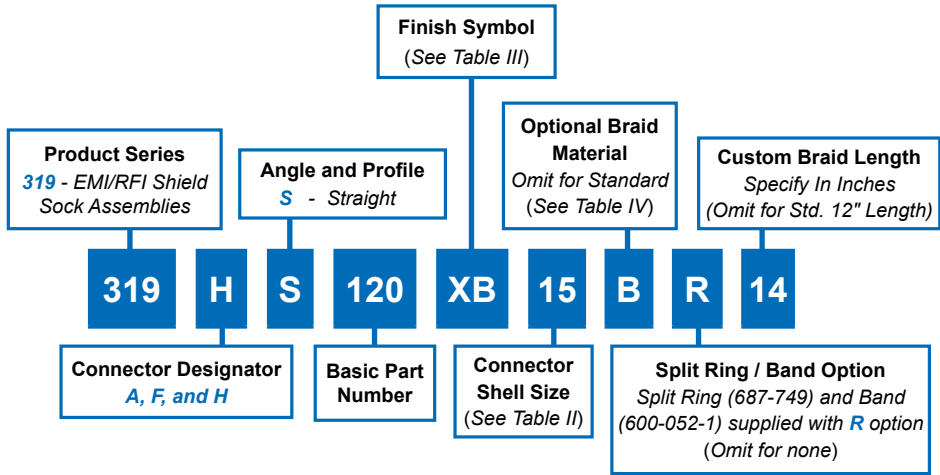

319-120 Composite EMI/RFI Backshell with Shield Sock and Self-Locking Rotatable Coupling



TABLE II: SHELL SIZE				
Shell Size		K Diameter		
A, F	H	A Code	F Code	H Code
08	09	.265 (6.7)	.275 (7.0)	.264 (6.7)
10	11	.370 (9.4)	.412 (10.5)	.390 (9.9)
12	13	.506 (12.9)	.526 (13.4)	.504 (12.8)
14	15	.580 (14.7)	.651 (16.5)	.630 (16.0)
16	17	.705 (17.9)	.776 (19.7)	.756 (19.2)
18	19	.784 (19.9)	.872 (22.1)	.843 (21.4)
20	21	.909 (23.1)	1.007 (25.6)	.969 (24.6)
22	23	1.034 (26.3)	1.132 (28.8)	1.091 (27.7)
24	25	1.149 (29.2)	1.257 (31.9)	1.217 (30.9)

TABLE III: FINISH	
Symbol	Finish
XB	Composite Material—No Plating, Color Black, Brass Interface Shroud and Adapter—Nickel Plated
XMT	2000 Hour Corrosion Resistant Ni-PTFE, Nickel-Fluorocarbon Polymer. <i>1000 Hour Grey™</i>
XN	Composite Material—No Plating, Color Black and Brown, Brass Interface Shroud and Adapter—Selectively Cadmium Plated (See Detail B)

TABLE IV: BRAID TYPE	
Symbol	Braid Type
A	100% AmberStrand®
B	75%/25% AmberStrand® Blend
<i>Standard</i>	Nickel/Copper 34awg
T	Tin/Copper 34awg

NOTES	
1.	See Table I in Intro for front-end dimensional details.
2.	See composite thermoplastic shield sock assembly procedure for detailed installation instructions.
3.	Code F is for series I connectors only. Use mod code -475 for series III connector (connector less shroud)
4.	Coupling nuts supplied unplated.