

14 Pin DIL 5 Tap TTL Compatible Active Delay Lines

EP9810-XX & EP9810-XX-RC

Add "-RC" after part number for RoHS Compliant

PCA Part Number	Tap Delays ($\pm 5\%$ or $\pm 2nS$)				Total Delay ($\pm 5\%$ or $\pm 2nS$)	PCA Part Number	Tap Delays ($\pm 5\%$ or $\pm 2nS$)				Total Delay ($\pm 5\%$ or $\pm 2nS$)
EP9810-25(-RC)	5	10	15	20	25	EP9810-400(-RC)	80	160	240	320	400
EP9810-30(-RC)	6	12	18	24	30	EP9810-420(-RC)	84	168	252	336	420
EP9810-35(-RC)	7	14	21	28	35	EP9810-440(-RC)	88	176	264	352	440
EP9810-40(-RC)	8	16	24	32	40	EP9810-450(-RC)	90	180	270	360	450
EP9810-45(-RC)	9	18	27	36	45	EP9810-470(-RC)	94	188	282	376	470
EP9810-50(-RC)	10	20	30	40	50	EP9810-500(-RC)	100	200	300	400	500
EP9810-60(-RC)	12	24	36	48	60	EP9810-550(-RC)	110	220	330	440	550
EP9810-75(-RC)	15	30	45	60	75	EP9810-600(-RC)	120	240	360	480	600
EP9810-100(-RC)	20	40	60	80	100	EP9810-650(-RC)	130	260	390	520	650
EP9810-125(-RC)	25	50	75	100	125	EP9810-700(-RC)	140	280	420	560	700
EP9810-150(-RC)	30	60	90	120	150	EP9810-750(-RC)	150	300	450	600	750
EP9810-175(-RC)	35	70	105	140	175	EP9810-800(-RC)	160	320	480	640	800
EP9810-200(-RC)	40	80	120	160	200	EP9810-850(-RC)	170	340	510	680	850
EP9810-225(-RC)	45	90	135	180	225	EP9810-900(-RC)	180	360	540	720	900
EP9810-250(-RC)	50	100	150	200	250	EP9810-950(-RC)	190	380	570	760	950
EP9810-300(-RC)	60	120	180	240	300	EP9810-1000(-RC)	200	400	600	800	1000
EP9810-350(-RC)	70	140	210	280	350						

†Whichever is greater. • Delay times referenced from input to leading edges at 25°C, 5.0V, with no load.

DC Electrical Characteristics		Test Conditions	Min.	Max.	Unit
Parameter					
V _{OH}	High-Level Output Voltage	V _{CC} = min. V _{IL} = max. I _{OH} = max	2.7		V
V _{OL}	Low-Level Output Voltage	V _{CC} = min. V _{IH} = min. I _{OL} = max		0.5	V
V _{IK}	Input Clamp Voltage	V _{CC} = min. I _I = I _{IK}		-1.2	V
I _{IH}	High-Level Input Current	V _{CC} = max. V _{IN} = 2.7V		50	µA
		V _{CC} = max. V _{IN} = 5.25V		1.0	mA
I _{IL}	Low-Level Input Current	V _{CC} = max. V _{IN} = 0.5V		-2	mA
I _{OS}	Short Circuit Output Current	V _{CC} = max. V _{OUT} = 0.	-40	-100	mA
		(One output at a time)			
I _{CCH}	High-Level Supply Current	V _{CC} = max. V _{IN} = OPEN		75	mA
I _{CCL}	Low-Level Supply Current	V _{CC} = max. V _{IN} = 0		75	mA
T _{RO}	Output Rise Time	T _d 500 nS (0.75 to 2.4 Volts)		4	nS
		T _d > 500 nS		5	nS
N _H	Fanout High-Level Output	V _{CC} = max. V _{OH} = 2.7V		20 TTL Load	
N _L	Fanout Low-Level Output	V _{CC} = max. V _{OL} = 0.5V		10 TTL Load	

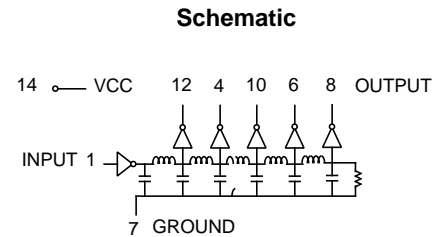

Package

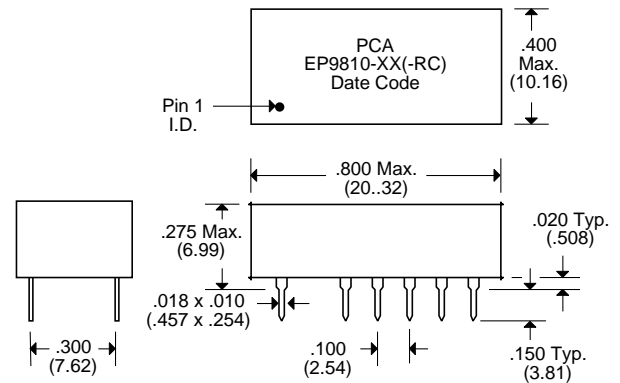

Recommended Operating Conditions		Min.	Max.	Unit
V _{CC}	Supply Voltage	4.75	5.25	V
V _{IH}	High-Level Input Voltage	2.0		V
V _{IL}	Low-Level Input Voltage		0.8	V
I _{IK}	Input Clamp Current		-18	mA
I _{OH}	High-Level Output Current		-1.0	mA
I _{OL}	Low-Level Output Current		20	mA
PW*	Pulse Width of Total Delay	40		%
d*	Duty Cycle		40	%
T _A	Operating Free-Air Temperature	0	+70	°C

*These two values are inter-dependent.

Input Pulse Test Conditions @ 25° C		Unit	
E _{IN}	Pulse Input Voltage	3.2	Volts
PW	Pulse Width % of Total Delay	110	%
T _{RI}	Pulse Rise Time (0.75 - 2.4 Volts)	2.0	nS
PRR	Pulse Repetition Rate @ T _d 200 nS	1.0	MHz
	Pulse Repetition Rate @ T _d > 200 nS	100	KHz
V _{CC}	Supply Voltage	5.0	Volts

Notes :	EP9810-XX	EP9810-XX-RC
1. Assembly Process (Solder Composition)	(Leadframe) SnPb (Assembly Solder) SnPb	Sn SnPb (RoHS exemption 7a)
2. Peak Solder Rating (per JEDEC22-B102D)	225°C	260°C
3. Weight	TBD grams	TBD grams
4. Packaging Information	(Tube) 25 pieces/tube	25 pieces/tube

Unless Otherwise Specified Dimensions are in Inches /mm ± .010 / .25