



### General Specifications

Resistive Element:	Thick film
Substrate:	Aluminum nitride ceramic
Terminals:	Tin/Lead, 90/10 over nickel

### Electrical Specifications

Resistance Value:	50 ohms, $\pm 2\%$
Frequency Range:	DC - 3.0 GHz
Power:	16 Watts
V.S.W.R.:	1.25:1

**Notes:** Tolerance is  $\pm 0.10$ , unless otherwise specified. Operating temperature is  $-55^{\circ}\text{C}$  to  $+125^{\circ}\text{C}$  (see chart). Designed to meet or exceed applicable portions of MIL-E-5400. All dimensions are in inches. **Specifications subject to change without notice.**

### Features

- DC – 3.0 GHz
- 16 Watts
- Aluminum Nitride (AlN) Ceramic
- Surface Mountable
- Non-Nichrome Resistive Element
- Low VSWR
- 100% Tested

### Outline Drawing

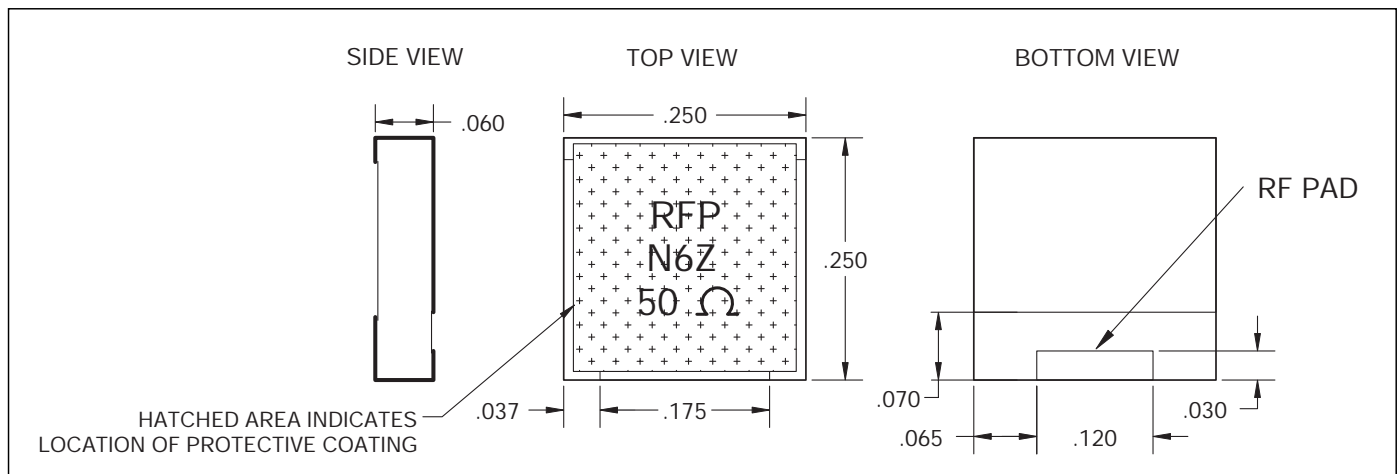

VER. 12/5/01



Available on Tape and Reel for Pick and Place Manufacturing.

Sales Desk USA: Voice: (800) 544-2414 Fax: (315) 432-9121  
Sales Desk Europe: Voice: (+44) 23 92 232392 Fax: (+44) 23 92 251369

# Model RFP-250250N6Z50-2

# Anaren

## RF Power

### Typical Performance

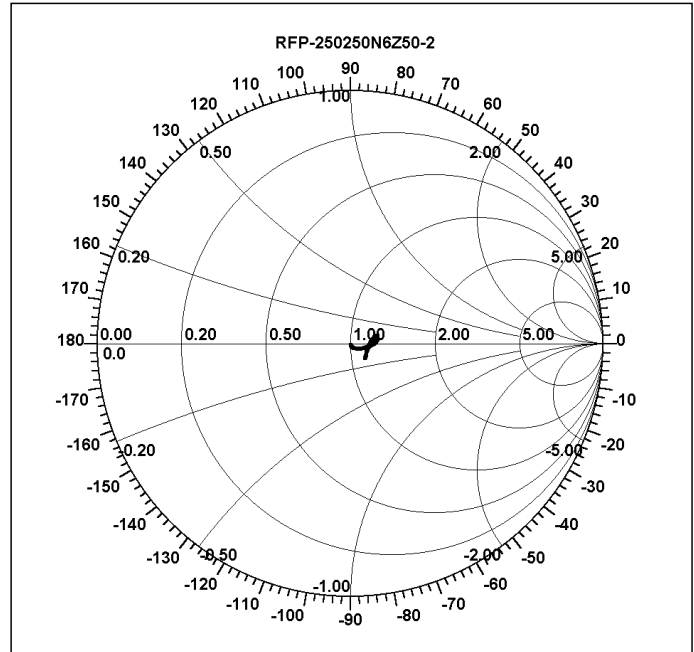
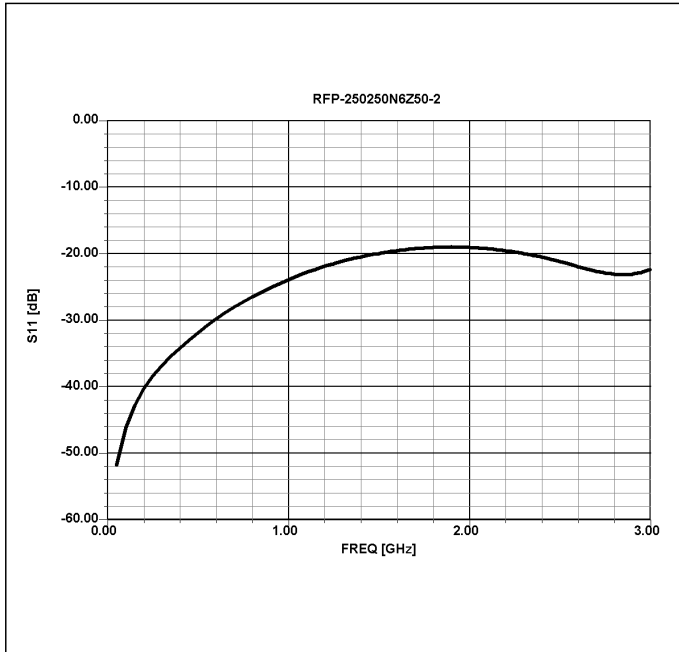

### Power Derating

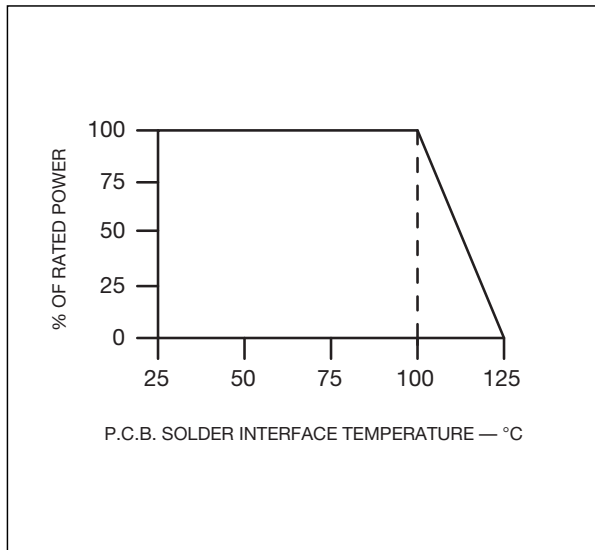

### Suggested Mounting Procedures

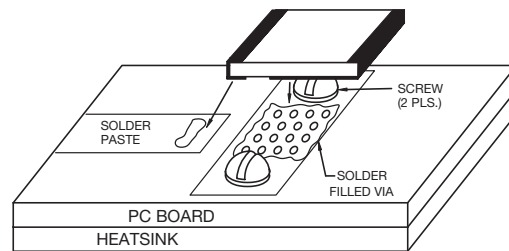

1. Solder part in place using 60/40 type solder with controlled temperature iron (700°F).
2. Drill thermal vias through PCB and fill with solder, such as 60/40 type.
3. To ensure good thermal connectivity to heat sink, drill and tap heatsink and mount PCB board to heat sink using screws.

Available on Tape and Reel for Pick and Place Manufacturing.

