



# 1A Ultra Low-Dropout Linear Regulator

## DESCRIPTION

The EUP7961 is a 1A low-dropout linear regulator that provides a low voltage, high current output with a minimum of external components. It offers high precision, ultra-low dropout, and low ground current.

The EUP7961 operates from an input of 2.5V to 5.5V. This regulator uses small, 1 $\mu$ F ceramic input capacitors and 4.7 $\mu$ F ceramic output capacitors to deliver 1A output current. High bandwidth provides excellent transient response. It is designed to drive digital circuits requiring low voltage at high currents (i.e., PLDs, DSPs, microcontrollers, etc.).

Other features include thermal and current limit protection, a logic-control shutdown mode and an error flag output that goes low when the output voltage drops 10% below nominal value.

It is available in fixed output voltages of 1.5V, 1.8V, 2.5V, 3.3V and as an adjustable device with a 0.8V reference voltage. The adjustable output voltage can be set from 0.8V to 4.5V.

## FEATURES

- 1A Guaranteed Output Current
- 300mV Dropout Voltage at 1A Output
- Stable with Ceramic Capacitors
- $\pm 1.8\%$  Output Voltage Accuracy
- 300 $\mu$ A Low-Ground Pin Current
- 0.1 $\mu$ A Quiescent Current in Shutdown Mode
- Excellent Line and Load Regulation
- Thermal Shutdown and Current Limit Protection
- Error Flag Indication
- Available in SOT223, SOP-8 and SOT-89 Packages
- RoHS Compliant and 100% Lead (Pb)-Free

## APPLICATIONS

- LDO Linear Regulator for Low-Voltage Digital IC
- PC Add-In Cards
- High Efficiency Linear Power Supplies
- Post Regulator

## Typical Application Circuit

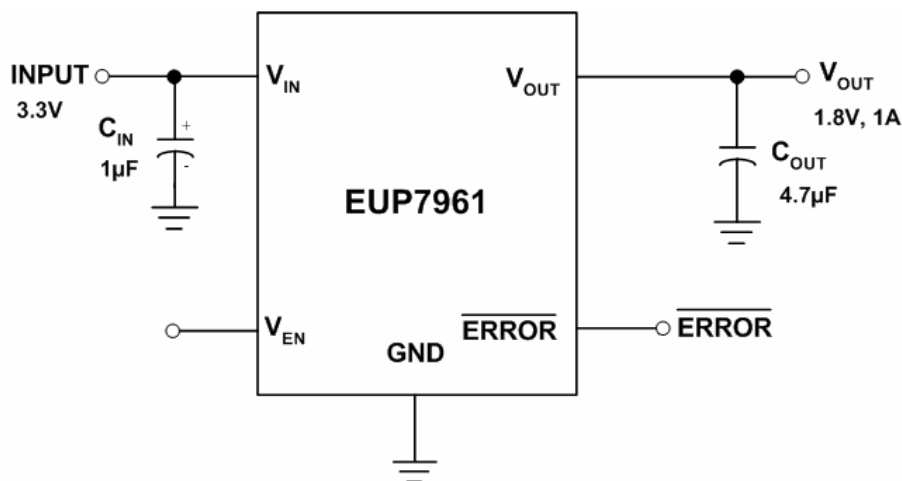

Figure1.

**Block Diagram**

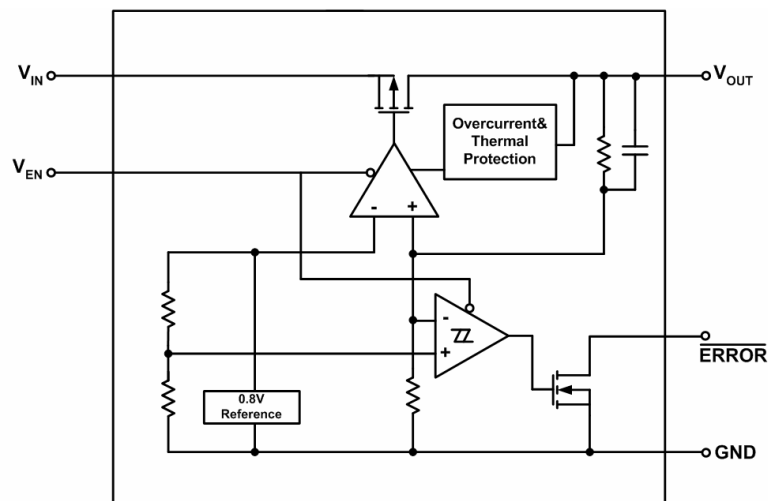

Figure2.

**Pin Configurations**

Package Type	Pin Configurations	Package Type	Pin Configurations
SOT223-3		SOT223-3 (B)	
SOT-89		SOP-8	

**Pin Description**

PIN	SOT-223	SOT-223 (B)	SOT-89	SOP-8	DESCRIPTION
V <sub>EN</sub>	-	-	-	1	Enable Input. Logic high=enable, Logic low=shutdown
V <sub>IN</sub>	1	3	3	2	Input Voltage of the LDO
GND	2	1	2	5,6,7,8	Ground: TAB is connected to ground
V <sub>OUT</sub>	3	2	1	3	Output voltage of the LDO
$\overline{\text{ERROR}}$	-	-	-	4	$\overline{\text{ERROR}}$ Flag Output. Active-low indicated an output fault condition
ADJ	-	-	-	-	Adjustable Regulator Feedback Input. Connect to resistor voltage divider

## Ordering Information

Order Number	Package Type	Marking	Operating Temperature range
EUP7961-15BIR1	SOT223	U xxxx P7961C	-40 °C to 125°C
EUP7961-18BIR1	SOT223	U xxxx P7961D	-40 °C to 125°C
EUP7961-25BIR1	SOT223	U xxxx P7961B	-40 °C to 125°C
EUP7961-33BIR1	SOT223	U xxxx P7961H	-40 °C to 125°C
EUP7961B-15BIR1	SOT223	U xxxx 7961CB	-40 °C to 125°C
EUP7961B-18BIR1	SOT223	U xxxx 7961DB	-40 °C to 125°C
EUP7961B-25BIR1	SOT223	U xxxx 7961BB	-40 °C to 125°C
EUP7961B-33BIR1	SOT223	U xxxx 7961HB	-40 °C to 125°C
EUP7961-15CIR1	SOT-89	U xxxx P7961C	-40 °C to 125°C
EUP7961-18CIR1	SOT-89	U xxxx P7961D	-40 °C to 125°C
EUP7961-25CIR1	SOT-89	U xxxx P7961B	-40 °C to 125°C
EUP7961-33CIR1	SOT-89	U xxxx P7961H	-40 °C to 125°C
EUP7961-15DIR1	SOP-8	U xxxx EUP7961 C	-40 °C to 125°C
EUP7961-18DIR1	SOP-8	U xxxx EUP7961 D	-40 °C to 125°C
EUP7961-25DIR1	SOP-8	U xxxx EUP7961 B	-40 °C to 125°C
EUP7961-33DIR1	SOP-8	U xxxx EUP7961 H	-40 °C to 125°C
EUP7961DIR1	SOP-8	U xxxx EUP7961 A	-40 °C to 125°C

EUP7961-

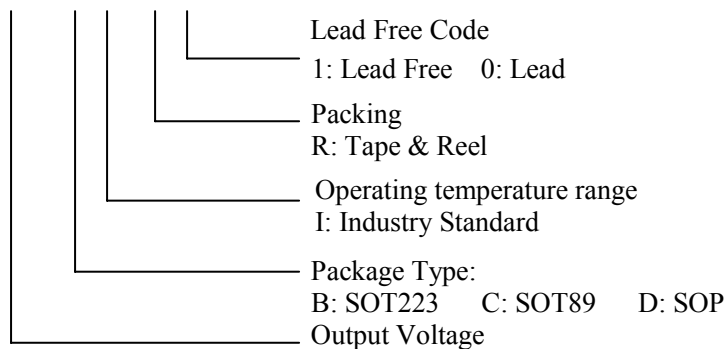

## Absolute Maximum Ratings

- Supply Voltage  $V_{IN}$  ----- 5.5V
- Package Thermal Resistance
  - SOT-223,  $\theta_{JA}$  ----- 115°C/W
  - SOP-8,  $\theta_{JA}$  ----- 125°C/W
- Power Dissipation, PD@TA=25°C
  - SOT-223 ----- 0.87W
  - SOP-8 ----- 0.8W
- Junction Temperature ----- 150°C
- Storage Temperature ----- -65°C to +150°C
- Lead Temp ----- 260°C
- ESD Rating
  - Human Body Model ----- 2kV

## Operating Ratings

- Supply Voltage  $V_{IN}$  ----- 2.5 to 5.5V
- Enable Input Voltage ----- 0V to 5.5V
- Junction Temperature ----- -40°C to +125°C

## Electrical Characteristics

Limits in standard typeface are for  $T_J=25^\circ\text{C}$ . Unless otherwise specified:  $V_{IN}=V_{OUT(nom)}+1\text{V}$ ,  $I_L=10\text{mA}$ ,  $C_{OUT}=4.7\mu\text{F}$

Symbol	Parameter	Conditions	EUP7961			Unit
			Min	Typ	Max.	
$V_{OUT}$	Output Voltage Tolerance	$V_{OUT}+1\text{V} \leq V_{IN} \leq 5.5\text{V}$ $10\text{mA} \leq I_L \leq 1\text{A}$	-1.8		1.8	%
	Line Regulation	$V_{OUT}+1\text{V} \leq V_{IN} \leq 5.5\text{V}$		0.1	0.24	%
	Load Regulation	$10\text{mA} \leq I_L \leq 1\text{A}$		0.08	0.32	%
$V_{IN}-V_{OUT}$	Dropout Voltage	$I_L = 100\text{mA}$		35	50	mV
		$I_L = 1\text{A}$		300	500	
$I_{GND}$	Ground Pin Current in Normal Operation Mode	$I_L = 10\text{mA}$		300		$\mu\text{A}$
		$I_L = 1\text{A}$		500		
	Ground Pin Current in Shutdown Mode	$V_{EN} \leq 0.3\text{V}$	0.01		10	$\mu\text{A}$
$I_{O(PK)}$	Peak Output Current	$V_O \geq V_{O(NOM)} - 4\%$		1.5		A
<b>Short Circuit Protection</b>						
$I_{SC}$	Short Circuit Current			1.7		A

## Electrical Characteristics

Limits in standard typeface are for  $T_J=25^{\circ}\text{C}$ . Unless otherwise specified:  $V_{IN}=V_{OUT(nom)}+1\text{V}$ ,  $I_L=10\text{mA}$ ,  $C_{OUT}=4.7\mu\text{F}$

Symbol	Parameter	Conditions	EUP7961			Unit
			Min	Typ	Max.	
$V_{IH}$	Enable Threshold	Output = High	<b>1.4</b>	$V_{IN}$	<b>0.3</b>	V
$V_{IL}$		Output = Low		0		
$T_{dOFF}$	Turn-off delay	$I_L = 1\text{A}$		20		$\mu\text{s}$
$T_{dON}$	Turn-on delay	$I_L = 1\text{A}$		20		
$I_{EN}$	$V_{EN}$ Pin Input Current	$V_{EN}=V_{IN}$		0.1	1	$\mu\text{A}$
<b>ERROR Flag</b>						
$V_T$	Threshold			10		%
$V_{TH}$	Threshold Hysteresis			5		%
$V_{EF(Sat)}$	ERROR Flag Saturation	$I_{SINK}=100\mu\text{A}$		0.02	<b>0.1</b>	V
$T_d$	Flag Reset Delay			1		$\mu\text{s}$
$I_{IK}$	ERROR Flag Pin Leakage Current			1		nA
$I_{max}$	ERROR Flag Pin Sink Current	$V_{Error}=0.5\text{V}$		3.8		mA
<b>AC Parameters</b>						
PSRR	Ripple Rejection	$V_{IN}=V_{OUT}+1\text{V}$ $C_{OUT}=10\mu\text{F}$ $V_{OUT}=3.3\text{V}$ , $f=120\text{Hz}$		60		dB
$e_n$	Output Noise Voltage	$\text{BW}=10\text{Hz}-100\text{kHz}$ $V_{OUT}=2.5\text{V}$		150		$\mu\text{V(rms)}$
<b>Over Temperature Protection</b>						
$T_{SH(t)}$	Shutdown Threshold			150		$^{\circ}\text{C}$
$T_{SH(h)}$	Thermal Shutdown Hysteresis			10		$^{\circ}\text{C}$

Typical Operating Characteristics

Drop-Out Voltage Vs Temperature for Different Load Current

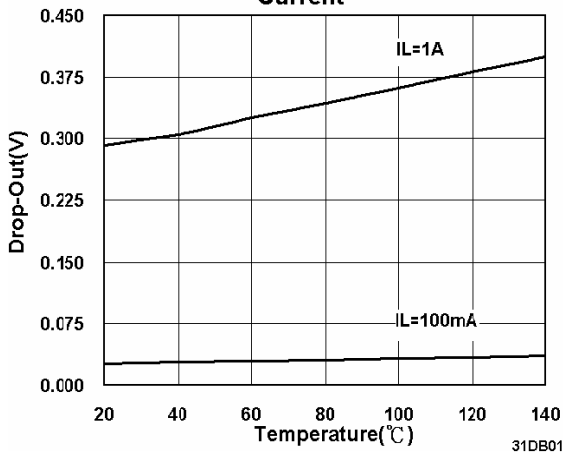

Load Transient Response

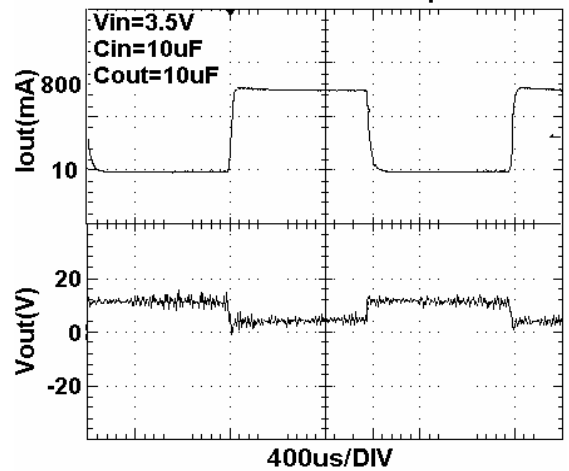

Ground Pin Current Vs Input Voltage (VSD=VIN)

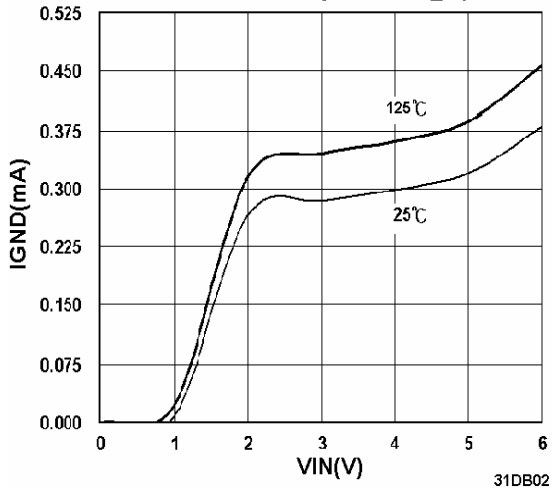

Input Voltage Vs Output Voltage

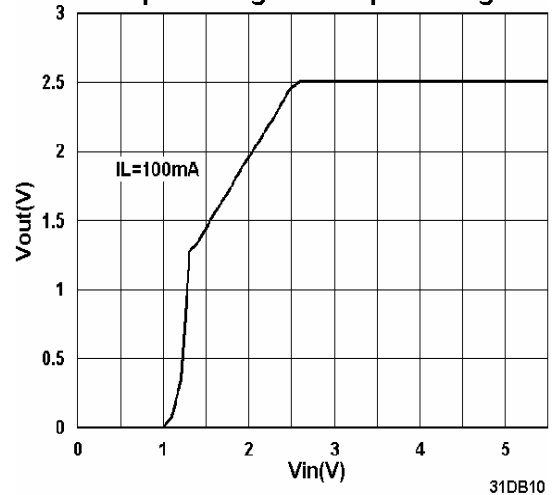

Ground Current Vs Temperature (VSD=VIN)

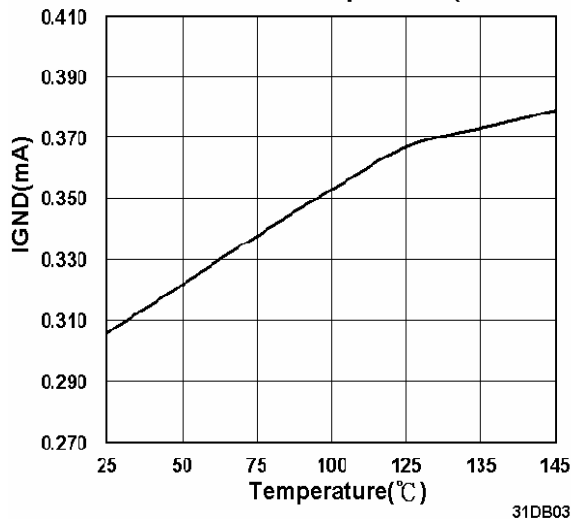

PSRR Output

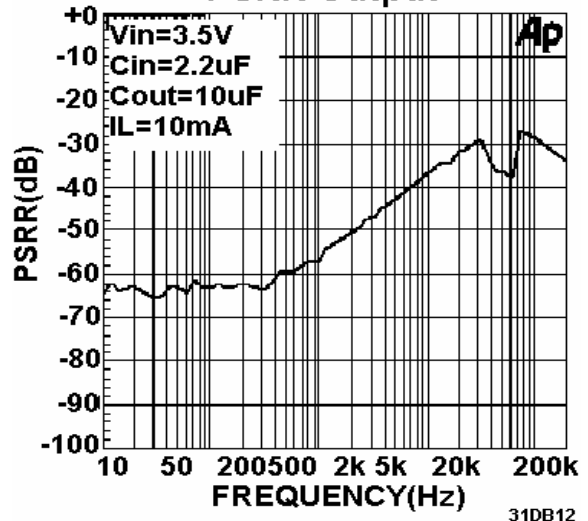

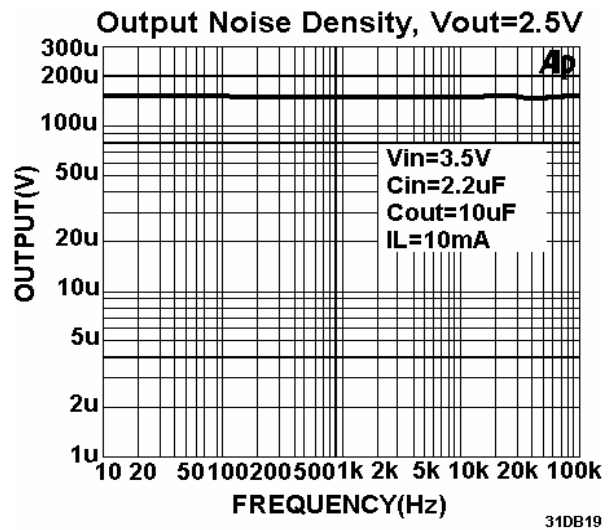
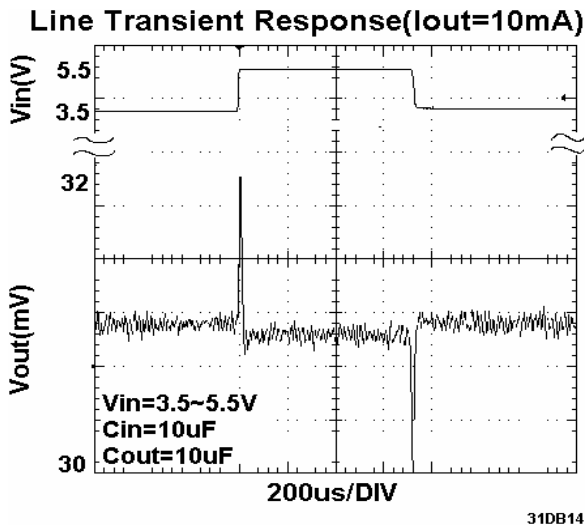
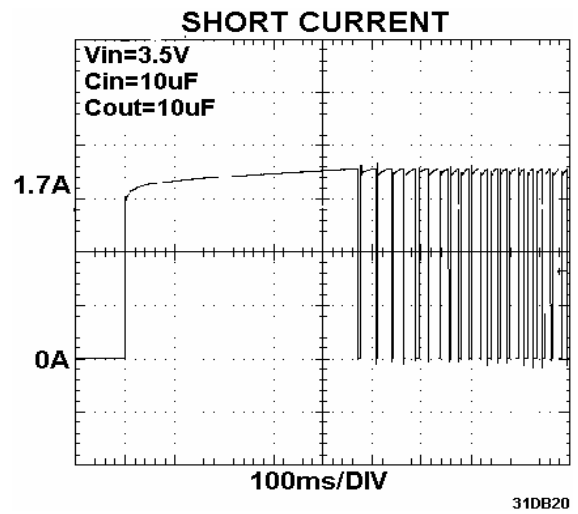
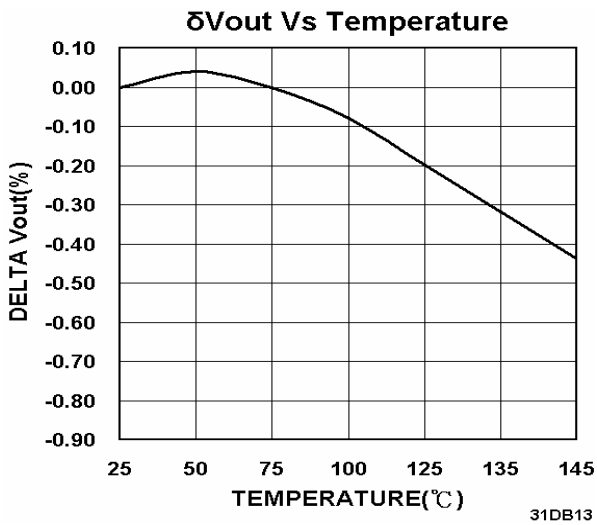

## Application Note

### External Capacitors

Like any low-dropout regulator, the EUP7961 requires external capacitors for regulator stability. These capacitors must be correctly selected for good performance.

### Input Capacitor

An input capacitance of 1μF is required between the EUP7961 input pin and ground (the amount of the capacitance may be increased without limit).

This capacitor must be located a distance of not more than 1cm from the input pin and returned to a clean analog ground. Any good quality ceramic, tantalum, or film capacitor may be used at the input.

If a tantalum capacitor is used at the input, it must be guaranteed by the manufacturer to have a surge current rating sufficient for the application.

There are no requirements for the ESR on the input capacitor, but tolerance and temperature coefficient must be considered when selecting the capacitor to ensure the capacitance will be 1μF over the entire operating temperature range.

### Output Capacitor

The EUP7961 is designed specifically to work with very small ceramic output capacitors. A ceramic capacitor (temperature characteristics X7R, X5R, Z5U, or Y5V) in 4.7 to 22μF range with 5mΩ to 200mΩ ESR range is suitable in the EUP7961 application circuit.

The output capacitor must meet the requirement for minimum amount of capacitance and also have an ESR (Equivalent Series Resistance) value which is within a stable range (5mΩ to 200mΩ)

### No-Load Stability

The EUP7961 will remain stable and in regulation with no external load. This is specially important in CMOS RAM keep-alive applications.

### On/Off Input Operation

The EUP7961 is turned off by pulling the V<sub>EN</sub> pin low, and turned on by pulling it high. If this feature is not used, the V<sub>EN</sub> pin should be tied to V<sub>IN</sub> to keep the regulator output on at all time. To assure proper operation, the signal source used to drive the V<sub>EN</sub> input must be able to swing above and below the specified turn-on/off voltage thresholds listed in the Electrical Characteristics section under V<sub>IL</sub> and V<sub>IH</sub>.

### ERROR Flag Operation

The EUP7961 produces a logic low signal at the ERROR Flag pin when the output drops out of regulation due to low input voltage, current limiting, or thermal limiting. This flag has a built in hysteresis.

The internal ERROR flag comparator has an open drain output stage. Hence, the ERROR pin should be pulled high through a pull up resistor. The ERROR pin must be connected to ground if this function is not used. It should also be noted that when the shutdown pin is pulled low, the ERROR pin is forced to be invalid for reasons of saving power in shutdown mode.

### Adjustable Operation

The adjustable version of the EUP7961 has an output voltage range of 0.8V to 4.5V. The output voltage of the EUP7961 adjustable regulator is programmed using an external resistor divider as shown in Figure3. The output voltage is calculated using:

$$V_O = V_{ref} \times \left(1 + \frac{R_1}{R_2}\right)$$

Where:

V<sub>ref</sub>= 0.8V typ. (the internal reference voltage)

Utilize the following equation for adjusting the output to a particular voltage:

$$P_I = R_2 \left[ \frac{V_O}{0.8V} - 1 \right]$$

Choose R<sub>2</sub>=50k to optimize accuracy, power supply rejection, noise and power consumption.

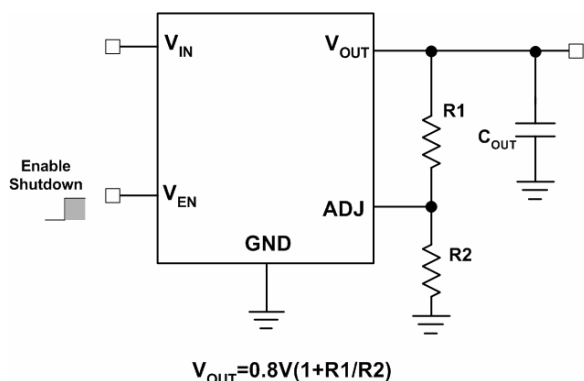

**Figure3. Adjustable Regulator with Resistors**



### Power Dissipation

EUP7961 can deliver a continuous current of 2A over the full operating temperature range. A heatsink may be required depending on the maximum power dissipation and maximum ambient temperature of the application. Under all possible conditions, the junction temperature must be within the range specified under operating conditions. The total power dissipation of the device is given by:

$$P_D = (V_{IN} - V_{OUT})I_{OUT} + (V_{IN})I_{GND}$$

Where  $I_{GND}$  is the operating ground current of the device (specified under Electrical Characteristics).

The maximum allowable temperature rise ( $T_{Rmax}$ ) depends on the maximum ambient temperature ( $T_{Amax}$ ) of the application, and the maximum allowable junction temperature ( $T_{Jmax}$ ):

$$T_{Rmax} = T_{Jmax} - T_{Amax}$$

The maximum allowable value for junction to ambient Thermal Resistance,  $\theta_{JA}$ , can be calculated using the formula:

$$\theta_{JA} = T_{Rmax} / P_D$$

### PCB Layout

Good PC layout practices must be used or instability can be induced because of ground loops and voltages drops. The input and output capacitors must be directly connected to the input, output, and ground pins of the regulator using traces which do not have other currents flowing in them.

The best way to do this is to lay out  $C_{IN}$  and  $C_{OUT}$  near the device with short traces to the  $V_{IN}$ ,  $V_{OUT}$ , and ground pins. The regulator ground pin should be connected to the external circuit ground so that the regulator and its capacitors have a “single point ground”.

It should be noted that stability problems have been seen in applications where “vias” to an internal ground plane were used at the ground points of the IC and the input and output capacitors. This was caused by varying ground potentials at these nodes resulting from current flowing through the ground plane. Using a single point ground technique for the regulator and its capacitors fixed the problem.

Since high current flows through the traces going into  $V_{IN}$  and coming from  $V_{OUT}$ , Kelvin connect the capacitor leads to these pins so there is no voltage drop in series with the input and output capacitors.

## Packaging Information

## SOT223-3

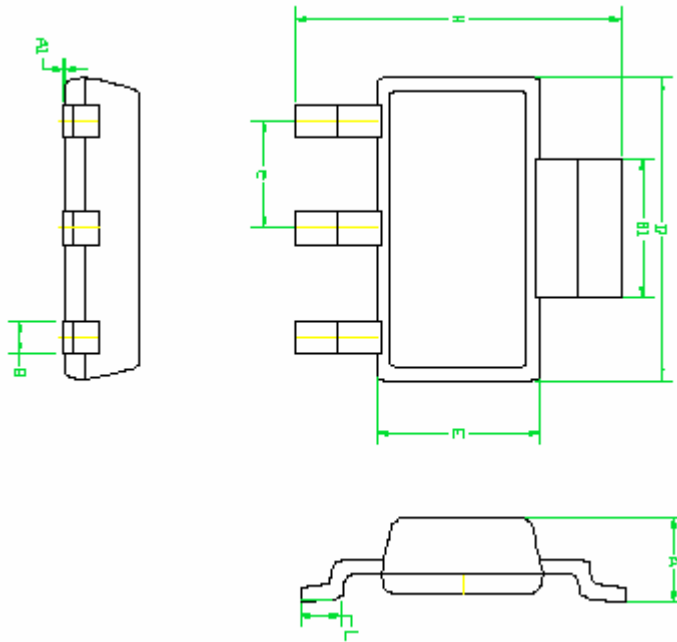

SYMBOLS	MILLIMETERS		INCHES	
	MIN.	MAX.	MIN.	MAX.
A	1.50	1.80	0.059	0.071
A1	0.00	0.10	0.000	0.004
B	0.60	0.80	0.024	0.031
B1	2.90	3.10	0.114	0.122
D	6.50		0.256	
E	3.50		0.138	
e	2.30		0.090	
H	6.70	7.30	0.264	0.287
L	0.80	1.10	0.031	0.043

SOP-8

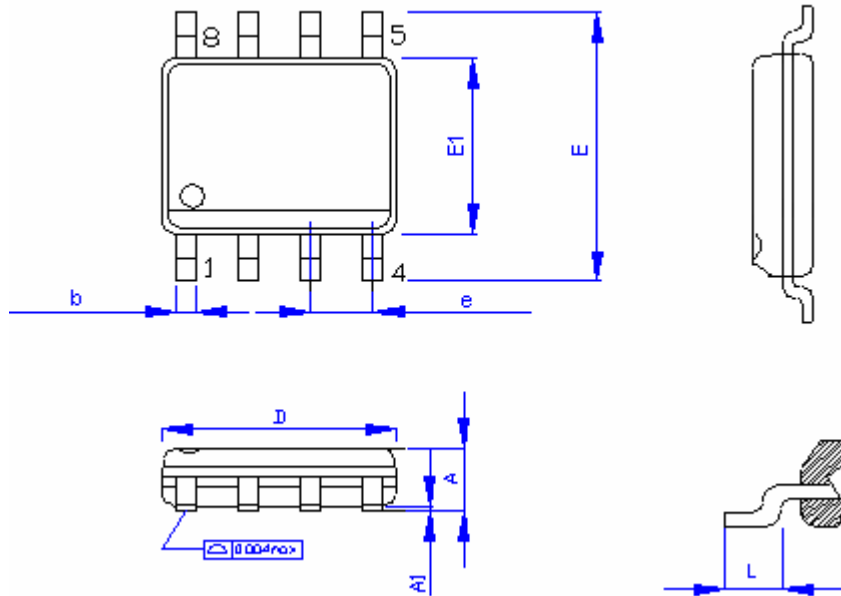

SYMBOLS	MILLIMETERS		INCHES	
	MIN.	MAX.	MIN.	MAX.
A	1.35	1.75	0.053	0.069
A1	0.05	0.25	0.002	0.010
D	4.90		0.193	
E1	3.90		0.153	
E	5.80	6.20	0.228	0.244
L	0.40	1.27	0.016	0.050
b	0.33	0.51	0.013	0.020
e	1.27		0.500	

## SOT-89

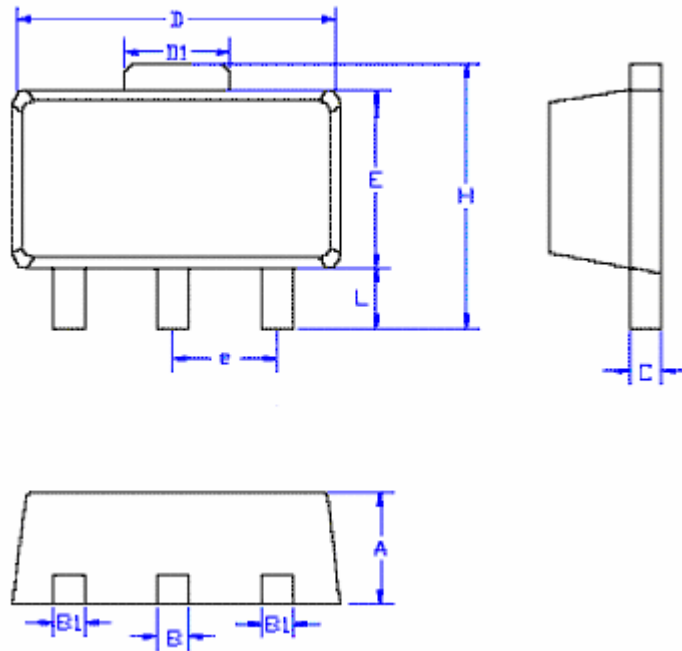

SYMBOLS	MILLIMETERS		INCHES	
	MIN.	MAX.	MIN.	MAX.
A	1.40	1.60	0.055	0.063
L	0.89	1.20	0.035	0.047
B1	0.36	0.48	0.014	0.019
B	0.44	0.56	0.017	0.022
C	0.35	0.44	0.014	0.017
D	4.40	4.60	0.173	0.181
D1	1.35	1.83	0.053	0.072
H	3.94	4.25	0.155	0.167
E	2.29	2.60	0.090	0.102
e	1.50		0.059	