

Single Synchronous Buck PWM DC-DC Controller

General Description

The RT9202 is a single power supply PWM DC-DC converter controller designed to drive N-MOSFET in a synchronous buck topology. The IC integrates the control, output adjustment, monitoring and protection functions in a small 8-pin package.

The RT9202 uses a low gain voltage mode PWM control for simple application design. An internal 0.8V reference allows the output voltage to be precisely regulated to low voltage requirement. A fixed 300kHz oscillator reduces the component size for saving board space.

The RT9202 features over current protection, over voltage protection, and under voltage lock-out. The output current is monitored by sensing the voltage drop across the MOSFET's $R_{DS(ON)}$, which eliminates the need for a current sensing resistor.

Ordering Information

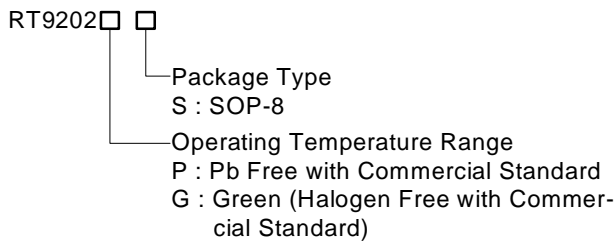

Note :

RichTek Pb-free and Green products are :

- }RoHS compliant and compatible with the current requirements of IPC/JEDEC J-STD-020.
- }Suitable for use in SnPb or Pb-free soldering processes.
- }100%matte tin (Sn) plating.

Features

- | Operate From 5V
- | 0.8V Internal Reference
- | Drive Two N-MOSFETs
- | Voltage Mode PWM Control
- | Fast Transient Response
- | Fixed 300kHz Oscillator Frequency
- | Full 0 to 100% Duty Cycle
- | Internal Soft Start
- | Adaptive Non-Overlapping Gate Driver
- | Over-Current Monitor Uses MOSFET $R_{DS(ON)}$
- | Over-Voltage Protection Uses Low-Side MOSFET
- | RoHS Compliant and 100% Lead (Pb)-Free

Applications

- | Motherboard Power Regulation for Computers
- | Subsystems Power Supplies
- | Cable Modems, Set Top Box, and DSL Modems
- | DSP and Core Communications processor Supplies
- | Memory Power Supplies
- | Personal Computer Peripherals
- | Industrial Power Supplies
- | 5V-Input DC-DC Regulators
- | Low Voltage Distributed Power Supplies

Pin Configurations

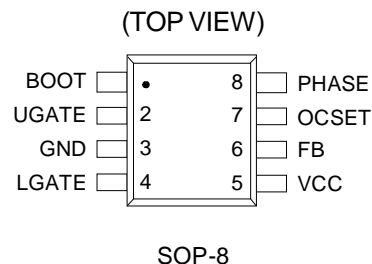

Typical Application Circuit

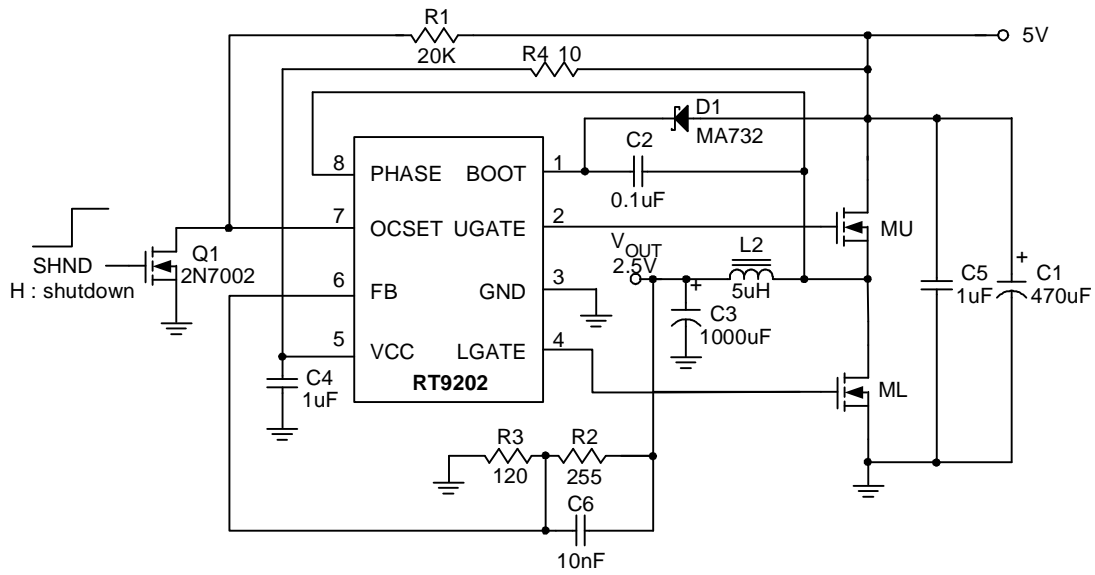

Figure 1. RT9202 powered from 5V only

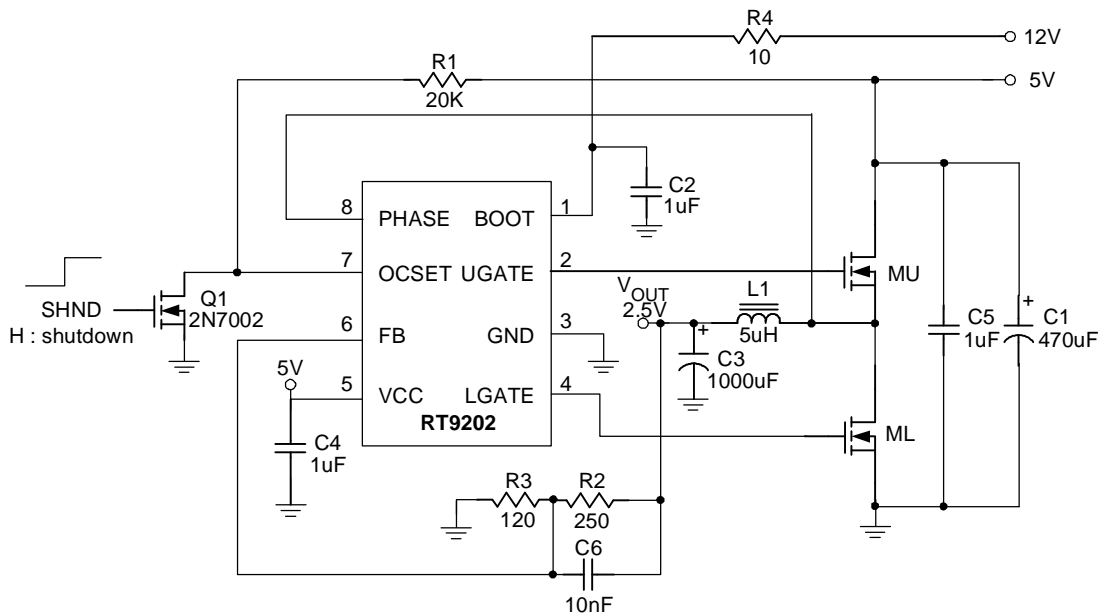
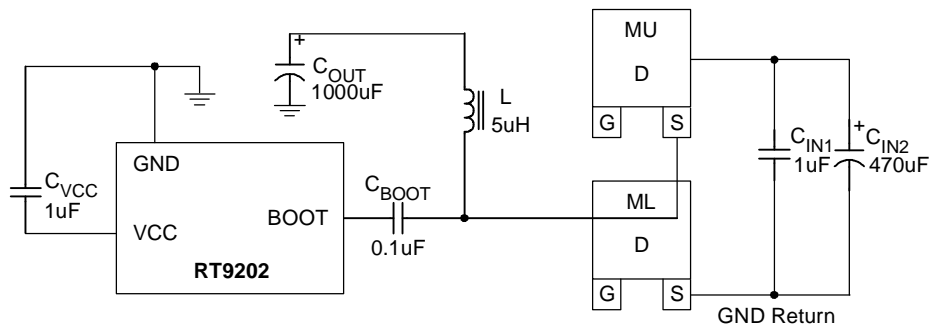

Figure 2. RT9202 powered from 12V and 5V



Layout Placement

Layout Notes

1. Put C_{IN1} & C_{IN2} to be near the MU drain and ML source nodes.
2. Put RT9202 to be near the C_{OUT}
3. Put C_{BOOT} as close as to BOOT pin
4. Put C_{VCC} as close as to VCC pin

Function Block Diagram

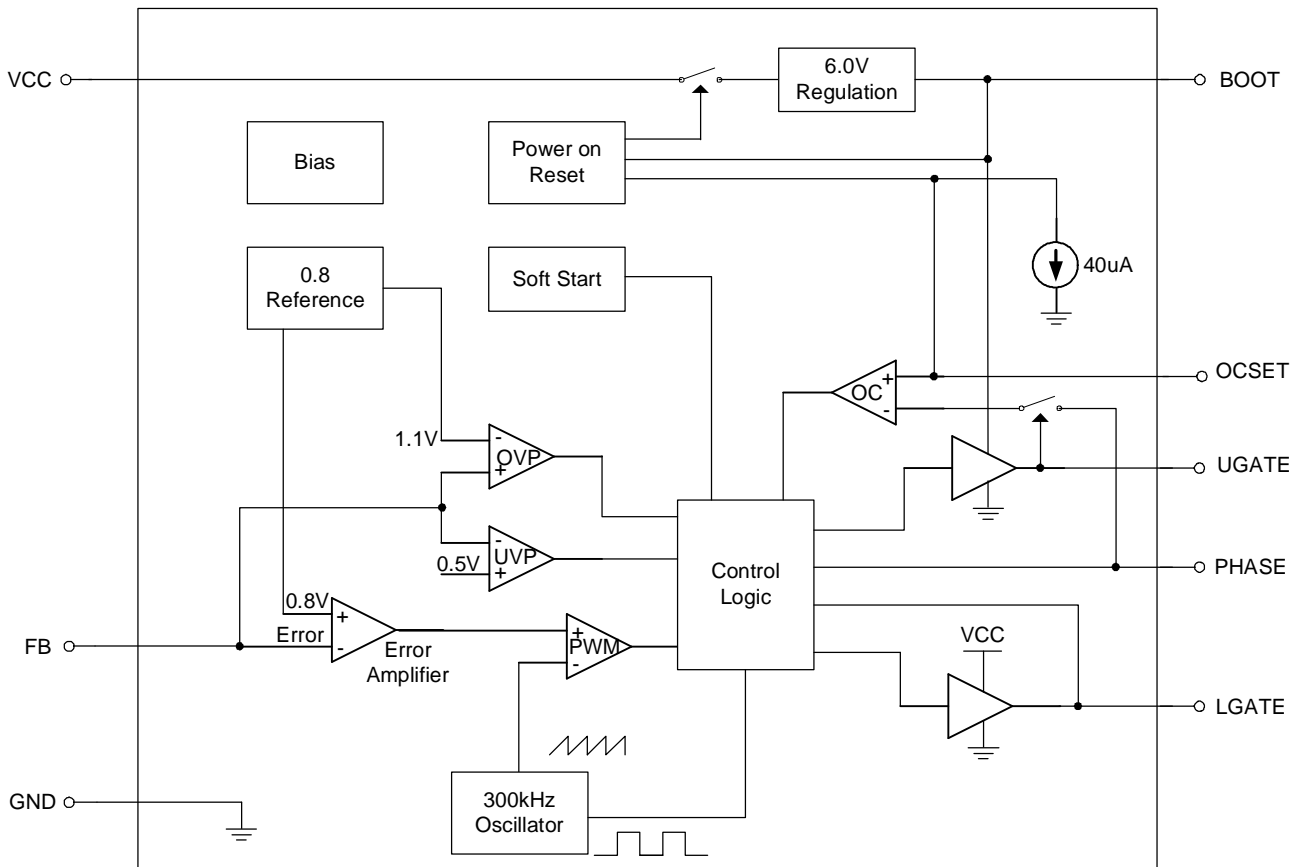

Functional Pin Description

BOOT (Pin 1)

This pin provides ground referenced bias voltage to the upper MOSFET driver. A bootstrap circuit is used to create a voltage suitable to drive a logic-level N-MOSFET when operating at a single 5V power supply. This pin also could be powered from ATX 12V, in this situation, an internal 6.0V regulator will supply to VCC pin for internal voltage bias.

UGATE (Pin 2)

Connect UGATE pin to the PWM converter's upper MOSFET gate. This pin provides the gate drive for the upper MOSFET.

GND (Pin 3)

Signal and power ground for the IC. All voltage levels are measured with respect to this pin.

LGATE (Pin 4)

Connect LGATE to the PWM converter's lower MOSFET gate. This pin provides the gate drive for the lower MOSFET.

VCC (Pin 5)

This is the main bias supply for the RT9202. This pin also provides the gate bias charge for the lower MOSFET gate. The voltage at this pin is monitored for power-on reset (POR) purpose. This pin is also the internal 6.0V regulator output powered from BOOT pin when BOOT pin is directly powered from ATX 12V.

FB (Pin 6)

This pin is connected to the PWM converter's output divider. This pin also connects to internal PWM error amplifier inverting input and protection monitor.

OCSET (Pin 7)

Connect a resistor from this pin to the drain of the upper MOSFET. This resistor, an internal 40 μ A current source, and the upper MOSFET on-resistance set the converter over-current trip point. An over-current trip cycles the soft-start function. The voltage at this pin is monitored for power-on reset (POR) purpose and pulling this pin low with an open drain device will shut down the IC.

$$I_{\text{PEAK}} = \frac{I_{\text{OCSET}} \times R_{\text{OCSET}}}{R_{\text{DS(ON)}}}$$

PHASE (Pin 8)

This pin is used to monitor the voltage drop across the upper MOSFET for over-current protection.

Absolute Maximum Ratings (Note 1)

Supply Input Voltage, V_{CC}	7V
BOOT & UGATE to GND	15V
Input, Output or I/O Voltage	GND – 0.3V to 7V
Power Dissipation, P_D @ $T_A = 25^\circ\text{C}$	
SOP-8	0.625W
Package Thermal Resistance (Note 4)	
SOP-8, θ_{JA}	160°C/W
Ambient Temperature Range	0°C to +70°C
Lead Temperature (Soldering, 10 sec.)	260°C
Storage Temperature Range	–65°C to +150°C
ESD Susceptibility (Note 2)	
HBM (Human Body Mode)	2kV
MM (Machine Mode)	200V

Recommended Operating Conditions (Note 3)

Junction Temperature Range	–40°C to +125°C
----------------------------------	-----------------

Electrical Characteristics

($V_{CC} = 5V$, $T_A = 25^\circ\text{C}$, Unless otherwise specified.)

Parameter	Symbol	Test Conditions	Min	Typ	Max	Units
V_{CC} Supply Current / Regulated Voltage						
Nominal Supply Current	I_{CC}	UGATE, LGATE open	--	3	6	mA
Regulated Voltage from BOOT	V_{CC}	$V_{BOOT} = 12V$	5	6	7	V
Power-On Reset						
Rising V_{CC} Threshold		$V_{OCSET} = 4.5V$	3.85	4.1	4.35	V
V_{CC} Threshold Hysteresis		$V_{OCSET} = 4.5V$	0.3	0.5	0.7	V
Rising V_{OCSET} Threshold			0.8	1.25	2.0	V
Reference						
Reference Voltage			0.784	0.8	0.816	V
Oscillator						
Free Running Frequency			250	300	350	kHz
Ramp Amplitude	ΔV_{OSC}		--	1.75	--	V _{P-P}
Error Amplifier						
DC gain			32	35	38	dB
PWM Controller Gate Driver						
Upper Drive Source	R_{UGATE}	BOOT = 12V BOOT- $V_{UGATE} = 1V$	--	7	11	Ω
Upper Drive Sink	R_{UGATE}	$V_{UGATE} = 1V$	--	5	7.5	Ω
Lower Drive Source	R_{LGATE}	$V_{CC} - V_{LGATE} = 1V$,	--	4	6	Ω
Lower Drive Sink	R_{LGATE}	$V_{LGATE} = 1V$	--	2	4	Ω

To be continued

Parameter	Symbol	Test Conditions	Min	Typ	Max	Units
Protection						
FB Over-Voltage Trip		FB Rising	1.0	1.1	--	V
FB Under-Voltage Trip		FB Falling	--	0.5	0.6	V
OCSET Current Source	IOCSET	VOCSET = 4.5V	35	40	45	μA
Soft-Start Interval			1	2	4	ms

Note 1. Stresses listed as the above "Absolute Maximum Ratings" may cause permanent damage to the device. These are for stress ratings. Functional operation of the device at these or any other conditions beyond those indicated in the operational sections of the specifications is not implied. Exposure to absolute maximum rating conditions for extended periods may remain possibility to affect device reliability.

Note 2. Devices are ESD sensitive. Handling precaution recommended.

Note 3. The device is not guaranteed to function outside its operating conditions.

Note 4. θ_{JA} is measured in the natural convection at $T_A = 25^\circ\text{C}$ on a low effective thermal conductivity test board of JEDEC 51-3 thermal measurement standard.

Typical Operating Characteristic

Dead Time

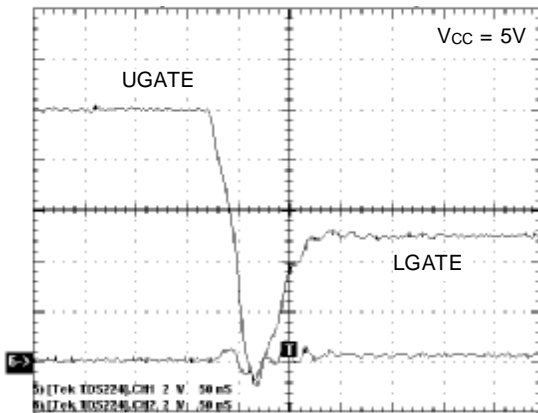

Time (50ns/Div)

Dead Time

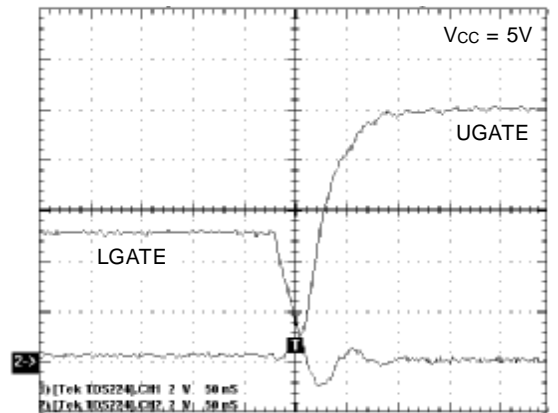

Time (50ns/Div)

Power On

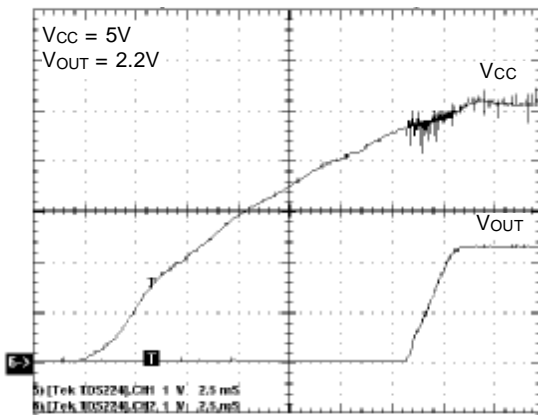

Time (2.5ms/Div)

Power Off

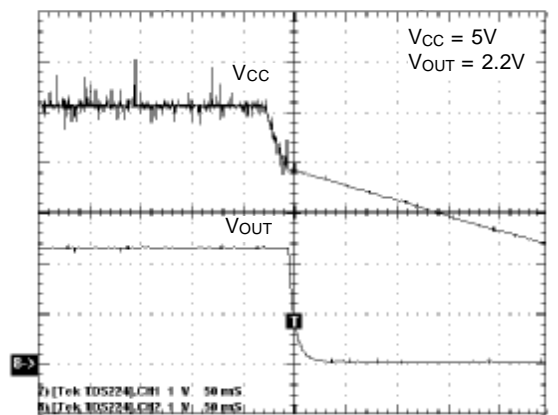

Time (50ms/Div)

Load Transient

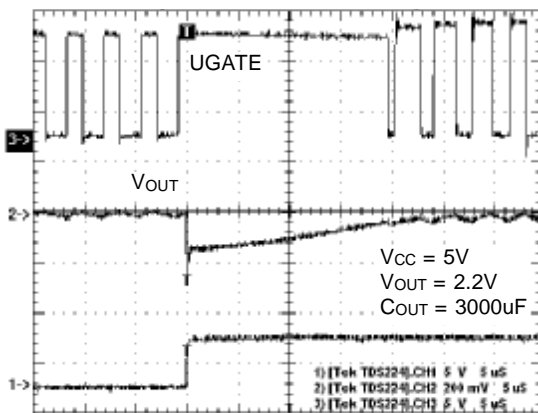

Time (5us/Div)

Load Transient

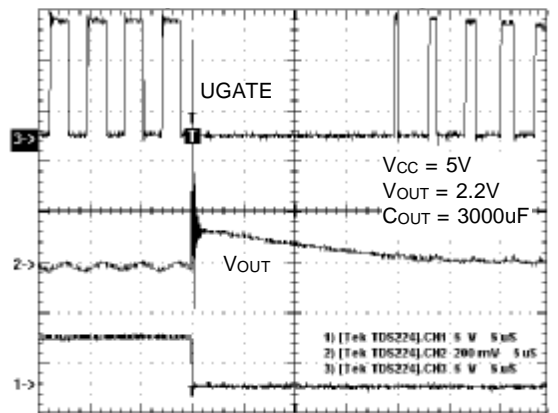

Time (5us/Div)

Bootstrap Wave Form

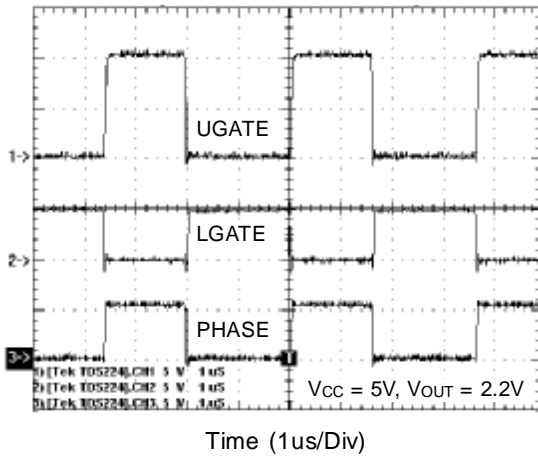

Short Circuit Hiccup

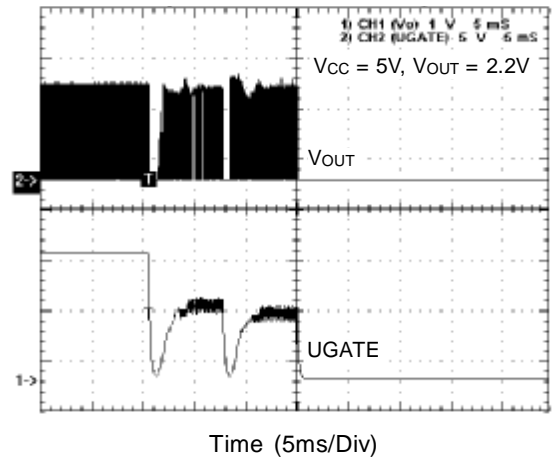

Reference vs. Temperature

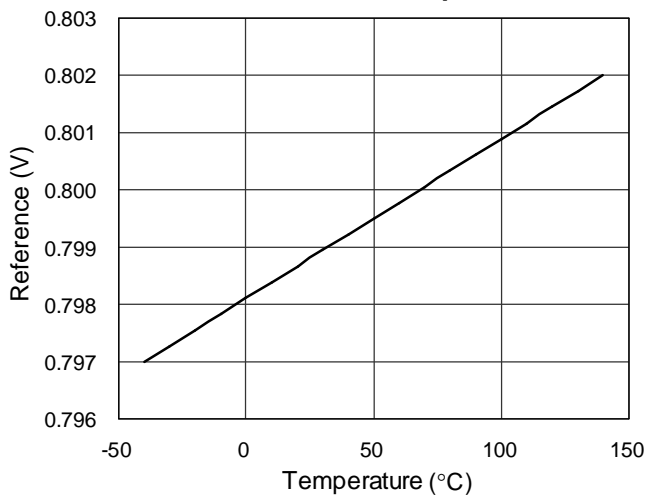

I_{OCSET} vs. Temperature

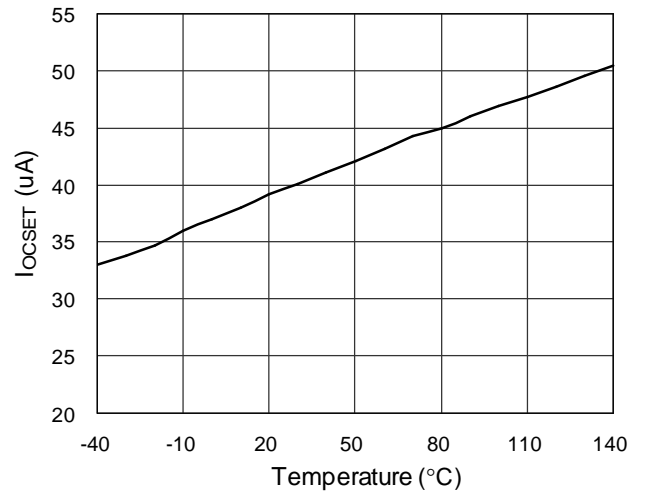

POR (Rising/Falling) vs. Temperature

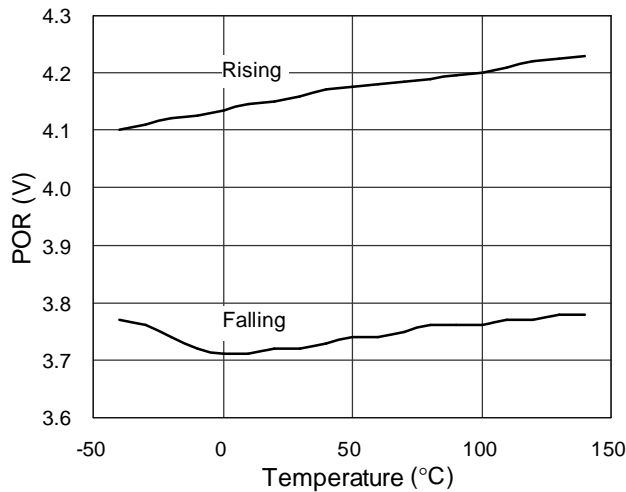

Oscillator Frequency vs. Temperature

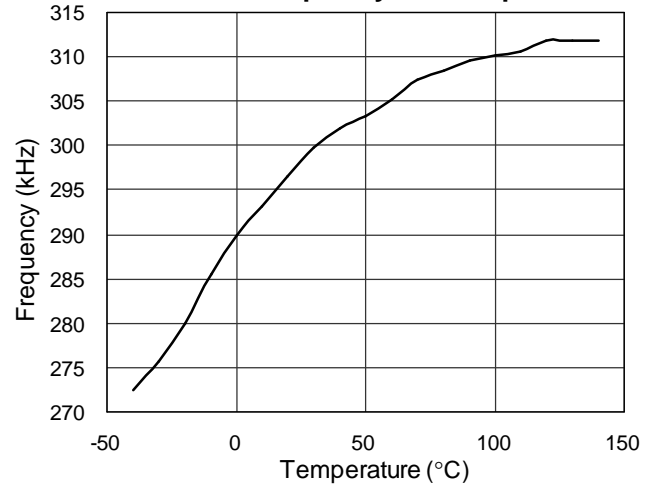

Application Information

The RT9202 operates at either single 5V power supply with a bootstrap UGATE driver or 5V/12V dual-power supply form the ATX SMPS. The dual- power supply is recommended for high current application, the RT9202 can deliver higher gate driving current while operating with ATX SMPS based on dual-power supply.

The Bootstrap Operation

In a single power supply system, the UGATE driver of RT9202 is powered by an external bootstrap circuit, as the Figure 1. The boot capacitor, C_{BOOT} , generates a floating reference at the PHASE pin. Typically a $0.1\mu\text{F}$ C_{BOOT} is enough for most of MOSFETs used with the RT9202. The voltage drop between BOOT and PHASE is refreshed to a voltage of $V_{CC} - \text{diode drop } (V_D)$ while the low side MOSFET turning on.

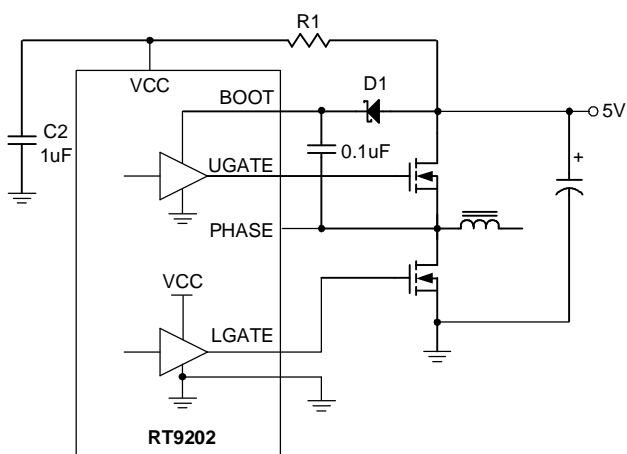

Figure 1. Single 5V power Supply Operation

Dual Power Operation

The RT9202 is designed to regulate a 6.0V at VCC pin automatically when BOOT pin is powered by 12V. In a system with ATX 5V/12V power supply, the RT9202 is ideal for higher current application due to the higher gate driving capability, $V_{UGATE} = 7\text{V}$ and $V_{LGATE} = 6.0\text{V}$. A RC ($10\Omega/1\mu\text{F}$) filter is also recommended at BOOT pin to prevent the ringing induced from fast power on, as shown in Figure 2.

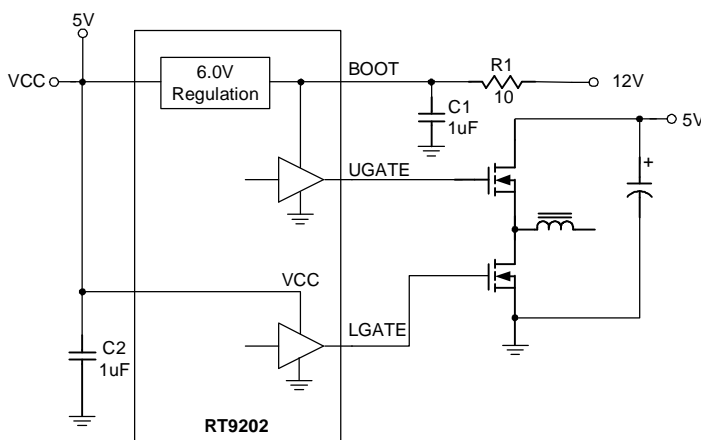

Figure 2. Dual Power Supply Operation

Power On Reset

The Power-On Reset (POR) monitors the supply voltage (normal +5V) at the VCC pin and the input voltage at the OCSET pin. The VCC POR level is 4.1V with 0.5V hysteresis and the normal level at OCSET pin is 1.5V (see over-current protection). The POR function initiates soft-start operation after all supply voltages exceed their POR thresholds.

Soft Start

A built-in soft-start is used to prevent surge current from power supply input during power on. The soft-start voltage is controlled by an internal digital counter. It clamps the ramping of reference voltage at the input of error amplifier and the pulse-width of the output driver slowly. The typical soft-start duration is 2ms.

Over-Current Protection

The over current protection (OCP) function of the RT9202 is triggered when the voltage across the $R_{DS(ON)}$ of upper side MOSFET that developed by drain current exceeds over-current tripping level. An external resistor (R_{OCSET}) programs the over-current tripping level of the PWM converter. As shown on Figure 3 the internal $40\mu\text{A}$ current sink (I_{OCSET}) develops a voltage across R_{OCSET} (V_{SET}) that is referenced to V_{IN} . The DRIVE signal enables the over-current comparator (OC). When the voltage across the upper MOSFET ($V_{DS(ON)}$) exceeds V_{SET} , the over-current comparator trips to set the over-current latch.

Both V_{SET} and V_{DS} are referenced to V_{IN} and a small capacitor across R_{OCSET} helps V_{OCSET} tracking the variations of V_{IN} due to MOSFET switching. The over-current function will be tripped at a peak inductor current (I_{PEAK}) determined by :

$$I_{PEAK} = \frac{I_{OCSET} \times R_{OCSET}}{R_{DS(ON)}}$$

The OC trip point varies with MOSFET's $R_{DS(ON)}$ temperature variations. The temperature coefficient of I_{OCSET} is 2500ppm that is used to compensate $R_{DS(ON)}$ temperature variations. To avoid over-current tripping in the normal operating load range, determine the R_{OCSET} resistor value from the equation above with:

- 1.The maximum $R_{SD(ON)}$ at the highest junction temperature
- 2.The minimum I_{OCSET} from the characteristics
- 3.Determine I_{PEAK} for $I_{PEAK} > I_{OUT(MAX)} + (\Delta I)/2$ where ΔI is the output inductor ripple current.

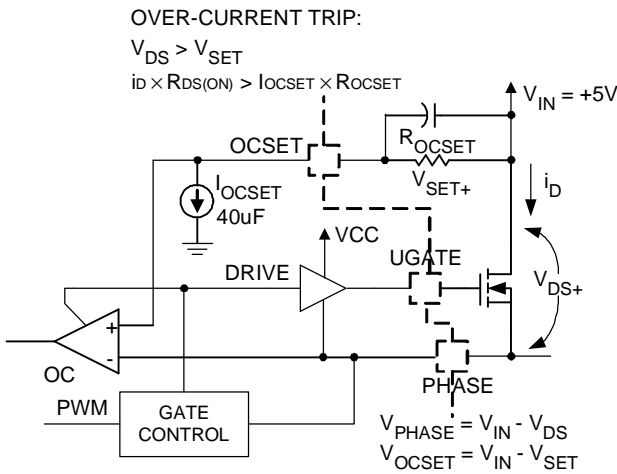

Figure 3

Under Voltage and Over Voltage Protection

The voltage at FB pin is monitored and protected against OC (over current), UV (under voltage), and OV (over voltage). The UV threshold is 0.5V and OV-threshold is 1.0V. Both UV/OV detection have 30μs triggered delay. When OC or UV triggered, a hiccup re-start sequence will be initialized, as shown in Figure 4. Only 3 times of trigger are allowed to latch off. Hiccup is disabled during soft-start interval.

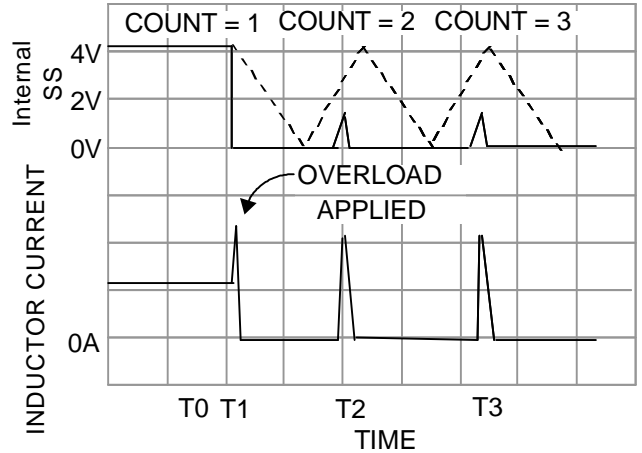

Figure 4

Shutdown

Pulling low the OCSET pin can shutdown the RT9202 PWM controller as shown in typical application circuit.

Inductor Selection

The RT9202 was designed for $V_{IN} = 5V$, step-down application mainly. Figure 5 shows the typical topology and waveforms of step-down converter.

The ripple current of inductor can be calculated as follows:

$$I_{L(RIPPLE)} = (5V - V_{OUT})/L \times T_{ON}$$

Because operation frequency is fixed at 300kHz,

$$T_{ON} = 3.33 \times V_{OUT}/5V$$

The V_{OUT} ripple is

$$V_{OUT(RIPPLE)} = I_{L(RIPPLE)} \times ESR$$

ESR is output capacitor equivalent series resistor

Table 1 shows the ripple voltage of V_{OUT} : $V_{IN} = 5V$

Table 1

V _{OUT}	3.3V		2.5V		1.5V	
Inductor	2μH	5μH	2μH	5μH	2μH	5μH
1000μF (ESR=53mΩ)	100mV	40mV	110mV	44mV	93mV	37mV
1500μF (ESR=33mΩ)	62mV	25mV	68mV	28mV	58mV	23mV
3000μF (ESR=21mΩ)	40mV	16mV	43mV	18mV	37mV	15mV

*Refer to Sanyo low ESR series (CE, DX, PX.....)

The suggested L and C are as follows:

2μH with ≥ 1500μF C_{OUT}

5μH with ≥ 1000μF C_{OUT}

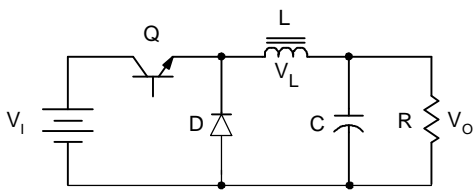

C.C.M

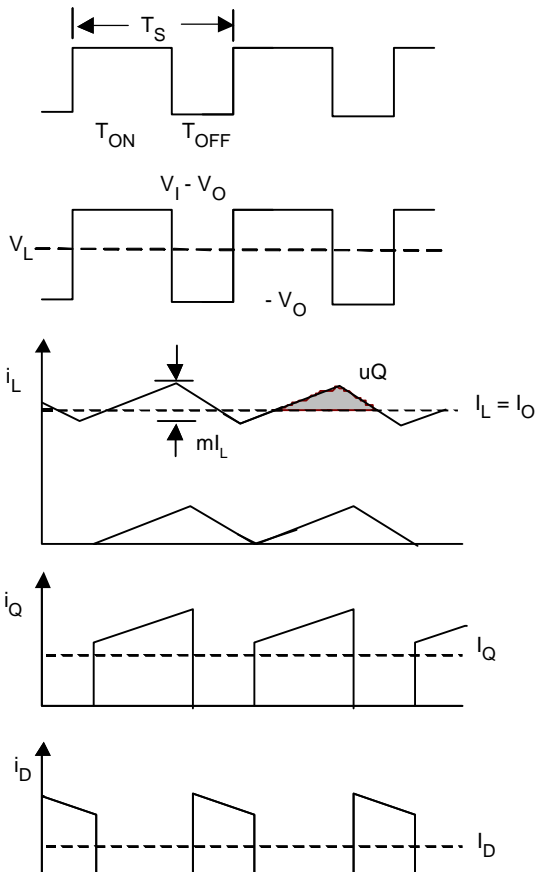

Figure 5

Input / Output Capacitor

High frequency/long life decoupling capacitors should be placed as close to the power pins of the load as physically possible. Be careful not to add inductance to the PCB trace, as it could eliminate the performance from utilizing these low inductance components. Consult with the manufacturer of the load on specific decoupling requirements.

The output capacitors are necessary for filtering output and stabilizing the close loop (see the PWM loop stability). For powering advanced, high-speed processors, it is required to meet with the requirement of fast load transient, high frequency capacitors with low ESR/ESL capacitors are recommended.

Another concern is high ESR induced ripple may trigger UV or OV protections.

PWM Loop Stability

The RT9202 is a voltage mode buck controller designed for 5V step-down applications. The gain of error amplifier is fixed at 35dB for simplified design.

The output amplitude of ramp oscillator is 1.75V, the loop gain and loop pole/zero are calculated as follows :

$$DC \text{ loop gain } G_A = 35dB \times \frac{5}{1.75} \times \frac{0.8}{V_{OUT}}$$

$$LC \text{ filter pole } P_O = \frac{1}{2p\sqrt{LC}}$$

$$\text{Error Amp pole } P_A = 300kHz$$

$$\text{ESR zero } Z_O = \frac{1}{2p \text{ ESR}C}$$

The RT9202 Bode plot as shown Figure 6 is stable in most of application conditions.

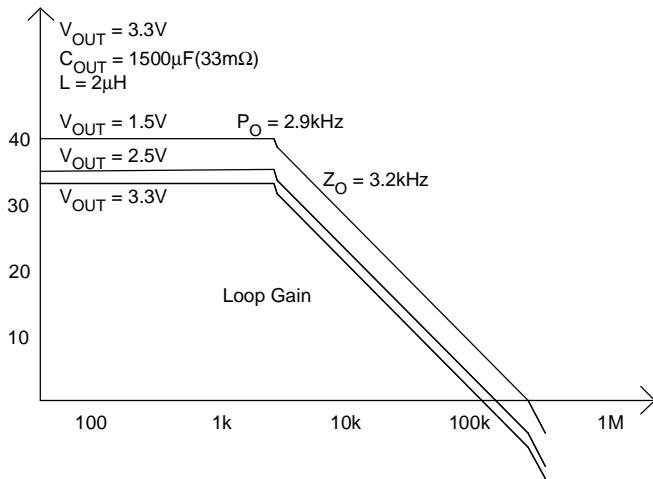

Figure 6

Reference Voltage

Because RT9202 use a low 35dB gain error amplifier, shown in Figure 7. The voltage regulation is dependent on V_{IN} & V_{OUT} setting. The FB reference voltage of 0.8V were trimmed at $V_{IN} = 5V$ & $V_{OUT} = 2.5V$ condition. In a fixed $V_{IN} = 5V$ application, the FB reference voltage vs. V_{OUT} voltage can be calculated as Figure 8.

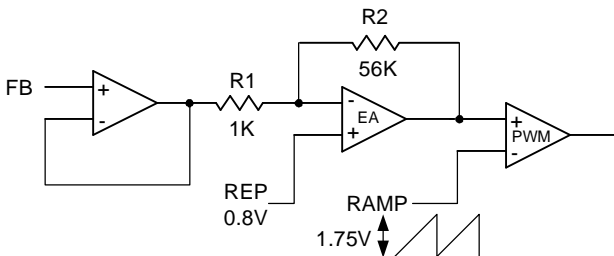

Figure 7

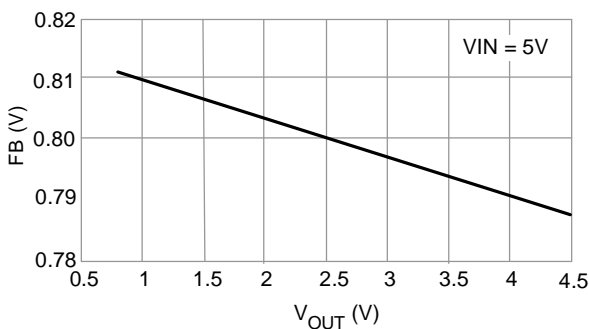

Figure 8

Feedback Divider

The reference of RT9202 is 0.8V. The output voltage can be set using a resistor based divider as shown in Figure 9. Put the R1 and R2 as close as possible to FB pin and R2 should less than 1 kΩ to avoid noise coupling. The C1 capacitor is a speed-up capacitor for reducing output ripple to meet with the requirement of fast transient load. Typically a 1nF to 0.1µF is enough for C1.

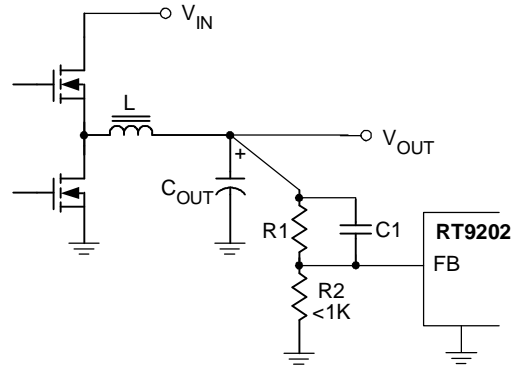

Figure 9

PWM Layout Considerations

MOSFETs switch very fast and efficiently. The speed with which the current transitions from one device to another causes voltage spikes across the interconnecting impedances and parasitic circuit elements. The voltage spikes can degrade efficiency and radiate noise, that results in over-voltage stress on devices. Careful component placement layout and printed circuit design can minimize the voltage spikes induced in the converter. Consider, as an example, the turn-off transition of the upper MOSFET prior to turn-off, the upper MOSFET was carrying the full load current. During turn-off, current stops flowing in the upper MOSFET and is picked up by the low side MOSFET or Schottky diode. Any inductance in the switched current path generates a large voltage spike during the switching interval. Careful component selections, layout of the critical components, and use shorter and wider PCB traces help in minimizing the magnitude of voltage spikes.

There are two sets of critical components in a DC-DC converter using the RT9202. The switching power components are most critical because they switch large amounts of energy, and as such, they tend to generate equally large amounts of noise. The critical small signal components are those connected to sensitive nodes or those supplying critical bypass current.

The power components and the PWM controller should be placed firstly. Place the input capacitors, especially the high-frequency ceramic decoupling capacitors, close to the power switches. Place the output inductor and output capacitors between the MOSFETs and the load. Also locate the PWM controller near by MOSFETs.

A multi-layer printed circuit board is recommended. Figure 10 shows the connections of the critical components in the converter. Note that the capacitors CIN and COUT each of them represents numerous physical capacitors. Use a dedicated grounding plane and use vias to ground all critical components to this layer. Apply another solid layer as a power plane and cut this plane into smaller islands of common voltage levels. The power plane should support the input power and output power nodes. Use copper filled polygons on the top and bottom circuit layers for the PHASE node, but it is not necessary to oversize this particular island. Since the PHASE node is subjected to very high dV/dt voltages, the stray capacitance formed between these island and the surrounding circuitry will tend to couple switching noise. Use the remaining printed circuit layers for small signal routing. The PCB traces between the PWM controller and the gate of MOSFET and also the traces connecting source of MOSFETs should be sized to carry 2A peak currents.

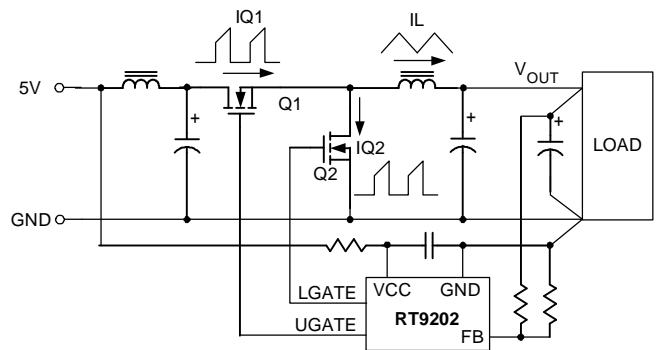
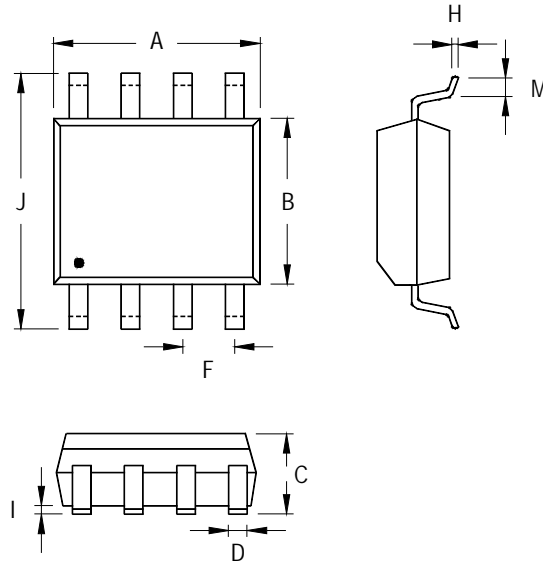

Figure 10

Outline Dimension



Symbol	Dimensions In Millimeters		Dimensions In Inches	
	Min	Max	Min	Max
A	4.801	5.004	0.189	0.197
B	3.810	3.988	0.150	0.157
C	1.346	1.753	0.053	0.069
D	0.330	0.508	0.013	0.020
F	1.194	1.346	0.047	0.053
H	0.170	0.254	0.007	0.010
I	0.050	0.254	0.002	0.010
J	5.791	6.200	0.228	0.244
M	0.400	1.270	0.016	0.050

8-Lead SOP Plastic Package

Richtek Technology Corporation

Headquarter
 5F, No. 20, Taiyuen Street, Chupei City
 Hsinchu, Taiwan, R.O.C.
 Tel: (8863)5526789 Fax: (8863)5526611

Richtek Technology Corporation

Taipei Office (Marketing)
 8F, No. 137, Lane 235, Paochiao Road, Hsintien City
 Taipei County, Taiwan, R.O.C.
 Tel: (8862)89191466 Fax: (8862)89191465
 Email: marketing@richtek.com