

VI TELEFILTER**Filter specification****TFS 35A****1/5****1. Measurement condition :**

Ambient temperature T_A :	25 °C	
Input power level:	0 dBm	
Terminating impedances in f_C *):	for input: 310 Ω -25,7 pF.	
	for output: 690 Ω -10,1 pF.	
Source impedance .	50 Ω .	
Load impedance .	50 Ω .	

2. Characteristics :

Remark: Reference level for the relative attenuation a_{rel} of the TFS 35A is the minimum of the pass band attenuation a_{min} . The minimum of the pass band attenuation a_{min} is defined as the insertion loss a_e . The reference frequency f_C is the arithmetic mean value of the upper and lower frequencies at the 3 dB filter attenuation level relative to the insertion loss a_e . The nominal frequency f_N is fixed at 35,42 MHz without tolerance. All specified values are guaranteed in operating temperature range. Measurement of filter response will be done at temperatures of -40°C , 25°C and 85°C for each part.

D a t a	typ. value	tolerance / limit
Insertion loss (Reference level) a_e	14,8 dB	max. 17 dB
Nominal frequency f_N	-	35,42 MHz
Centre frequency f_C at ambient temperature (f_{CTA})	35,42 MHz	-
Pass band : PB		$f_C \dots f_C \pm 0,80$ MHz
Amplitude ripple in PB (p-p) :	0,6 dB	max. 1,6 dB
Bandwidth : BW		
1 dB	2,01 MHz	min. 1,7 MHz
3 dB	2,44 MHz	-
21 dB	3,32 MHz	max. 3,74 MHz
Relative attenuation in O.T.R. : a_{rel}		
34,62 MHz ... 36,22 MHz	0,8 dB	max. 1,6 dB
0,1 MHz ... 7 MHz	55...27 dB	-
7 MHz ... 28 MHz	55...50 dB	min. 35 dB
28 MHz ... 31 MHz	35 dB	min. 30 dB
31 MHz ... 33,5 MHz	40...30 dB	min. 21 dB
37,34 MHz ... 39,84 MHz	27...42 dB	min. 21 dB
39,84 MHz ... 62,42 MHz	45...60 dB	min. 35 dB
62,42 MHz ... 72,42 MHz	36 dB	min. 30 dB
72,42 MHz ... 110,42 MHz	70...80 dB	min. 40 dB
Group delay (mean value in PB):	1,4 μ s	max. 1,7 μ s
Group delay ripple in PB (p-p) :	200 ns	max. 300 ns
Deviation from linear phase in PB (p-p) :	± 2 degree	-
Triple transit attenuation compared to main signal	35 dB	
Crosstalk attenuation compared to main signal	50 dB	
Temperature coefficient of frequency (Tc_f)	- 20 ppm/K	-
Frequency deviation of f_C over temperature	$\Delta f_C(\text{Hz}) = Tc_f(\text{ppm/K}) \times (T - T_A) \times f_{CTA}(\text{MHz})$	-
Operating temperature range (O.T.R.)	-	- 40 °C ... + 85 °C
Storage temperature range	-	- 55 °C ... + 125 °C

*) The terminating impedances depend on parasitics and q-values of matching elements and the board used, and are to be understood as reference values only. Should there be additional questions do not hesitate to ask for an application note or contact our design team.

Generated: _____**Checked / approved:** _____

TELEFILTER GmbH
Potsdamer Straße 18
D 14 513 TELTOW / Germany
Tel: (+49) 3328 4784-0 / Fax: (+49) 3328 4784-30
E-Mail: tft@telefilter.com

VI TELEFILTER reserves the right to make changes to the product(s) and/or information contained herein without notice. No liability is assumed as a result of their use or application. No rights under any patent accompany the sale of any such product(s) or information.

3. Package and pin connection : (All dimensions in mm)

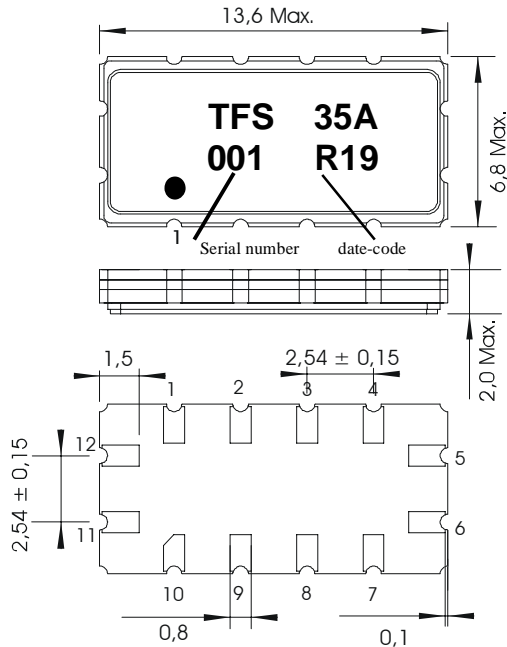

date -code: year + week
 N 2001
 P 2002
 R 2003

Unbalanced :

Pin 11 **Input**
 Pin 12 **Input RF Return**
 Pin 5 **Output**
 Pin 6 **Output RF Return**
 Pin 1-4, 7-10 **Package Ground**

Balanced :

Pin 11 **Input**
 Pin 12 **Input**
 Pin 5 **Output**
 Pin 6 **Output**
 Pin 1-4, 7-10 **Package Ground**

4.1 50 Ω matching network (for details refer to application note):

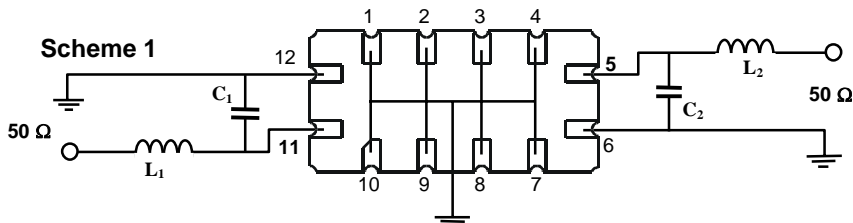

4.2 Matching network for 500 Ω x 1000 Ω (for details refer to application note) :

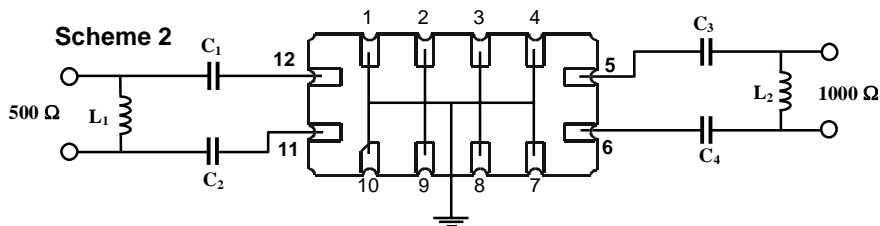

For final test we use scheme 1.

TELEFILTER GmbH
 Potsdamer Straße 18
 D 14 513 TELTOW / Germany
 Tel: (+49) 3328 4784-0 / Fax: (+49) 3328 4784-30
 E-Mail: tft@telefilter.com

VI TELEFILTER reserves the right to make changes to the product(s) and/or information contained herein without notice. No liability is assumed as a result of their use or application. No rights under any patent accompany the sale of any such product(s) or information.

5.1. 100% Screening Tests :

After the following tests the filter shall meet the whole specification. Electrical tests after test 4, test 5 and 7.

1. Internal Visual Inspection: according to MIL-STD-883 method 2017
2. Stabilization Bake: 16 hrs at 125°C under Vacuum according to MIL-STD-883 Method 1008 Condition B
3. Temperature Cycling: -55 °C to 125°C / 30 min. each / 10 cycles
DIN IEC 68 part 2 – 14 Test N equivalent MIL-STD-202 Method 107
4. Shock: 500g, 18 ms, half sine wave, 3 shocks each plane;
DIN IEC 68 T2 - 27
5. Burn-in: 160hrs at 125°C (no input power) according to MIL-STD-883 Method 1015
6. Seal test: gross leak bubble test – Fluorocarbon liquid at 125°C ± 5°C
MIL-STD-202 Method 112 Condition D
Fine leak spot test – Helium detector according to MIL-STD-202 Method 112 Condition C
7. External Visual Inspection: according to MIL-STD-883 method 2009

5.2. Qualification Tests :

1. Resistance to solder heat (reflow): reflow possible: twice max.;
for temperature conditions refer to the attached "Air reflow temperature conditions" on page 4;
2. Vibration: 10 Hz to 500 Hz, 0,35 mm or 5g respectively, 1 octave per min, 10 cycles per plan, 3 plans;
DIN IEC 68 T2 – 6
3. Life test: storage of 2 pcs for 1000 hrs at 125°C (no input power) MIL-STD-883 Method 1005. The test will be done using samples which were handled according to point 5.1.

6. Packing :

Tape & Reel: DIN IEC 286 - 3, with exception of value for N and minimum bending radius;
tape type II, embossed carrier tape with top cover tape on the upper side;

max. pieces of filters per reel:	1700
reel of empty components at start:	min 300 mm
reel of empty components at start including leader:	min 500 mm
Trailer	min 300 mm

Tape (all dimensions in mm)

W	: 24 ± 0,3
Po	: 4 ± 0,1
Do	: 1,5 + 0,1
E	: 1,75 ± 0,1
F	: 11,5 ± 0,1
G (min)	: 0,6
P2	: 2 ± 0,1
P1	: 12 ± 0,1
D1(min)	: 1,5
Ao	: 7,1 ± 0,2
Bo	: 13,9 ± 0,2
CT	: 21,5 ± 0,1

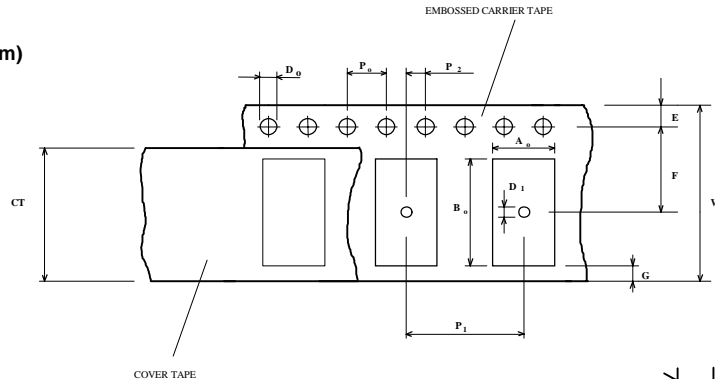
**Reel (all dimensions in mm):**

A	: 330
W1	: 24,4 + 2
W2(max)	: 30,4
N(min)	: 60
C	: 13 +0,5/-0,2

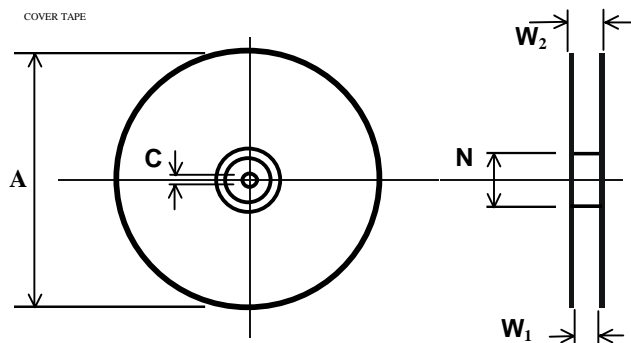

The minimum bending radius is 45 mm. The mounting surface of the filters faces the bottom side of the embossed carrier tape. Markings on the filters can be read if the upper side of the carrier tape is regarded with the sprocket holes on its right.

TELEFILTER GmbH
Potsdamer Straße 18
D 14 513 TELTOW / Germany
Tel: (+49) 3328 4784-0 / Fax: (+49) 3328 4784-30
E-Mail: tft@telefilter.com

VI TELEFILTER reserves the right to make changes to the product(s) and/or information contained herein without notice. No liability is assumed as a result of their use or application. No rights under any patent accompany the sale of any such product(s) or information.

7. Air reflow temperature conditions :

1st and 2nd air reflow profile

Name:	pre-heating periods	main-heating periods	peak temperature
Temperature:	150 °C - 170 °C	over 200 °C	255 °C ± 5 °C
Time:	60 sec. - 90 sec.	20 sec. - 25 sec.	

Air reflow profile

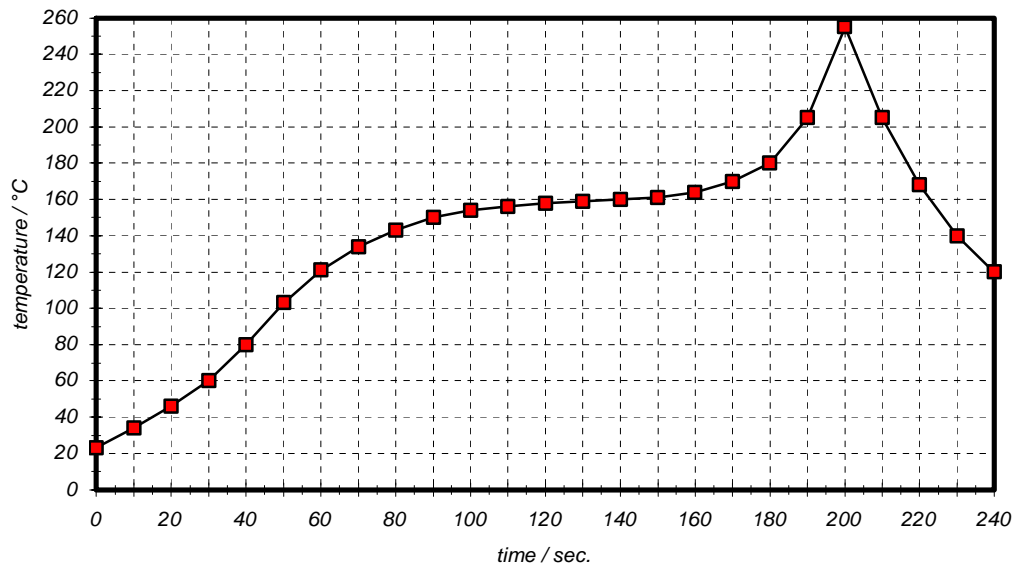

Table for temperature vs. time during the air reflow process

Tolerance of temperatures: ± 5 °C

time / sec.	temperature / °C	time / sec.	temperature / °C
0	23	140	160
10	34	150	161
20	46	160	164
30	60	170	170
40	80	180	180
50	103	190	205
60	121	195	230
70	134	200	255
80	143	205	230
90	150	210	205
100	154	215	180
110	156	220	165
120	158	230	140
130	159	240	120

TELEFILTER GmbH
 Potsdamer Straße 18
 D 14 513 TELTOW / Germany
 Tel: (+49) 3328 4784-0 / Fax: (+49) 3328 4784-30
 E-Mail: tft@telefilter.com

VI TELEFILTER reserves the right to make changes to the product(s) and/or information contained herein without notice. No liability is assumed as a result of their use or application. No rights under any patent accompany the sale of any such product(s) or information.

8. History

Version	Reason of changes	Name	Date
1.0	- Generate development specification according customer requirements.	Dunzow W.	23.01.2003
1.1	- Change storage temperature range. - Add information about measured temperatures.	Dunzow W.	07.02.2003
1.2	- Add further test to stability characteristics. - Add serial number to marking.	T. Kirschner	24.02.2003
1.3	- Change Paragraph 5.1 to 5.2 and wise versa - Change the quantity mentioned in 5.2.3 from 15pcs. to 2pcs. - Guarantee to use samples having 100% screening test for test 5.2.3	B. Küppers	27.02.2003
1.4	- Change from development specification to filter specification. - Add termination impedances and typical values.	Dr. Wall	06.05.2003