

TOSHIBA BIPOLAR LINEAR INTEGRATED CIRCUIT SILICON MONOLITHIC

# TA8026AP

## FLASHER CONTROLLER

The TA8026AP is designed as an automotive flasher controller. It can issue a rapid-flashing warning when a lamp failure occurs.

It operates accurately in wide ranges of supply voltages and operating temperatures. It incorporates an accurate reference voltage circuit which compensates for lamp current characteristic variations due to supply voltage changes.

- Large output current :  $I_{OUT} = 300\text{mA}$  (Max.)
- Low standby current :  $I_{CC} = 1.0\text{mA}$  (Typ.)
- Reference voltage characterized by small temperature drift.
- Built-in circuit that compensates for variations in lamp voltage characteristics.
- Output from combination of PNP and NPN transistors with suppression diode.
- Wide operating temperature :  $T_a = -40$  to  $110^\circ\text{C}$
- DIP - 8 pin.

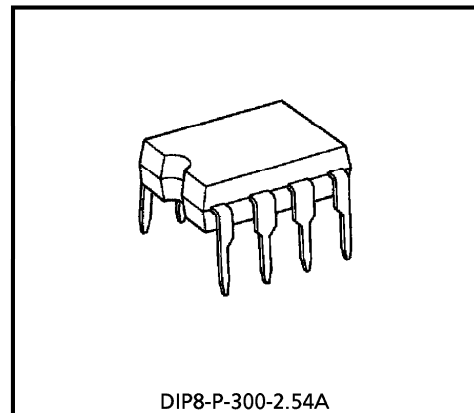

DIP8-P-300-2.54A

Weight : 0.45g (Typ.)

### BLOCK DIAGRAM AND PIN LAYOUT

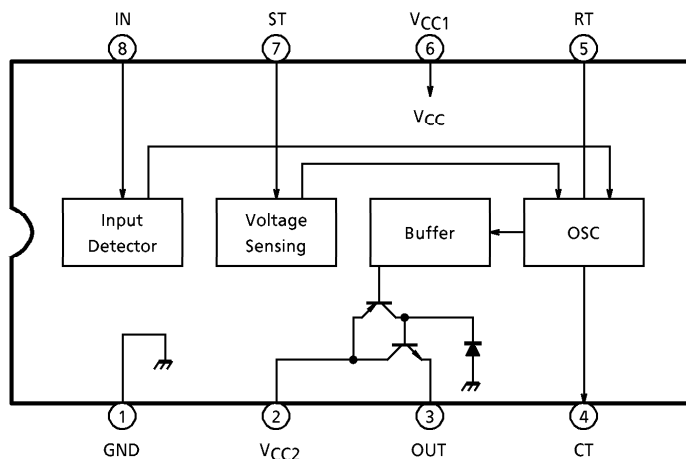

961001EBA2

- TOSHIBA is continually working to improve the quality and the reliability of its products. Nevertheless, semiconductor devices in general can malfunction or fail due to their inherent electrical sensitivity and vulnerability to physical stress. It is the responsibility of the buyer, when utilizing TOSHIBA products, to observe standards of safety, and to avoid situations in which a malfunction or failure of a TOSHIBA product could cause loss of human life, bodily injury or damage to property. In developing your designs, please ensure that TOSHIBA products are used within specified operating ranges as set forth in the most recent products specifications. Also, please keep in mind the precautions and conditions set forth in the TOSHIBA Semiconductor Reliability Handbook.
- The products described in this document are subject to foreign exchange and foreign trade control laws.
- The information contained herein is presented only as a guide for the applications of our products. No responsibility is assumed by TOSHIBA CORPORATION for any infringements of intellectual property or other rights of the third parties which may result from its use. No license is granted by implication or otherwise under any intellectual property or other rights of TOSHIBA CORPORATION or others.
- The information contained herein is subject to change without notice.

**PIN DESCRIPTION**

PIN No.	SYMBOL	DESCRIPTION
1	GND	Grounded
2	V <sub>CC2</sub>	Power supply pin (2)
3	OUT	Open-emitter output of complementary combination of PNP and NPN transistors.
4	CT	A capacitor is connected between V <sub>CC</sub> and CT. This layout determines the flashing interval of the flasher.
5	RT	A resistor is connected between RT and CT. This layout determines the flashing interval of the flasher.
6	V <sub>CC1</sub>	Power supply pin (1)
7	ST	Current detection pin. The lamp current is detected through a shunt resistor connected between V <sub>CC1</sub> and ST.
8	IN	Detection pin for lamp operation.

**TIMING CHART**

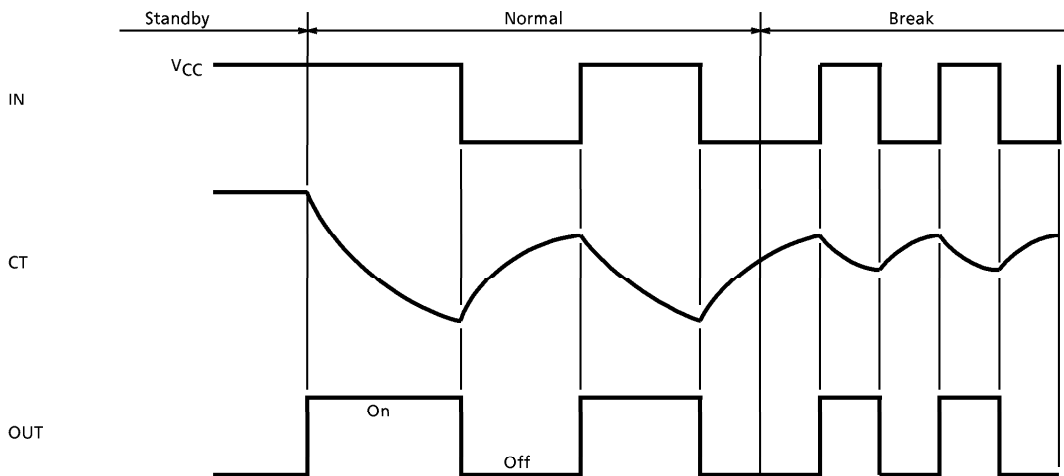

**MAXIMUM RATINGS (Ta = 25°C)**

CHARACTERISTIC	SYMBOL	RATING	UNIT
Supply Voltage	V <sub>CC</sub>	28	V
Power Dissipation	P <sub>D</sub>	300 *	mW
Output Current	I <sub>OUT</sub>	300	mA
Input Voltage	V <sub>IN</sub>	-0.3~V <sub>CC</sub>	V
Operating Temperature	T <sub>opr</sub>	-40~110	°C
Storage Temperature	T <sub>stg</sub>	-55~150	°C
Lead Temperature-time	T <sub>sol</sub>	260 (10s)	°C

\* Ta ≤ 110°C

**ELECTRICAL CHARACTERISTICS (V<sub>CC</sub> = 12V, Ta = -40 to 110°C)**

CHARACTERISTIC	SYMBOL	PIN	TEST CONDITION	MIN.	TYP.	MAX.	UNIT
Operating Voltage	V <sub>opr</sub>	V <sub>CC</sub>		6	—	18	A
Current Consumption	I <sub>CC</sub>	GND	Standby, Ta = 25°C	0.6	0.9	1.4	mV
			Output on, Ta = 25°C	2.5	4.0	6.0	
Output Voltage	V <sub>OH</sub>	OUT	R <sub>L</sub> = 82Ω	—	—	1.3	V
Leakage Current	I <sub>LEAK</sub>	OUT	V <sub>OUT</sub> = 0V	-100	—	—	μA
Input Current	I <sub>IN</sub>	CT	V <sub>IN</sub> = V <sub>CC</sub> ~ V <sub>CC</sub> - 5V	-10	—	10	μA
		ST	V <sub>IN</sub> = V <sub>CC</sub>	-10	—	10	
		IN	V <sub>IN</sub> = 12V	—	—	20	mA
			V <sub>IN</sub> = 0V	-1.5	-2.5	-3.5	
Input Voltage	V <sub>IL</sub>	IN		—	—	0.4	× V <sub>CC</sub>
	V <sub>IH</sub>		0.6	—	—		
Detection Voltage	V <sub>TH</sub>	ST	V <sub>CC</sub> = 8V	16	21	26	mV
			V <sub>CC</sub> = 11V	25	31	37	
			V <sub>CC</sub> = 14V	30	36	42	
	ΔV <sub>TH</sub> /T			-60	—	60	μV/°C
	ΔV <sub>TH</sub> /ΔV <sub>CC</sub>			2.7	3.3	3.9	mV/V
Condition Detect Voltage	*1 V <sub>THO</sub>	ST	V <sub>CC</sub> = 8V	3	7	11	mV
			V <sub>CC</sub> = 11V	5	10	15	
			V <sub>CC</sub> = 16V	8	13	18	
Flashing Interval		OUT	C <sub>T</sub> = 3.3μF, R <sub>T</sub> = ADJ *2	690	706	723	ms
Flashing Interval (At fail detection)		OUT		315	324	333	
On Duty		OUT		45	50	55	%
On Duty (At fail detection)		OUT		30	—	50	

\*1 : The minimum detection voltage to be able to operate.

\*2 : Adjust the flashing interval to 706ms by changing R<sub>T</sub> while keeping C<sub>T</sub> = 3.3μF at room temperature.

FLASHING FREQUENCY CHARACTERISTICS

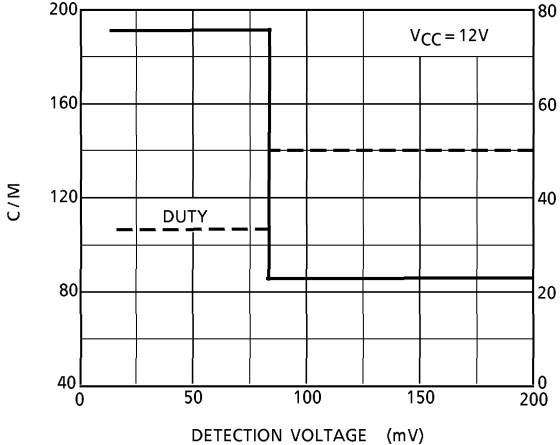

DETECTION VOLTAGE CHARACTERISTICS

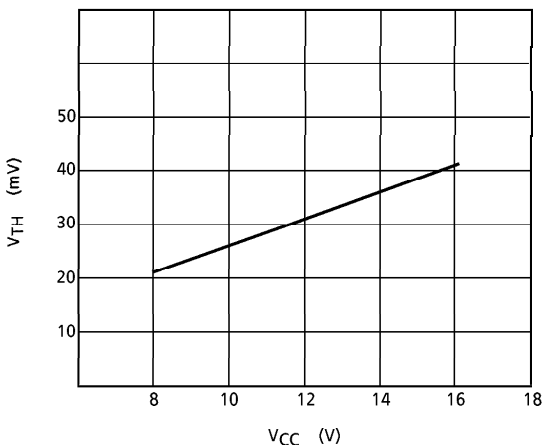

EXAMPLE OF APPLICATION CIRCUIT

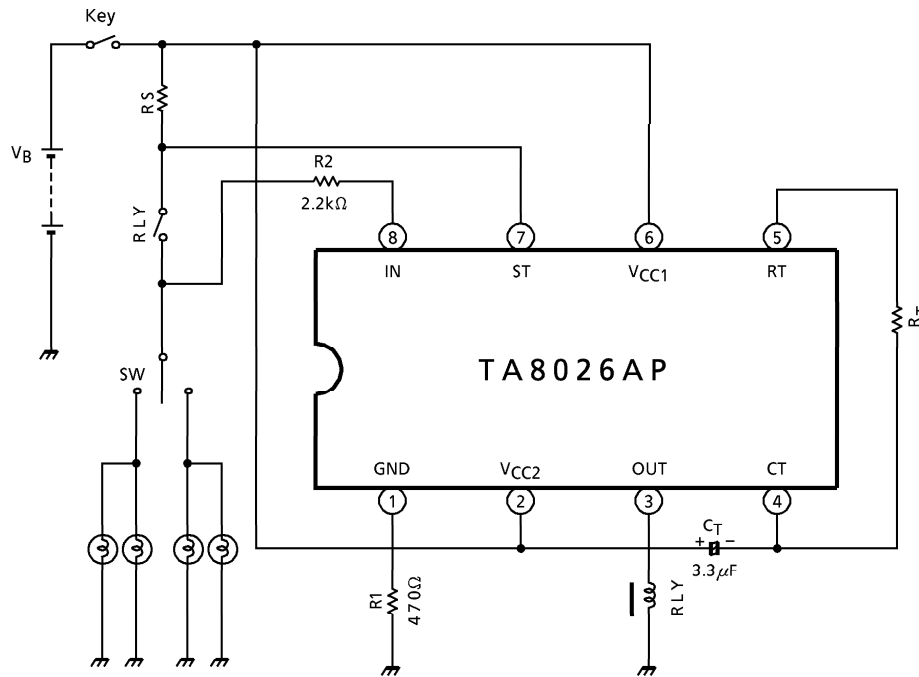

Note : The tolerance of R1 and R2 is within  $\pm 5\%$ .

OUTLINE DRAWING  
DIP8-P-300-2.54A

Unit : mm

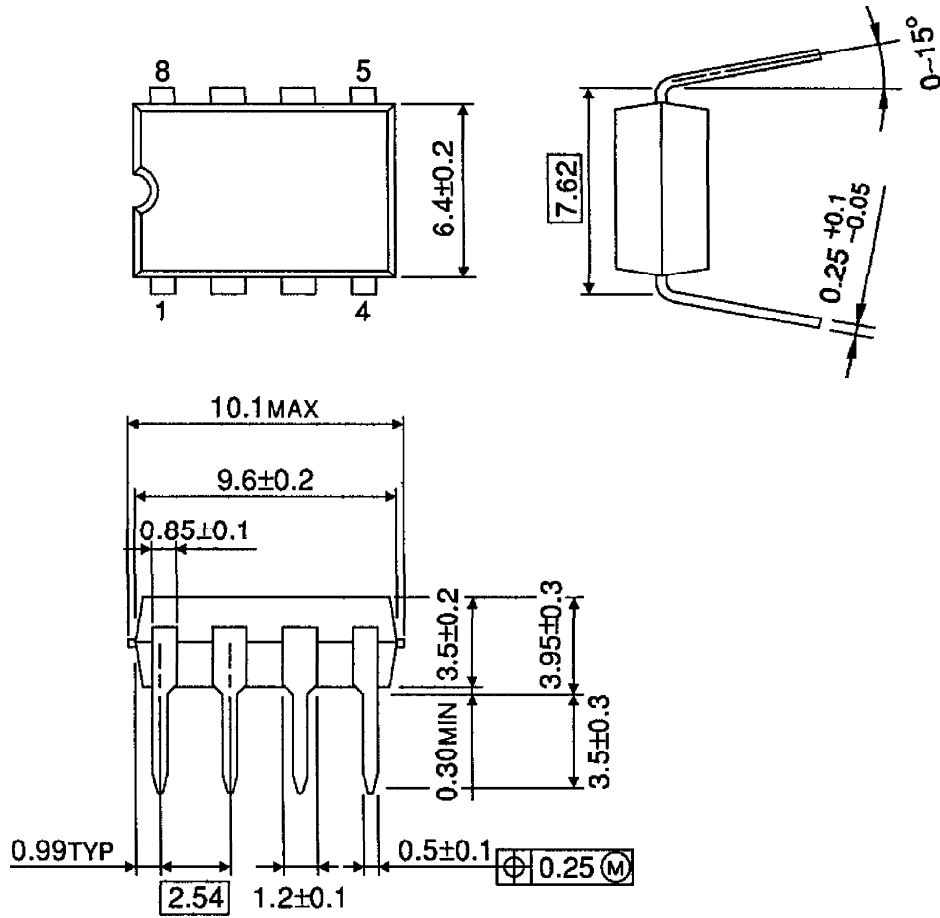

Weight : 0.45g (Typ.)