

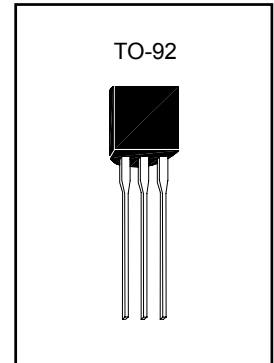

100mA Low Dropout Voltage Regulators

PL2950-XXA3



FEATURES

- Battery powered systems
- Cordless telephones
- Radio control systems
- Portable/Palm top/Notebook computers
- Portable consumer equipment
- Portable Instrumentation
- Avionics
- Automotive Electronics
- SMPS Post-Regulator
- Voltage Reference

APPLICATIONS

- High accuracy output voltage
- Guaranteed 100mA output
- Very low quiescent current
- Low dropout voltage
- Extremely tight load and line regulation
- Very low temperature coefficient
- Needs only 1μF for stability
- Error Flag warns of output dropout
- Logic-Controlled electronic shutdown
- Output programmable from 1.24 to 29V

PRODUCT DESCRIPTION

The PL2950-XX is a low power voltage regulator. This device excellent choice for use in battery powered application such as cordless telephone, radio control systems, and portable computers.

The PL2950-XX features very low quiescent current (75μA Typ.) and very low drop output voltage (Typ. 40mV at light load and 380mV at 100mA). This includes a tight initial tolerance of 0.5% typ., extremely good load and line regulation of 0.05% typ., and very low output temperature coefficient, making the PL2950-XX useful as a low-power voltage reference.

The error flag output feature is used as power-on reset for warn of a low output voltage, due to following batteries on input. Other feature is the logic-compatible shutdown input which enable the regulator to be switched on and off.

The PL2950-XX is offered in 3-pin TO-92 package compatible with other fixed regulator.

Absolute Maximum Ratings

Power Dissipation	Internally Limited
Lead Temperature (Soldering, 5 seconds)	260°C
Storage Temperature Range	-65°C to +150°C
Operating Junction Temperature Range	-55°C to +150°C
Input Supply Voltage	-0.3 to +30V
Feedback Input Voltage	-1.5 to +30V
Shutdown Input Voltage	-0.3 to +30V
Error Comparator Output	-0.3 to +30V

Device Selection Guide

Vout, Volts	Device
2.85*	PL2950-2.85
3.0	PL2950-3.0
3.3	PL2950-3.3
5.0	PL2950

* - other versions are also available

Vout = 2.0V to 5.0V. Please consult factory for more information

ELECTRICAL CHARACTERISTICS (at Ta =25°C, =15V; unless otherwise noted)

Parameter	Conditions(Note 2)	Min	Typ	Max	Units
Output Voltage	-25°C ≤ T _J ≤ 85°C	0.985 V _O	V _O	1.015 V _O	V
	Full Operating Temperature	0.98 V _O		1.02 V _O	
Output Voltage	100 μA ≤ I _L ≤ 100mA, T _J ≤ T _{JMAX}	0.976 V _O	V _O	1.024 V _O	
Output Voltage Temperature Coefficient	(Note 1)	-	50	150	ppm/°C
Line Regulation(Note 3)	V _O +1V ≤ V _{in} ≤ 30V	-	0.04	0.4	%
Load Regulation(Note 3)	100 μA ≤ I _L ≤ 100mA	-	0.1	0.3	%
Dropout Voltage(Note 4)	I _L =100 μA	-	50	80	mV
	I _L =100mA		380	450	
Ground Current	I _L =100 μA	-	75	120	μA
	I _L =100mA		8	12	mA
Dropout Ground Current	V _{in} =V _O -0.5V, I _L =100 μA	-	110	170	μA
Current Limit	V _{out} =0	-	160	200	mA
Thermal Regulation		-	0.05	0.2	%/W
Output Noise, 10Hz to 100KHz	C _L =1 μF	-	430	-	μVrms
	C _L =200 μF		160		
	C _L =3.3 μF		100		

Note 1: Output or reference voltage temperature coefficients defined as the worse case voltage change divided by the total temperature range.

Note 2: Unless otherwise specified all limits guaranteed for T_J=25°C, V_{in}=V_O+1V, I_L=100 μA and C_L=1 μF.

Note 3: Regulations is measured at constant junction temperature, using pulse testing with a low duty cycle.

Changes in output voltage due to heating effects are covered under the specification for thermal regulation.

Note 4: Dropout voltage is defined as the input to output differential at which the output voltage drops 100mV below its nominal value measured at 1V differential. At very low values of programmed output voltage, the minimum input supply voltage of 2V(2.3V over temperature) must be taken into account.

Block Diagram and Typical Application

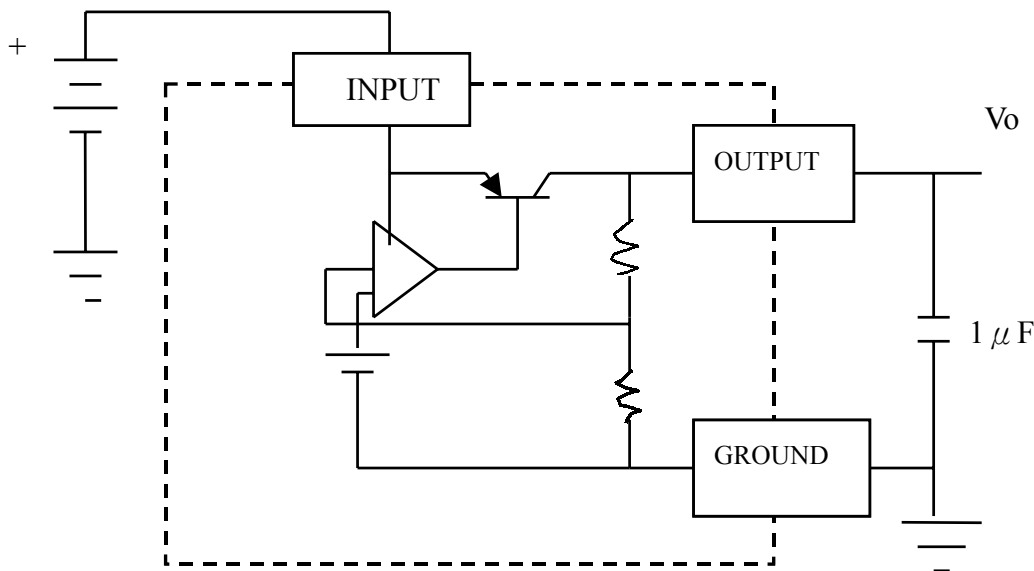

TO-92 Dimension

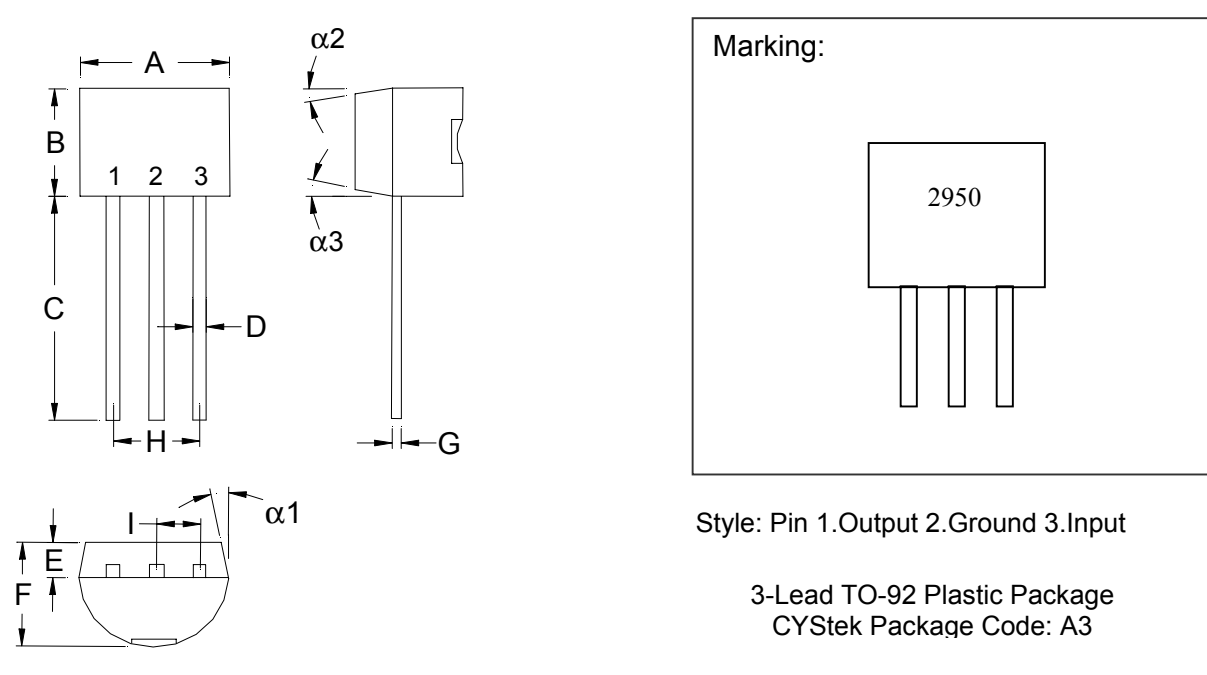

Marking:

2950

Style: Pin 1.Output 2.Ground 3.Input

3-Lead TO-92 Plastic Package
 CYStek Package Code: A3

*: Typical

DIM	Inches		Millimeters		DIM	Inches		Millimeters	
	Min.	Max.	Min.	Max.		Min.	Max.	Min.	Max.
A	0.1704	0.1902	4.33	4.83	G	0.0142	0.0220	0.36	0.56
B	0.1704	0.1902	4.33	4.83	H	-	*0.1000	-	*2.54
C	0.5000	-	12.70	-	I	-	*0.0500	-	*1.27
D	0.0142	0.0220	0.36	0.56	$\alpha 1$	-	*5°	-	*5°
E	-	*0.0500	-	*1.27	$\alpha 2$	-	*2°	-	*2°
F	0.1323	0.1480	3.36	3.76	$\alpha 3$	-	*2°	-	*2°

Notes: 1.Controlling dimension: millimeters.
 2.Maximum lead thickness includes lead finish thickness, and minimum lead thickness is the minimum thickness of base material.
 3.If there is any question with packing specification or packing method, please contact your local CYStek sales office.

Material:

- Lead: 42 Alloy ; solder plating
- Mold Compound: Epoxy resin family, flammability solid burning class: UL94V-0

Important Notice:

- All rights are reserved. Reproduction in whole or in part is prohibited without the prior written approval of CYStek.
- CYStek reserves the right to make changes to its products without notice.
- CYStek **semiconductor products are not warranted to be suitable for use in Life-Support Applications, or systems.**
- CYStek assumes no liability for any consequence of customer product design, infringement of patents, or application assistance.