

# High Temperature Accuracy Integrated Silicon Pressure Sensor On-Chip Signal Conditioned, Temperature Compensated and Calibrated

The MPXV5050VC6T1 sensor integrates on-chip, bipolar op amp circuitry and thin film resistor networks to provide a high output signal and temperature compensation. The small form factor and high reliability of on-chip integration make the Freescale Semiconductor, Inc. pressure sensor a logical and economical choice for the system designer.

The MPXV5050VC6T1 piezoresistive transducer is a state-of-the-art, monolithic, signal conditioned, silicon pressure sensor. This sensor combines advanced micromachining techniques, thin film metallization, and bipolar semiconductor processing to provide an accurate, high level analog output signal that is proportional to applied pressure.

Figure 1 shows a block diagram of the internal circuitry integrated on a pressure sensor chip.

## Features

- 2.5% Maximum Error over 0° to 85°C
- Ideally suited for Microprocessor or Microcontroller-Based Systems
- Temperature Compensated from Over -40° to +125°C
- Patented Silicon Shear Stress Strain Gauge
- Durable Thermoplastic (PPS) Surface Mount Package
- Easy-to-Use Chip Carrier Option
- Ideal for Automotive and Non-Automotive Applications

## Typical Applications

- Vacuum Pump Monitoring

ORDERING INFORMATION					
Device Type	Options	Case No.	MPX Series Order No.	Packing Options	Device Marking
Ported Element	Vacuum, Axial Port	482A	MPXV5050VC6T1	Tape & Reel	MPXV5050VC6T1

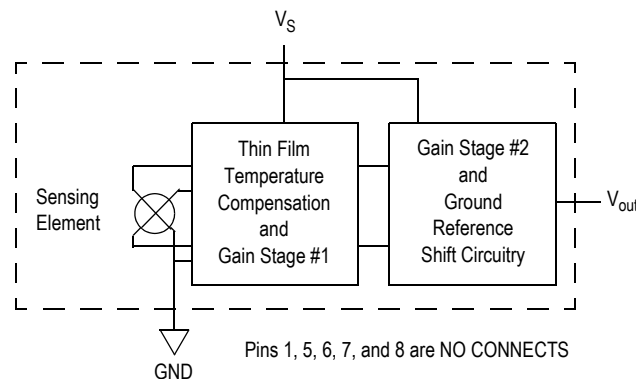
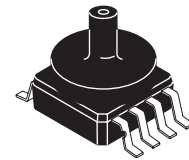


Figure 1. Fully Integrated Pressure Sensor Schematic

## MPXV5050VC6T1

**INTEGRATED  
 PRESSURE SENSOR**  
 -50 to 0 kPa (-7.25 to 0 psi)  
 0.1 to 4.6 Volts Output

## SMALL OUTLINE PACKAGE



**MPXV5050VC6T1  
 CASE 482A-01**

## PIN NUMBER<sup>(1)</sup>

1	N/C	5	N/C
2	V <sub>S</sub>	6	N/C
3	GND	7	N/C
4	V <sub>OUT</sub>	8	N/C

1. Pins 1, 5, 6, 7, and 8 are internal device connections. Do not connect to external circuitry or ground. Pin 1 is noted by the notch in the lead.

**Table 1. Maximum Ratings<sup>(1)</sup>**

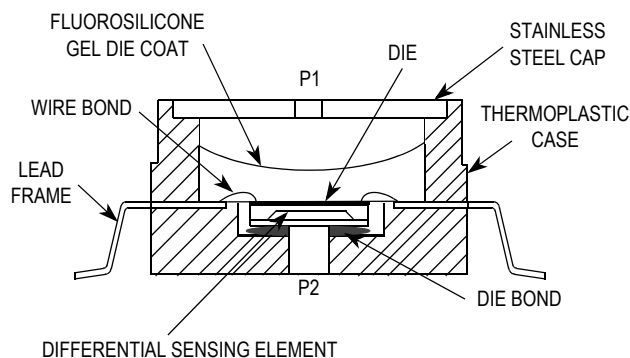
Rating	Symbol	Value	Units
Maximum Pressure (P1 > P2)	P <sub>max</sub>	200	kPa
Storage Temperature	T <sub>stg</sub>	-40° to +125°	°C
Operating Temperature	T <sub>A</sub>	-40° to +125°	°C

1. Exposure beyond the specified limits may cause permanent damage or degradation to the device.

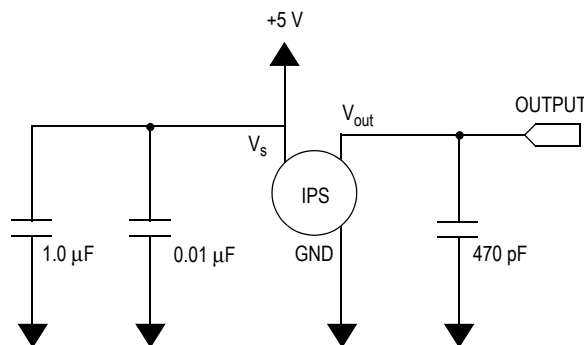
**Table 2. Operating Characteristics** (V<sub>S</sub> = 5.0 Vdc, T<sub>A</sub> = 25°C unless otherwise noted, P1 > P2.)

Characteristic	Symbol	Min	Typ	Max	Unit
Pressure Range	P <sub>OP</sub>	-50	—	0	kPa
Supply Voltage <sup>(1)</sup>	V <sub>S</sub>	4.75	5.0	5.25	Vdc
Supply Current	I <sub>o</sub>	—	7.0	10	mAdc
Full Scale Output <sup>(2)</sup> @ V <sub>S</sub> = 5.0 Volts (0 to 85°C) (P <sub>diff</sub> = 0 kPa)	V <sub>F<sub>SO</sub></sub>	4.488	4.6	4.713	Vdc
Full Scale Span <sup>(3)</sup> @ V <sub>S</sub> = 5.0 Volts (0 to 85°C)	V <sub>F<sub>SS</sub></sub>	—	4.5	—	Vdc
Accuracy <sup>(4)</sup> (0 to 85°C)	—	—	—	±2.5	%V <sub>F<sub>SS</sub></sub>
Sensitivity	V/P	—	90	—	mV/kPa
Response Time <sup>(5)</sup>	t <sub>R</sub>	—	1.0	—	ms
Warm-Up Time <sup>(6)</sup>	—	—	20	—	ms
Offset Stability <sup>(7)</sup>	—	—	±0.5	—	%V <sub>F<sub>SS</sub></sub>
Pressure Offset <sup>(8)</sup> (0 to 85°C)	V <sub>off</sub>	0	0.1	0.213	Vdc

- Device is ratiometric within this specified excitation range.
- Full Scale Output (V<sub>F<sub>SO</sub></sub>) is defined as the output voltage at the maximum or full rated pressure.
- Full Scale Span (V<sub>F<sub>SS</sub></sub>) is defined as the algebraic difference between the output voltage at full rated pressure and the output voltage at the minimum rated pressure.
- Accuracy is the deviation in actual output from nominal output over the entire pressure range and temperature range as a percent of span at 25°C due to all sources of errors, including the following:
  - Linearity: Output deviation from a straight line relationship with pressure over the specified pressure range.
  - Temperature Hysteresis: Output deviation at any temperature within the operating temperature range, after the temperature is cycled to and from the minimum or maximum operating temperature points, with zero differential pressure applied.
  - Pressure Hysteresis: Output deviation at any pressure within the specified range, when this pressure is cycled to and from minimum or maximum rated pressure at 25°C.
  - TcSpan: Output deviation over the temperature range of 0° to 85°C, relative to 25°C.
  - TcOffset: Output deviation with minimum pressure applied, over the temperature range of 0° to 85°C, relative to 25°C.
- Response Time is defined as the time for the incremental change in the output to go from 10% to 90% of its final value when subjected to a specified step change in pressure.
- Warm-up Time is defined as the time required for the product to meet the specified output voltage after the pressure has been stabilized.
- Offset Stability is the product's output deviation when subjected to 1000 hours of Pulsed Pressure, Temperature Cycling with Bias Test.
- Offset (V<sub>off</sub>) is defined as the output voltage at the minimum rated pressure.

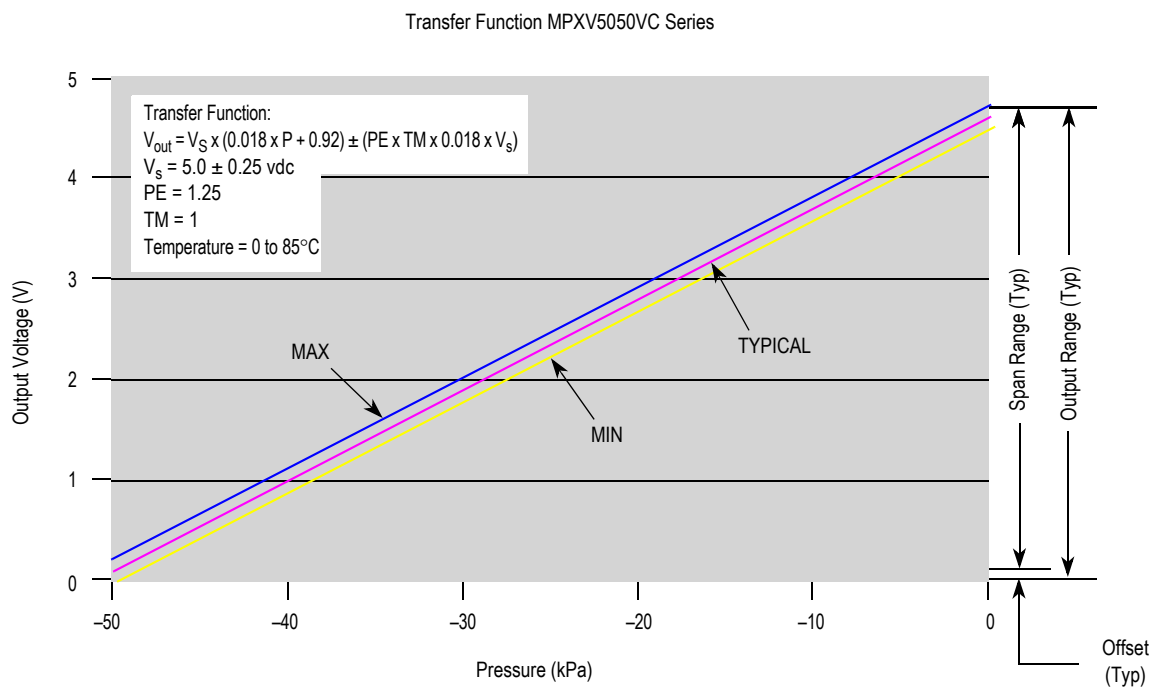


**Figure 2. Cross-Sectional Diagram (not to scale)**



**Figure 3. Typical Application Circuit (Output Source Current Operation)**

### TRANSFER FUNCTION MPXV5050VC6T1



**Figure 4. Output versus Absolute Pressure**

Figure 4 shows the sensor output signal relative to pressure input. Typical minimum and maximum output curves are shown for operation over 0 to 85°C temperature range. The output will saturate outside of the rated pressure range.

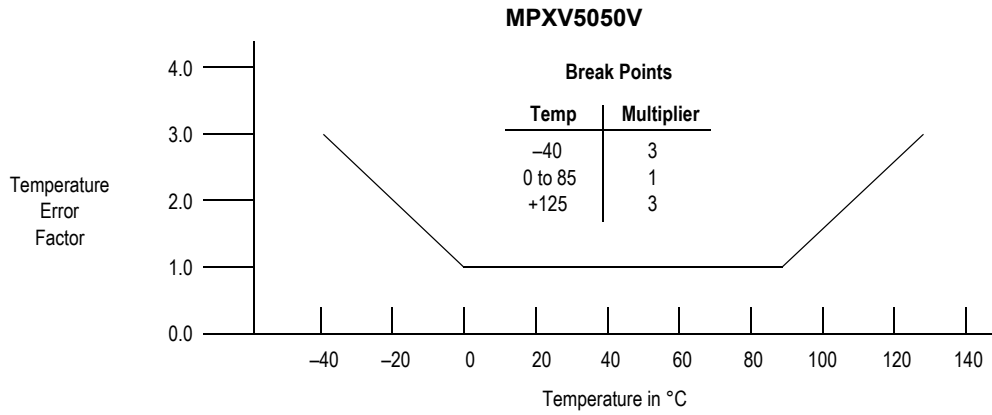
A fluorosilicone gel isolates the die surface and wire bonds from the environment, while allowing the pressure signal to

be transmitted to the silicon diaphragm. The MPXV5050VC6T1 pressure sensor operating characteristics, internal reliability and qualification tests are based on use of dry air as the pressure media. Media other than dry air may have adverse effects on sensor performance and long-term reliability. Contact the factory for information regarding media compatibility in your application.

## Transfer Function (MPXV5050VC6T1)

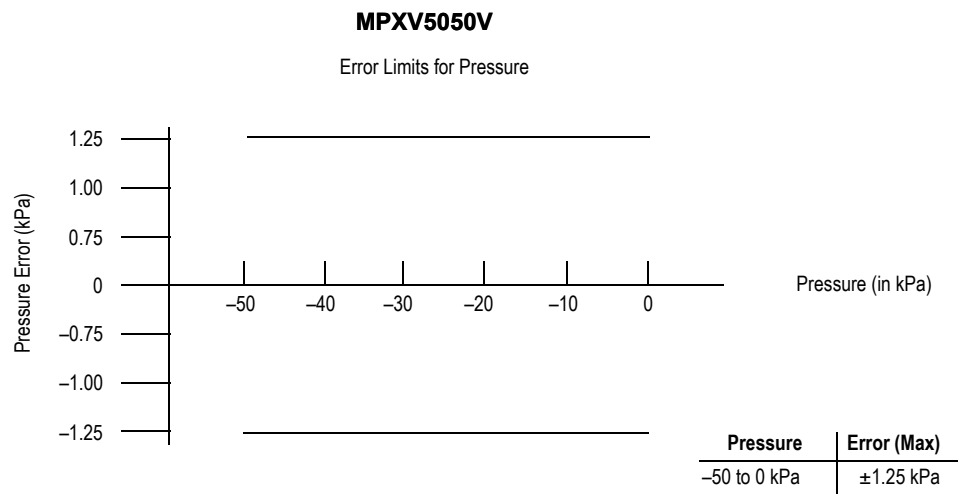
**Nominal Transfer Value:**  $V_{out} = V_S \times (0.018 \times P + 0.92)$   
 $\pm (\text{Pressure Error} \times \text{Temp Multi} \times 0.018 \times V_S)$   
 $V_S = 5.0 \pm 0.25 \text{ V}$

## Temperature Error Band



NOTE: The Temperature Multiplier is a linear response from 0°C to -40°C and from 85°C to 125°C.

## Pressure Error Band



## MINIMUM RECOMMENDED FOOTPRINT FOR SMALL OUTLINE PACKAGE

Surface mount board layout is a critical portion of the total design. The footprint for the semiconductor package must be the correct size to ensure proper solder connection interface between the board and the package. With the correct pad geometry, the packages will self-align when subjected to a

solder reflow process. It is always recommended to fabricate boards with a solder mask layer to avoid bridging and/or shorting between solder pads, especially on tight tolerances and/or tight layouts.

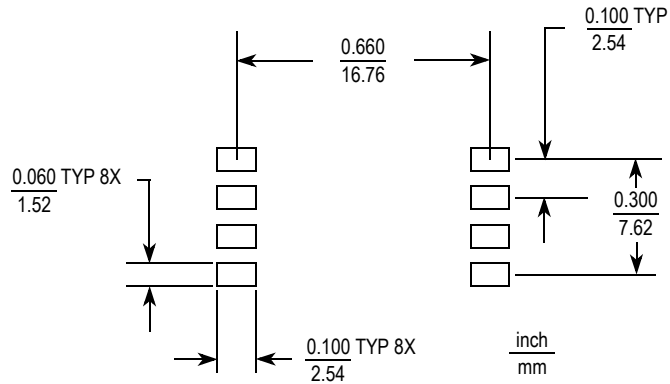
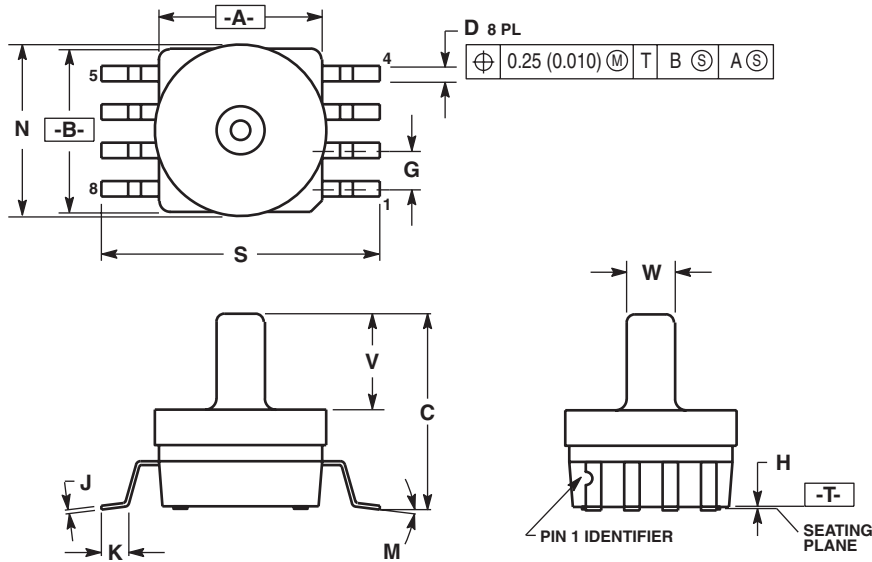


Figure 5. SOP Footprint (Case 482A)

## PACKAGE DIMENSIONS



- NOTES:
1. DIMENSIONING AND TOLERANCING PER ANSI Y14.5M, 1982.
  2. CONTROLLING DIMENSION: INCH.
  3. DIMENSION A AND B DO NOT INCLUDE MOLD PROTRUSION.
  4. MAXIMUM MOLD PROTRUSION 0.15 (0.006).
  5. ALL VERTICAL SURFACES 5° TYPICAL DRAFT.

DIM	INCHES		MILLIMETERS	
	MIN	MAX	MIN	MAX
A	0.415	0.425	10.54	10.79
B	0.415	0.425	10.54	10.79
C	0.500	0.520	12.70	13.21
D	0.038	0.042	0.96	1.07
G	0.100 BSC		2.54 BSC	
H	0.002	0.010	0.05	0.25
J	0.009	0.011	0.23	0.28
K	0.061	0.071	1.55	1.80
M	0"	7"	0"	7"
N	0.444	0.448	11.28	11.38
S	0.709	0.725	18.01	18.41
V	0.245	0.255	6.22	6.48
W	0.115	0.125	2.92	3.17

**CASE 482A-01  
 ISSUE A  
 SMALL OUTLINE PACKAGE**



## NOTES

## **How to Reach Us:**

### **Home Page:**

www.freescale.com

### **E-mail:**

support@freescale.com

### **USA/Europe or Locations Not Listed:**

Freescale Semiconductor  
Technical Information Center, CH370  
1300 N. Alma School Road  
Chandler, Arizona 85224  
+1-800-521-6274 or +1-480-768-2130  
support@freescale.com

### **Europe, Middle East, and Africa:**

Freescale Halbleiter Deutschland GmbH  
Technical Information Center  
Schatzbogen 7  
81829 Muenchen, Germany  
+44 1296 380 456 (English)  
+46 8 52200080 (English)  
+49 89 92103 559 (German)  
+33 1 69 35 48 48 (French)  
support@freescale.com

### **Japan:**

Freescale Semiconductor Japan Ltd.  
Headquarters  
ARCO Tower 15F  
1-8-1, Shimo-Meguro, Meguro-ku,  
Tokyo 153-0064  
Japan  
0120 191014 or +81 3 5437 9125  
support.japan@freescale.com

### **Asia/Pacific:**

Freescale Semiconductor Hong Kong Ltd.  
Technical Information Center  
2 Dai King Street  
Tai Po Industrial Estate  
Tai Po, N.T., Hong Kong  
+800 2666 8080  
support.asia@freescale.com

### **For Literature Requests Only:**

Freescale Semiconductor Literature Distribution Center  
P.O. Box 5405  
Denver, Colorado 80217  
1-800-441-2447 or 303-675-2140  
Fax: 303-675-2150  
LDCForFreescaleSemiconductor@hibbertgroup.com

Information in this document is provided solely to enable system and software implementers to use Freescale Semiconductor products. There are no express or implied copyright licenses granted hereunder to design or fabricate any integrated circuits or integrated circuits based on the information in this document.

Freescale Semiconductor reserves the right to make changes without further notice to any products herein. Freescale Semiconductor makes no warranty, representation or guarantee regarding the suitability of its products for any particular purpose, nor does Freescale Semiconductor assume any liability arising out of the application or use of any product or circuit, and specifically disclaims any and all liability, including without limitation consequential or incidental damages. "Typical" parameters that may be provided in Freescale Semiconductor data sheets and/or specifications can and do vary in different applications and actual performance may vary over time. All operating parameters, including "Typicals", must be validated for each customer application by customer's technical experts. Freescale Semiconductor does not convey any license under its patent rights nor the rights of others. Freescale Semiconductor products are not designed, intended, or authorized for use as components in systems intended for surgical implant into the body, or other applications intended to support or sustain life, or for any other application in which the failure of the Freescale Semiconductor product could create a situation where personal injury or death may occur. Should Buyer purchase or use Freescale Semiconductor products for any such unintended or unauthorized application, Buyer shall indemnify and hold Freescale Semiconductor and its officers, employees, subsidiaries, affiliates, and distributors harmless against all claims, costs, damages, and expenses, and reasonable attorney fees arising out of, directly or indirectly, any claim of personal injury or death associated with such unintended or unauthorized use, even if such claim alleges that Freescale Semiconductor was negligent regarding the design or manufacture of the part.

Freescale™ and the Freescale logo are trademarks of Freescale Semiconductor, Inc. All other product or service names are the property of their respective owners.

© Freescale Semiconductor, Inc. 2005. All rights reserved.

