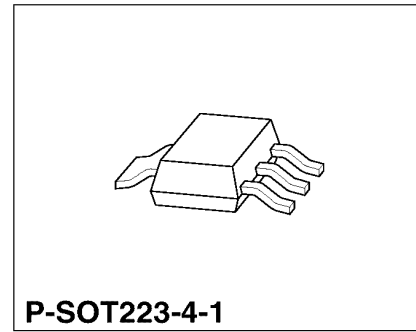

5V/100mA Low-Drop Fixed-Voltage Regulator (analog TLE4264G, Siemens)

ILE4264G (analog TLE4264G, Siemens) – is a single-chip 5V/100mA low-drop fixed-voltage regulator implemented in a plastic P-SOT223-4-1 package as per Siemens specification.

The circuit of 5V/100mA low-drop fixed-voltage regulator regulates fixed voltage of 5V with low-drop voltage less than 0.5V at load current of 100mA. Applied in power sources of electronic equipment including automotive electronics. The circuit is protected against overload of either positive or negative polarity, internal limiting of maximum load current with temperature reset of output voltage

**Features:**

- 5V output voltage tolerance $\pm 2\%$
- Low-drop voltage
- Very low current consumption
- Built-in overtemperature protection
- Protection against pins reverse polarity
- Junction temperature range from - 40 up to +125°C.

Pin Definition

Pin	Symbol	Catalogue description	Function
1	U_I	Input voltage	Input
2, 4	GND	Ground	Ground
3	U_Q	5-V output voltage	Output

ILE4264

ABSOLUTE MAXIMUM RATINGS

Parameter	Unit	Operating values		Absolute maximum values	
		min	max	min	max
Junction temperature, T_J	$^{\circ}\text{C}$	-40	125	-40	150
Storage temperature, T_{stg}	$^{\circ}\text{C}$	-	-	-50	150
Input voltage, U_I	V	5,5	45	-42	42
Input current, I_I	A	-	Limited internally	-	Not limited internally
Current on "ground" (pin 2), I_{GND}	mA	15	-	50	-
Output current (pin 3)	A	-	Limited internally	-	Not limited internally
Resistance junction-case, R_{thJC}	$^{\circ}\text{C/Wt}$	-	25*	-	25*
Resistance junction-air, R_{thJA}	$^{\circ}\text{C/Wt}$	-	125*	-	125*
<p>Notes:</p> <p>1 * - R_{thja} - thermal resistance "junction-air" (for IC without additional external heat sink), $^{\circ}\text{C/Wt}$. The same parameter in analog IC is $R_{\text{thja}} = 125^{\circ}\text{C/B}\tau$ (by "Siemens" information data). Thermal resistance "junction-air" of this circuit is determined in the course of research & development work.</p> <p>For the circuit with additional external heat sink:</p> $R_{\text{thja}} = R_{\text{thjc}} + R_{\text{thca}}, \quad (1)$ <p>Where R_{thjc} – IC thermal resistance "junction-case", $^{\circ}\text{C/Wt}$. The same parameter in analog IC is $R_{\text{thjc}} = 25^{\circ}\text{C/Wt}$ ((by "Siemens" information data). Thermal resistance "case-air" R_{thca} in the designed IC is determined by heat sink structure and specified by IC consumer.</p> <p>Heat sink, switching "on" mode (power consumed) and ambient temperature should ensure junction temperature not more than $T_J \leq +125^{\circ}\text{C}$.</p> <p>2 Absolute maximum power P_{tot}, Wt, dissipated by the IC at the ambient temperature T_A, is determined as:</p> $P_{\text{tot}} = (125 - T_A) / R_{\text{thja}}, \quad (2)$ <p>where 125 – absolute maximum junction operation temperature, $^{\circ}\text{C}$</p>					

ILE4264

Typical electrical parameters ($V_I=13,5\text{ V}$, $T_J=25^\circ\text{C}$, unless specified otherwise)

Parameter	Symbol	Test conditions	Typ. Value
Supply voltage suppression, dB	SVR	$f = 100\text{ Hz}$, $U_R = 0.5U_{PP}$,	54

Electrical parameters

($V_I=13.5\text{V}$, $-40\text{ }^\circ\text{C} \leq T_J \leq 125\text{ }^\circ\text{C}$, unless specified otherwise)

Parameter	Symbol	Test conditions	Standard	
			min	max
Output voltage, V	U_Q	$6\text{V} \leq U_I \leq 28\text{V}$ $5\text{mA} \leq I_Q \leq 100\text{mA}$	4.9	5.1
Output current, mA	I_Q		120	
Consumption current, mA, $I_q = I_I - I_Q$	I_q	$I_Q=1\text{ mA}$ $I_Q=100\text{ mA}$		0,4 15
Drop voltage, V	U_{Dr}	$I_Q=100\text{ mA}$		0.5
Output voltage versus load current, mV	$\Delta U_{Q(I)}$	$5\text{mA} \leq I_O \leq 100\text{mA}$ $V_I = 6\text{ V}$		40
Output voltage versus input voltage, mV	$\Delta U_{Q(U)}$	$6\text{V} \leq U_I \leq 28\text{V}$ $I_Q=5\text{mA}$		30

Notes:

1 The electrical parameters are measured when input capacitor $C_I = 1000\text{ mkF}$ and output capacitor $C_Q = 10\text{ mkF}$ are connected. Application circuit is in attachment A. IC block diagram is in attachment B.

2 The parameters indicated in table 1 are guaranteed at constant junction temperature T_J . The parameters should be measured using pulse equipment.

ILE4264

TYPICAL APPLICATION CIRCUIT OF ILE4264G

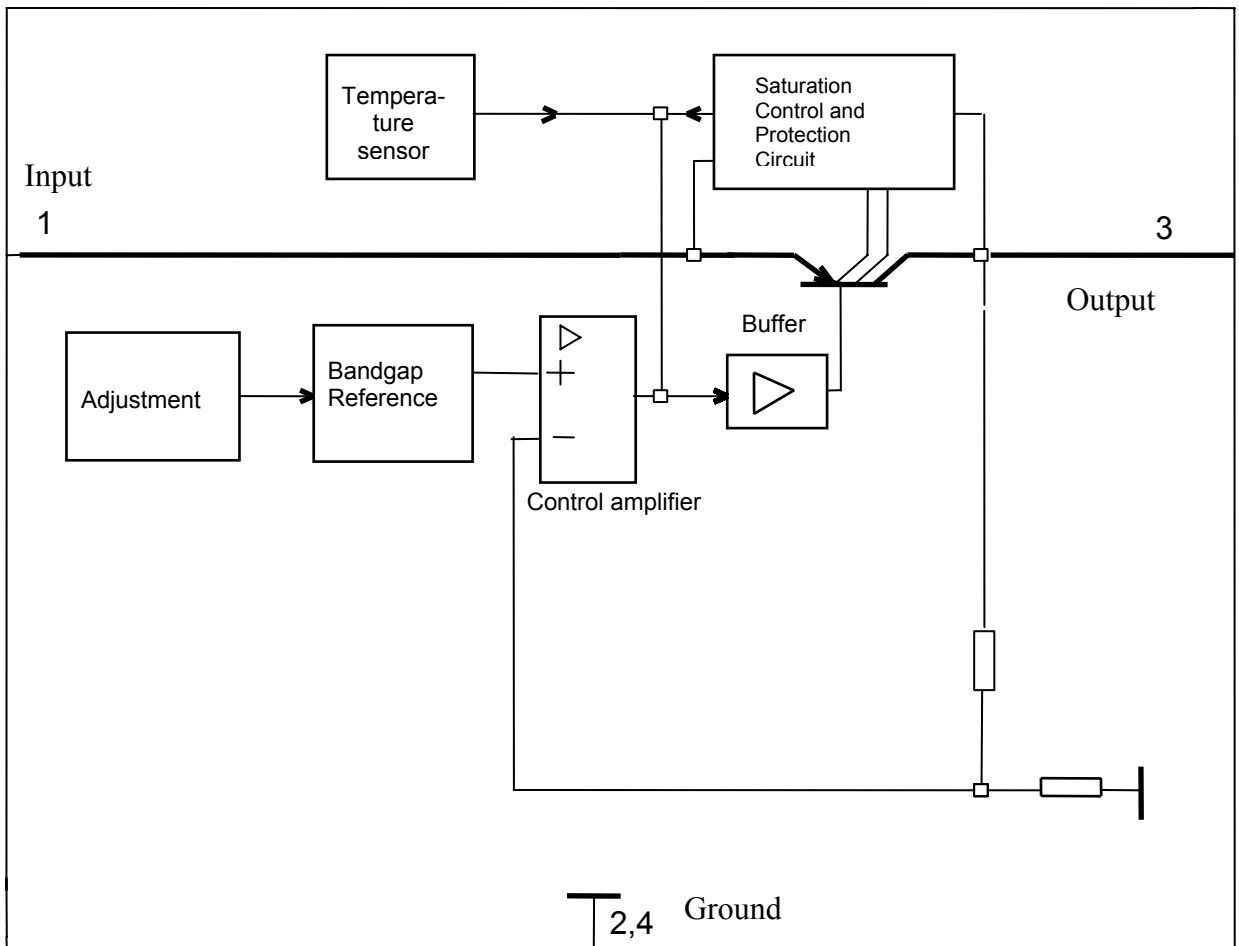
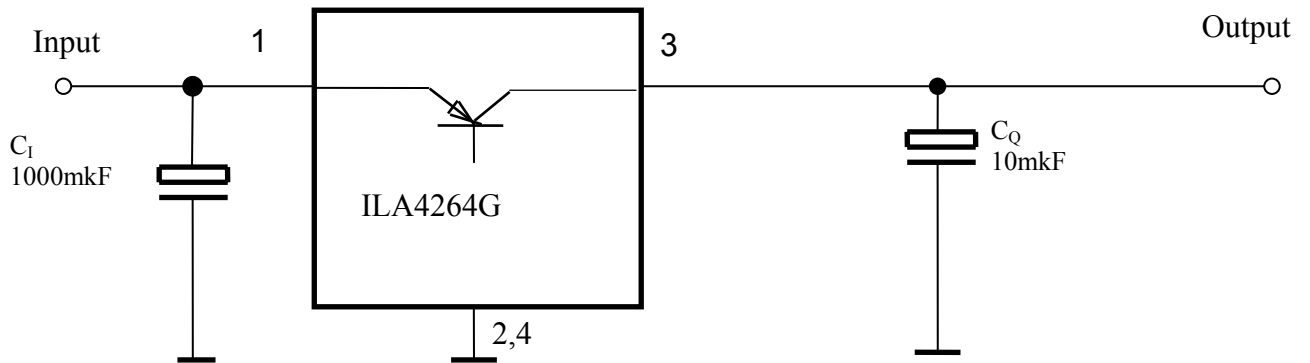

Block diagram