

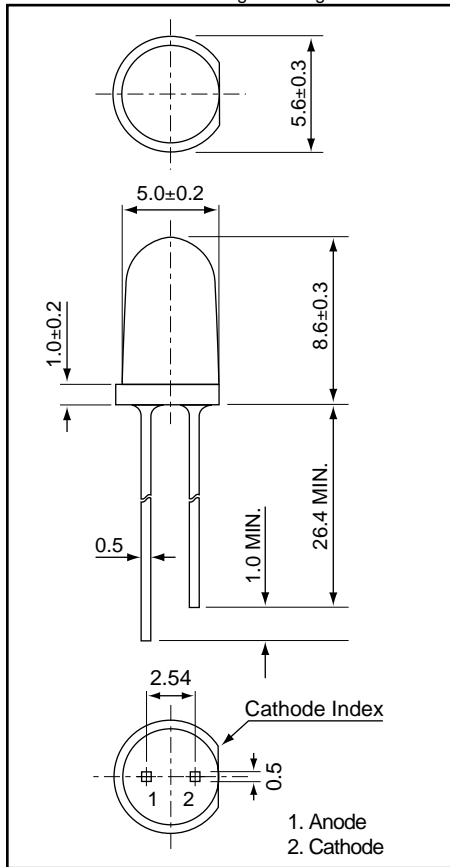

Weight: 0.31 g Unit: mm



# AND180CRP

## GaAIAs Red Light Emission

### T-1 3/4 Package (5 mm)

#### Features

- Peak wavelength ( $\lambda_p = 660$  nm) high bright emission
- All plastic mold type, clear colorless lens
- Low drive current: 20 mA for outdoor applications  
0.5 mA for indoor applications
- Excellent On-Off contrast ratio
- Fast response time, capable of pulse operation
- Suitable for Outdoor Message Signboards

#### Maximum Ratings ( $T_a = 25^\circ\text{C}$ )

Characteristics	Symbol	Rating	Unit
Forward Current	$I_F$	40	mA
Reverse Voltage	$V_R$	5	V
Power Dissipation	$P_D$	125	mW
Operating Temperature Range	$T_{Opr}$	-40 to 85	$^\circ\text{C}$
Storage Temperature Range	$T_{Stg}$	-40 to 100	$^\circ\text{C}$

#### Electro-Optical Characteristics ( $T_a = 25^\circ\text{C}$ )

Characteristics	Symbol	Test Condition	Minimum	Typical	Maximum	Unit
Forward Voltage	$V_F$	$I_F = 20$ mA	–	1.7	2.4	V
Reverse Current	$I_R$	$V_R = 4$ V	–	–	10	$\mu\text{A}$
Luminous Intensity	$I_V$	$I_F = 20$ mA	2,500	3,600	–	mcd
Peak Emission Wavelength	$\lambda_p$	$I_F = 20$ mA	–	660	–	nm
Spectral Line Half Width	$\Delta\lambda$	$I_F = 20$ mA	–	20	–	nm
Dominant Wavelength	$\lambda_d$	$I_F = 20$ mA	–	643	–	nm
Full Viewing Angle	$\theta$	$I_V = 1/2$ Peak	–	10	–	degree

#### Precaution

Please be careful of the following:

1. Soldering temperature: 260 $^\circ\text{C}$  max  
Soldering time: 5 sec. max  
Soldering portion of lead: up to 1.6 mm from the body of the device
2. The lead can be formed up to 5 mm from the body of the device without forming stress.  
Soldering should be performed after the lead forming.

