

TOSHIBA Bipolar Linear Integrated Circuit Silicon Monolithic

TA8220HQ

30W BTL × 2ch Audio Power Amplifier

The thermal resistance θ_{j-T} of TA8220HQ package designed for low thermal resistance, has high efficiency of heat radiation. The temperature rise of chip can be reduced, and the influence from the degradation of the features due to the temperature rise at the high output can also be reduced.

This stereo audio power IC, designed for car audio use, has two built-in channels to reduce the characteristic difference between L and R channels. It also contains output short detection circuit, output clip detection and various kind of protection.

Features

- Low thermal resistance: $\theta_{j-T} = 1.5^{\circ}\text{C} / \text{W}$ (infinite heat sink)
- High power: $\text{POUT (1)} = 30\text{W (typ.)} / \text{channel}$
($V_{CC} = 14.4\text{V}$, $f = 1\text{kHz}$, $\text{THD} = 10\%$, $R_L = 2\Omega$)
: $\text{POUT (2)} = 26\text{W (typ.)} / \text{channel}$
($V_{CC} = 13.2\text{V}$, $f = 1\text{kHz}$, $\text{THD} = 10\%$, $R_L = 2\Omega$)
: $\text{POUT (3)} = 19\text{W (typ.)} / \text{channel}$
($V_{CC} = 13.2\text{V}$, $f = 1\text{kHz}$, $\text{THD} = 10\%$, $R_L = 4\Omega$)
- Low distortion ratio: $\text{THD} = 0.04\%$ (typ.)
($V_{CC} = 13.2\text{V}$, $f = 1\text{kHz}$, $\text{POUT} = 1\text{W}$, $R_L = 4\Omega$, $G_V = 50\text{dB}$)
- Low noise: $V_{\text{NO}} = 0.30\text{mV}_{\text{RMS}}$ (typ.)
($V_{CC} = 13.2\text{V}$, $R_L = 4\Omega$, $G_V = 50\text{dB}$, $R_g = 0\Omega$, $\text{BW} = 20\text{Hz} \sim 20\text{kHz}$)
- Built-in stand-by function (with (4)pin set at low, power is turned off.): $\text{ISB} = 1\mu\text{A}$ (typ.)
- Built-in output short detection circuit ((9)pin: Open collector)
- Built-in output clip detection circuit ((1)pin: Open collector)
- Built-in various protection circuits
Protection circuits: Thermal shut down, Over voltage, Out→VCC short, Out→GND short and Out-Out short.
- Operating supply voltage: $V_{CC} = 9 \sim 18\text{V}$

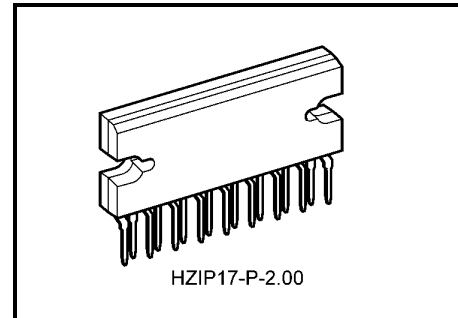

Weight: 9.8g (typ.)

Block Diagram

TA8220HQ (G_v = 50dB)

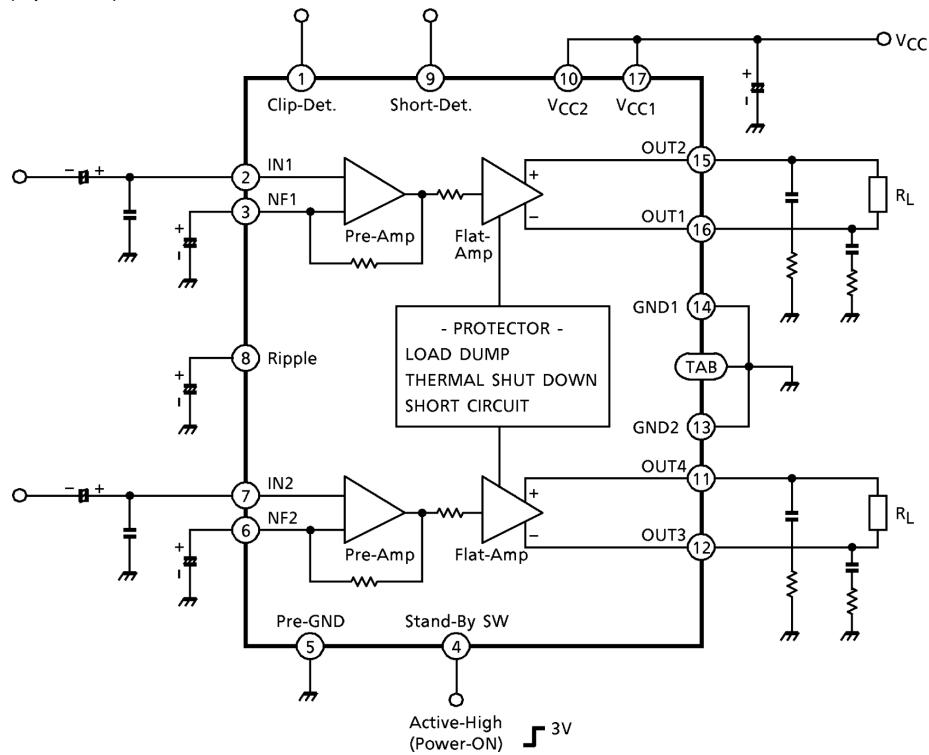

Caution And Application Method (description is made only on the single channel.)

1. Voltage gain adjustment

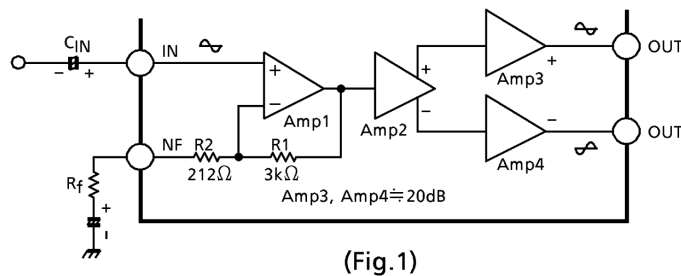

- Amp1 : Pre-Amp
- Amp2 : Phase Amp
- Amp3 : POWER Amp (Flat-Amp)
- Amp4 : POWER Amp (Flat-Amp)

This IC has the amplifier constructions as shown Fig.1. The pre-amp (amp1) is provided to the primary stage, and the input voltage is amplified by the flat amps, amp3 and amp4 of each channel through the phase amp (amp2).

Since the input offset is prevented by pre-amp when VCC is set to on, this circuit can remarkably reduce the pop noise.

The total closed loop gain G_V of this IC can be obtained by expression below when the closed loop voltage gain of amp1 is G_{V1} .

$$G_{V1} = 20 \log \frac{R_1 + (R_f + R_2)}{R_f + R_2} \text{ (dB)} \dots\dots\dots (1)$$

The closed loop voltage gain of power amp, amp3 and amp4 is fixed at $G_{V3} \doteq G_{V4} = 20\text{dB}$.
Therefore, the total closed circuit voltage gain G_V is obtained through BTL connection by the expression below.

$$G_V = G_{V1} + G_{V3} + 6 \text{ (dB)} \dots\dots\dots (2)$$

For example, when $R_f = 0\Omega$, G_V is obtained by the expressions (1) and (2) as shown below.

$$G_V \doteq 24 + 20 + 6 = 50\text{dB}$$

The voltage gain is reduced when R_f is increased. (Fig.2)

With the voltage gain reduced, since (1) the oscillation stability is reduced, and (2) the pop noise changes when V_{CC} is set to on, refer to the items 3 and 4.

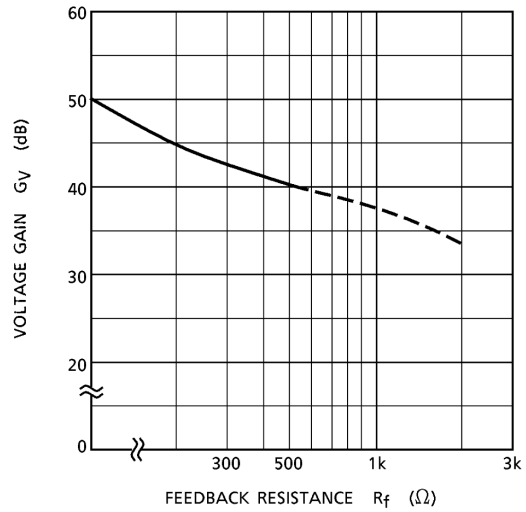

(Fig.2)

2. Stand-by SW function

By means of controlling (4)pin (stand-by terminal) to high and low, the power supply can be set to on and off. The threshold voltage of (4)pin is set at 2.1V ($3V_{BE}$), and the power supply current is about 1 μ A (typ.) at the stand-by state.

Control voltage of (4)pin: $V_{(SB)}$

Stand-By	Power	$V_{(SB)}$ (V)
On	Off	0~2
Off	On	$3 \sim V_{CC}$

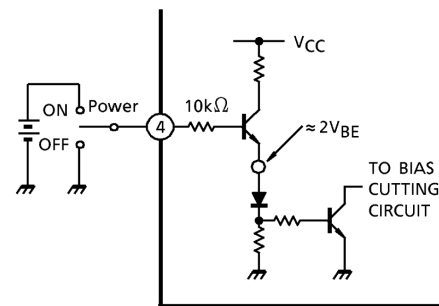

(Fig.3) With ④ pin set to high, power is turned ON.

<Adjustage of stand-by SW>

- (1) Since V_{CC} can directly be controlled to on / off by the microcomputer, the switching relay can be omitted.
- (2) Since the control current is microscopic, the switching relay of small current capacity is satisfactory for switching.

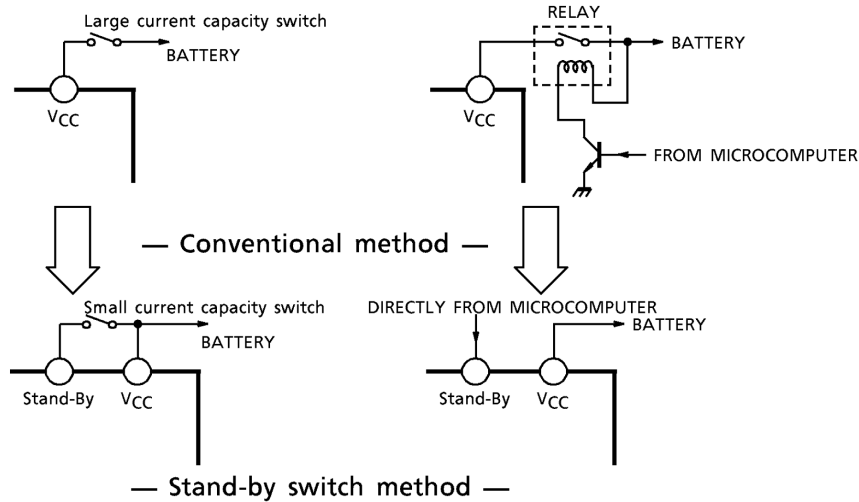

3. Preventive measure against oscillation

For preventing the oscillation, it is advisable to use C4, the condenser of polyester film having small characteristic fluctuation of the temperature and the frequency.
 The condenser (C6) between input and GND is effective for preventing oscillation which is generated with a feedback signal from a output stage.
 The resistance R to be series applied to C4 is effective for phase correction of high frequency, and improves the oscillation allowance.

- (1) Voltage gain to be used (GV setting)
- (2) Capacity value of condenser
- (3) Kind of condenser
- (4) Layout of printed board

In case of its use with the voltage gain GV reduced or with the feedback amount increased, care must be taken because the phase-inversion is caused by the high frequency resulting in making the oscillation liable generated.

4. Adjustment of output offset (when the power supply turn on)

As this IC is constructed with DC circuit on the pre-amp stage, it is necessary to lower a input offset or output offset by agreement with the each leading edge time constant of the input voltage in the pre-amp stage and NF terminal voltage.

Concretely, monitor the output DC voltage and vary the capacity value in input condenser and NF condenser (see Fig.4)

(Reference) In case of setting the condition (GV = 40dB) with $R_f = 470\Omega$

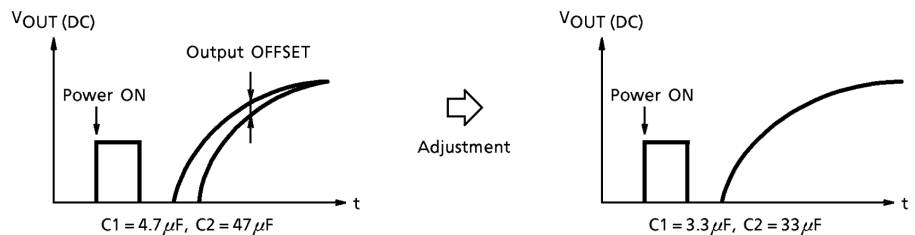

(Fig.4)

5. Output clip detection function (pin(1))

The output clip detection terminal of pin(1) has the open collector output structure on clip as shown in Fig.5. In case that the output waveform is clipping, the clip detection circuit is operated and NPN Tr. is turned on. It is possible to improve the tone quality with the current of flowing into pin(1) and with controlling the volume, tone control circuit through L.P.F smoothing circuit as shown in Fig.5.

In case of being unused this function, use this IC as open connection on pin(1).

(Application)

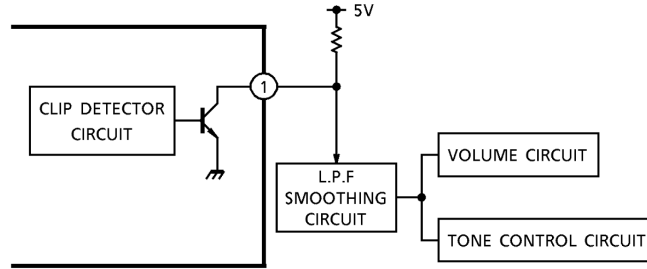

(Fig.5) ① pin : Open collector output (Active low)

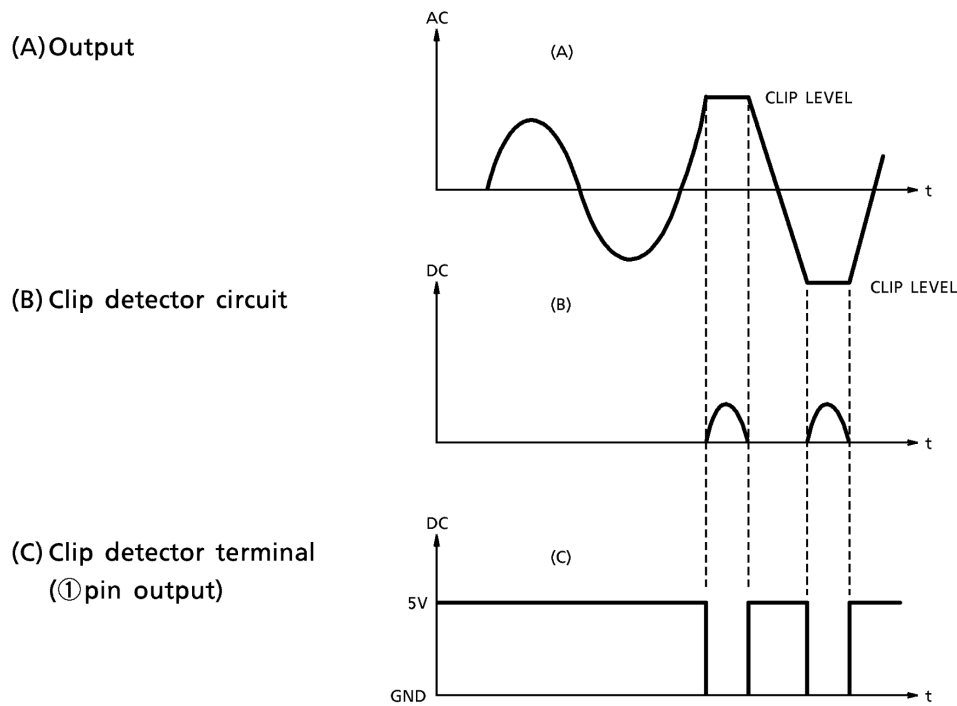

6. Output to VCC, output to GND detection function (pin(9))

The output short detection terminal of pin(9) has open collector output structure on chip as shown in Fig.6. In unusual case that output terminal of power amp. is condition of output to VCC or output to GND short, it is possible to protect all the system of apparatus as well as power IC protection. In case of being unused this function, use this IC as open-connection on pin(9).

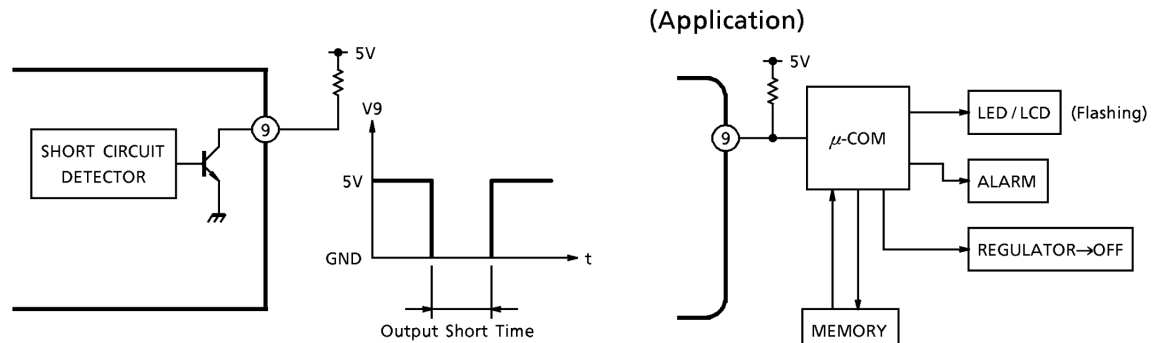

Ⓣpin : Open Collector Output (Active Low)

(Fig.6)

7. External part list and description

Sym- bol	Recommended Value	Feature	Influence		Remarks
			Smaller Than Recommended Value	Larger Than Recommended Value	
C1	4.7μF	DC blocking	Related to pop noise at V _{CC} →on.		Related to gain. Refer to item 4.
C2	47μF	Feedback condenser	Related to pop noise at V _{CC} →on. Determination of low cut-off frequency $C2 = \frac{1}{2\pi \cdot f_L \cdot R_f}$		
C3	220μF	Ripple reduction	Time constant is small at V _{CC} →on or off.	Time constant is large at V _{CC} →on or off.	
C4	0.12μF	Oscillation prevention	Made liable to oscillate.	Oscillation allowance	Refer to item 3.
C5	1000μF	Ripple filter	For filtering power supply hum and ripple. Large at using AC rectified power supply. Small at using DC power supply.		
C6	1000pF	Oscillation prevention	Oscillation allowance improved. Noise reduction		Refer to item 3.

Maximum Ratings (Ta = 25°C)

Characteristic	Symbol	Rating	Unit
Peak input voltage (0.2s)	V _{CC} (surge)	50	V
DC supply voltage	V _{CC} (DC)	25	V
Operating supply voltage	V _{CC} (opr)	18	V
Output current (peak)	I _O (peak)	9	A
Power dissipation	P _D	50	W
Operating temperature	T _{opr}	-30~85	°C
Storage temperature	T _{stg}	-55~150	°C

Electrical Characteristics

(unless otherwise specified, V_{CC} = 13.2V, R_L = 4Ω, f = 1kHz, Ta = 25°C)

Characteristic	Symbol	Test Circuit	Test Condition	Min.	Typ.	Max.	Unit
Quiescent supply current	I _{CCQ}	—	V _{IN} = 0	—	120	250	mA
Output power	P _{OUT} (1)	—	V _{CC} = 14.4V, R _L = 2Ω, THD = 10%	—	30	—	W
	P _{OUT} (2)	—	R _L = 2Ω, THD = 10%	17	26	—	
	P _{OUT} (3)	—	THD = 10%	16	19	—	
Total harmonic distortion	THD	—	P _{OUT} = 1W	—	0.04	0.4	%
Voltage gain	G _V	—		48	50	52	dB
Voltage gain ratio	ΔG _V	—		-1.0	0	1.0	dB
Output noise voltage	V _{NO}	—	R _g = 0Ω, BW = 20Hz~20kHz	—	0.3	0.7	mV _{rms}
Ripple rejection ratio	R.R.	—	f _{ripple} = 100Hz, R _g = 600Ω	40	54	—	dB
Input resistance	R _{IN}	—		—	30	—	kΩ
Output offset voltage	V _{offset}	—	V _{IN} = 0	-100	0	100	mV
Current at stand-by state	I _{SB}	—		—	1	10	μA
Cross talk	C.T.	—	R _g = 600Ω, V _{OUT} = 0.775V _{rms} (0dBm)	—	60	—	dB
(4)pin control voltage	V _{SB}	—	Stand-by→off (power→on)	2.5	—	V _{CC}	V
(1)pin (clip DET) saturation voltage	V _{sat} (1)	—	I _C = 1mA	—	100	—	mV
(9)pin (short DET) saturation voltage	V _{sat} (9)	—	I _C = 1mA	—	100	—	mV

V_{sat} (1), V_{sat} (9) Test Circuit

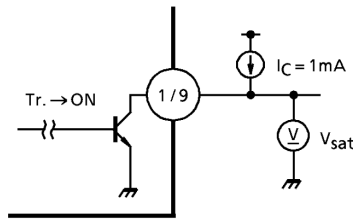

Test Circuit

TA8220HQ (G_v = 50dB)

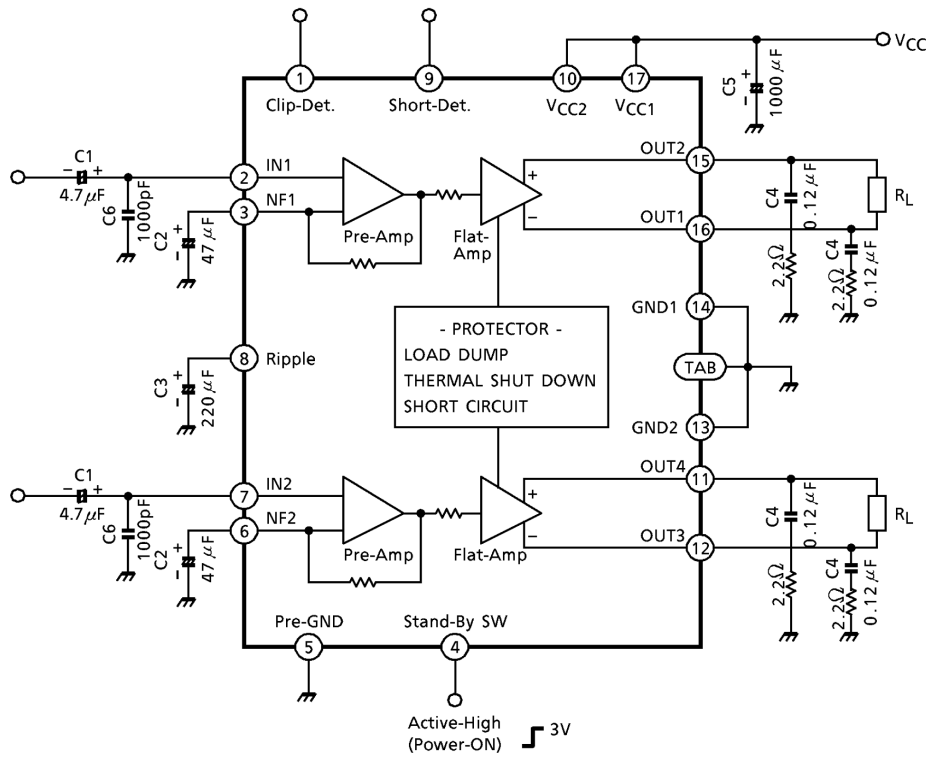

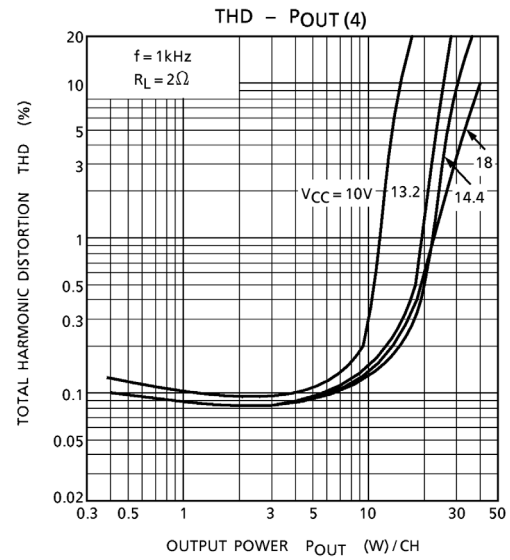
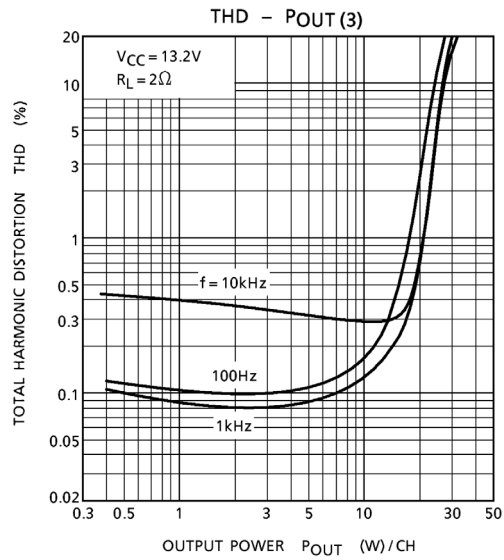
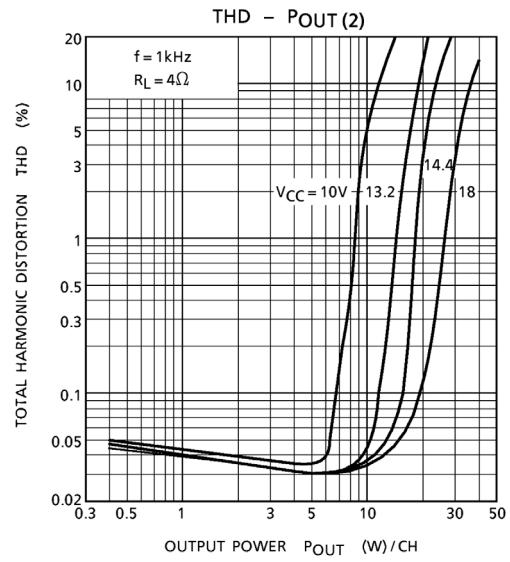
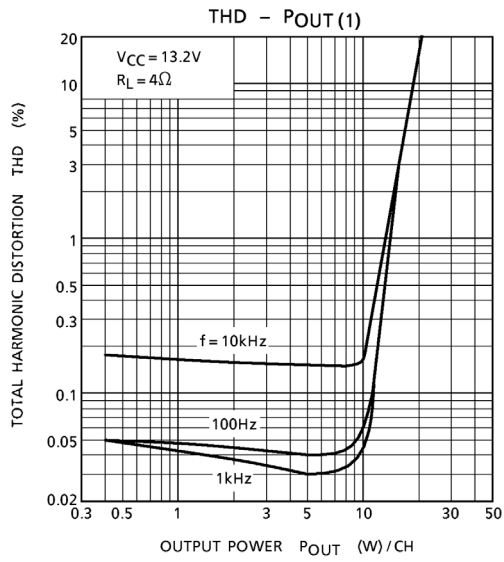

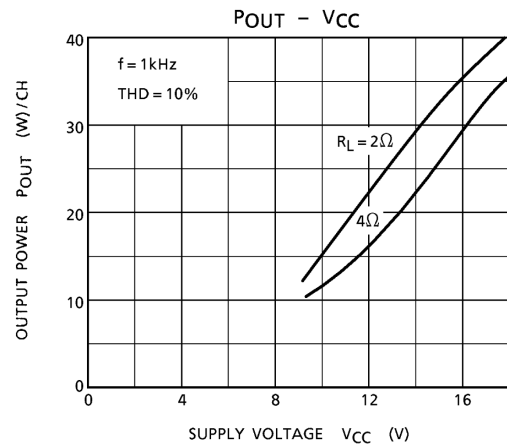
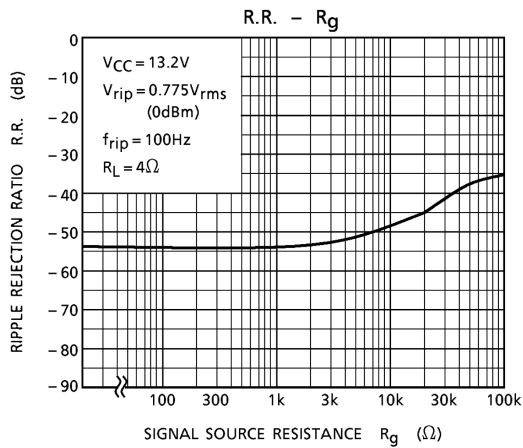
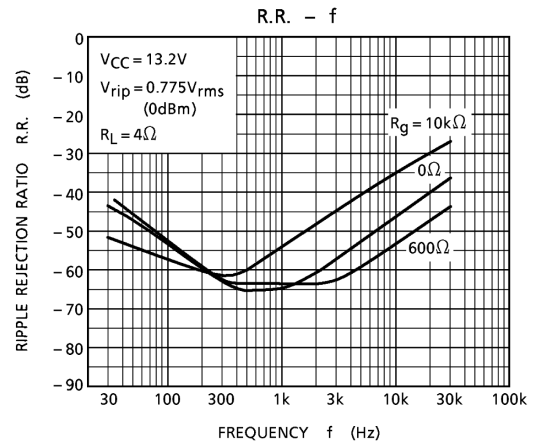
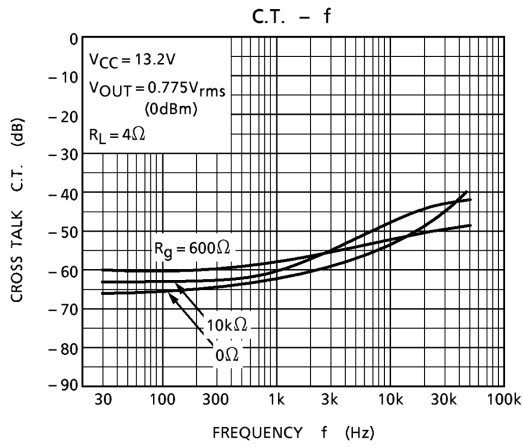
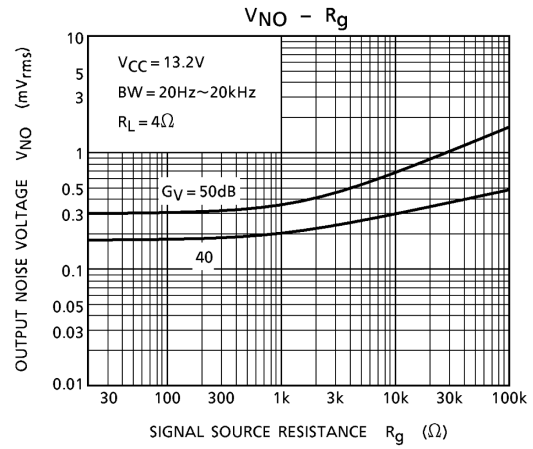
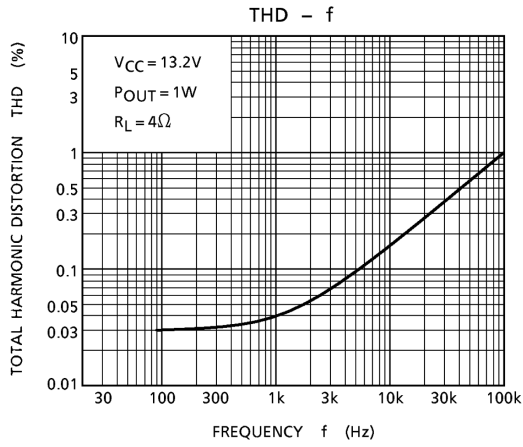

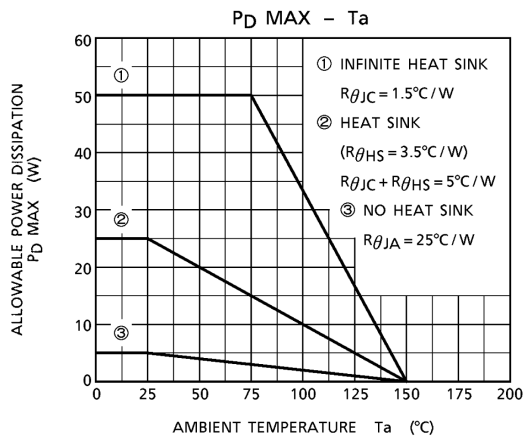
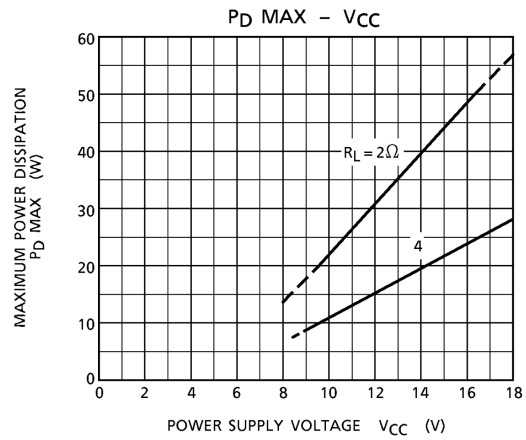
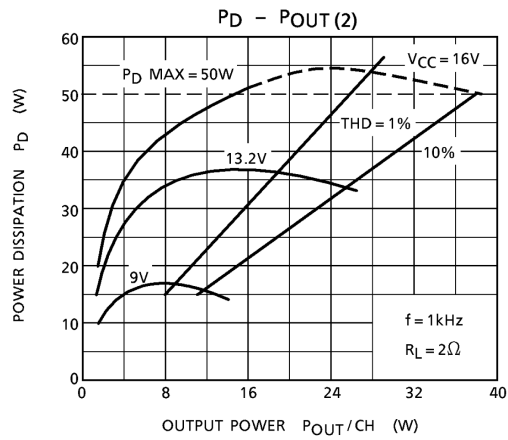
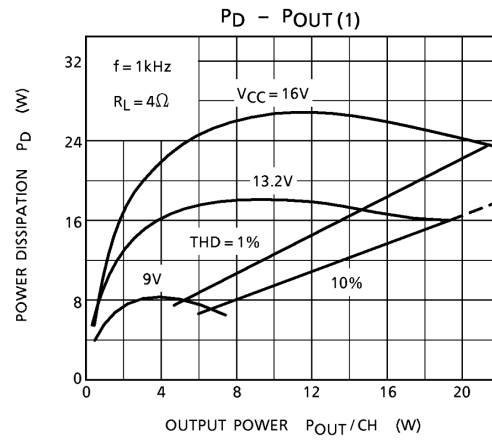
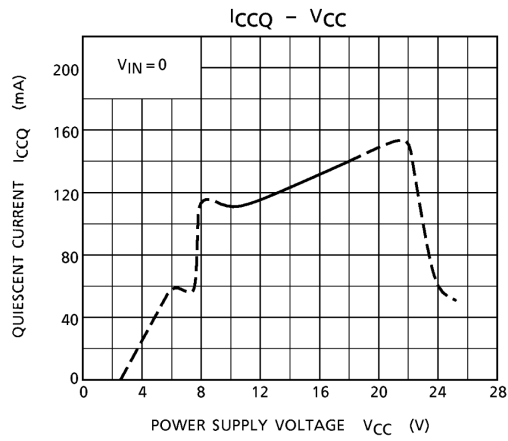

Package Dimensions

HZIP17-P-2.00

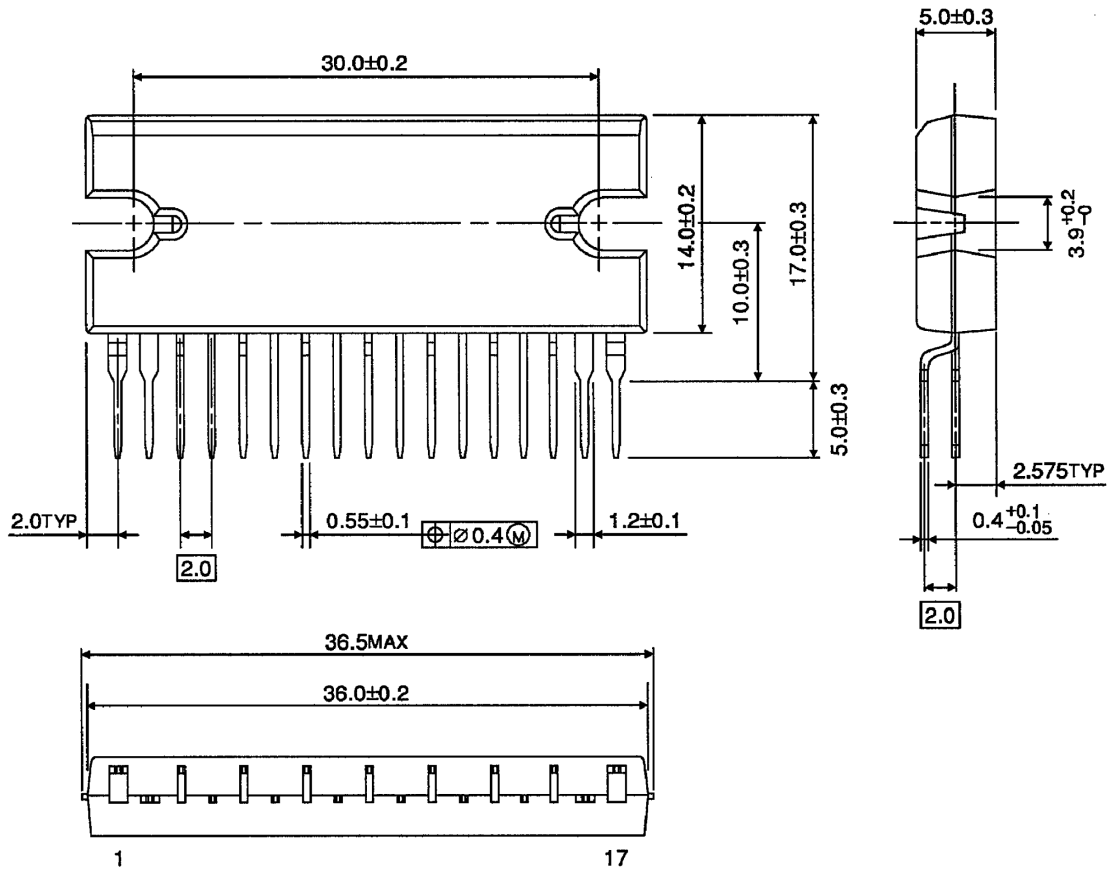

Weight: 9.8g (typ.)

About solderability, following conditions were confirmed

- Solderability
 - (1) Use of Sn-63Pb solder Bath
 - solder bath temperature = 230°C
 - dipping time = 5 seconds
 - the number of times = once
 - use of R-type flux
 - (2) Use of Sn-3.0Ag-0.5Cu solder Bath
 - solder bath temperature = 245°C
 - dipping time = 5 seconds
 - the number of times = once
 - use of R-type flux

RESTRICTIONS ON PRODUCT USE

030619EBF

- The information contained herein is subject to change without notice.
- The information contained herein is presented only as a guide for the applications of our products. No responsibility is assumed by TOSHIBA for any infringements of patents or other rights of the third parties which may result from its use. No license is granted by implication or otherwise under any patent or patent rights of TOSHIBA or others.
- TOSHIBA is continually working to improve the quality and reliability of its products. Nevertheless, semiconductor devices in general can malfunction or fail due to their inherent electrical sensitivity and vulnerability to physical stress. It is the responsibility of the buyer, when utilizing TOSHIBA products, to comply with the standards of safety in making a safe design for the entire system, and to avoid situations in which a malfunction or failure of such TOSHIBA products could cause loss of human life, bodily injury or damage to property.
In developing your designs, please ensure that TOSHIBA products are used within specified operating ranges as set forth in the most recent TOSHIBA products specifications. Also, please keep in mind the precautions and conditions set forth in the "Handling Guide for Semiconductor Devices," or "TOSHIBA Semiconductor Reliability Handbook" etc..
- The TOSHIBA products listed in this document are intended for usage in general electronics applications (computer, personal equipment, office equipment, measuring equipment, industrial robotics, domestic appliances, etc.). These TOSHIBA products are neither intended nor warranted for usage in equipment that requires extraordinarily high quality and/or reliability or a malfunction or failure of which may cause loss of human life or bodily injury ("Unintended Usage"). Unintended Usage include atomic energy control instruments, airplane or spaceship instruments, transportation instruments, traffic signal instruments, combustion control instruments, medical instruments, all types of safety devices, etc.. Unintended Usage of TOSHIBA products listed in this document shall be made at the customer's own risk.
- The products described in this document are subject to the foreign exchange and foreign trade laws.
- TOSHIBA products should not be embedded to the downstream products which are prohibited to be produced and sold, under any law and regulations.
- This product generates heat during normal operation. However, substandard performance or malfunction may cause the product and its peripherals to reach abnormally high temperatures.
The product is often the final stage (the external output stage) of a circuit. Substandard performance or malfunction of the destination device to which the circuit supplies output may cause damage to the circuit or to the product.