

CS4122

Triple Air-Core Gauge Driver with Serial Input Bus

The CS4122 converts digital data from a microprocessor to complementary DC outputs and drives air-core meter movements for vehicle instrument panels. It is optimized for one 360° gauge and two 112° gauges. The digital data controls the voltage applied to the quadrature coils of the meters with a 0.35° resolution for the major (360°) gauge and 0.44° resolution for the minor (112°) gauges. The accuracy is ±0.75° for the major and ±1.00° for the minors. The interface from the microcontroller is by a SPI compatible serial connection using up to a 2.0 MHz shift clock rate.

The digital code is shifted into the appropriate DAC and multiplexer. These two blocks provide a tangential conversion function to change the digital data into the appropriate DC coil voltage. The major gauge driver can position a pointer anywhere within a 360° circle while the minor gauge drivers are limited to an arc of 112.2°.

The output buffers are capable of supplying up to 70 mA per coil and are protected against output short circuit conditions. A thermal protection circuit limits the junction temperature to approximately 160°C.

A fault output lead goes low when any of the outputs are shorted or the device is in a thermal shutdown state. This ASIC is designed on POWERSENSE™ 3.0.

Features

- Serial Input Bus
- 2.0 MHz Operating Frequency
- Independently Addressable Gauges
- Tangential Drive Algorithm
- 70 mA Drive Circuits
- 0.75° Major Accuracy
- Power-On-Reset
- Protection Features
 - Short Circuit
 - Overtemperature
- Internally Fused Leads in SO-24L Package



ON Semiconductor™

<http://onsemi.com>

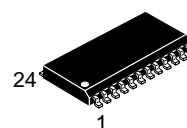

SO-24L
DWF SUFFIX
CASE 751E

MARKING DIAGRAM

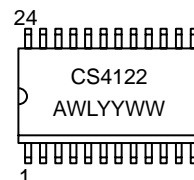

A = Assembly Location
WL, L = Wafer Lot
YY, Y = Year
WW, W = Work Week

PIN CONNECTIONS

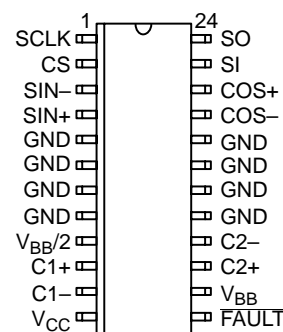

ORDERING INFORMATION

Device	Package	Shipping
CS4122XDWF24	SO-24L	31 Units/Rail
CS4122XDWFR24	SO-24L	1000 Tape & Reel

CS4122

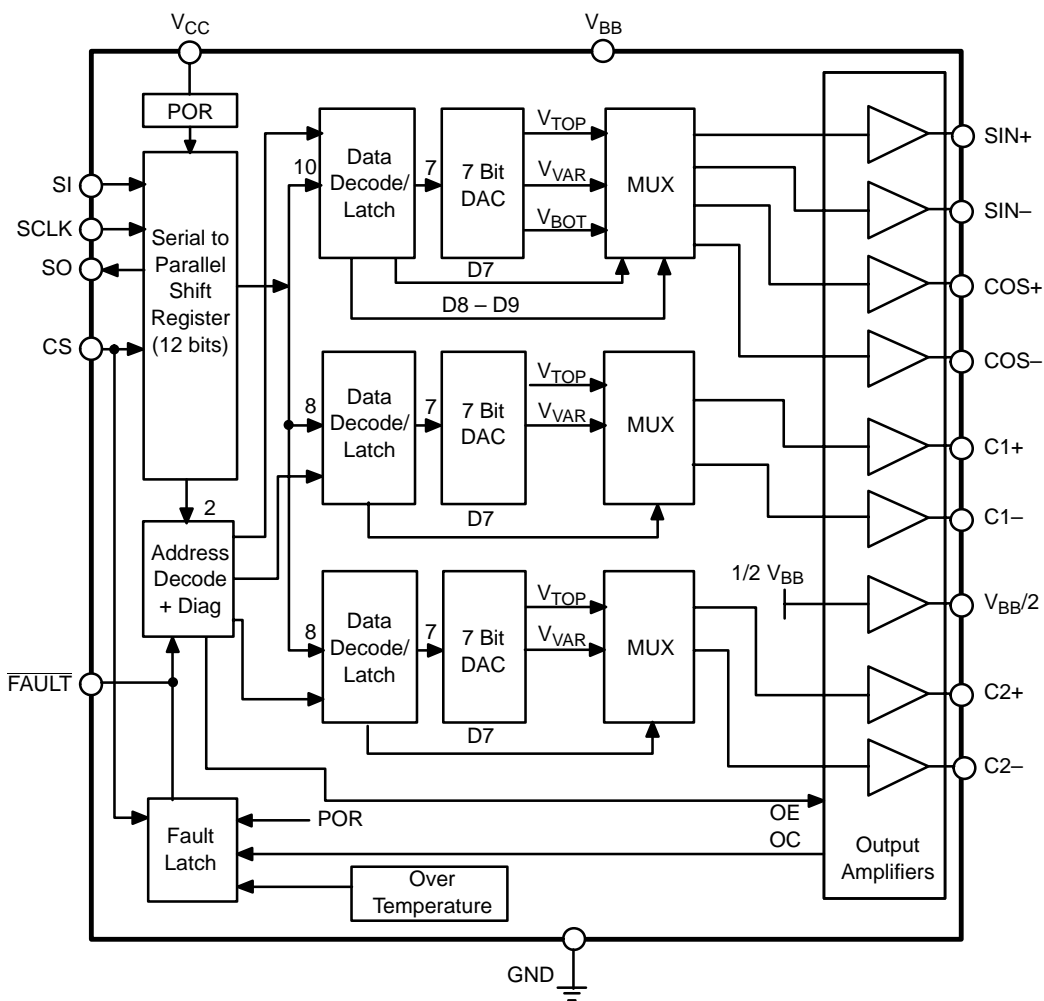

Figure 1. Block Diagram

ABSOLUTE MAXIMUM RATINGS*

Rating		Value	Unit
Supply Voltage	V _{BB}	-1.0 to 16.5	V
	V _{CC}	-1.0 to 6.0	V
Digital Inputs		-1.0 to 6.0	V
Steady State Output Current		±100	mA
Forced Injection Current (Inputs and Supply)		±10	mA
Operating Junction Temperature (T _J)		150	°C
Storage Temperature Range (T _{STG})		-65 to 150	°C
Θ _{JA} (Thermal Resistance Junction to Ambient)		55	°C/W
Θ _{JC} (Thermal Resistance Junction to Case)		9	°C/W
Lead Temperature Soldering:	Reflow: (SMD styles only) (Note 1.)	230 peak	°C

1. 60 second maximum above 183°C.

*The maximum package power dissipation must be observed.

CS4122

ELECTRICAL CHARACTERISTICS ($-40^{\circ}\text{C} \leq T_A \leq 105^{\circ}\text{C}$, $7.5\text{ V} \leq V_{\text{BB}} \leq 14\text{ V}$, $4.5\text{ V} \leq V_{\text{CC}} \leq 5.5\text{ V}$;
unless otherwise specified.)

Characteristic	Test Conditions	Min	Typ	Max	Unit
----------------	-----------------	-----	-----	-----	------

Supply Voltages and Currents

Analog Supply Current	$V_{\text{BB}} = 14\text{ V}$, no coil loads, $R_{\text{COS}}, R_{\text{SIN}} = R_{\text{L(MIN)}}$ Major @ 45° (code = 080 ₁₆), Both Minors @ 0° (codes = 00 ₁₆)	–	–	25	mA
	Major @ 0° (code = 000 ₁₆), Both Minors @ 56° (codes = 80 ₁₆)	–	–	340	mA
		–	–	100	mA
Logic Supply Current	$V_{\text{CC}} = 5.5\text{ V}$ SCLK = 2.0 MHz SCLK = 0 MHz, $V_{\text{BB}} = 0\text{ V}$	–	–	2.0	mA
		–	–	1.5	mA

Digital Inputs and Outputs

Output High Voltage	$SO = I_{\text{OUT(HIGH)}} = 0.8\text{ mA}$	$V_{\text{CC}} - 0.8$	–	–	V
Output Low Voltage	$SO = I_{\text{OUT(LOW)}} = 1.5\text{ mA}$	–	–	0.4	V
	FAULT, $I_{\text{OUT(LOW)}} = 2.8\text{ mA}$	–	–	0.8	V
Output High Current	FAULT, $V_{\text{CC}} = 5.0\text{ V}$, $V_{\text{OUT(HIGH)}} = V_{\text{CC}}$	–	–	25	μA
Input High Voltage	CS, SCLK, SI	$0.7 \times V_{\text{CC}}$	–	–	V
Input Low Voltage	CS, SCLK, SI	–	–	$0.3 \times V_{\text{CC}}$	V
Input High Current	CS, SCLK, SI, $V_{\text{IN}} = 0.7 \times V_{\text{CC}}$	–	–	1.0	μA
Input Low Current	CS, SCLK, SI, $V_{\text{IN}} = 0.3 \times V_{\text{CC}}$	–	–	1.0	μA

Analog Outputs

Output Function Accuracy	Major Accuracy	–	–	± 0.75	deg
	Minor Accuracy	–	–	± 1.00	deg
Output Shutdown Current, Source and Sink	$V_{\text{BB}} = \text{Max}$	70	–	–	mA
	$V_{\text{BB}} = \text{Min}$	43	–	–	mA
Major Coil Drive Output Voltage	–	–	$0.748 \times V_{\text{BB}}$	–	V
Minor Coil Drive Output Voltage	–	–	$0.744 \times V_{\text{BB}}$	–	V
$V_{\text{BB}}/2$	$I_{\text{DR}(V_{\text{BB}}/2)} = \pm 50\text{ mA}$	$(0.5 \times V_{\text{BB}}) - 0.1$	–	$(0.5 \times V_{\text{BB}}) + 0.1$	V
Minimum Load Resistance	$T_A = 105^{\circ}\text{C}$	229	–	–	Ω
	$T_A = 25^{\circ}\text{C}$	171	–	–	Ω
	$T_A = -40^{\circ}\text{C}$	150	–	–	Ω
SCLK Frequency	–	–	–	2.0	MHz
SCLK High Time	–	175	–	–	ns
SCLK Low Time	–	175	–	–	ns
SO Rise Time	0.75 V to $V_{\text{CC}} - 1.2\text{ V}$; $C_L = 90\text{ pF}$	–	–	100	ns
SO Fall Time	$V_{\text{CC}} - 1.2\text{ V}$ to 0.75 V; $C_L = 90\text{ pF}$	–	–	100	ns
SO Delay Time	$C_L = 90\text{ pF}$	–	–	150	ns
SI Setup Time	–	75	–	–	ns
SI Hold Time	–	75	–	–	ns
CS Setup Time	–	0	–	–	ns
CS Hold Time	–	75	–	–	ns

CS4122

PIN FUNCTION DESCRIPTION

PACKAGE PIN #	PIN SYMBOL	FUNCTION
SO-24L		
1	SCLK	Serial clock for shifting in/out of data. Rising edge shifts data on SI into the shift register and the falling edge changes the data on SO.
2	CS	When High, allows data at SI to be shifted into the internal shift register with the rising edge of SCLK. The falling edge transfers the shift register contents into the DAC and multiplexer to update the output buffers. The falling edge also re-enables the output drivers if they have been disabled by a fault.
3	SIN-	Negative output for SINE coil.
4	SIN+	Positive output for SINE coil.
5, 6, 7, 8, 17, 18, 19, 20	GND	Ground for V_{BB} and V_{CC} supplies. In the power SOIC package they aid in removing internally generated heat from the package and as such should be soldered to as large a PCB area as possible.
9	$V_{BB}/2$	Set to $1/2 V_{BB}$ for biasing the two externally driven minor coils.
10	C1+	Positive output for the #1 minor coil.
11	C1-	Negative output for the #1 minor coil.
12	V_{CC}	5.0 V logic supply. The internal registers and latches are reset by a POR generated by the rising edge of the voltage on this lead.
13	FAULT	Reflects the state of the output buffers. A logic low on this lead indicates that an output is shorted or the device is in thermal shutdown.
14	V_{BB}	Analog supply. Nominally 12 V.
15	C2+	Positive output for the #2 minor coil.
16	C2-	Negative output for the #2 minor coil.
21	COS-	Negative output for COSINE coil.
22	COS+	Positive output for COSINE coil.
23	SI	Serial data input. Data present at the rising edge of the clock signal is shifted into the internal shift register.
24	SO	Serial data output. Existing 12 bit data is shifted out when new data is shifted in. Allows cascading of multiple devices on common serial port.

APPLICATIONS INFORMATION

THEORY OF OPERATION

The CS4122 is for interfacing between a microcontroller or microprocessor and air-core meters commonly used in automotive vehicles for speedometers, tachometers and auxiliary gauges. These meters are built using 2 coils placed at 90° orientation to each other. A magnetized disc floats in the middle of the coils and responds to the magnetic field generated by each coil. The disc has a shaft attached to it that protrudes out of the assembly. A pointer indicator is attached to this shaft and in conjunction with a separate printed scale displays the vehicle's speed, engine's speed or other information such as fuel quantity or battery voltage.

The disc (and pointer) respond to the vector sum of the voltages applied to the coils. Ideally, this relationship follows a sine/cosine equation. Since this is a transcendental and non-linear function, devices of this type use an approximation for this relationship. The CS4122 uses a tangential algorithm as shown in Figure 2 for the major (360°) gauge. Only one output varies in any 45° range.

Note: The actual slopes are segmented but are shown here as straight lines for simplicity.

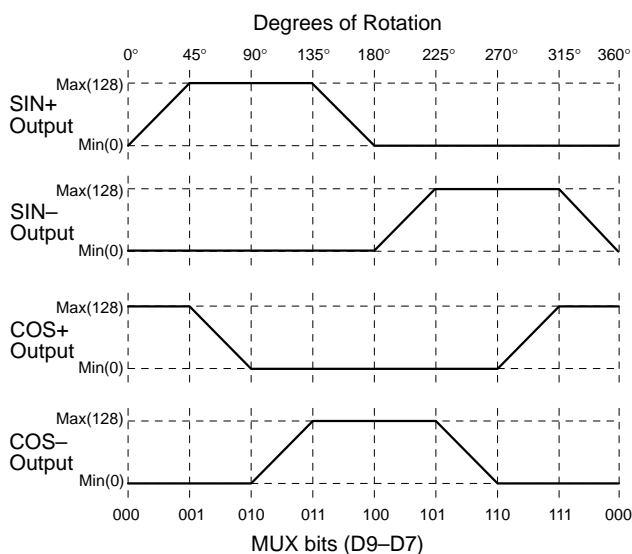

Figure 2. Major Gauge Outputs

Quadrant I

$$\theta = \tan^{-1} \left[\frac{(V_{SIN+}) - (V_{SIN-})}{(V_{COS+}) - (V_{COS-})} \right]$$

For $\theta = 0.176^\circ$ to 44.824° :

$$V_{SIN} = \tan \theta \times 0.748 \times V_{BB}$$

$$V_{COS} = 0.748 \times V_{BB}$$

For $\theta = 45.176^\circ$ to 89.824° :

$$V_{SIN} = 0.748 \times V_{BB}$$

$$V_{COS} = \tan(90^\circ - \theta) \times 0.748 \times V_{BB}$$

Quadrant II

$$\theta = 180^\circ - \tan^{-1} \left[\frac{(V_{SIN+}) - (V_{SIN-})}{(V_{COS+}) - (V_{COS-})} \right]$$

For $\theta = 90.176^\circ$ to 134.824° :

$$V_{SIN} = 0.748 \times V_{BB}$$

$$V_{COS} = -\tan(\theta - 90^\circ) \times 0.748 \times V_{BB}$$

For $\theta = 135.176^\circ$ to 179.824° :

$$V_{SIN} = \tan(180^\circ - \theta) \times 0.748 \times V_{BB}$$

$$V_{COS} = -0.748 \times V_{BB}$$

Quadrant III

$$\theta = 180^\circ + \tan^{-1} \left[\frac{(V_{SIN+}) - (V_{SIN-})}{(V_{COS+}) - (V_{COS-})} \right]$$

For $\theta = 180.176^\circ$ to 224.824° :

$$V_{SIN} = -\tan(\theta - 180^\circ) \times 0.748 \times V_{BB}$$

$$V_{COS} = -0.748 \times V_{BB}$$

For $\theta = 225.176^\circ$ to 269.824° :

$$V_{SIN} = -0.748 \times V_{BB}$$

$$V_{COS} = -\tan(270^\circ - \theta) \times 0.748 \times V_{BB}$$

Quadrant IV

$$\theta = 360^\circ - \tan^{-1} \left[\frac{(V_{SIN+}) - (V_{SIN-})}{(V_{COS+}) - (V_{COS-})} \right]$$

For $\theta = 270.176^\circ$ to 314.824° :

$$V_{SIN} = -0.748 \times V_{BB}$$

$$V_{COS} = \tan(\theta - 270^\circ) \times 0.748 \times V_{BB}$$

For $\theta = 315.176^\circ$ to 359.824° :

$$V_{SIN} = -\tan(360^\circ - \theta) \times 0.748 \times V_{BB}$$

$$V_{COS} = 0.748 \times V_{BB}$$

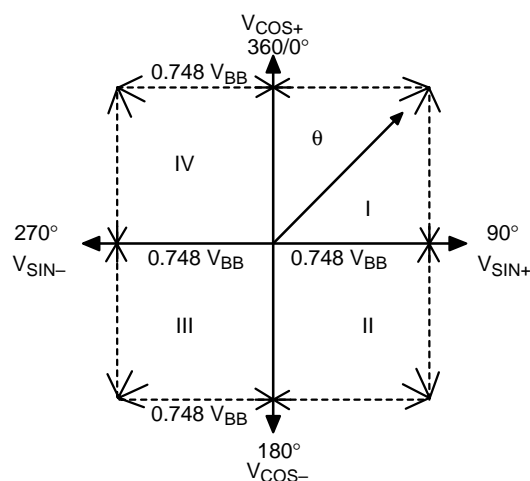

Figure 3. Major Gauge Response

The minor gauge coil outputs differ in that only one of the coils in each movement is driven by the IC. The other is driven directly by the analog supply voltage, specifically one-half of this voltage. The common output assures that this is true. By varying the voltage across the other coil to a greater voltage, the pointer can be deflected more than 45° to each side of the externally driven coil. This relationship is shown in Figure 4.

Note: There are actually 8 segments, but only 3 are shown here for simplicity.

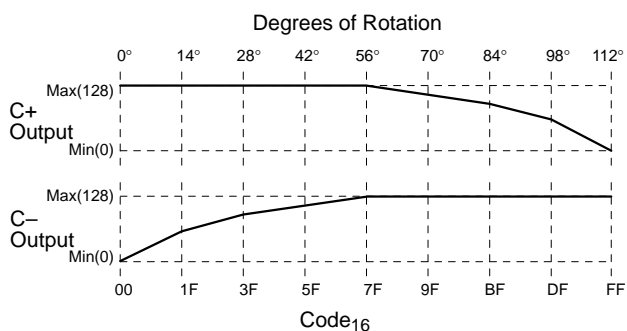

Figure 4. Minor Gauge Outputs

Quadrant I, II

$$\theta = 56.1^\circ - \tan^{-1} \left[\frac{(V_{C+}) - (V_{C-})}{V_{BB} - V(V_{BB}/2)} \right]$$

$$V_{COIL} = V(V_{BB}/2) \times \tan(56.1^\circ - \theta)$$

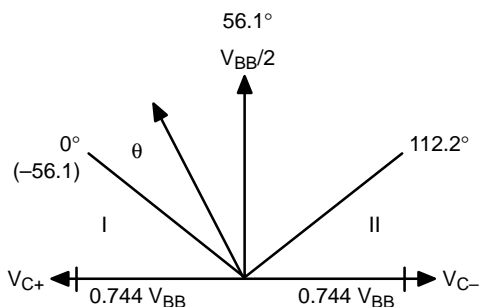

Figure 5. Minor Gauge Outputs

To drive a gauge’s pointer to a particular angle, the microcontroller sends a 12 bit digital word to the CS4122. These 12 bits are divided as shown in Figure 6. However, from a software programmer’s viewpoint, a 360° circle is divided into 1024 equal parts of .35° each and a 112.2° arc is divided into 256 parts of .44° each. Table 1 shows the data associated with the 45° divisions of the 360° driver. Table 2 shows the data for the center and end points of the 112.2° drivers. Setting the address to “11” disables all outputs.

	MSB						LSB					
	D11	D10	D9	D8	D7	D6	D5	D4	D3	D2	D1	D0
Major Gauge (360°)	Gauge Address = “00”			D9 – D7 select which octant			Divides a 45° octant into 128 equal parts to achieve a 0.35° resolution Code 0 – 127 ₁₀					
Minor Gauge #1	Gauge Address = “01”			Set to “00”			Deflection angle 0 – 112.2°, to achieve a 0.44° resolution Code 0 – 255 ₁₀					
Minor Gauge #2	Gauge Address = “10”			Set to “00”			Deflection angle 0 – 112.2°, to achieve a 0.44° resolution Code 0 – 255 ₁₀					
All Gauges Disabled	Gauge Address = “11”			All Outputs Disabled; D9 – D0 = “Don’t Care”								

Figure 6. Definition of Serial Word

Table 1. Nominal Output for Major Gauge (V_{BB} = 14 V)

Input Code (Decimal)	Ideal Degrees	Nominal Degrees	V _{SIN} (V)	V _{COS} (V)
0	0	0.176	0.032	10.472
128	45	45.176	10.472	10.412
256	90	90.176	10.472	-0.032
384	135	135.176	10.412	-10.472
512	180	180.176	-0.032	-10.472
640	225	225.176	-10.472	-10.412
768	270	270.176	-10.472	0.032
896	315	315.176	-10.476	10.412
1023	359.65	359.826	-0.032	10.472

Table 2. Nominal Output for Minor Gauges (V_{BB} = 14 V)

Input Code (Decimal)	Scale Degrees	Degrees from Center	V _{COIL}
0	0	-56.1	10.417
127	55.88	-0.22	0.027
128	56.32	0.22	-0.027
255	112.2	56.1	-10.417

The 12 bits are shifted into the device’s shift register MSB first using a SPI compatible scheme. This method is shown in Figures 6 and 7. The first 2 bits select the output driver for which the data is intended. The CS must be high and remain high for SCLK to be enabled. Data on SI is shifted in on the

rising edge of the synchronous clock signal. Data in the shift register is shifted to SO on the falling edge of SCLK. This arrangement allows the cascading of devices. SO is always enabled. Data shifts through without affecting the outputs until CS is brought low. At this time, the internal DAC is updated and the outputs change accordingly.

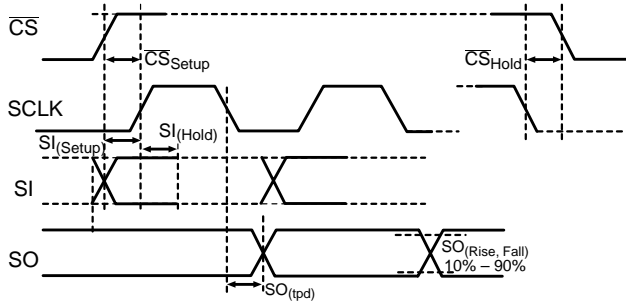

Figure 7. Serial Data Timing Diagram

The DAC for the major gauge driver outputs 128 discrete levels selected by bits D6 – D0. These bits are XOR'd with D7 to invert them when choosing the 2nd half of each quadrant (each odd octant). This reduces the number of

resistors and switches required. The MUX chooses which signals to send to the output amplifiers based upon D9 – D7. There are three choices for each amplifier: high, low or the DAC output.

The DAC's for the minor gauge drivers similarly output 128 discrete levels selected by bits D6 – D0. These bits are also XOR'd with D7 to invert them when choosing the 2nd half of the output range. The MUX chooses which signals to send to the output amplifiers based upon D7. There are two choices for each amplifier; high or the DAC output. Bits D8 and D9 are not used, but should be set to "00" to ensure that the minor gauge outputs are enabled.

The output buffers are unity gain amplifiers. Each of the 8 outputs is designed to swing close to the supply rails to maximize the voltage across the coils to produce maximum torque. Additionally, this lowers the power dissipation. The current for each output is also monitored. If any of the major gauge outputs exceed the maximum value, all of the major outputs are disabled. If any of the minor gauge outputs exceed the maximum value, all of the minor outputs are disabled. The falling edge of the CS re-enables the outputs with the fault condition but they remain on only if the overcurrent situation has been eliminated.

CS4122

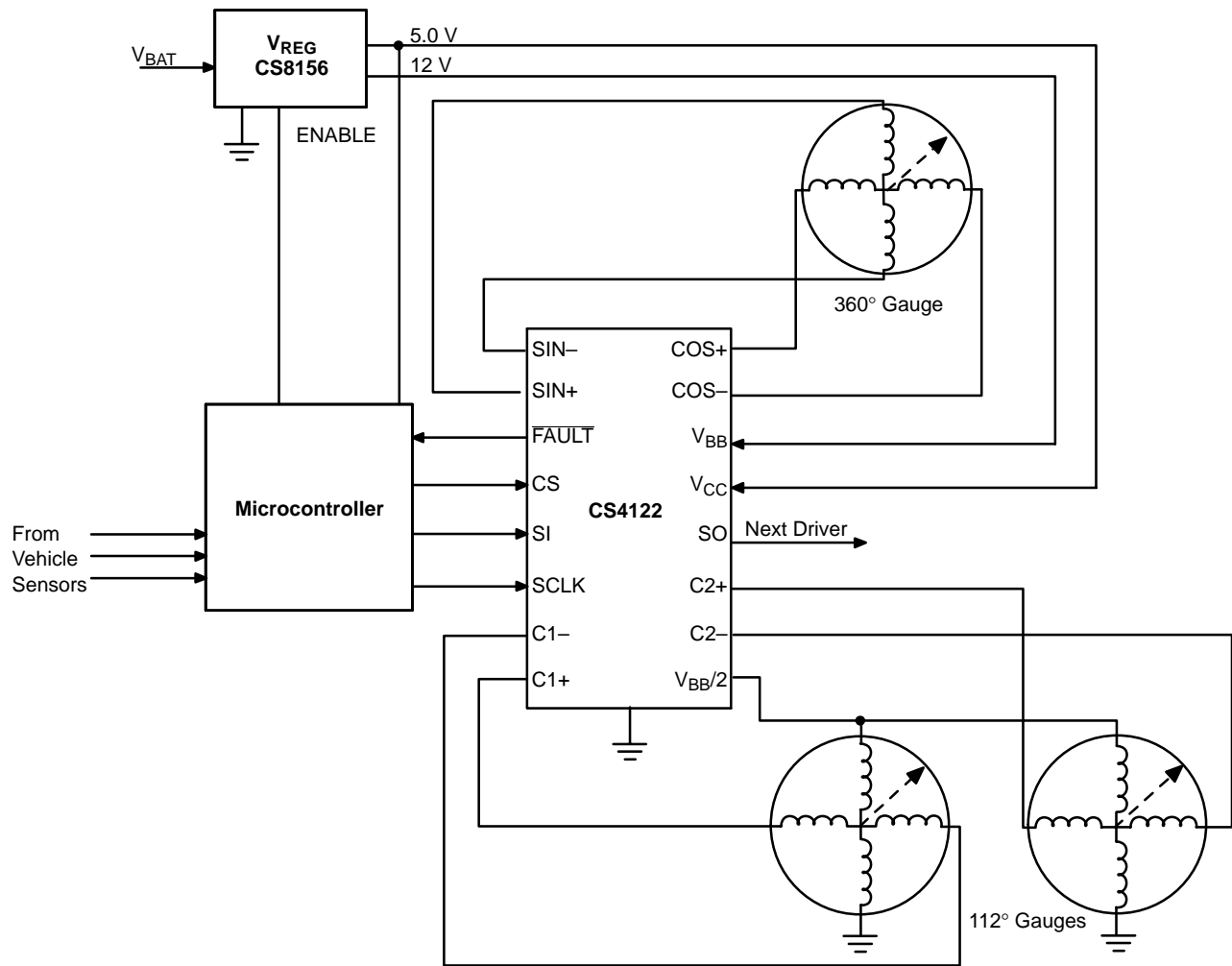
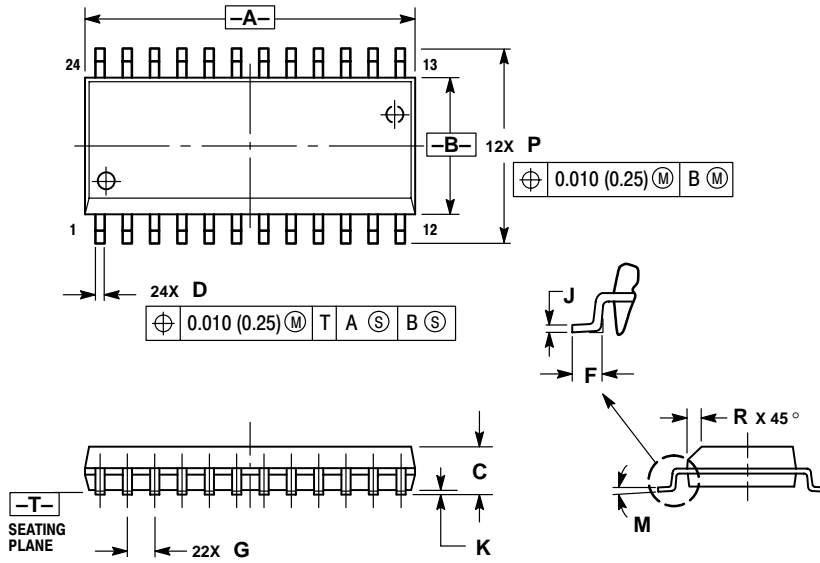

Figure 8. Application Diagram

CS4122

PACKAGE DIMENSIONS

SO-24L
DWF SUFFIX
CASE 751E-04
ISSUE E



- NOTES:
1. DIMENSIONING AND TOLERANCING PER ANSI Y14.5M, 1982.
 2. CONTROLLING DIMENSION: MILLIMETER.
 3. DIMENSIONS A AND B DO NOT INCLUDE MOLD PROTRUSION.
 4. MAXIMUM MOLD PROTRUSION 0.15 (0.006) PER SIDE.
 5. DIMENSION D DOES NOT INCLUDE DAMBAR PROTRUSION. ALLOWABLE DAMBAR PROTRUSION SHALL BE 0.13 (0.005) TOTAL IN EXCESS OF D DIMENSION AT MAXIMUM MATERIAL CONDITION.

DIM	MILLIMETERS		INCHES	
	MIN	MAX	MIN	MAX
A	15.25	15.54	0.601	0.612
B	7.40	7.60	0.292	0.299
C	2.35	2.65	0.093	0.104
D	0.35	0.49	0.014	0.019
F	0.41	0.90	0.016	0.035
G	1.27 BSC		0.050 BSC	
J	0.23	0.32	0.009	0.013
K	0.13	0.29	0.005	0.011
M	0°	8°	0°	8°
P	10.05	10.55	0.395	0.415
R	0.25	0.75	0.010	0.029

PACKAGE THERMAL DATA

Parameter		SO-24L	Unit
R _{θJC}	Typical	9	°C/W
R _{θJA}	Typical	55	°C/W

Notes

Notes

POWERSENSE is a trademark of Semiconductor Components Industries, LLC (SCILLC).

ON Semiconductor and  are trademarks of Semiconductor Components Industries, LLC (SCILLC). SCILLC reserves the right to make changes without further notice to any products herein. SCILLC makes no warranty, representation or guarantee regarding the suitability of its products for any particular purpose, nor does SCILLC assume any liability arising out of the application or use of any product or circuit, and specifically disclaims any and all liability, including without limitation special, consequential or incidental damages. "Typical" parameters which may be provided in SCILLC data sheets and/or specifications can and do vary in different applications and actual performance may vary over time. All operating parameters, including "Typicals" must be validated for each customer application by customer's technical experts. SCILLC does not convey any license under its patent rights nor the rights of others. SCILLC products are not designed, intended, or authorized for use as components in systems intended for surgical implant into the body, or other applications intended to support or sustain life, or for any other application in which the failure of the SCILLC product could create a situation where personal injury or death may occur. Should Buyer purchase or use SCILLC products for any such unintended or unauthorized application, Buyer shall indemnify and hold SCILLC and its officers, employees, subsidiaries, affiliates, and distributors harmless against all claims, costs, damages, and expenses, and reasonable attorney fees arising out of, directly or indirectly, any claim of personal injury or death associated with such unintended or unauthorized use, even if such claim alleges that SCILLC was negligent regarding the design or manufacture of the part. SCILLC is an Equal Opportunity/Affirmative Action Employer.

PUBLICATION ORDERING INFORMATION

NORTH AMERICA Literature Fulfillment:

Literature Distribution Center for ON Semiconductor
P.O. Box 5163, Denver, Colorado 80217 USA
Phone: 303-675-2175 or 800-344-3860 Toll Free USA/Canada
Fax: 303-675-2176 or 800-344-3867 Toll Free USA/Canada
Email: ONlit@hibbertco.com
Fax Response Line: 303-675-2167 or 800-344-3810 Toll Free USA/Canada

N. American Technical Support: 800-282-9855 Toll Free USA/Canada

EUROPE: LDC for ON Semiconductor – European Support

German Phone: (+1) 303-308-7140 (Mon-Fri 2:30pm to 7:00pm CET)
Email: ONlit-german@hibbertco.com
French Phone: (+1) 303-308-7141 (Mon-Fri 2:00pm to 7:00pm CET)
Email: ONlit-french@hibbertco.com
English Phone: (+1) 303-308-7142 (Mon-Fri 12:00pm to 5:00pm GMT)
Email: ONlit@hibbertco.com

EUROPEAN TOLL-FREE ACCESS*: 00-800-4422-3781

*Available from Germany, France, Italy, UK, Ireland

CENTRAL/SOUTH AMERICA:

Spanish Phone: 303-308-7143 (Mon-Fri 8:00am to 5:00pm MST)
Email: ONlit-spanish@hibbertco.com

ASIA/PACIFIC: LDC for ON Semiconductor – Asia Support

Phone: 303-675-2121 (Tue-Fri 9:00am to 1:00pm, Hong Kong Time)
Toll Free from Hong Kong & Singapore:
001-800-4422-3781
Email: ONlit-asia@hibbertco.com

JAPAN: ON Semiconductor, Japan Customer Focus Center

4-32-1 Nishi-Gotanda, Shinagawa-ku, Tokyo, Japan 141-0031
Phone: 81-3-5740-2745
Email: r14525@onsemi.com

ON Semiconductor Website: <http://onsemi.com>

For additional information, please contact your local Sales Representative.